

EAACI Molecular Allergology User's Guide 2.0

Stephanie Dramburg¹ | Christiane Hilger² | Alexandra F. Santos^{3,4,5} |
 Leticia de las Vecillas⁶ | Rob C. Aalberse^{7,8} | Nathalie Acevedo⁹ | Lorenz Aglas¹⁰ |
 Friedrich Altmann¹¹ | Karla L. Arruda¹² | Riccardo Asero¹³ |
 Barbara Ballmer-Weber^{14,15} | Domingo Barber^{16,17} | Kirsten Beyer¹ |
 Tilo Biedermann¹⁸ | Maria Beatrice Bilo^{19,20} | Simon Blank²¹ |
 Philipp P. Bosshard¹⁵ | Heimo Breiteneder²² | Helen A. Brough^{3,5} |
 Merima Bublin²² | Dianne Campbell^{23,24} | Luis Caraballo⁹ |
 Jean Christoph Caubet²⁵ | Giorgio Celi²⁶ | Martin D. Chapman²⁷ |
 Maksymilian Chruszcz²⁸ | Adnan Custovic²⁹ | Rebecca Czolk^{2,30} |
 Janet Davies^{31,32} | Nikolaos Douladiris³³ | Bernadette Eberlein¹⁸ |
 Motohiro Ebisawa³⁴ | Anna Ehlers^{35,36,60} | Philippe Eigenmann²⁵ |
 Gabriele Gadermaier¹⁰ | Mattia Giovannini³⁷ | Francisca Gomez^{38,39} |
 Rebecca Grohman⁴⁰ | Carole Guillet^{15,41} | Christine Hafner⁴² |
 Robert G. Hamilton⁴³ | Michael Hauser¹⁰ | Thomas Hawranek⁴⁴ |
 Hans Jürgen Hoffmann^{45,46} | Thomas Holzhauser⁴⁷ | Tomona Iizuka⁴⁸ |
 Alain Jacquet⁴⁹ | Thilo Jakob⁵⁰ | Bente Janssen-Weets^{2,51} | Uta Jappe^{52,53,54} |
 Marek Jutel⁵⁵ | Tanja Kalic^{22,42} | Sandip Kamath^{56,57} | Sabine Kespohl⁵⁸ |
 Jörg Kleine-Tebbe⁵⁹ | Edward Knol⁶⁰ | André Knulst⁶⁰ | Jon R. Konradson^{61,62} |
 Peter Korošec^{63,64} | Annette Kuehn² | Gideon Lack^{3,4,5} | Thuy-My Le^{36,60} |
 Andreas Lopata^{56,57} | Olga Luengo^{17,65} | Mika Mäkelä^{66,67} |
 Alessandro Maria Marra⁶⁸ | Clare Mills⁶⁹ | Martine Morisset⁷⁰ |
 Antonella Muraro⁷¹ | Anna Nowak-Węgrzyn^{72,73} | Roni Nugraha^{57,74} |
 Markus Ollert^{2,51} | Kati Palosuo⁷⁵ | Elide Anna Pastorello⁷⁶ |
 Sarita Ulhas Patil^{77,78} | Thomas Platts-Mills⁷⁹ | Anna Pomés²⁷ |
 Pascal Poncet^{80,81} | Ekaterina Potapova¹ | Lars K. Poulsen⁸² |
 Christian Radauer²² | Suzana Radulovic^{3,5} | Monika Raulf⁵⁸ | Pierre Rouge⁸³ |
 Joaquin Sastre⁸⁴ | Sakura Sato³⁴ | Enrico Scala⁸⁵ | Johannes M. Schmid⁴⁶ |
 Peter Schmid-Grendelmeier^{15,86} | Denise Schrama⁸⁷ | Hélène Sénéchal⁸¹ |

Stephanie Dramburg, Christiane Hilger, Alexandra Santos and Leticia de las Vecillas are shared first authors.

Paolo M. Matricardi and Karin Hoffmann-Sommergruber are shared last authors.

This is an open access article under the terms of the [Creative Commons Attribution-NonCommercial](https://creativecommons.org/licenses/by-nc/4.0/) License, which permits use, distribution and reproduction in any medium, provided the original work is properly cited and is not used for commercial purposes.

© 2023 The Authors. *Pediatric Allergy and Immunology* published by European Academy of Allergy and Clinical Immunology and John Wiley & Sons Ltd.

Claudia Traidl-Hoffmann^{86,88}  | **Marcela Valverde-Monge**⁸⁴  |
Marianne van Hage^{89,90}  | **Ronald van Ree**⁹¹  | **Kitty Verhoeckx**⁶⁰  |
Stefan Vieths⁴⁷  | **Magnus Wickman**⁹²  | **Josefina Zakzuk**⁹  | **Paolo M. Matricardi**¹  |
Karin Hoffmann-Sommergruber²² 

¹Department of Pediatric Respiratory Medicine, Immunology and Critical Care Medicine, Charité Universitätsmedizin Berlin, Berlin, Germany

²Department of Infection and Immunity, Luxembourg Institute of Health, Esch-sur-Alzette, Luxembourg

³Department of Women and Children's Health (Pediatric Allergy), School of Life Course Sciences, Faculty of Life Sciences and Medicine, King's College London, London, United Kingdom

⁴Peter Gorer Department of Immunobiology, School of Immunology and Microbial Sciences, King's College London, London, United Kingdom

⁵Children's Allergy Service, Evelina London, Guy's and St Thomas' Hospital, London, United Kingdom

⁶Department of Allergy, La Paz University Hospital, IdiPAZ, Madrid, Spain

⁷Sanquin Research, Dept Immunopathology, University of Amsterdam, Amsterdam, The Netherlands

⁸Landsteiner Laboratory, Academic Medical Centre, University of Amsterdam, Amsterdam, The Netherlands

⁹Institute for Immunological Research, University of Cartagena, Cartagena de Indias, Colombia, Colombia

¹⁰Department of Biosciences and Medical Biology, Paris Lodron University Salzburg, Salzburg, Austria

¹¹Department of Chemistry, University of Natural Resources and Life Sciences, Vienna, Austria

¹²Department of Medicine, Ribeirão Preto Medical School, University of São Paulo, Ribeirão Preto, Sao Paulo, Brasil, Brazil

¹³Ambulatorio di Allergologia, Clinica San Carlo, Paderno Dugnano, Italy

¹⁴Klinik für Dermatologie und Allergologie, Kantonsspital St. Gallen, St. Gallen, Switzerland

¹⁵Department of Dermatology, University Hospital Zurich, Zurich, Switzerland

¹⁶Institute of Applied Molecular Medicine Nemesio Diez (IMMAND), Department of Basic Medical Sciences, Facultad de Medicina, Universidad San Pablo CEU, CEU Universities, Madrid, Spain

¹⁷RETIC ARADyAL and RICORS Enfermedades Inflamatorias (REI), Madrid, Spain

¹⁸Department of Dermatology and Allergy Biederstein, School of Medicine, Technical University Munich, Munich, Germany

¹⁹Department of Clinical and Molecular Sciences, Università Politecnica delle Marche, Ancona, Italy

²⁰Allergy Unit Department of Internal Medicine, University Hospital Ospedali Riuniti di Ancona, Torrette, Italy

²¹Center of Allergy and Environment (ZAUM), Technical University of Munich, School of Medicine and Helmholtz Center Munich, German Research Center for Environmental Health, Munich, Germany

²²Department of Pathophysiology and Allergy Research, Medical University of Vienna, Vienna, Austria

²³Department of Allergy and Immunology, Children's Hospital at Westmead, Sydney Children's Hospitals Network, Sydney, New South Wales, Australia

²⁴Child and Adolescent Health, Faculty of Medicine and Health, University of Sydney, Sydney, New South Wales, Australia

²⁵Pediatric Allergy Unit, Department of Child and Adolescent, University Hospitals of Geneva, Geneva, Switzerland

²⁶Centro DH Allergologia e Immunologia Clinica ASST- MANTOVA (MN), Mantova, Italy

²⁷InBio, Charlottesville, Virginia, USA

²⁸Department of Chemistry and Biochemistry, University of South Carolina, Columbia, South Carolina, USA

²⁹National Heart and Lung Institute, Imperial College London, London, UK

³⁰Faculty of Science, Technology and Medicine, University of Luxembourg, Esch-sur-Alzette, Luxembourg

³¹Queensland University of Technology, Centre for Immunology and Infection Control, School of Biomedical Sciences, Herston, Queensland, Australia

³²Metro North Hospital and Health Service, Emergency Operations Centre, Herston, Queensland, Australia

³³Allergy Department, 2nd Paediatric Clinic, National and Kapodistrian University of Athens, Athens, Greece

³⁴Clinical Research Center for Allergy and Rheumatology, National Hospital Organization, Sagami National Hospital, Kanagawa, Japan

³⁵Chemical Biology and Drug Discovery, Utrecht University, Utrecht, The Netherlands

³⁶Center for Translational Immunology, University Medical Center Utrecht, Utrecht University, Utrecht, The Netherlands

³⁷Allergy Unit, Department of Pediatrics, Meyer Children's University Hospital, Florence, Italy

³⁸Allergy Unit IBIMA-Hospital Regional Universitario de Malaga, Malaga, Spain

³⁹Spanish Network for Allergy research RETIC ARADyAL, Malaga, Spain

⁴⁰NYU Langone Health, Department of Internal Medicine, New York, New York, USA

⁴¹Faculty of Medicine, University of Zurich, Zurich, Switzerland

⁴²Department of Dermatology, University Hospital St. Poelten, Karl Landsteiner University of Health Sciences, St. Poelten, Austria

⁴³Johns Hopkins University School of Medicine, Baltimore, Maryland, USA

⁴⁴Department of Dermatology and Allergology, Paracelsus Private Medical University, Salzburg, Austria

⁴⁵Institute for Clinical Medicine, Faculty of Health, Aarhus University, Aarhus, Denmark

- ⁴⁶Department of Respiratory Diseases and Allergy, Aarhus University Hospital, Aarhus, Denmark
- ⁴⁷Division of Allergology, Paul-Ehrlich-Institut, Langen, Germany
- ⁴⁸Laboratory of Protein Science, Graduate School of Life Science, Hokkaido University, Sapporo, Japan
- ⁴⁹Department of Biochemistry, Faculty of Medicine, Chulalongkorn University, Bangkok, Thailand
- ⁵⁰Department of Dermatology and Allergology, University Medical Center, Justus Liebig University Gießen, Gießen, Germany
- ⁵¹Odense Research Center for Anaphylaxis, University of Southern Denmark, Odense, Denmark
- ⁵²Division of Clinical and Molecular Allergology, Priority Research Area Asthma and Allergy, Research Center Borstel, Borstel, Germany
- ⁵³Leibniz Lung Center, Airway Research Center North (ARCN), Member of the German Center for Lung Research, Germany
- ⁵⁴Interdisciplinary Allergy Outpatient Clinic, Dept. of Pneumology, University of Lübeck, Lübeck, Germany
- ⁵⁵Department of Clinical Immunology, Wrocław Medical University, Wrocław, Poland
- ⁵⁶Australian Institute of Tropical Health and Medicine, James Cook University, Townsville, Queensland, Australia
- ⁵⁷Molecular Allergy Research Laboratory, College of Public Health, Medical and Veterinary Sciences, James Cook University, Townsville, Queensland, Australia
- ⁵⁸Institute for Prevention and Occupational Medicine of the German Social Accident Insurance, Institute of the Ruhr- Universität Bochum, Bochum, Germany
- ⁵⁹Allergy & Asthma Center Westend, Outpatient Clinic and Clinical Research Center, Berlin, Germany
- ⁶⁰Department of Immunology and Dermatology/ Allergology, University Medical Center Utrecht, Utrecht University, Utrecht, The Netherlands
- ⁶¹Department of Women's and Children's Health, Karolinska Institutet, Stockholm, Sweden
- ⁶²Pediatric Allergy and Pulmonology Unit at Astrid Lindgren Children's Hospital, Karolinska University Hospital, Stockholm, Sweden
- ⁶³University Clinic of Respiratory and Allergic Diseases Golnik, Golnik, Slovenia
- ⁶⁴Faculty of Pharmacy, University of Ljubljana, Ljubljana, Slovenia
- ⁶⁵Allergy Section, Internal Medicine Department, Vall d'Hebron University Hospital, Vall d'Hebron Research Institute (VHIR), Universitat Autònoma de Barcelona, Barcelona, Spain
- ⁶⁶Division of Allergy, Helsinki University Hospital and University of Helsinki, Helsinki, Finland
- ⁶⁷Pediatric Department, Skin and Allergy Hospital, Helsinki University Central Hospital, Helsinki, Finland
- ⁶⁸ASST Rhodense, Ospedale di Garbagnate Milanese, Milan, Italy
- ⁶⁹Division of Infection, Immunity and Respiratory Medicine, School of Biological Sciences, Manchester Institute of Biotechnology, The University of Manchester, Manchester, UK
- ⁷⁰Allergy Unit, Angers University Hospital, Angers, France
- ⁷¹Food Allergy Referral Centre, Department of Woman and Child Health, Padua University Hospital, Padua, Italy
- ⁷²Division of Pediatric Allergy and Immunology, NYU Grossman School of Medicine, Hassenfeld Children's Hospital, New York, New York, USA
- ⁷³Department of Pediatrics, Gastroenterology and Nutrition, Collegium Medicum, University of Warmia and Mazury, Olsztyn, Poland
- ⁷⁴Department of Aquatic Product Technology, Faculty of Fisheries and Marine Science, IPB University, Bogor, Indonesia
- ⁷⁵Department of Allergology, Helsinki University Hospital and University of Helsinki, Helsinki, Finland
- ⁷⁶Centro di Allergologia, Casa di Cura Ambrosiana Cesano Boscone, Milan, Italy
- ⁷⁷Division of Rheumatology, Allergy and Immunology, Departments of Medicine, Massachusetts General Hospital, Harvard Medical School, Boston, Massachusetts, USA
- ⁷⁸Division of Allergy and Immunology, Department of Pediatrics, Massachusetts General Hospital, Boston, Massachusetts, USA
- ⁷⁹Division of Allergy and Clinical Immunology, University of Virginia, Charlottesville, Virginia, USA
- ⁸⁰Institut Pasteur, Immunology Department, Paris, France
- ⁸¹Allergy & Environment Research Team Armand Trousseau Children Hospital, APHP, Paris, France
- ⁸²Allergy Clinic, Department of Dermatology and Allergy, Copenhagen University Hospital-Herlev and Gentofte, Copenhagen, Denmark
- ⁸³UMR 152 PharmaDev, IRD, Université Paul Sabatier, Faculté de Pharmacie, Toulouse, France
- ⁸⁴Allergy Service, Fundación Jiménez Díaz; CIBER de Enfermedades Respiratorias (CIBERES); Faculty of Medicine, Universidad Autonoma de Madrid, Madrid, Spain
- ⁸⁵Clinical and Laboratory Molecular Allergy Unit – IDI- IRCCS, Fondazione L M Monti Rome, Rome, Italy
- ⁸⁶Christine Kühne Center for Allergy Research and Education CK-CARE, Davos, Switzerland
- ⁸⁷Centre of Marine Sciences (CCMAR), Universidade do Algarve, Faro, Portugal
- ⁸⁸Department of Environmental Medicine, Faculty of Medicine, University of Augsburg, Augsburg, Germany
- ⁸⁹Department of Medicine Solna, Division of Immunology and Allergy, Karolinska Institutet, Stockholm, Sweden
- ⁹⁰Department of Clinical Immunology and Transfusion Medicine, Karolinska University Hospital, Stockholm, Sweden
- ⁹¹Department of Experimental Immunology and Department of Otorhinolaryngology, Amsterdam University Medical Centers, Academic Medical Center, University of Amsterdam, Amsterdam, The Netherlands
- ⁹²Department of Environmental Medicine, Karolinska Institutet, Stockholm, Sweden

Correspondence

Karin Hoffmann-Sommergruber,
Department of Pathophysiology and
Allergy Research, Medical University of
Vienna, Vienna, Austria.
Email: karin.hoffmann@meduniwien.ac.at

Editor: Ömer KALAYCI

Abstract

Since the discovery of immunoglobulin E (IgE) as a mediator of allergic diseases in 1967, our knowledge about the immunological mechanisms of IgE-mediated allergies has remarkably increased. In addition to understanding the immune response and clinical symptoms, allergy diagnosis and management depend strongly on the precise identification of the elicitors of the IgE-mediated allergic reaction. In the past four decades, innovations in bioscience and technology have facilitated the identification and production of well-defined, highly pure molecules for component-resolved diagnosis (CRD), allowing a personalized diagnosis and management of the allergic disease for individual patients. The first edition of the "EAACI Molecular Allergology User's Guide" (MAUG) in 2016 rapidly became a key reference for clinicians, scientists, and interested readers with a background in allergology, immunology, biology, and medicine. Nevertheless, the field of molecular allergology is moving fast, and after 6 years, a new EAACI Taskforce was established to provide an updated document. The Molecular Allergology User's Guide 2.0 summarizes state-of-the-art information on allergen molecules, their clinical relevance, and their application in diagnostic algorithms for clinical practice. It is designed for both, clinicians and scientists, guiding health care professionals through the overwhelming list of different allergen molecules available for testing. Further, it provides diagnostic algorithms on the clinical relevance of allergenic molecules and gives an overview of their biology, the basic mechanisms of test formats, and the application of tests to measure allergen exposure.

KEYWORDS

allergy, allergy diagnosis, anaphylaxis, asthma, atopic dermatitis, basophil activation test, component-resolved diagnosis, cross-reactive carbohydrates, diagnostic algorithms, food allergy, gibberellin-regulated proteins, pollen allergy, IgE, IgE cross-reactivity, lipocalins, microarray, molecular allergology, non-specific lipid transfer proteins, oleosins, pan-allergens, parvalbumins, pathogenesis-related protein family 10, precision medicine, polcalcins, profilins, seed storage proteins, serum albumins, tropomyosins

Preface from the EAACI President

Allergies are on the rise with significant burden both on affected individuals and on the societies. Despite representing a major public health issue and constant public awareness campaigns, allergic diseases are still under-recognized.

There is a need to (a) improve the care of allergic patients, (b) provide up-to-date education of healthcare professionals, (c) increase awareness of the public, and (d) raise a voice for patients. All these goals are in line with the Mission of the **European Academy of Allergy and Immunology – EAACI**. The translation of best knowledge into best practice is one of the key aims of EAACI. Atlases, Guidelines, and books published by EAACI represent a reference for physicians, scientific and health care organizations, as well as health policy makers, and are highly cited.

The Molecular Allergology User's Guide, published in 2016, was a good example of a well-received overview on new technologies that facilitated **Molecular Allergology** and took allergy diagnostics and patient care to the next level.

However, since 2016, a lot of new evidence has been accumulated, and new allergen sources and allergenic molecules have been identified. Diagnostic methods have subsequently been developed and adopted. Cohort studies were performed documenting polymolecular sensitization patterns and methods were developed to help assessing the risk of allergen exposure. With such methods, detailed studies on allergen-specific immune responses leading to an allergic reaction became feasible. Also, new findings on allergen families and their relevance for immune responses told us to challenge the previously developed diagnostic algorithms.

Therefore, EAACI identified the need for an updated version and a dedicated Task Force on "**The Molecular Allergology User's Guide 2.0**" was set by the EAACI Executive Committee in 2021.

This undertaking could not have been accomplished without dedication, commitment, and the spirit of team work in close interaction between clinicians and scientists with the support of the EAACI leadership and the EAACI Family. Within this Task Force, 100 contributors provided their expertise and data to get the work finalized.

I would like to express special thanks go to the **Editorial team**, Karin Hoffmann-Sommergruber, Christiane Hilger, Stephanie Dramburg, Alexandra Santos, Leticia de las Villas, **and all the Authors**, both the ones that were part of the first edition and the "newcomers" for the current edition. Among all contributors the support from Paolo Matricardi, who was the driving force behind the first edition and also actively engaged in the second edition, needs to be specifically mentioned.

This **Molecular Allergology User's Guide 2.0** provides state-of-the-art information on allergen molecules, their clinical relevance, and their application in diagnostic algorithms for clinical practice. It is designed for both, clinicians and scientists, guiding health care

professionals through the overwhelming list of different allergen molecules identified available for testing. Further, it provides diagnostic algorithms based on current knowledge about the clinical relevance of allergen molecules and gives an overview on the basic mechanisms of test formats, the biology of allergen molecules and the application of tests to measure allergen exposure.

It is with pride that I endorse this EAACI Publication, hoping that it will serve as the very useful resource to the whole Allergy community.

Marek Jutel

President of the European Academy of Allergy and Clinical Immunology-EAACI

Preface from Dr. Paolo Matricardi, initiator of the first EAACI Task Force leading to the production of the first edition of the "Molecular Allergology User's Guide"

In its six years (since 2016), the first edition of this book has received enormous attention from researchers, allergists, doctors, and other readers. Over 400 citations in ISI and over 700 in Google-Scholar demonstrate how urgent the need of systematic information on allergen molecules is as a basis to develop clinical and biological research and improve the diagnostics and therapy of the allergic patient in routine clinical practice. Thanks to the EAACI Molecular Allergology User's Guide, the concepts, technologies, and algorithms published years ago have been more and more integrated into clinical practice of allergists all over the world.

Nevertheless, the field of Molecular Allergology is moving fast and the first edition of the book was quickly becoming "old." New molecules have been discovered, characterized, cloned and their clinical relevance demonstrated. Under the pressure of clinical questions and readers' comments, new chapters have been added, such as the one on Cross-reactive Carbohydrate Determinants (CCDs), edible insects, and new types of cross-reactive molecules (e.g., gibberellin-regulated proteins, oleosins). In addition, the growth of the team and inclusion of new and younger authors, testifies that Molecular Allergology is "young" and future-oriented.

I welcome therefore the great effort of the new Editors of the book, who prepared this second Edition in a short "record" time. I am especially grateful to Dr. Stephanie Dramburg and Dr. Christiane Hilger, who played a central role already in the preparation of the first edition and represent the continuity of the original spirit of the editorial team for a coherent update and progression of the text.

I am also very thankful to EAACI for the continuous support and particularly to the Vice President Communications and Membership, Prof. Dr. Karin Hoffmann-Sommergruber, who not

only directed the Editorial Team of this Second Edition but also guaranteed a continuous link between the authors and the EAACI Leadership.

The seeds that over 60 experts planted, together with my co-editors Markus Ollert, Jörg Kleine-Tebbe, Hans Jürgen Hoffmann and Rudolf Valenta, in 2016, flourished and produced a beautifully

growing plant. Given the trend towards precision medicine, including "precision allergology," it is easy to predict the success of this second edition and to foresee a third edition before 2030!

Paolo Maria Matricardi - Berlin, 25 May 2022

A01 – Molecular allergology coming of age—an introduction to the second edition of the EAACI User's Guide (MAUG 2.0)

Since the discovery of immunoglobulin E (IgE) as mediator of allergic diseases in 1967,¹ our knowledge about the immunological mechanisms of IgE-mediated allergic diseases has remarkably increased. In addition to understanding the immune response and clinical symptoms, allergy diagnosis and management depend strongly on the precise identification of the elicitors of the IgE-mediated allergic reaction. Currently, 1080 molecules from different animals, fungi, and plants have been identified as allergens and are listed in the IUIS/WHO database.^{2,3}

In the past four decades, innovations in bioscience and technology have facilitated the identification and production of well-defined, highly pure molecules for component-resolved diagnosis (CRD), allowing a personalized diagnosis and management of allergic diseases for individual patients. In addition to individual molecules, chip-based test systems have evolved, enabling the simultaneous detection of specific IgE antibodies directed towards more than 100 allergenic molecules within one test run.

The identification of IgE antibodies to specific molecules can, not only improve diagnosis but also have additional applications, such as the risk assessment of sensitized individuals, monitoring of environmental exposure, and detection of specific allergens in foods. Novel allergens are constantly being described and new allergen sources, such as edible insects, for example. The role of immunoactive substances, such as ligands, can contribute to an accurate diagnosis. This ever-changing multitude of new developments and research requires updated literature and shared perspectives from experts in the Molecular Allergology field.

The First Edition of the “EAACI Molecular Allergology User's Guide” (MAUG) was launched in 2016 and rapidly became a key reference for clinicians, scientists, and interested readers with a background in allergology, immunology, biology, and medicine, more broadly. From the beginning, the content has been freely available to the community as an e-book at www.eaaci.org and as a supplement of the journal *Pediatric Allergy and Immunology*, where it quickly became one of the most cited articles.⁴ As science and knowledge keep evolving rapidly, the editors and authors of the first book agreed on the need of an updated edition. A team of five colleagues (Karin Hoffmann-Sommergruber, Christiane Hilger, Stephanie Dramburg (formerly Hofmaier), Alexandra Santos, and Leticia de las Vecillas) came together to coordinate the process and applied for an EAACI Task Force in order to secure the indispensable support of the EAACI family. This new editorial team, led by Karin Hoffmann-Sommergruber, benefited from the support from Paolo Matricardi, chair of the first task force on CRD in Allergology, both as an advisor and author of several chapters of MAUG 2.0. All authors of the first edition were invited to actively

contribute to the update and expert junior members were also included as authors for most chapters. The new edition of the “EAACI Molecular Allergology User's Guide” (MAUG 2.0) kept the basic structure of the first book with three sections focussing on: general aspects (Section A: General aspects), specific allergens/allergies (Section B: Molecular Allergology In clinical practice), and cross-reactive allergens (Section C: Cross-reactive molecules and their clinical relevance).

A: Molecular allergology: General concepts

Section A combines chapters on basic and general aspects of molecular allergology. This includes important information on allergens, their sources and superordinate families (Chapters A02, A07, A08), the role of molecular IgE testing in clinical practice (Chapter A03), methodological aspects of singleplex vs. multiplex testing (Chapter A04), and the role of allergenic molecules within *in vivo* diagnostics (Chapter A06) and basophil activation tests (Chapter 5 -A05). New chapters discuss the role of molecular allergology for allergen immunotherapy (AIT) (Chapter A09) and explain the importance of cross-reactive carbohydrate determinants (Chapter A10) for the correct interpretation of test results. A chapter sets a focus on small molecules and introduces “harmless” molecules, such as lipids, glycosylated flavonoids (and derivatives), steroids, fatty acids, or cytokinins as potential modifiers of the innate and adaptive immune response towards allergens A11. Finally, section A concludes with a comprehensive overview on molecular allergen exposure, sampling, and testing devices, and how our knowledge contributes to improved allergenic risk assessment A12.

B: Molecular allergology in clinical practice

Section B offers updated information regarding specific allergies with a clinical focus. This includes not only new information in the previously established chapters but also completely new contents, such as Chapter B09 on the role of edible insects. Within existing chapters, new insights are reported, for example, a larger section on the alpha-gal syndrome and a diagnostic algorithm for different types of meat allergy in Chapter B14, acknowledging the novelty that carbohydrate epitopes recognized by IgE antibodies are now included in the WHO/IUIS allergen nomenclature database. Another innovative chapter provides guidance on the diagnosis and management of allergies to moulds (Chapter B07), including comprehensive information on a large set of allergenic molecules. Further examples of enriched chapters are the integration of *Anisakis simplex* in Chapter B12 on fish allergy and new content on buckwheat allergy within Chapter B16 (Wheat and Buckwheat Allergy). These innovations are only a small foretaste of the new content in 22 specific chapters.

C: Cross-reactive molecules

Section C summarizes significant knowledge and latest findings on cross-reactive allergens. While updates are available for profilins (Chapter C01), PR-10 proteins (Chapter C02), non-specific lipid transfer proteins (Chapter C03) (nsLTP), serum albumins (Chapter C04), tropomyosins (Chapter C05), polcalcins (Chapter C06), lipocalins (Chapter C07), and parvalbumins (Chapter C11), new chapters have been integrated on the role of seed storage proteins (Chapter C08), gibberellin-regulated proteins (GRPs) (Chapter C09), and oleosins (Chapter C10). All in all, 45 chapters have been updated or newly written and carefully reviewed by a 100 authors from four continents—a truly international team effort. What started with a first online kick-off meeting in April 2021, evolved over several consensus and production stages including regular meetings of the editors and authors up to weekly meetings with the design team during the final phase, resulting in the launch of a comprehensive update on Molecular Allergology: MAUG 2.0 at the EAACI Annual Congress 2022 in Prague.

The editors would like to thank all the authors and contributors to MAUG 2.0 for their continuous efforts, professional contributions,

and team spirit. The editors would like to thank Marcela Ataíde and Olivia Matni for their outstanding artwork in illustrating and typesetting the book, as well as Hoang Yen Do for her excellent work on the references. Finally, the editors are grateful to the EAACI for supporting the initiative and large collaboration of almost 100 experts that allowed updating this valuable resource, the 2nd edition of the Molecular Allergology User's Guide.

We hope the readers enjoy this updated edition and that it proves useful in both clinical practice and continued research on Molecular Allergology!

We thank from the bottom of our hearts our esteemed colleague and co-author Prof. Dr. med. Jörg Kleine-Tebbe, who passed away on 5.1.2023. He contributed significantly to the creation of both editions of the EAACI Molecular Allergology User's Guide and made an extraordinary contribution to the advancement of molecular allergology.

Stephanie Dramburg, Karin Hoffmann-Sommergruber, Christiane Hilger, Alexandra F. Santos, Leticia de las Vecillas.

A02 – Allergens and the allergenic composition of source materials

Ronald van Ree, Rob C. Aalberse

Highlights

- Many different types of proteins are allergenic.
- The context of a protein may be a major determinant for its allergenicity.
- Some IgE inducers are not really allergens at all because they do not induce symptoms. This negatively impacts specificity of diagnostic tests, certainly of extract-based tests but also still of molecular tests.
- Allergen extracts are imperfect but not yet obsolete.
- Molecular sensitization profiles are potential biomarkers for disease phenotypes and progression.
- The initial response to an allergen source is possibly characterized by IgE antibodies to one or two “initiator” allergens.

Allergenic sources can vary from biologic sources with very complex composition such as pollen, house dust mites (inhalant allergy), or foods (food allergy), to single molecules such as chemicals (occupational allergy) or drugs (drug allergy). In this chapter, we will focus on the molecular composition of more complex biologic allergen sources that are implicated in causing hay fever, allergic asthma, and food allergy. Around the late sixties and early seventies of last century, first reports were published in which individual molecules were identified that were responsible for binding IgE within different allergen sources such as grass pollen,⁵ ragweed, pollen,⁶ cod fish allergen,⁷ and house dust mite.⁸ By now probably the most important allergens of the most relevant allergen sources have been identified (www.allergen.org; www.comparedatabase.org; www.allergenonline.org; www.allergome.org). Before we can discuss the allergens, we have to introduce the nomenclature of molecularly defined allergens (see [Textbox 1](#)).

1 – What is an allergen?

The broadest definition of an allergen is that it is any molecule-binding IgE antibodies.¹³ Allergens can differ in several ways (see also [Textboxes 2 and 3](#)). In this introduction, the practical consequences of four of these differences will be discussed.

2 – Sensitizing versus nonsensitizing allergens

Most, but not all, allergens are sensitizing, which is defined as the ability to induce allergen-specific IgE antibodies. Nonsensitizing allergens can only cause allergic symptoms if previous contact with a related (cross-reactive) allergen has caused sensitization. A prototypic example of a sensitizer is birch allergen Bet v 1 and

Textbox 1 Allergen nomenclature

Allergen names are based on the scientific (Latin) name of the plant or animal species from which the allergen originates.^{9,10} For example, the major allergen from birch pollen Bet v 1 is named after the scientific name of the tree *Betula verrucosa*, in which *Betula* is the genus and *verrucosa* the species. The first three letters of the genus (*Bet*) and the first letter of the species (*v*) together form the basis of the allergen name, followed by a number. In principle the number is given in order of discovery, so Bet v 1 was the first allergen from birch pollen that was discovered. Related (often cross-reactive) allergens from different species, genus, family or even order, get the same number, if still available. So, the homologue of Bet v 1 in hazel is Cor a 1 and in apple is Mal d 1 but in peanut is Ara h 8 because numbers 1–7 were already occupied by peanut allergens described earlier. Many allergens have molecular variants (isoforms). One example is Cor a 1. One isoform is mainly found in hazel pollen (Cor a 1.01), the other mainly in hazelnut (Cor a 1.04). Some isoforms are so closely related (>90% sequence identity) that they can usually be considered identical. If they need to be distinguished, two more digits are added to the name, for example, Cor a 1.0101 and Cor a 1.0102.

a cross-reactive nonsensitizer is the homologous apple allergen Mal d 1.¹⁴

3 – Airborne versus food allergens: crossing different barriers

The two most common sites of entry into the body are the mucosal surfaces of the airways in which the allergen is delivered as part of an airborne particle or aerosol droplet and the digestive tract, which includes the oral cavity where it is introduced as part of a food or drink (see [Textbox 4](#)). Also, the skin has been proposed as a route for sensitization, a hypothesis that gained significance since the discovery of filaggrin SNPs associated with the development of allergy. A prototypic example of true food allergens (primary sensitizers) is the shrimp muscle protein tropomyosin that varies in nomenclature depending on the type of shrimp (Pen a 1, Cra c 1, Met e 1, Lit v 1, etc.), or other crustaceans and molluscs, such as lobster (Hom a 1) and crayfish (Pro c 1). All these are highly cross-reactive allergens (see the official IUIS website www.allergen.org) or the Allergome website (www.allergome.org); other invertebrate allergens, such as hemocyanin and hemoglobin, are more likely to sensitize via the airways or via skin contact in an occupational setting (seafood preparation, fish food production).¹⁵ Examples of true food allergens in plants are the

Textbox 2 The long road from allergen-coding DNA to a molecule interacting with IgE on the mast cell surface

Much of our information on allergen structure comes from proteins that are produced with recombinant DNA technologies (conveniently, but scientifically incorrectly, referred to as “recombinant allergens”). Most currently available recombinant allergens are prepared based on a direct translation of their genomic information. In the real world, the allergen that is knocking at the mast cell's door is often modified. Some of the modifications are well-characterized intracellular biochemical processes known as co-translational or post-translational modifications, such as homo- and hetero-oligomerization, glycosylation, cleavage of a leader peptide, pro-peptide, and other proteolytic events, binding of metallic cofactors or organic ligands, and oxidation of proline to hydroxyproline. Others are due to more random extracellular processes often influenced by environmental conditions (humidity, UV, ozone). Examples are nitration, methionine oxidation, deamidation, and cross-linking by transglutaminases and glycation (a nonenzymatic process also known as the Maillard reaction). Upon water loss, excreted proteins attach to various substrates, both on a nano-scale (homo- and heteroaggregation) and on a microscale (attachment to fibers and dusty particles). The effect of these modifications of the structure of the allergen on allergenicity has only just started to be investigated.^{11,12}

2S albumins from legumes (e.g., Ara h 2), tree nuts (e.g., Cor a 14, Jug r 1, and Ana o 3), and seeds (e.g., Ses i 1). Although these allergens share clear structural features based on a common disulphide-bond pattern, their primary sequences are quite diverse resulting in limited [cross-reactivity](#).

4 – Initiator allergens versus secondary responding allergens

The initial response to an allergen source is possibly characterized by IgE antibodies to one or two “initiator” allergens, which tend to dominate the subsequent more complex IgE response to the allergen source in question. It is therefore an attractive hypothesis that within an allergen source some allergens are more important than others. It might be tempting to call these “major” allergens, but traditionally, an allergen is referred to as “major” if it is recognized by >50% of the patients that are sensitized to the source (see [Textbox 5](#)). Not all these “major” allergens seem to act as “initiator” allergens.

5 – Innocent versus dangerous allergens

As expected, a close association is often found between allergen exposure and allergic symptoms. However, for some sensitizers this association is very weak. Several factors may explain the position of an allergen in the allergenicity risk spectrum. In addition to all the three above-mentioned features, it is presumably relevant that some relatively innocuous sensitizers are associated with relatively high IgG/IgE ratios. A prototypic example is tetanus toxoid.²³ The allergenic risk spectrum is further discussed below.

6 – What makes an antigen an allergen?

Some, but not all, antigens that pass through our epithelial barrier trigger an IgE response (see [Textbox 6](#)). There is an ongoing debate on the features of allergenic proteins (if any) that distinguish these from the more mundane, only IgG-inducing, antigens. It has been proposed that there are few restrictions on the properties of antigens that can induce IgE antibodies.^{9,19} On the other hand, it has been argued that only a very restricted set of antigens has been found to induce IgE antibodies. This view has been promoted among others by Breiteneder et al.²⁵ Many different types of proteins are allergenic. Some features are not intrinsic to the protein itself but rather a consequence of an extrinsic feature: the context of the protein. One such extrinsic feature is the introduction of the protein in the presence of bacterial cell wall components. If a protein enters our body in the context of a bacterial infection, the innate immune response-induced cytokines (such as IL-12) usually skew the adaptive immune response towards the production of Th1-type cytokines (such as gamma-interferon) that are needed to efficiently fight the infection. Gamma-interferon prevents the production of Th2-type cytokines (particularly IL-4) that are needed for the switch to IgE. Regarding intrinsic features, the situation is not so clear-cut. While there is good evidence to support the claim that proteolytic activity may enhance the allergenicity of a protein (example: the mite allergen Der p 1), most allergens are not proteases. Some allergens have enzymatic activities that are unlikely to have an effect on human pathophysiology (example: pectinase activity of pollen allergens). Similarly, many allergens can bind small ligands, but the type of ligand varies considerably. It is not uncommon to find more than 10 different allergenic proteins in a single allergen source material (mite, pollen, peanut, shrimp, etc.). Although it seems contradictory to a basic function of the immune system, i.e., to react to non-self-proteins, it has been suggested that proteins having close homologues to human proteins are intrinsically more likely to be allergenic. Proteins of the lipocalin family are taken as an example.²⁶ It is clear that some proteins are more allergenic than others. Many factors are known to contribute to these differences, but prediction of the allergenicity (i.e., sensitization risk of a protein not cross-reactive with a known allergen) of a novel protein has thus far proven to be an

Textbox 3 The exception: some allergens are NOT proteins

Examples of nonprotein allergens are drugs such as penicillin, chlorhexidine, and other pharmacological compounds such as rocuronium. It is generally assumed that these compounds depend for their allergenicity on a strong (covalent) interaction with a carrier protein, but this has not always been demonstrated convincingly. In fact, some smaller molecules, such as chlorhexidine or polyethylene glycols (PEGs), have two or more epitopes, which will allow for cross-linking of two or more receptor-bound IgE molecules on the surface of effector cells without help from an endogenous protein. How the IgE immune response to such small molecules may develop, has been much less studied, however. One explanation might be that a metabolite is the allergologically active substance. The above-mentioned allergic drug-protein complexes are often referred to as hapten-carrier complexes. Substances other than pharmacological compounds can also act as haptens. An important category of hapten-like structures are naturally occurring chains of simple sugars, referred to as glycans. The role of glycans as IgE-reactive structure is a source of some confusion. It is generally assumed that pure glycans are unable to induce IgE antibodies. This fits with the general scheme of IgE antibody production as a process that depends on signals provided by Th2 cells, as described above. Classical MHC-II molecules are very efficient at interacting with peptides but are unable to combine with pure glycans. However, for glycans coupled to a protein carrier, the situation is different. The cell-anchored antibody on some B cells can interact with the glycan. These B cells bind the glycoprotein via the antibody-glycan interaction. Next, the B cell ingests and digests the glycoprotein and presents the peptides in its MHC-II to the T cell. The T-cell receptor interacts with the peptide-MHC-II complex on the B cell, which results in activation of the T cell. The T cell activates the B cell, which results in differentiation of the B cell to an antibody-secreting plasma cell. The important point is that the conventional Th2 cell does not recognize the glycan and yet it can induce the B cell to produce antiglycan antibodies. It is possible that glycans can be allergenic not only as glycoprotein but also as glycolipid, potentially via sources of IL-4 other than Th2 cells. This is presumably mostly relevant for immune responses to invertebrate parasites such as helminths and ticks. Two prototypic glycans with well-established IgE-binding activity are known as CCD^{16,17} and the α -Gal epitope.^{17,18} CCD (cross-reactive carbohydrate determinant) refers to a group of related glycans that are characterized by a fucose and/or a xylose that are linked in a specific way to the core of the glycan. Such glycans are produced by invertebrates and plants but not by vertebrates. Because of the widespread presence of such structures in plant foods, patients with such IgE antibodies demonstrate cross-reactivity to virtually all plant foods.¹⁹ By contrast, α -Gal (in full: the Gal- α 1-3Gal- β 1-3GlcNAc epitope) is produced by nonprimate mammals but not by humans. This structure, now commonly referred to as α -Gal, has been associated with allergy to red meat.²⁰ For yet unknown reasons, the onset of systemic (skin) symptoms observed upon consumption of meat is not immediate but delayed. Where induction of IgE antibodies against CCD is thought to be driven by pollen exposure and/or insect stings, IgE antibodies against α -Gal most likely occur in response to tick bites or helminth infections.²¹ A convenient way to distinguish peptide-based epitopes from glycan-based epitopes is the use of proteolytic enzymes or glycan-destroying chemicals (periodate). Some IgE antibodies show dual recognition towards a glycoprotein allergen: their epitope consists of a combination of part of the glycan and part of the protein.²²

unsurmountable challenge. With the advent of algorithms based on machine learning and artificial intelligence, new potentially promising avenues may open up.²⁷ The allergenicity debate will undoubtedly go on (See also the Chapter on “Basic and theoretical aspects of allergens”). From a practical point of view, it is relevant that some source materials are more allergenic than others. Illustrative examples include allergens from cooked legumes that are less allergenic than those from roasted peanuts and the lipocalins from dogs (Can f 1, Can f 2 and Can f 4 as major allergens) being less allergenic than the major allergen from cats (Fel d 1), which is a NOT a lipocalin.

7 – Clinical relevance of individual allergenic proteins

Some inhalant allergen sources contain a single dominant major allergen. The clearest example is Bet v 1 in birch pollen, which is responsible for most of the IgE binding to the allergen source. For tree pollen-allergic patients in North-western and Central Europe, Bet v

1 is of decisive clinical importance because there is no “competing” major allergen. By contrast, multiple major allergens have been described for grass pollen (i.e., group 1 (e.g., Phl p 1) and group 5 (e.g., Phl p 5) and house dust mite group 1 (e.g., Der p 1) and group 2 (e.g., Der p 2)). Currently, it is assumed that allergens from both groups are of great clinical importance. Whether they play an individual role in determining clinical phenotypes is still largely unknown. In recent studies, first indications were found that specific individual (minor) house dust mite allergens (e.g., Der p 23 and Der p 20) are associated with more severe respiratory clinical presentations such as asthma.^{28,29} It has, however, also been proposed that such associations are not necessarily explained by the molecular properties of these allergens but by a high degree of sensitization characterized by broad recognition of a multitude of major and minor allergens.³⁰ For food allergy, individual allergen molecules have more clearly been associated with both defined clinical phenotypes and the severity of allergic symptoms.³¹ There are three ways one can become allergic to a specific food, (a) by direct exposure to that food via the oral

Textbox 4 Allergens have to get into our body to sensitize and to do harm

Allergenic proteins have to be in solution in order to get into our tissues, both for the sensitization phase (the interaction reaction with a professional antigen-presenting cell, T cell and B cell) and for elicitation phase (the interaction with the IgE antibody on the surface of the mast cell or basophilic leukocyte). For inhaled allergens, the allergen will be contained in or attached to a particle (pollen grain, mould spore, mite faecal particle, a skin flake, hair, a textile fibre, or a fluid droplet) from which it is extracted upon deposition on the mucous membranes. The size of the allergen-carrying particle (typically 5–20 µm) is important, because this determines the most likely site of deposition (upper or lower airways). The allergen has to be released into the mucosal fluid to pass through the airway epithelial barrier. For this passage also a size limit exists. The diameter of a typical globular allergen molecule is some 1000 times smaller than the allergen-carrying particle (2–10 nm, in molecular mass units: 5–50 kDa). It cannot be ruled out that sensitization to inhaled allergens can also occur via the skin, in particular when the skin barrier is impaired, but also in that case, moisture is needed to solubilize the allergen, and size limits to allow it to cross the skin barrier will be similar. For food allergens the biophysical requirements for allergenicity are different in at least 2 ways. Firstly, food processing can substantially change the solubility of some proteins and in some cases also change allergenicity. In addition to the destructive effects of cooking on many allergens, another well-known example is the loss of allergenicity following the mincing of apples, due to oxidative browning of apple polyphenols. This results in denaturation of apple proteins by the tannin-like structures. Secondly, the digestive system could increase allergenicity by releasing small soluble allergenic fragments from poorly soluble conglomerates, or decrease allergenicity by more extensive fragmentation. In addition to proteases, also the low pH in the stomach and the detergent action of bile salts are important in modifying the allergenicity of ingested proteins. The resistance to proteolytic digestion is obviously of no relevance if sensitization to food occurs via the skin. The question why 2S albumins are excellent primary sensitizers while Bet v 1-like allergens are not, will most likely be explained by the abundance of the respective proteins in the environment.

route, or increasingly likely (also) via the skin, (b) by cross-reactivity between foods, and (c) by cross-reactivity between respiratory allergen sources and foods. The best-known example of the latter is fruit and tree nut allergy as comorbidity with birch pollen allergy.³²

Textbox 5 What are major and minor allergens?

Officially, a major allergen is an allergen that is recognized by IgE antibodies of >50% of patients allergic to the allergen source, and a minor by <50% of patients. This old definition has increasingly been challenged as being too simplistic.²⁴ In most cases, major allergens also bind a large fraction of the allergen source-specific IgE and are therefore (most likely) of dominant clinical importance. Similarly, minor allergens usually bind only a small fraction of the overall IgE response against the allergen source. The designation major allergen should therefore most likely take the importance of the allergen in the overall IgE response against the source into account. Most major allergens occupy the lower numbers in the nomenclature system, simply because researchers tended to identify the most dominant allergens first.

The mechanism behind this association is cross-reactivity of Bet v 1-specific IgE with structurally homologous allergens in foods like apple, peach, hazelnut and peanut (see [Textbox 7](#)). The clinical phenotype observed in such patients is characterized by mild-to-moderate symptoms restricted to the oral cavity. The explanation for the lack of (severe) systemic symptoms is thought to reside in the protease-sensitive nature of the Bet v 1-related food allergens that are readily digested in the gastrointestinal tract.³³ This characteristic also explains why sensitization to these Bet v 1-related food allergens is never seen in patients without birch pollen allergy. Apple Mal d 1 or peach Pru p 1, the Bet v 1 homologues of these fruits, are completely digested before they can directly sensitize. Moreover, Bet v 1-like allergens are not abundantly expressed in fruits, making the chance of exposure to sufficient protein in the digestive tract or on the skin even more unlikely. This does not mean that a fruit like peach cannot directly sensitize atopic subjects. Until recently, this is mainly reported for patients living around the Mediterranean Sea, but it is increasingly also observed beyond those areas.^{34,35} The implicated allergen for peach allergy, originally mostly reported in countries like Spain, Italy, and Greece, is the non-specific lipid transfer protein (LTP), that is, Pru p 3. IgE antibodies against Pru p 3 are associated with an increased risk for severe systemic reactions,³⁶ and they can cross-react quite broadly to other fruits, as well as to tree nuts, legumes, and some vegetables.³⁷ This more “dangerous” profile of LTPs has been attributed to their high degree of protease (and food-processing) resistance. Another factor that may contribute to their higher risk profile is that they go into solution effectively at low pH only, i.e., in the stomach, resulting in the absence of an early oral warning signal. In addition to Bet v 1-related allergens and LTPs, tree nuts, legumes, and seeds contain far more abundant seed storage proteins, such as 2S albumins, and 7S and 11S globulins. These proteins are involved in direct sensitization, which often occurs at younger ages. As reported for LTPs, these seed storage

Textbox 6 Short introduction on the production of IgE antibodies to conventional protein allergens

A cardinal feature of an allergen is the ability to induce the production of IgE antibodies. The first step to initial IgE antibody production is the activation and expansion of naive allergen-reactive IgM-producing B cells. This process depends on the interaction between various cells (in particular dendritic antigen presenting cells and T helper cells) and the production of many cytokines. IgE antibody production is a process that depends on signals provided by T-helper cells that are skewed by innate signals to become Th2 cells. Properties of allergen molecules can contribute to the innate process driving towards Th2 immune responses.^{38–40} Major Histocompatibility Complex-II (MHC-II) molecules present peptides derived from the protein to Th2 cells. The T cell receptor interacts with the peptide-MHC-II complex, which results in activation of the T cell. This activated T cell can activate B cells, but only if these B cells have the same peptide in their surface-anchored MHC-II. In contrast to the antigen-presenting cell, the B cell can only ingest antigens if the antigen binds to the surface-anchored unique antibody of that B cell. These B cells ingest and digest the protein and present the peptides in its MHC-II to the T cell. The B cell further activates the T cell, which results in the production of cytokines by the T cell. The T cell activates the B cell, which results in differentiation of the B cell to an antibody-secreting plasma cell. The activated IgM-producing B cells can differentiate to change their isotype by a process called class-switch recombination (which results in a change in isotype production from IgM to IgG1, IgG4, IgA1, etc., and sometimes to IgE) and to increase their affinity by a process called somatic hypermutation. Both processes result in irreversible changes in the DNA of the B cell. The discovery of the crucial role of IL-4 produced by Th2-cells (and other cells) in the generation of IgE responses is a milestone in the history of allergy.^{41,42}

proteins, in particular the 2S albumins, are remarkably stable and IgE antibodies against them proved to be better markers for predicting a positive double-blind placebo-controlled food challenge, that is, for clinical allergy. They are also associated with more severe symptoms. This was first demonstrated convincingly for peanut Ara h 2,³¹ but hazelnut 2S (Cor a 14) and 11S (Cor a 9) play such a role as well^{43,44}; however, for hazelnut allergy as a whole, they would not qualify as major allergens because birch pollen-associated hazelnut allergy is the dominant phenotype.⁴⁵ This illustrates that minor allergens can be of major clinical relevance. Based on these and other observations, molecular diagnosis is increasingly used for attempts to reliably assess the risk of patients to experience severe symptoms. In

some more recent papers, models combining molecular recognition profiles and clinical and demographic background have been proposed to improve severity risk assessments.^{45,46}

8 – The allergenic risk spectrum

Some allergens are considered more dangerous than others in that they elicit more severe allergic symptoms. By contrast, some IgE inducers are not really allergens at all because they do not induce symptoms. The prevalence of such cases has often been underestimated because they are rarely detected in the doctor's office. They used to be identified mostly in population surveys and birth cohort studies. This situation is changing, particularly since the introduction of the large allergen microarrays, as discussed in Chapter A04. Peanut is a prototypic example of an allergenic source material to which many people have IgE antibodies, but they can often freely consume peanuts. Finding IgE to peanuts in peanut-tolerant subjects is particularly common among pollen-sensitized patients.⁵¹ This association is due to IgE cross-reactivity between allergens from pollen and (glyco-)proteins in peanut and many other vegetable sources. Bet v 1-related cross-reactivity has been discussed above. Peanut contains a cross-reactive homologue, Ara h 8. However, cross-reactivity has also been evident between peanut and grasses, which do not have a cross-reactive Bet v 1 homologue. Profilin and CCD have been found to be the most likely additional cross-reactive substances.^{17,52} It has been convincingly demonstrated that CCD-specific IgE antibodies are of limited if any clinical relevance.⁵³ It is tempting to assume that all nonsensitizing cross-reactive allergens are relatively safe. While this is true in many cases, severe reactions caused by exposure to such presumed nonsensitizing cross-reactive allergens have been reported. A more recent addition to the spectrum of highly cross-reactive structures that clearly demonstrates this are the nonprimate mammalian α -Gal sugar moieties present in red meat that are associated with delayed severe reactions.²⁰ In general, however, the relatively low biologic activity of cross-reacting allergens may reflect lower epitope density and lower affinity of the IgE-allergen interaction, but it has been disappointingly difficult to predict biologic activity on the basis of immunochemical characteristics in individual cases. The use of a bioassay such as the basophil activation test is a promising alternative.⁵⁴ In addition, other experimental assays will further help to define the biological activity of individual IgE-binding molecules.⁵⁵ Allergen sources are complex, heterogeneous mixtures of proteins. They contain harmless IgE-binding structures such as CCD, molecules that induce mild symptoms only and molecules that are associated with severe symptoms including food or insect venom-induced anaphylaxis. Moreover, molecules can inform us about the origin and route of sensitization, sometimes reflected in clear geographic differences. Dissection of these molecular characteristics of allergen sources is of the utmost importance to improve allergy diagnosis, prevention, and therapy.

Textbox 7 Allergen cross-reactivity and its assessment

Two allergens are cross-reactive if antibodies exist that recognize both allergens. The antibody will usually have a preference for one allergen over the other. This preferential recognition provides a clue as to identify of the more relevant of the two allergens. A single allergen molecule has several IgE-binding regions (called epitopes). Among IgE antibodies to the birch allergen, Bet v 1, that are induced by inhaling birch pollen, two types of antibody populations can be distinguished based on their reactivity with Mal d 1, the homologous protein of apple. Some IgE anti-Bet v 1 antibodies will not react with Mal d 1, because they are directed to a nonconserved part of Bet v 1. Other IgE antibodies will react not only with Bet v 1 but also with Mal d 1. The latter reaction will usually be of lower affinity. In this example, Bet v 1 can be shown to be a more complete allergen than Mal d 1. Grass pollen extract does not at all inhibit the binding between IgE anti Bet v 1 and Mal d 1 (because grass pollen extract does not contain a cross-reactive Bet v 1 homologue). In this way, it is possible to rank allergen source materials (such as birch, apple, celery, and peanut) in a cross-reactivity hierarchy. This is most reliably done by using a quantitative bi-directional cross-inhibition protocol,⁴⁷ but less demanding protocols may also be informative. Some cross-reactions are relatively restricted (example: cross-reactivity among grasses). Others are broader (example: Bet v 1/Mal d 1, with much lower cross-reactivity to the homologous protein in peanut, celery and potato and no cross-reactivity with grasses). Others cross wider phylogenetic barriers (examples: cross-reactivity between pollen from birch and grass due to profilin^{48a,48b} and cross-reactivity between shrimp and mites due to tropomyosin)⁴⁹. Among the glycan epitopes, CCDs tend to be even more cross-reactive (example: cross-reactivity between bee venom and potato).¹⁶ Glycan-based cross-reactivity is different from protein-based cross-reactivity because the degree and fine structure of glycosylation is variable among glycoproteins, even at the single-cell level.^{50a} It is not unusual to find that 2 allergen source materials share several distinct cross-reactive molecules. An example is the cross-reactivity among birch pollen, vegetables and fruits, which was found to be due to at least 3 cross-reactive structures.^{50b}

9 – Molecular sensitization profiles: biomarkers for disease progression?

A relatively unexplored area is whether IgE recognition profiles have predictive value for disease progression. This field will most likely develop rapidly in the near future. Some evidence from the field of food allergy suggests that recognition profiles of specific epitopes on major food allergens, using short synthetic peptides, can predict outgrowth or persistence.⁵⁶ Another study reported that persistence of peanut allergy is associated with the number of peanut allergens recognized.⁵⁷ More recently, IgE against Der p 1 and in particular Der p 23 at young age was shown to be predictive for development of asthma later in life²⁸. These studies are just the beginning and illustrate the importance of carefully dissecting molecular composition of allergen sources.

10 – Allergen extracts: imperfect but not yet obsolete

Both allergy diagnostics and allergen immunotherapy (AIT) still heavily depend on extracts of the allergen sources. In particular in diagnostics, molecular approaches are gaining ground⁵⁸ rapidly, but extracts can certainly not be dismissed.⁵⁹ Usually, allergen extracts are simple aqueous extracts of the crude allergen source. In most cases, extraction is carried out at neutral or close to neutral pH, followed by a defatting step, and dialysis. In the case of food extracts, the source material may sometimes be partially processed before extraction, for example, peanut meal of mildly roasted peanuts. What are the potential shortcomings of allergen extracts? Allergen sources are biologic products with inherent variability of composition. Extraction with aqueous buffers at neutral pH may not optimally extract all possible allergens, especially those that are lipid-soluble. This is particularly relevant for food extracts because the natural route of exposure through the stomach includes exposure to low pH. A good example of a food allergen that is not optimally extracted at neutral pH is LTP from legumes such as peanut and lentils.⁶⁰ This phenomenon may also be the explanation for the huge variability in LTP content reported for a series of commercially available skin test reagents for hazelnut allergy.⁶¹ Extraction at low pH has proven to be the solution. Another problem encountered when preparing diagnostic food extracts, in particular of fruits and vegetables, is that enzymatic oxidative processes are initiated when the food tissue is disrupted. In particular, Bet v 1-related food allergens such as Mal d 1 in apple, Pru p 1 in peach, or Cor a 1 in hazelnut are sensitive to these processes and they lose their IgE-binding capacity. Finally, the defatting step has been implicated in loss of lipophilic allergens such as oleosins in legumes, nuts, and seeds.⁶² Together, these

shortcomings are probably the main reason that skin testing for many foods is performed using the poorly standardized but more sensitive prick-to-prick method with fresh foods. To overcome the loss of sensitivity for detecting IgE antibodies against hazelnut Cor a 1, the extract can effectively be improved by spiking with recombinant Cor a 1. Although Good Manufacturing Practices (GMP) requirements do not facilitate broad *in vivo* application of recombinant allergens, for example, recombinant Mal d 1 has been successfully used in skin testing, oral challenges and sublingual immunotherapy.⁶³⁻⁶⁵

11 – Conclusion

Overall, one can conclude that the multitude of factors influencing extract composition results in batch-to-batch and company-to-company differences, which may lead to differences in the diagnostic and therapeutic management of patients. For several reasons, this is

particularly true for skin test reagents. Traditionally, these products are provided for free by allergen manufacturers to support the selection and subsequent sales of immunotherapy products. Regulatory pressure now requires skin test reagents to be registered. This development has resulted in many “less important” allergen specificities being removed from the market, because they would require too big an investment in documentation of their clinical performance. Potential solutions such as spiking with recombinant allergens are not really an option either, because recombinant allergens used *in vivo* need to be produced under GMP conditions and tested in toxicity studies. Again, this is too large an investment. In the future the number of skin test reagents available will therefore be rather limited, and extracts for *in vitro* diagnosis will continue to be improved by the use of different extraction methods and/or spiking. Increasingly, molecular diagnostics will supplement and partly replace extract-based tests, to overcome the imperfections of extracts and facilitate improved risk assessment and subsequent advice to patients.

A03 – Molecular allergy diagnostics in clinical practice

Thilo Jakob, Paolo M Matricardi, Olga Luengo and Jörg Kleine-Tebbe

Highlights

- Diagnostic work-up for IgE-mediated allergic reactions/diseases starts with the history, followed by sensitization tests (skin, IgE, and basophil tests) and optional challenge tests.
- Molecular allergens for IgE testing provide additional information, particularly in polysensitized patients and with allergens of low abundance, low stability, or associated risks.
- IgE-reactivity to members of the same allergen family reflects the degree of protein homology and IgE cross-reactivity. If it is high, the relevance needs to be sorted out. In case it is low, selected IgE testing of other family members can provide additional information.
- Proper interpretation should complete diagnostic testing: positive sensitizations to allergen extracts or molecules are only clinically relevant in case of corresponding symptoms.

Conventional allergy diagnostics are based on detecting specific IgE antibodies in the blood or skin with reactivity for allergen extracts obtained from various allergen sources such as pollen grains, house dust mite, or cat dander. These extracts contain many components (glycosylated and nonglycosylated proteins, lipids, etc.), the majority of which are irrelevant for the allergic reaction and allergy diagnostics. Progress in molecular biology over the last 3 decades has allowed us to identify and characterize single allergens in detail at a molecular level. Large allergen data banks have been established (e.g., www.allergen.org, www.allergome.org) in which information on identified allergens is accessible for the scientific and medical community. Currently as of December 2022, more than 4900 different allergens (plus approx. 1500 isoforms) have been described (www.allergome.org), almost 1500 of which have been expressed as recombinant proteins. Many of these allergens have already and will become available for *in vitro* allergy diagnostics, either as highly purified native or recombinant proteins. The use of single allergenic molecules (instead of extracts) has introduced a new area of high-resolution molecular allergy diagnostics (also designated “component resolved diagnostics,” CRD⁶⁶) and changed our understanding of sensitization profiles and cross-reactivity.⁶⁷ Daily routine molecular allergy diagnostics offers a number of benefits that give us a higher diagnostic precision and allow for better management of the patient. To utilize the full potential in clinical practice, an in-depth general knowledge of molecular allergology and a clear rationale for their use are needed as it relates to when and how allergenic molecules are to be used for diagnostic purposes (“always think molecular—use molecules, when needed”).

This section

- summarizes general considerations for the diagnostic workup of our allergy patients in the age of molecular allergology,
- provides a number of universal reasons to utilize molecular diagnostics, and

- describes the rationale behind different approaches (“from symptoms to molecules”; “from molecules to symptoms”) that allow us to make the optimal use of molecular allergy diagnostics in clinical practice.

1 – General considerations for the diagnostic work-up of allergy patients

In patients with suspected IgE-mediated reactions and/or diseases, the diagnostic algorithm should include the following sequential steps (Figures 1 and 2):

A. Clinical evaluation and examination

- a. allergy-related history including information on comorbidities, differential diagnoses.
- b. clinical examination.

B. sensitization test(s) with allergen extracts, i.e., skin prick tests SPT,⁶⁸ sIgE tests,⁶⁹ basophil activation tests,¹⁵⁶ providing information on allergic sensitization, i.e., the “risk for allergy.”

B1. indirect or direct evidence of allergen-specific IgE

B3. interpretation of sensitization test result(s) (clinical relevance or not?).

B2. Sensitization test with allergenic molecules (applying allergen-specific IgE tests).

B2. direct evidence of present or absent allergen-specific IgE to defined allergens? *(sIgE to the complete extract is needed to interpret the result of sIgE to single allergenic molecules).

B3. interpretation of sensitisation test result(s) (clinical relevance or not?)

C. Challenge test (optional, depending on the allergen source in question).

- a. demonstration of clinical symptoms upon allergen exposure.
- b. interpretation (qualitative conclusion: positive or negative? quantitative conclusion: ratio component sIgE/whole extract-sIgE allows to determine the extent to which a given allergenic component is responsible for sensitization to a whole extract⁷⁰).

For each of these steps certain general considerations may be helpful to make the best out of our expanding knowledge of the molecular nature of allergens. These considerations are listed below and combined with examples from clinical practice (small italic font).

A. Some history-related information might immediately suggest certain underlying allergenic molecules (“think molecular”), due to

- temporal relationship of symptoms with particular exposures (i.e., pollen, furry animals, house dust, certain foods).
- patient's observation of certain triggers representing particular pattern (related triggers, i.e., indicative selection of foods),
- degree and variety of symptoms indicating involvement of certain molecules (either mild oropharyngeal or severe systemic

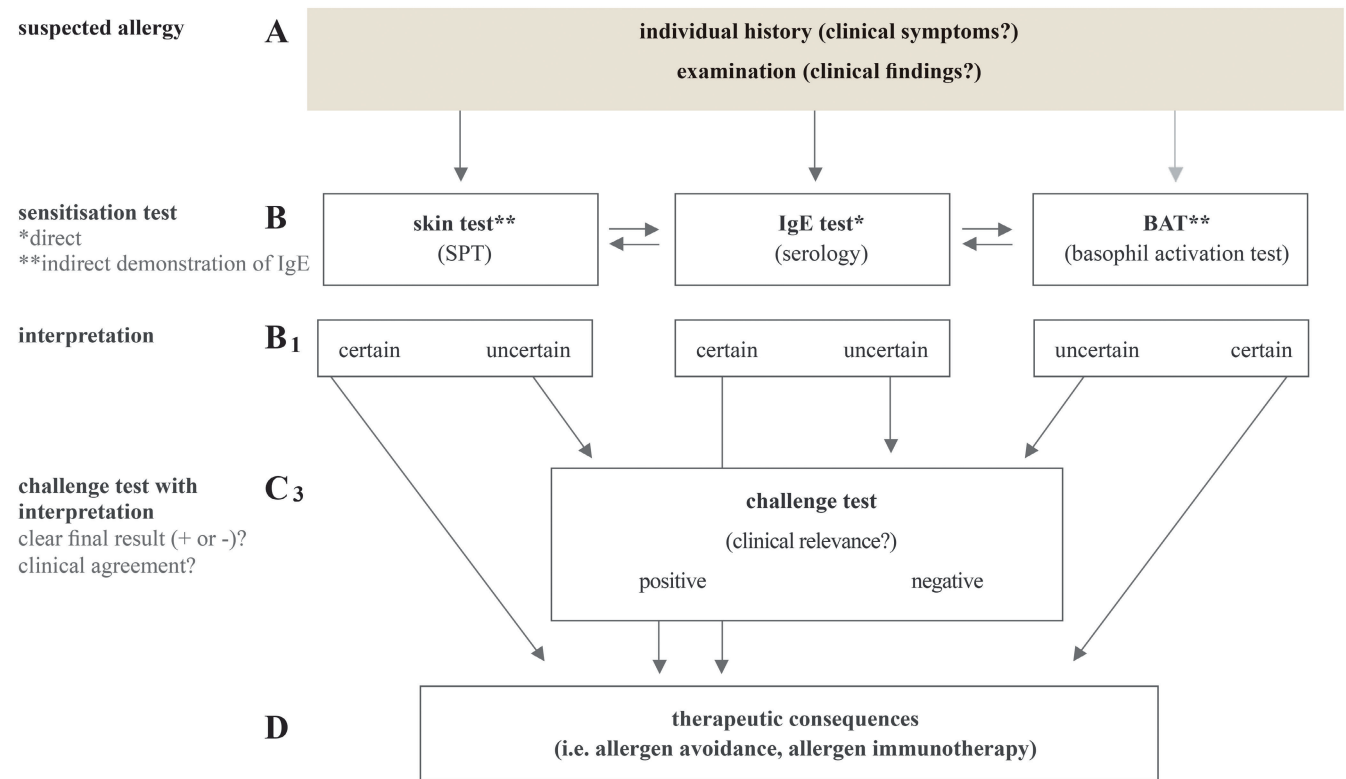


FIGURE 1 General diagnostic work-up of IgE-mediated allergic reactions and diseases. After collecting the allergy history and performing a physical examination (A) appropriate sensitization tests are applied (B1). IgE sensitizations are directly demonstrated by serological allergen-specific IgE determination⁶⁹ and/or indirectly by skin prick tests (SPT)⁶⁸ or basophil activation tests (BAT),¹⁵⁶ if indicated. Sensitization tests should be completed by careful interpretation (B1), validating the agreement with the history to ultimately evaluate the clinical relevance of the obtained results. In case of uncertainty (B1), i.e., due to a nonconclusive history, challenge tests are applied (C) to induce allergic symptoms under controlled conditions.^{70,71} A clear outcome will support the decision on the clinical relevance of suspected allergen triggers and provide the basis for potential therapeutic consequences (D).

symptoms to, i.e., legumes, tree nuts or seeds) (potential marker allergens).

Examples:

Oropharyngeal symptoms after eating raw apples, hazelnuts, carrots and/or soy and/or symptoms of allergic rhinoconjunctivitis during the birch pollen season: Suggestive for the presence of IgE to major birch pollen allergen Bet v 1-specific with subsequent serological (and clinical) cross-reactions (primary inhalant sensitization, but due to structural similarity of Bet v 1 and its homologues secondary symptoms in the oral cavity upon exposure).

Oropharyngeal symptoms after eating various (nonrelated) fruits and vegetables such as melon, citrus fruits, banana, avocado AND symptoms of allergic rhinoconjunctivitis during the grass pollen season: Suggestive for IgE to minor (grass) pollen allergen profilin (i.e., timothy grass profilin Phl p 12) with subsequent serological (and clinical?) cross-reactions. (nota bene: profilin sensitization is variable depending on the geographical region and more prevalent in Central and Southern Europe or other geographical areas with similar climate and vegetation)

Anaphylaxis in the context of exercise after consumption of wheat-containing food, which is suggestive for IgE to omega-5 gliadin Tri a 19.

B1. Some sensitization test results with extracts, either by SPT or serology, might immediately suggest certain underlying allergenic molecules, i.e.:

- particular pattern of sensitization, pointing to cross-reactive molecules
- unusual pattern or magnitude of sensitization test results (i.e. to non-related allergen sources)

Examples:

Positive reactions to fagales tree (hazel, alder, birch, beech, oak) pollen, potentially with symptoms during the tree pollen season:

Suggestive for the presence of IgE to the major birch pollen allergen Bet v 1 with subsequent serological (and potential clinical) cross-reactions to related fagales trees.

Positive reactions to nonrelated pollen plants, sometimes all pollen sources, with various, not necessarily corresponding symptoms: Suggestive for the presence of IgE to pan-pollen allergens (profilins, i.e., Bet v 2 or Phl p 12 and/or polcalcins, i.e., Bet v 4 or Phl p 7) with subsequent serological (and clinical?) cross-reactions to profilin-containing pollen and plant foods as well as polcalcin-containing pollen. In case of double sensitization to

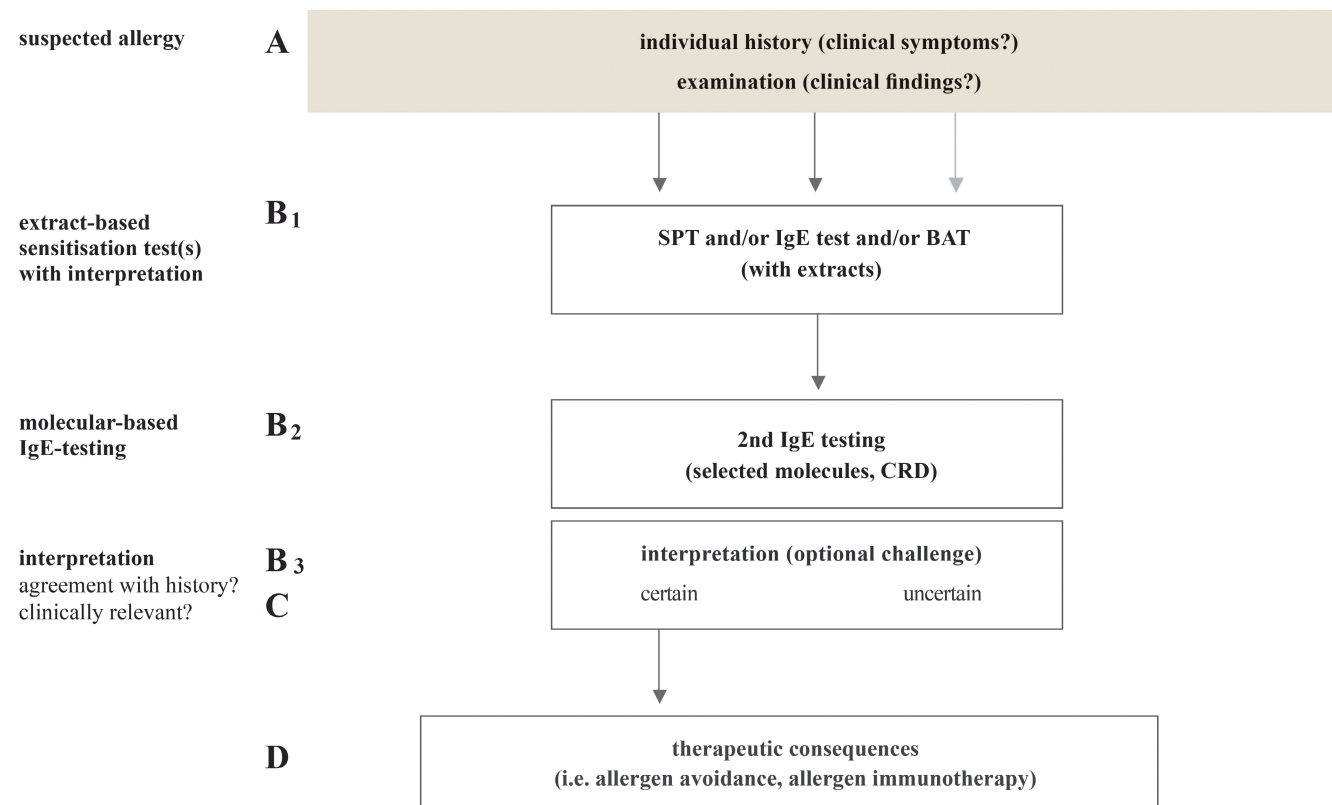


FIGURE 2 Diagnostic work-up with targeted (singleplex) molecular-based IgE testing. After sensitization testing (B1) with allergen extracts, more detailed information regarding the IgE repertoire is obtained with molecular-based testing (B2). This diagnostic approach, coined “top-down” is followed by a thorough interpretation (B3) including challenge tests (C), if needed.

profilin AND polcalcin: commonly positive reactions to ALL pollen species can be expected, and it is not possible to define the precise sensitization specificity with allergen extracts.

Multiple sensitizations to different furry animals, which is suggestive of IgE reactivity to the animal pan allergen serum albumin or certain lipocalins.

B2. Tests for allergen-specific IgE to molecules (Figure 2) can be applied with one reagent as single test (singleplex)⁶⁹ or with many reagents (multiplex)⁷¹ for, i.e., screening purposes (see chapter A04 for more technical information). Reasons for molecular IgE testing, either singleplex or multiplex, will be summarized below (see also paragraph 5 of this chapter). Following options will be extensively discussed in the following sections:

- “Classical” diagnostic work-up (Figure 1) with extract-based sensitization test(s), before employing allergen-specific IgE testing with molecules (Figure 2) (“top-down approach,” paragraph 3 of this chapter).
- Novel diagnostic work-up with primarily allergen molecule-related information, i.e., allergen-specific IgE to a panel of related molecules to explain diverse clinical reactions or diseases (“bottom-up approach,” paragraph 4 of this chapter).

- Integrated use of both approaches, first working from the history, applying extract-based sensitization tests (SPT, IgE) before exploring the entire individual IgE repertoire with an extended panel of allergen molecules (“U-shape approach,” paragraph 5 of this chapter).

C. Finally, if the information provided by the patient's history and/or the sensitization test results is inconclusive and does not allow for a clear decision on the clinical relevance of the suspected allergen source, additional challenge tests should be applied. They should ultimately demonstrate or rule out clinical symptoms following allergen exposure.

In case of inhalants (pollen, mites, molds, furry animals) standardized extracts of the suspected allergen source are applied on the mucosal surface (i.e., conjunctiva, nose).⁷² In case of food allergy (plant foods, i.e., fruits, vegetables, legumes) increasing doses of the suspected allergen are given orally, ideally in a double-blind, placebo-controlled fashion.^{73,74}

Subsequent immediate or delayed (i.e., exacerbation of an atopic eczema) type allergic symptoms would prove current clinical relevance; by contrast, a lack of any objective clinical reaction would rule out a previously suspected allergy (provided that no additional co-factors are required to elicit the allergic reaction, as exemplified by all forms of food-dependent, exercise induced anaphylaxis.⁷⁵

Subsequently, interpretation needs to be integral part of any suspected sensitization (i.e., demonstrated by SPT, IgE, BAT) as well of a challenge test outcome (Figure 1).

- A positive test result is only clinically relevant in the case of corresponding allergic symptoms that are temporally associated with a defined allergen exposure.
- A negative test (i.e., allergen-specific IgE) result against one recombinant allergen molecule or a mixture of natural isoforms of one single allergen can indicate exclusion of allergic sensitization or risk of allergy to the allergen in question (see paragraph 5 of this chapter for details), provided that
 - a. the total IgE is high enough (i.e., > 20 kU/l)
 - b. the allergen reagent is of sufficient abundance, fully intact, and presenting all its epitopes
 - c. the analytical performance of the IgE antibody assay has been optimized for a low limit of quantitation (i.e., 0.1 kU/L).

Electronic clinical diaries (e-Diaries) have been recently proposed as an additional diagnostic tool to establish clinical relevance of IgE sensitization to major allergenic molecules of pollen.⁷⁶ The use of e-Diaries has been integrated in a novel diagnostic algorithm, combining CRD with digital health, for etiological diagnosis and allergen immunotherapy (AIT) prescription (@IT.2020). The implementation of this algorithm has been tested in a multicenter study in several southern European countries, where polysensitization to cross-reactive pollen and overlapping pollen season make the etiological diagnosis difficult.⁷⁷

In conclusion, the clinical relevance of an allergic sensitization (i.e., presence of allergen-specific IgE, independent of the use of allergen extracts or molecules for diagnostic purposes) can ultimately only be determined by the physician and not by the test. Therefore, the complete diagnostic results of sensitizations and challenge test results will always have to be interpreted within the clinical context and on the basis of the individual's case history.

2 – Common reasons to utilize molecular diagnostics and their limitations

There are several general reasons that speak in favor of using single allergens as compared to allergen extracts (Figure 3). They are principally related to an improved assay performance (i.e., assay sensitivity and analytical specificity) and/or to additional levels of interpretation such as risk assessment or differentiation between genuine (“primary”) sensitization and cross-reactivity, particularly in presumed polysensitizations. While these arguments clearly support the use of single allergens in clinical routine, we need to be careful not to over interpret results of molecular allergy diagnostics, which have clear limitations when it comes to predicting clinical outcomes. sIgE test results—regardless of using extracts or single molecules—only reflect the status of sensitization and always must be interpreted in the context of the clinical data. The benefits and limitations of molecular allergy diagnostics are outlined below.

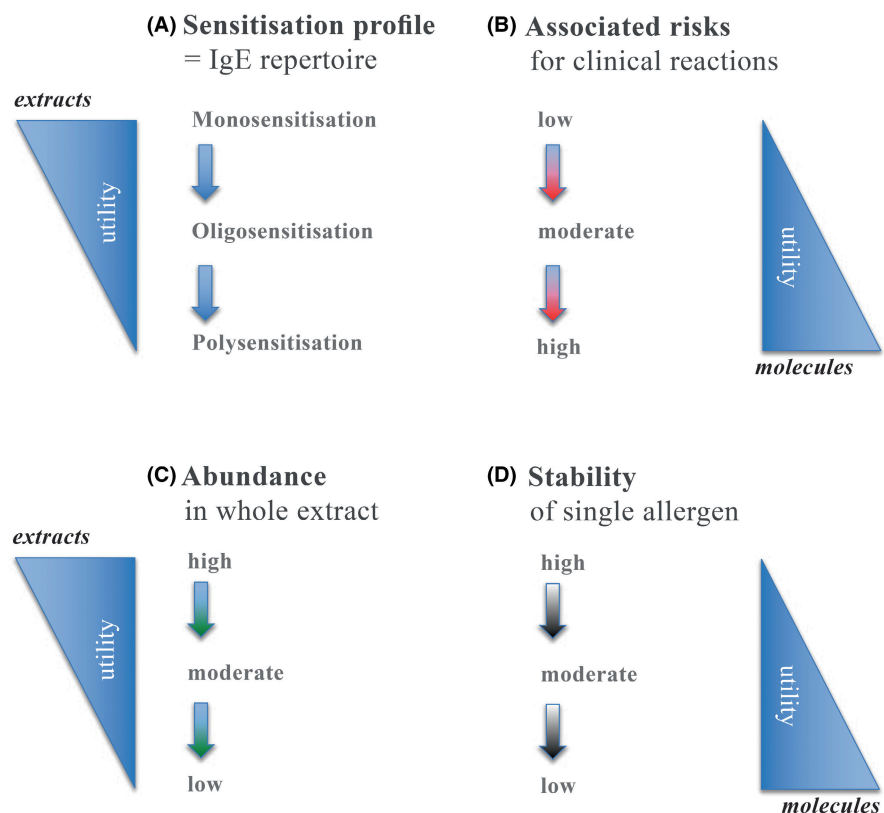


FIGURE 3 Utility of allergen extracts and allergenic molecules for diagnostic work-up. Mono/limited oligo sensitizations (A) and/or minor clinical risks (B) as well as high abundance allergen molecules in the allergen source suspected (C) and/or allergens of high stability (D) indicate suitability of allergen extracts for proper diagnostic work-up. In case of polysensitizations and/or allergen triggers associated with high clinical risks as well as low abundant and/or labile allergenic molecules in the extract, the diagnostic work-up should consider the use of molecular components for IgE detection.

2a Factors improving assay performance are able to warrant the use of allergenic molecules instead of extracts:

Molecules of low abundance and/or weak stability

If allergen molecules, being of low abundance or missing in the extract, can improve the assay's analytical sensitivity (LoQ) of an IgE test, their use is meaningful and important. (i.e., *Gly m 4 vs soy extract, omega-5-gliadin vs wheat extract*).

Risk- or severity-associated molecules

If allergen molecules provide improved analytical specificity ("selectivity") and allow additional clinical assumption(s) (i.e., *increased risk association, clinical severity, or other associated clinical features of an IgE sensitization*), their use is a gain meaningful and recommended (i.e., *storage proteins Ara h 1, 2, 3, 6 vs whole peanut extract*).

Indicator of cross-reactivity

Certain allergen molecules can serve as indicators for serological cross-sensitizations through the binding of cross-reactive IgE. In case of a positive result, they can demonstrate the lack of analytical specificity of an IgE test with allergen extracts (in affected subjects with potential cross-reactions) (e.g., *profilin or polcalcin, members of plant pan-allergen families*).

Marker of genuine (species-specific) sensitization

Particular allergen molecules (often major allergens) can serve as markers for a primary, "genuine," family- or species-specific sensitization. They provide improved analytical specificity compared with allergen extracts (particularly in affected subjects with potential cross-reactions) (e.g., *marker allergens Ves v 1 and Ves v 5 from yellow jacket venom and marker allergens Api m 1, Api m 3, Api m 10 from honey bee venom vs hymenoptera whole venom preparations from the corresponding species*). The above rationale is primarily based on the status of sensitization (presence or absence of IgE antibody) and not on the clinical manifestations of the subjects. Examples are given in more detail below.

2b Limitations in improving predictions on clinical outcome from (isolated) molecule-based sensitization test results

In contrast to parameters that describe the analytical assay performance (analytical sensitivity, analytical specificity, see above), clinical diagnostic criteria are required when it comes to making predictions on the clinical outcome. General clinical diagnostic criteria in the field of (molecular) allergology include:

- I diagnostic sensitivity (proportion of positive IgE antibody tests in patients with allergic symptoms/disease).
- II diagnostic specificity (*proportion of negative IgE antibody tests in asymptomatic/healthy individuals*).
- III indicator of clinical cross-reactivity (*allergic symptoms to allergenic sources that did not elicit the primary sensitization*).
- IV prediction of clinical reactions (*positive predictive value, PPV, negative predictive value, NPV, thresholds, likelihood ratio etc.*).

All of the above criteria require a thorough individual interpretation of each test result based on the previous history and if

needed additional proof of reproducible and objective symptoms in the affected allergic subject upon exposure (i.e., challenge test). Subsequently, these clinical criteria will go beyond the essential ("raw") assay result of an allergen-specific IgE test (IgE sensitization in question: yes or no). In general, clinical diagnostic criteria are:

- less suitable and sometimes misleading for a proper assay evaluation of sensitization tests
- largely not needed to demonstrate the advantage of single allergenic molecules in IgE assays and
- often burdened with unsatisfactory study results due to the per se limited and imperfect prediction of clinical outcomes (clinical reactivity) by sensitization tests.

In conclusion, the above listed advantages of molecular allergy diagnostics mostly refer to an improved detection and discrimination of allergic sensitization. Molecular allergy diagnostics, however, have clear limitations for improving predictions of the clinical outcome. After all, the detection of sIgE is primarily an indicator of "sensitization" and—despite various attempts to integrate clinical data and results of challenge tests—not a decisive predictor of clinical reactivity.

3 – From symptoms to molecules: the "top-down approach"

Based on the experience that detection of allergen-specific IgE does not equal clinical relevance, current guidelines on allergy diagnostics recommend that the diagnostic workup should be primarily guided by the clinical symptoms. Random screening for IgE sensitization is discouraged since the number of positive IgE results to a certain allergen source usually exceeds by far the number of clinically relevant allergies.⁷⁸ This "top-down" approach—from the symptoms to the allergen source also applies to molecular allergy diagnostics and can be defined as follows:

Definition: Diagnostic work-up from symptoms to molecules ("top-down approach," [Figure 2](#)) aims for more detailed characterization of the IgE repertoire unfolding important molecular IgE sensitizations that provide information beyond the extract-based test results.

In practice, taking the case history and performing a symptom guided diagnostic work-up with extract-based SPT and/or IgE testing usually allows the identification (or exclusion) of IgE sensitizations to potentially involved allergen sources ([Figure 1](#)). Here two main scenarios are usually encountered:

A Limited numbers of positive extract-based sensitization test results

In case of rather restricted IgE antibody responses with only few positive results to inhalants like tree or grass or weed pollen, certain molds, one or two furry animals, only a single insect venom (bee or wasp venom) or only selected food items, the analytical specificity of an extract-based sensitization test might be sufficient to identify the underlying allergen source. No further testing would be required, if the extract-based sensitization test permits

a proper and specific diagnostic work-up. The exceptions are potentially false negative sensitization tests in case of underrepresented or unstable single allergens.

B Broad panel of positive extract-based sensitization test results

More frequently we encounter the scenario in which rather broad IgE antibody responses occur with many positive results to extracts from inhalants or reported symptoms to many (plant) foods. This indicates possible cross-reactivities and a lack of analytical specificity of the extract-based test approach.

In this setting, further work-up ("top-down approach," [Figure 2](#)) with allergen molecules may allow a more detailed and meaningful characterization of the IgE repertoire, identifying important molecular IgE sensitizations. Examples of situations in which molecular allergy diagnostics provide additional information beyond the extract-based tests are listed below:

3.1 Examples of situations for further molecular diagnostic work-up

3.1.a. Allergen source with potentially competing clinically relevant allergen sources

- Multiple sensitizations to (nonrelated) pollen species (i.e., from trees, grasses, weeds) with overlapping seasons

Examples: pollinating plants (trees, grasses, weeds) with overlapping seasons. Here the use of marker allergens and pan allergens allows discrimination between genuine sensitization and cross-reactivity.

- Symptoms to multiple (nonrelated) plant foods due to potential cross-reactivity.

Examples:

- apples, hazelnuts, cherries, plums, peaches, carrots, soy (suggesting Bet v 1-cluster, predominantly in the northern hemisphere with birch trees)*
- melon, banana, apples, nuts, peanut, citrus and others (suggesting profilin-cluster, often due to high regional grass pollen exposure)*
- peach, apple, lettuce, green bean, tree nuts, peanut and others (suggesting LTP-cluster, mainly in the Mediterranean region).*

- Multiple sensitizations to furry animals (with potential clinical consequences) *Examples: i.e., cats, dogs, horses, small furry animals (suggesting serum albumin or certain lipocalins as cross-reacting allergens).*

3.1.b. Allergen source with a variety of different single allergens, either resembling cross-reactive or genuine molecules.

- Anaphylactic Hymenoptera sting reaction and sensitization to both honey bee and yellow jacket venom.

- Both allergen sources contain potentially cross-reactive allergens such as Api m 2, Ves v 2 (hyaluronidases), Api m 5, Ves v 3 (dipeptidyl peptidases), Api m 12, Ves v 6 (vitellogenins), and marker allergens that are specific for honey bee venom (Api m 1, Api m 3, Api m 4, Api m 10) or yellow jacket venom (Ves v 1, Ves v 5). Use of marker allergens allows discrimination between genuine sensitization and cross-reactivity and may be important to prevent potential adverse reactions from immunotherapy or predict lack of allergen immunotherapy (AIT) efficacy
- Variable symptoms to certain plant foods
- *Examples: fruits, vegetable*
- Severe reactions to plant foods *Examples: peanut, soy, tree nuts, seeds.*

3.1.c. Immunotherapy prescription?

In the case of specific immunotherapy prescription it may also be relevant to assess if the sensitization to the allergenic source is mostly at the expense of the major allergen quantified and standardized in the commercial extract.

3.2. Criteria for selecting appropriate molecules (from an allergen source) ([Figure 5](#)). The general reasons given in section 2.a provide criteria to select certain molecules for further diagnostic work-up:

Bold letters indicate availability as reagents mainly non-USA, (e.g., Europe, Japan); regular letters: not (yet) available as reagents (see also section 2.a for explanations).

Molecules of low abundance and/or weak stability

*Examples: use major birch pollen allergen **Bet v 1** as a representative to demonstrate potential cross-reactivities to low abundant, labile **Bet v 1**-homologues, i.e., **Cor a 1.04** (hazelnut), **Act d 8** (kiwi), **Pru p 1** (peach), **Gly m 4** (soy), and others. Other examples of presently not well represented allergens are the peanut allergens **Ara h 10**, **Ara h 11**, **Ara h 14**, **Ara h 15** (oleosins), the wheat allergen **Tri a 19** (omega-5-gliadin), and natural rubber latex allergen (**Hev b 5** (acidic structural protein)).*

Risk- or severity-associated molecules

*Examples: 2S albumins, i.e., **Ara h 2**, **Ara h 6/7** (peanut), **Cor a 14** (hazelnut), **Gly m 8** (soy), other seed storage proteins **Ara h 1**, **Ara h 3**, **Cor a 9**, **Cor a 11**, **Gly m 5**, **Gly m 6**, nsLTP, i.e., **Pru p 3** (representative LTP marker allergen in peach, Mediterranean), **Cor a 8** (hazelnut, Mediterranean), **Ara h 9** (peanut, Mediterranean), other examples: **alpha-Gal** (delayed type red meat allergy).*

Indicators of cross-reactivity

*Examples: **Fel d 2**, **Can f 3**, **Equ c 3** (serum albumins); **Bet v 1**, **Act d 8**, **Ara h 8**, **Pru p 1**, (**Bet v 1**-homologues); **Amb a 8**, **Ara h 5**, **Art v 4**, **Bet v 2**, **Ole e 2***, **Phl p 12**, **Pru p 4** (profilins, pan-allergen in pollen and plant foods); **Amb a 10**, **Art v 5**, **Bet v 4**, **Ole e 3**, **Phl p 7** (polcalcins, pan-allergen in pollen); **CCD** (cross-reactive carbohydrate determinants)*

Markers of genuine (species-specific) sensitization

Examples: *Fel d 1* (cat), *Api m 1*, *Api m 3*, *Api m 4*, *Api m 10* (honey bee venom), *Ves v 1*, *Ves v 5* (*Vespula* species), *Bet v 1* (fagales), *Ole e 1* (olive tree, plantane), *Phl p 1*, *Phl p 5* (grass) *Art v 1* (mugwort), *Amb a 1* (ragweed), *Par j 2* (pellitory).

In summary, after taking the history and performing extract-based sensitization tests a diagnostic work-up including specific IgE to allergenic molecules is useful to increase assay sensitivity for single allergens of low abundance (in extracts) or weak stability. An increased analytical specificity will help to identify risk- or severity-associated allergens, indicators for cross-reactivity and marker allergens of genuine (primary) sensitization.

Interpretation is an integral part of each sensitization test: Positive results are only clinically relevant in case of corresponding symptoms; negative results can ideally rule out an allergic sensitization and subsequent clinical reaction to the tested allergen.

4 – From molecules to symptoms: the “bottom-up approach”

Instead of performing symptom-oriented focused molecular allergy diagnostics (“top-down approach,” see above), one can simply turn this approach around and start from the bottom, i.e., with the molecules.⁷⁹ In an ideal scenario, diagnostic tools would allow us to characterize the entire IgE repertoire to all potential allergens that

a patient has been exposed to. It would then be conceivable that we first analyze the entire IgE repertoire and then start talking to the patient to find out which of the detected IgE sensitizations are clinically relevant. This would be a “broad bottom-up approach,” i.e., turning the diagnostic pyramid upside down. However, a number of reasons suggest that in real life this is not appropriate: (a) We are far from being able to characterize the entire IgE repertoire, i.e., the individual IgE response to the entire allergome—currently only approx. 200 of the 3000 known allergens are available for diagnostic purposes. (b) An entire IgE repertoire characterization would be exceedingly expensive and yield enormous amounts of information that require processing and interpretation. (c) At present molecular allergy research attempts and multiplex technologies still depend on the availability of allergens for diagnosis. Many research projects have so far focused on certain molecules, i.e., *Bet v 1*-homologous proteins in various sources, leading to a broad spectrum of available proteins. However, this does not mean that this group is more relevant than other allergens to which less attention was paid in the past or which are more difficult to be produced as recombinant allergens. (d) Finally, the number of positive IgE results to a certain allergen source usually exceeds by far the number of clinically relevant allergies. Screening the IgE response to the entire allergome thus would most likely result in generation of large proportions of positive test results that have no clinical relevance (as it would be the case of performing extensive extract-based skin prick tests without the guidance of a previous thorough clinical history).

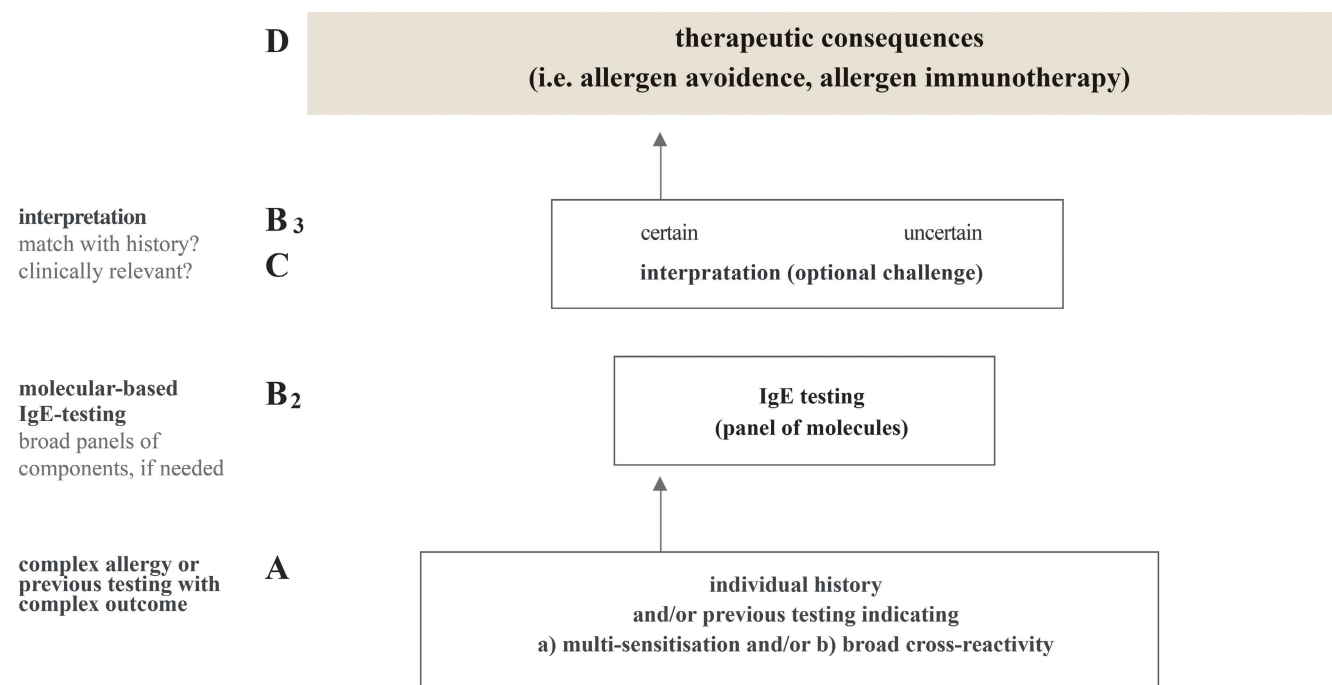


FIGURE 4 Diagnostic work-up with broad (multiplex) molecular-based IgE testing: In complex cases and/or inconclusive diagnostic outcomes after previous testing (A) a panel of molecular allergens might be applied for subsequent (multiplex) IgE testing (B2). After final interpretation (B3) with an optional challenge (C) this approach, coined “bottom-up,” might facilitate improved decisions on therapeutic consequences.

In conclusion, screening of IgE sensitization profiles to large panels of allergens irrespective of the clinical history ("broad bottom-up approach") is of limited value for the management of the allergy patient. However, there are a number of situations, in which a "targeted bottom-up approach," i.e., using molecular information and asking for corresponding symptoms can be helpful for patient management and consultation in clinical practice as outlined below:

Definition: Diagnostic work-up from (cross-reactive) molecules to clinical implications ("targeted bottom-up approach" [Figure 4](#)) aims for more detailed characterization of the IgE-repertoire or clinical reaction pattern unfolding important hints from a panel of potential molecular IgE-mediated cross-reactions. This diagnostic algorithm "targeted bottom-up approach" ([Figure 4](#)) is designated for molecular work-up in case of positive IgE to a certain, potentially clinically relevant cross-reactive molecule (protein family). The finding might explain broad cross-reactivities to other allergen sources if the candidate belongs to a protein family with many members of similar structure and a high degree of cross-reactive IgE recognition.

In clinical practice, the diagnostic work up in such cases (IgE to potentially clinically relevant cross-reactive molecules) can be based purely on clinical assessment to determine the relevance of potential symptom driving cross-reactivities, extending the clinical history or applying optional challenge tests with the allergen source in question.

Alternatively, or in addition, molecular IgE serology using the "targeted bottom up approach" i.e., screening for sIgE to corresponding cross-reactive allergens, may provide useful information on the presence or absence of cross-sensitizations.

The decision on which allergenic molecules have to be tested in this context should be based on the known degree of cross-reactivity. Here, two different patterns emerge:

1. Protein families with highly cross-reactive allergens do not require further IgE testing, but thorough clinical work-up to identify relevant clinical cross-reactions.

- A single IgE test is sufficient to demonstrate cross-reactivity to a prominent (most IgE-binding) member of an allergen family with broad cross-reactivity.
- Additional tests would only demonstrate more cross-reactions ([Figure 5B,C](#)) without addressing the clinical consequences (i.e., symptoms, clinical reactions).
- Subsequently, detailed clinical work-up is required to clarify potential clinically relevant cross-reactivities.

Reasoning: Further IgE tests would potentially create many (more) positive results with questionable clinical relevance. Therefore, the physician should sort out potential clinically relevant cross-reactions to related allergen sources in question containing a cross-reactive member of the same allergen family. In conclusion, it

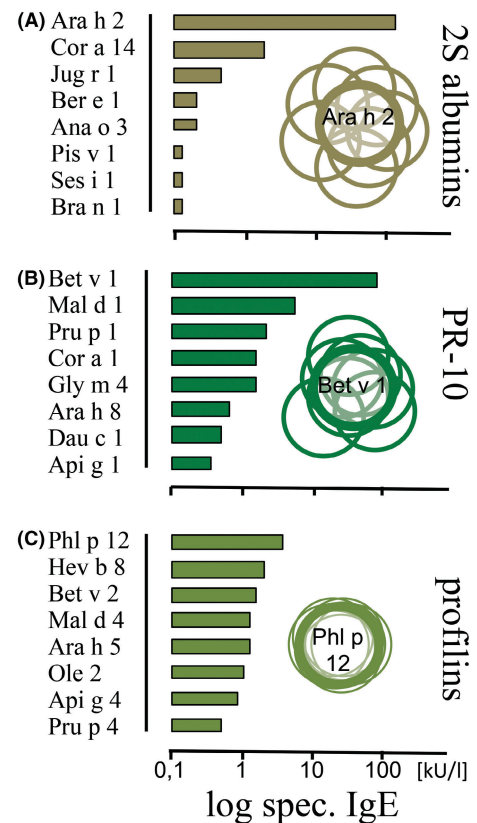


FIGURE 5 Allergen-specific IgE concentrations to various allergen molecules depending on structural similarity within one allergen family. A. Variable, limited cross-reactions (illustrated by circles with limited overlap) between different 2S-albumins (stable seed storage proteins in nuts, legumes and seeds) and corresponding IgE values (bars of various sizes) B. Cross-reactions of moderately limited variability (illustrated by circles with moderately limited overlap) between different Bet v 1-homologous food allergens C. High degree of cross-reactivity (illustrated by largely overlapping circles) between highly conserved, similar structures and epitopes of profilins (in pollen, foods and natural rubber latex) with corresponding IgE concentrations (bars of almost identical size).

is commonly sufficient to test only one member of a highly cross-reactive allergen family

Examples: Bet v 1 and its homologues, profilins, polcalcins (Ca⁺⁺-binding proteins), serum albumins, grass pollen major group 1 and 5 allergens, parvalbumins, tropomyosins.

2. Protein families with allergens of limited cross-reactivity are an option for further IgE testing, if an IgE test to a member of the same allergen family has been positive. In general, the highest IgE concentration to a member of the same family might indicate the primary sensitizer ([Figure 5A](#)). A negative result would generally exclude an IgE sensitization and make subsequent clinical reactions highly unlikely. However, in the case of a positive IgE result, only a thorough clinical work-up would be able to clarify potential clinically relevant cross-reactivities and subsequent reactions. If the case

history is not informative, a challenge test with the allergen source in question has to be applied to ultimately address the question of potential clinical relevance.

Reasoning: In case of allergens of limited cross-reactivity (see Figure 5A) an appropriate panel of related allergens (from the same protein family) could be used to demonstrate or exclude subsequent (serological) cross-reactivities. Therefore, additional IgE testing with related allergen molecules of the same family might establish a hierarchy of allergen-specific IgE values (Figure 5): Ideally the one with the highest IgE antibody level will represent the primary sensitizer. A negative result could exclude serological (and subsequently clinical) cross-reactivity. A positive result, however, would indicate serological cross-reactivity, which should be addressed with the patient according to her/his individual symptoms. Only in the case of corresponding symptoms, sometimes backed by an oral challenge, these cross-reactivities have to be considered in terms of present clinical relevance.

Examples: Seed storage proteins like 2S-albumins, 7S-globulins (vicilins), 11S-globulins (legumins); lipocalin subfamilies, nsLTPs

In conclusion, dissecting the relevance of a panel of related, cross-reactive allergens can be obtained by (a) a purely clinical work-up and/or (b) a further introduction of related, cross-reactive molecules. In case of negative IgE tests, serological and clinical cross-reactions can be ruled out with certainty. Positive IgE results would confirm serological cross-reactivity, the clinical relevance that needs to be addressed with the patient according to her/his

individual symptoms. This approach is only recommended for protein families with a low or limited degree of cross-reactivity (i.e., seed storage proteins, nsLTP), where the individual's IgE repertoire is highly variable and its binding to related molecules cannot be predicted.

5 – “U-shaped” molecular diagnostics in IgE-mediated diseases

Definition: A previous diagnostic work-up from symptoms to molecules (“top-down approach,” (Figure 2)) is combined with a subsequent diagnostic sequence from molecules to clinical implications (“targeted bottom-up approach,” (Figure 4)), coined “U-shaped molecular diagnosis” (Figure 6), dissecting the relevance of potential molecular IgE-mediated cross-reactions.

Satisfactory diagnostic conclusions after applying selected molecules (top-down approach) for IgE testing would result in appropriate advice to the patient without the need of further work-up (i.e., bottom-up approach).

However, if open questions remain, regarding the implications of potentially cross-reactive allergens after identification of one key allergen, the U-shaped molecular diagnosis (Figure 6) might help to solve the diagnostic problem. Subsequently, criteria for further molecular work-up after a previous “top-down approach” with the “bottom-up approach” have to be applied on an individual basis depending on the diagnostic outcome after the initial diagnostic steps.

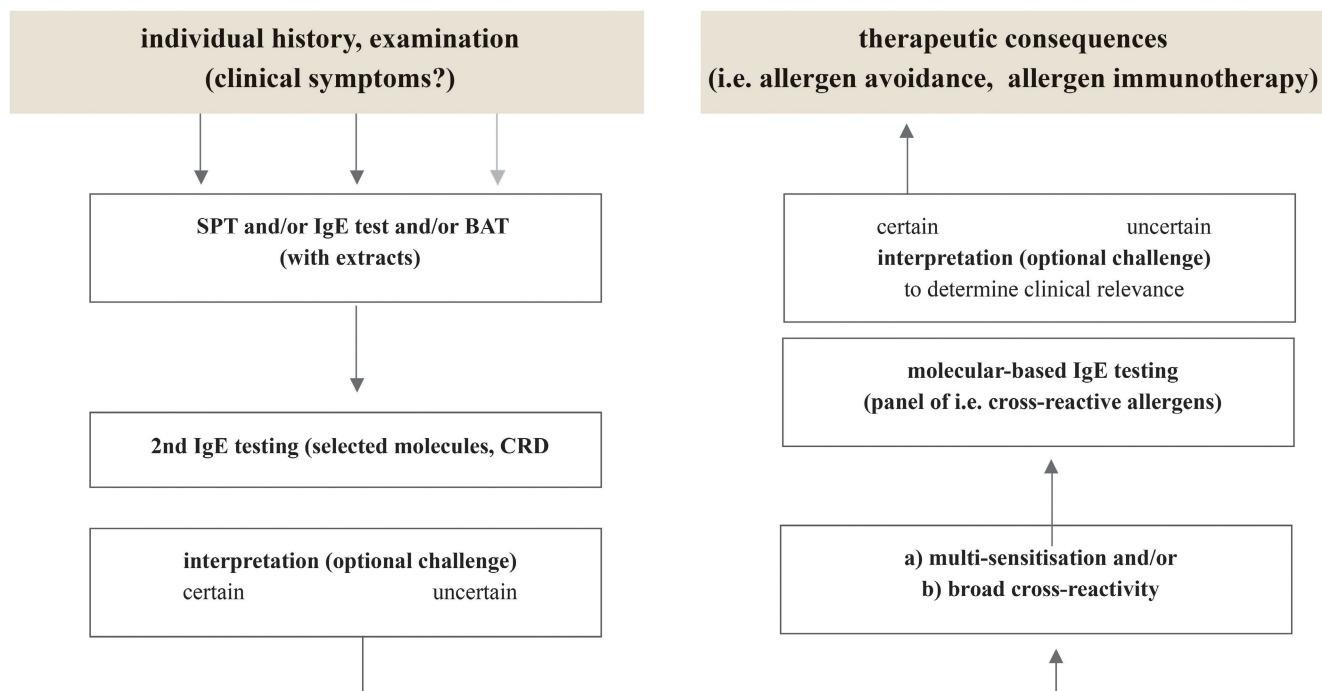


FIGURE 6 Combined diagnostic work-up with “top-down” and “bottom-up” approach. The diagnostic flow chart starts with the history, extract diagnostics, molecular diagnostics and subsequent application of extended molecular panels for further differentiation of the allergen-specific IgE repertoire. The approach, coined “U-shape,” has been proposed for complex cases.

The question remains if singleplex or multiplex testing should be applied:

- if possibly a large number of allergens from one family is involved, multiplex testing might carry some advantages.
- singleplex testing, however, offers an enhanced assay sensitivity, allowing the ultimate exclusion of IgE-mediated sensitization to the allergen in question if the allergen-specific IgE does not exceed the cut-off of 0.1 kU/l.
- therefore, the decision of singleplex or multiplex testing should consider the number of allergens to be tested and the preferred test sensitivity (very low or not as low).

Examples: seed storage proteins like 2S-albumins, 7S-globulins (vicillins), 11S-globulins (legumins). Note of caution: The number of storage proteins of different nuts, legumes and seeds that are available for diagnostics is still limited. This does not allow one to check for the presence of allergen-specific IgE to a full panel of these stable and risk-associated allergens. Therefore, allergen extracts are still needed, to indirectly get information on the potential relevance of the risk-associated storage proteins.

In conclusion, certain scenarios require a complete molecular diagnostic work-up after taking the history and performing focused extract- and molecule-based sensitization tests. This approach explores the degree and potential clinical relevance of further cross-reactivities to related molecules of a protein family. Singleplex assays would guarantee maximum assay sensitivity; multiplex assays would rather provide a broad panel of related, cross-reactive molecules for further definition of the IgE repertoire. The clinical relevance must be determined by the physician and not by the test, based on patient's history and outcome of challenge tests if needed.

6 – Molecular IgE sensitization profiles as biomarkers

Biomarkers are usually molecules that indicate physiological or pathologic phenomena. They reflect an objectively quantifiable measure of disease expression, severity and/or response to therapy. They can be beneficial in many different settings, especially in diagnostic processes and disease staging, identifying patients who will benefit from the treatment, monitoring disease trends, treatment efficacy and its side effects, predicting long-lasting protection, and thus improving acceptance and compliance. Along these lines, detection of molecular IgE sensitization profiles may function as biomarker in several settings as outlined below.

6.1 Sensitization to species-specific and cross-reactive molecules as diagnostic biomarkers

Grass pollen allergy represents a typical example for the use of allergen-specific IgE profiles as a biomarker, not only for an etiological confirmation of the presumptive diagnosis but also for the subsequent prescription of AIT. Patients with symptoms of allergic rhinitis during the grass pollen season and a positive SPT/IgE response to

grass pollen extracts are further investigated in order to detect serum IgE antibodies to Phl p 1, Phl p 2, Phl p 5, Phl p 7, Phl p 11, and Phl p 12. The identification of IgE antibodies towards one or more of the molecules Phl p 1, Phl p 2, Phl p 5, and/or Phl p 11 is then followed by the prescription of grass pollen-AIT. The presence of IgE to Phl p 12 (profilin), however, is followed by an investigation of a potential Oral Allergy Syndrome (OAS) including SPT/IgE assays with other pollen, fruit, or vegetable extracts. Furthermore, the identification of IgE to Phl p 7 may be indicative and alerts the doctor of a greater severity of disease including a higher risk of asthma (21). In addition, the presence of IgE to pan allergens such as Phl p 12 (profilin) and/or Phl p 7 (polcalcin) may provide an explanation for broad sensitization profiles obtained by extract-based skin test or sIgE testing.

Hymenoptera venom allergy is another excellent example in which sIgE to individual allergens serve as biomarker for genuine honey bee (Api m 1, Api m 3, Api m 4, Api m 10) or yellow jacket sensitization (Ves v 1, Ves v 5), while IgE to homologous allergens (such as the hyaluronidases Api m 2 and Ves v 2; the dipeptidyl peptidase IV Api m 5 and Ves v 3 and the vitellogenins Api m 12 and Ves v 6) indicate positive extract-based test results based on cross-reactivity (see chapters B20 and B21).

6.2 The impact of molecular assays on doctors' decisions

Providing a clear distinction between co-sensitization and cross-sensitization is an explicit advantage of CRD in allergology.^{80,81} A study with 651 Italian children suffering from moderate-to-severe pollen-related allergic rhinitis showed interesting results. No IgE to the respective major allergens was detected in significant proportions of patients with supposed clinically relevant sensitization (based on SPT) to mugwort (69%), Betulaceae (60%), pellitory (30%), olive (28%), cypress (15%), and grass (10%). IgE to profilins, polcalcins, or both could justify 37% of these SPT reactions. The SPT-based decision of prescribing specific immunotherapy and/or its composition was adapted in 277 (42%) or 315 (48%) of children according to the⁸² European or American approach, respectively, when taking into account the CRD results. This study reiterates the high and valuable role of CRD on the prescription and composition of AIT, particularly in geographical regions where polysensitization to airborne allergens is frequently observed. Another study, comprising 1263 Spanish patients and their sensitization patterns to the allergen molecules of grass and olive pollen had an analogous outcome. The entire study population had seasonal allergic rhinitis, with positive SPT results to grass and olive pollens. Of these patients, 922 (73%) would have been prescribed AIT with both grass and olive pollen, if following the traditional diagnostic approach. Incidentally, the AIT composition was modified for 56.8% of the patients after considering additional IgE results obtained by CRD.⁸³

6.3 Molecular IgE sensitization profiles as biomarkers predicting efficacy and safety

The heterogeneity of molecular sensitization profiles—A cross-sectional study with 176 Italian grass pollen allergic children

illustrated the vast amount of additional information that can be obtained with molecular diagnostic tests when compared to extract-based ones. All patients presented similar profiles when testing them for the allergenic extract of Timothy grass with conventional ELISA. They were all positive for Timothy grass, with the concentration ranging in amplitude. This homogeneity disappeared upon using a molecular assay, which uncovered a noteworthy diversity of responses. Overall, 39 different IgE sensitization profiles to grass pollen molecules were detected.⁸⁴ In another cross-sectional study, 82 different profiles were found among 1120 children. Both studies included monosensitized patients (in most cases to Phl p 1), as well as those sensitized to 5 of the examined 8 allergenic molecules. A correlation between the clinical phenotype and molecular sensitization profiles was observed. Specifically, Phl p 7 served as a reliable biomarker for asthma and possibly increased severity of seasonal allergic rhinitis, while Phl p 12 served as a biomarker of oral allergy syndrome (OAS).⁸⁵ In Germany, IgE results to *Phleum pratense* molecules were compared with nasal and conjunctival provocation tests in 101 adult patients with pollinosis. A significant heterogeneity of sensitization profiles, as well as a positive correlation between the number of recognized molecules and the likelihood of a positive provocation test result was observed. Interestingly, no match was observed between these IgE profiles and the composition of a previously published component-resolved specific AIT-containing Phl p 1, Phl p 2, Phl p 5a/b, and Phl p 6.⁸⁶ In a similar fashion, the individual sensitization profiles of 119 house dust mite allergic patients at 20 years of age from the German Multicenter Allergy Study cohort were extremely heterogenous. Of these, 27 subjects had a monomolecular profile, 50 subjects had an oligomolecular profile (responding to 2 to 4 molecules), and 42 subjects had positive IgE to ≥ 5 of the 12 tested molecules.²⁸ A similar picture emerged, when individual molecular sensitization profiles of 144 patients with honey bee venom allergy were analyzed. The characterization of IgE reactivity to Api m 1, Api m 2, Api m 3, Api m 4, Api m 5 and Api m 10 demonstrated 39 of 64 possible sensitization profiles, the ten most frequent profiles covering two thirds of the study population.⁸⁷ The heterogeneity of the AIT preparations—The standardization of allergic extracts requires consistent composition combined with stable potency related to clinical efficacy. Nevertheless, the Monograph on Allergen Products, a European regulation, allows a wide range of variation. Through measurement by IgE inhibition tests, it was uncovered that the percentage of individual allergenic molecules within an extract varies from 50% to 200%. A fairly simple allergen extract composed of only 3 major allergenic proteins, can therefore originate different batches with different allergen loads that range between very low and very high, including all intermediate possibilities. As an aftermath of these regulations, different manufacturers may provide allergen extracts of the same allergen source that differ greatly in their molecular composition and potency. The use of molecular assays that allow the comparative analysis of single allergens heterogeneity of AIT preparation has conclusively been demonstrated for a number of different allergen sources including birch and grass pollen, house dust mite, and insect venom preparations.^{88–90} Given this lack of standardization, occurrence of divergent SPT wheal reactions

for the same allergen species in the same patient elicited by different allergen extracts are not surprising.^{89,91} As for the *in vitro* settings, differences in IgE test results to extracts of the same allergen source may similarly be attributed to the composition of the extract.⁹²

Molecular sensitization profiles as biomarkers predicting AIT efficacy and safety—The use of allergenic molecules in various clinical studies aimed at monitoring changes in the specific antibody repertoire of patients receiving AIT has shown good outcomes.^{93,94} For instance, IgE sensitization profile before the start of AIT was proven to directly impact the efficacy of SLIT in patients with mite allergy. No efficacy of a house dust mite (HDM)-SLIT was observed among the total HDM-allergic population, including all IgE variabilities. Interestingly, a positive outcome is seen when analyzing only patients with IgE to Der p 1 or Der p 2. These results lead to believe that patients with stronger molecular spreading have a lower efficacy of AIT.^{84,95} However, specific studies designed to address the efficacy of molecular diagnosis driven AIT need to be performed since to date only post-hoc analysis have been performed with non-uniform results. While the results of Chen KW et al. suggest that the use of molecular assays is a promising approach for predicting and monitoring AIT efficacy, Arroabarren et al.⁹⁶ could not find a significant association between AIT efficacy and the HDM sensitization profile. A recent study on 24 HDM allergic patients who had received 1 year of treatment with Alutard SQ 510 concluded that the stratification of patients with HDM allergy according to molecular sensitization profiles and molecular monitoring of AIT-induced IgG responses may enhance the success of AIT.⁹⁷

The potential use of molecular sensitization profiles as biomarkers predicting AIT efficacy and safety has also been suggested in the field of Hymenoptera venom allergy. In patients with honey bee venom allergy sensitization to Api m 4 has been reported to be associated with an increased risk of systemic side effects during the induction phase of venom IT.⁹⁸ Furthermore, dominant IgE sensitization to the low abundance allergen Api m 10, which has been reported to be absent or underrepresented in certain venom preparations,^{99,100} has been associated with an increased risk of treatment failure in honey bee venom AIT.¹⁰¹ These recent studies emphasize that the use of molecular assays for the prediction and monitoring of AIT efficacy is a promising approach. However, more investigations in particular prospective studies are needed to confirm molecular IgE sensitization profiles as a predictive biomarker of efficacy.

7 – Allergenic molecules sorted by allergen sources and their relevance for clinical diagnostics

The use of molecular allergy diagnostics can only be successfully implemented in our daily routine when we have all the available information on the clinical relevance of each and every allergen at our fingertips. In an attempt to provide information on the clinically most relevant allergens, the authors of MAUG 2.0 provide a comprehensive list of allergenic molecules at the end of the e-book version at www.eaaci.org

A04 – Singleplex and multiplex Immunoassays

Robert G. Hamilton, Jörg Kleine-Tebbe

Highlights

- IgE antibody tests are run as singleplex (one), multi-allergen (<100) and multiplex (>100 allergen specificities) assays, all with particular design and performance features
- Allergen extracts remain the principal reagents for IgE assays; allergenic molecules supplement labile or missing allergens in extracts or are analyzed individually
- Allergenic molecules enhance the IgE assay's analytical sensitivity, and improve its analytical specificity by separating serological cross-reactivity from (genuine) sensitization to an allergen source.
- The relevance of positive allergen-specific IgE responses to extracts or molecules can only be determined by the physician based on the clinical context and not by the test itself.

1 – Introduction

The serological measurement of allergen-specific IgE antibodies provides the clinician with a measure of a patient's allergic sensitization profile. Two fundamental types of serological IgE antibody assays are performed in the clinical immunology laboratory. "Singleplex" or "monoplex" assays refer to laboratory methods in which one analyte is measured per analysis. "Multiplex" assays permit more than one analyte to be detected and quantified in a single assay analysis.¹⁰²

TABLE 1 Different formats and features of allergen-specific IgE-assays. "Classical" IgE assay format: Basis of most current singleplex and multiplex assays

	"classical" IgE assay format	"reverse" IgE assay format
1st assay step	allergen-specific IgE and other antibody isotypes (e.g., IgG) bind immobilized allergen reagent	Immobilized Anti-IgE ideally binds entire (total) IgE in the reaction vessel
2nd assay step	Labeled anti-IgE binds only allergen-specific IgE antibody	Labeled allergen reagent binds only allergen-specific IgE
Advantages (pro)	Detection of the entire allergen-specific IgE-repertoire (low and high affinity)	detection of allergen-specific IgE principally of higher affinity no competitive inhibition through allergen-specific immunoglobulins other than IgE, (i.e. IgG)
Limitations (con)	competitive inhibition by allergen-specific immunoglobulins other than IgE, (i.e. IgG antibody after subcutaneous immunotherapy or natural exposure)	large amounts of anti-IgE are needed for sera with high total IgE levels biased results (lower values) in samples with a low specific to total IgE-ratio. ¹⁰⁶
Potential use in multiplex assay formats	miconization of binding chemistry and limited amounts of allergen reagents required	less useful due to the need of multiple labeled allergens (to be put into one reaction vessel)
References	Ekins ¹⁰³	Ricci et al. ¹⁰⁴ ; Petersen et al. ¹⁰⁵

This report examines the technology, performance, and application of singleplex and multiplex IgE antibody assays that utilize allergen extracts, allergenic molecules (components) and select epitopes on allergenic molecules in the diagnosis and subsequent management of human allergic disease.

ImmunoChemistry Design Considerations

Two fundamental immunoassay chemistries that have been referred to as "classical" or "reverse" assay formats have been used to detect IgE antibody (Table 1). The noncompetitive, heterogeneous (separation of free and bound), immunometric (labeled antibody) immunoassay¹⁰³ that employs allergen immobilized on a solid phase "allergosorbent" to bind specific antibodies of all isotypes from serum is the design that has endured in both singleplex and multiplex assays that are used in clinical laboratories (Figure 7). Following a buffer wash to separate free and bound human antibody, radionuclide-, enzyme- or fluorescence-labeled anti-human IgE is added to detect IgE antibodies that have bound to immobilized allergen. The magnitude of the response (counts per minute-radioactivity, optical density, chemiluminescence, or fluorescence) after the final buffer wash is proportional to the quantity of allergen-specific IgE antibody in the original test serum.

2 – Reverse IgE format: basis of certain singleplex assays

A reverse or capture anti-IgE assay design uses a second step liquid-phase allergen to detect allergen-specific IgE antibody. In this assay (Figure 7 – bottom right panel), all IgE (in theory) is initially captured from serum by a paramagnetic particle solid-phase anti-IgE

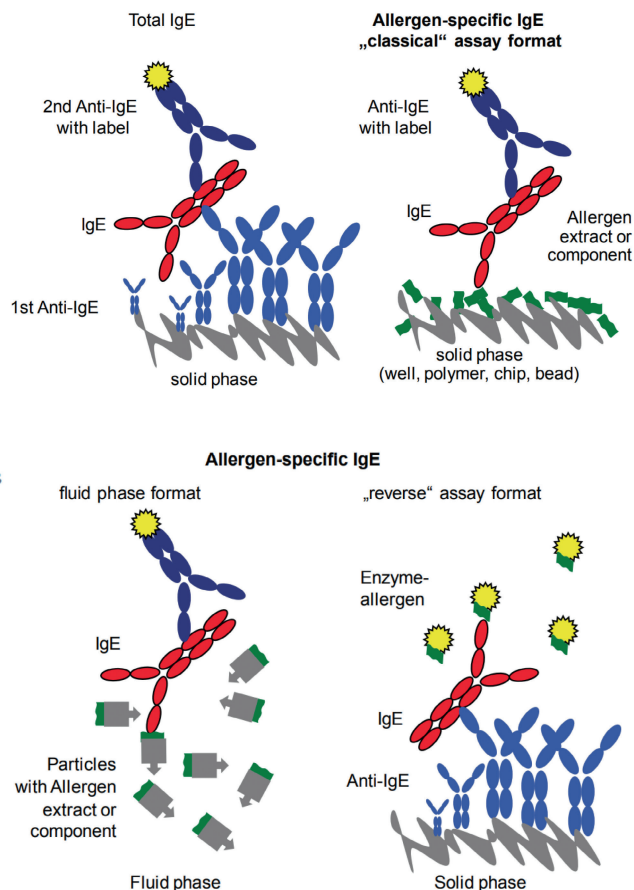


FIGURE 7 Top panel: General principle of “classical” solid phase IgE assay formats for total and allergen-specific IgE quantification; Bottom panel: General principle of the fluid phase “classical” (left) and “reverse” IgE assay format (right) for allergen-specific IgE quantification

in molar excess to the amount of IgE in most test sera. Following the capture of human IgE, allergen-specific IgE antibody is detected with limited quantities of labeled allergen. The reverse phase assay format has been used for IgE antibody quantitation in the ADVIA Centaur.^{104,105} The principal advantage of the reverse phase assay over the classical allergosorbent-based singleplex assay is its tendency to measure principally high affinity IgE antibody that is assumed to be “more” clinically relevant (Table 1). By contrast, assays that use molar excess amounts of allergen that have been immobilized on an allergosorbent tend to more broadly detect both low- and high-affinity IgE antibody. The reverse assay format also addresses the concern of competitive inhibition caused by allergen-specific antibodies of non-IgE isotypes origin such as IgG anti-allergen that can achieve microgram per ml levels in sera from individuals receiving immunotherapy. The reverse assay format is, however, less amenable to use in multiplex assays where multiple labeled allergens would have to be added to the same reaction vessel. It suffers from a requirement for large amounts of anti-IgE capture antibody to insure the binding of all IgE molecules from the test serum. The reverse assay design can also show a major bias because its performance depends on the fraction of the total IgE that is specific for the allergen

of interest. These assay design constraints have resulted in the disappearance of the reverse assay format from use in clinical laboratories in the USA and elsewhere.

3 – Heterologous calibration based on total IgE for singleplex allergen-specific IgE systems

Consensus has been established that a single generic total serum IgE calibration system is the only workable calibration strategy for use in clinical IgE antibody assays.¹⁰² It allows interpolation of IgE antibody results from any of the hundreds of allergen specificities as long as the total serum IgE and allergen-specific IgE portions of the assay dilute out in parallel with each other. The total serum IgE “heterologous” calibration system that is used in all regulatory cleared singleplex assays is traceable to the World Health Organization’s recently depleted 75/502 and currently used third 11/234 human IgE Reference Preparations.¹⁰⁶ This calibration system allows interpolation of IgE antibody results from a limit of quantitation of 0.1 kU/L to 100 kU/L levels of IgE antibody. While rarely performed in clinical testing, serum levels of IgE antibody greater than 100 kU/L can be accurately determined by re-analysis of the serum at a dilution and subsequent mathematical correction for the dilution factor. The alternative to the total serum IgE-based heterologous interpolation scheme is the use of individual allergen-specific calibrations, one for each allergen specificity. Early attempts involving the use of this approach exposed its major limitation, which involved a demand for liter quantities of IgE-positive sera for each specificity.¹⁰⁷ This made the multiple specific IgE antibody calibration strategy impractical, especially since there are no internationally recognized polyclonal human IgE antibody reference preparations.

4 – Multi-allergen versus multiplex assays

A true multiplex antibody assay allows many specificities of a single antibody isotype (e.g., IgE) to be individually detected and semi-quantified in a single analysis.¹⁰² This assay design can be distinguished from a “multi-allergen” screening assay in which many allergen specificities from a common group (aeroallergens or food allergens) are mixed and immobilized together as extracts or components on a single solid phase. This multi-allergen reagent is typically used in a singleplex assay format to simultaneously detect specific IgE to multiple antibody specificities in a single reaction. A single qualitative (positive or negative) result is generated for each specimen based on a positive/negative cutpoint. However, the actual allergen specificities that produce a positive IgE antibody response in the multi-allergen screen cannot be definitively identified by the requesting physician without further analysis using additional singleplex assay analyses, one for each of the individual allergen specificities on the multi-allergosorbent. One widely used multi-aeroallergen screening assay measures IgE antibody to 10 or more aeroallergen extracts.¹⁰⁸ The allergen specificities immobilized on

a single solid phase are carefully selected because they are known to be unique or cross-reactive with the major specificities that induce the majority of aeroallergen-related allergic symptoms. Due to its high negative predictive value, this particular multi-aeroallergen assay serves as a cost-effective screen to rule out allergic sensitization in an individual with a questionable respiratory allergy history and to define the atopic status of individuals enrolling in asthma studies.¹⁰⁹

5 – Heterogeneity in IgE antibody measurements from different assay types and manufacturers

In most multiplex assays, the small quantities of the individual allergens bound to a solid phase contrast with the higher IgE antibody-binding capacity present on individual hydrophilic polymer and bead-based allergosorbents that are used clinically. Law of Mass Action constraints cause these assays to detect different distributions of allergen-specific IgE antibody in any given serum. The amount of antibody detected in the assay is dependent on multiple factors including the IgE antibody's concentration, affinity, epitope specificity, IgE-specific activity (specific to total IgE ratio)¹¹⁰ and level of non-IgE antibody specific for the allergen.¹⁰² The more antigen-limiting multiplex allergosorbents tend to bind more allergen-specific IgE antibody when it is higher in concentration, has a higher affinity, the serum has a higher specific IgE antibody to total IgE ratio and a lower concentration of competing allergen-specific non-IgE (typically IgG) antibody. These mass action considerations have important assay performance consequences, especially when analyzing sera with nanogram quantities of IgE antibody that are present with high microgram/ml levels of allergen-specific IgG antibody.¹¹¹ Such high IgG anti-allergen levels can result from inadvertent natural exposure to high levels of allergen or hyper-immunization through allergen immunotherapy. IgG antibody competes with the lower nanogram/ml levels of IgE antibody for limited allergen binding sites on the multiplex chip allergosorbent.^{111,112} This constraint has been cited as an advantage of the multiplex assay format in that its lower level of detected allergen-specific IgE antibody in the presence of high allergen-specific IgG may more closely reflect the true biological consequence of IgG interference with allergen binding to IgE attached to effector cells.

6 – Advantages and limitations of multiplex assays

Table 2 summarizes commonly cited performance and assay design advantages and limitations of a multiplex assay in comparison with the singleplex assay. Multiplex assays are attractive because they tend to have a shorter turn-around time for result generation. They tend to use less specimen volume by simultaneously testing multiple IgE antibody specificities in a small surface area on the solid phase. Their assay design tends to be simpler, with fewer reagents and less technician time that reduces overall costs. Multiplex assays,

especially in a hand-held cassette format, are attractive for use as point of care tests.^{113,114} These advantages are offset by the multiplex assays' potentially higher limit of quantitation, reduced ability to provide quantitative levels of antibody for each respective IgE specificity, and an increased challenge in optimizing the assay, which involves simultaneous quality control of many immobilized allergens. There is the potential for greater inter-lot variability as a result of the need to balance multiple reagents in different spots on a single allergosorbent. The fixed allergen menus of the multiplex assay encourages the testing of IgE antibody for unwanted or unnecessary specificities. Finally, there can be additional expense associated with the need to purchase new equipment to perform a multiplex assay.

7 – Current Assay Technology

Common IgE assay systems based on singleplex technology

Many versions of the “classical” IgE assay format have been cleared by governmental regulators over the years. Worldwide, three singleplex autoanalyzers that use the “classical” allergosorbent design dominate the current clinical laboratory market. These are the ImmunoCAP Specific IgE test (Thermo Fisher Scientific/Phadia); Immulite (Siemens Healthcare Diagnostics) and the Noveos (Hycor Biomedical). In Europe, there are additional assays with the EU mark that use a similar assay design but that are not available worldwide for use in clinical laboratories. The performance characteristics of the three predominant singleplex autoanalyzers have been assessed using masked patient specimens and inter-laboratory proficiency data. All three singleplex autoanalyzers use an analogous total IgE calibration curve. They display good precision, reproducibility and they report down to the same 0.1 kU/L limit of quantitation. Multiple studies have confirmed, however, that they report different levels of IgE antibody for any given specificity, which indicates that they detect different distributions of allergen-specific IgE antibody most probably due to the use of different allergen-containing reagents and possibly a result of slightly different procedures for assay calibration and data computation.

8 – Introduction of single molecules (components) into singleplex and multiplex assays

The single most important scientific advance to impact on the use of multiplex assays in the diagnostic allergy laboratory has been the identification since 2000 and purification of allergenic components from principal aero-, food and venom allergens as discussed extensively throughout this book. Molecular biology techniques have been employed to generate recombinant forms of many of the allergens and others are isolated from extracted native sources using various purification procedures. Allergen libraries have been created as illustrated by the food allergen library from the EuroPrevall project that has established rigorous verification and purity requirements for allergenic molecules.¹¹⁵ Well-characterized allergenic

TABLE 2 Advantages and limitations of singleplex and multiplex assay technology for allergen-specific IgE testing that utilizes allergenic molecules (components)

	Singleplex IgE assay format	Multiplex IgE assay format
Performance Related Advantages (pro)	<ul style="list-style-type: none"> * Increased assay analytical sensitivity (lower Limit of Quantitation, LoQ) * Potentially more precise quantification and precision, facilitating comparisons between different allergen reagents (extracts versus molecules) * More established internal and external quality control measures (proficiency testing) 	<ul style="list-style-type: none"> * Increased speed of analysis and reduced result turn-around time * Conservation of sample volume facilitating pediatric testing
Assay Design and Cost Related Advantages (pro)	<ul style="list-style-type: none"> * Traceable of allergen-specific IgE values to a total human IgE International Reference Preparation * Similar units for total IgE and allergen-specific IgE due to heterologous calibration (permits calculation of allergen-specific IgE/total IgE-ratio) * Global availability in many countries * In case of limited number of samples more cost efficient * Minimizes unneeded testing 	<ul style="list-style-type: none"> * Greater simplicity * Reduced cost due to fewer required reagents * Reduced technician intervention * Optimal design applications for point of care tests
Performance Limitations (con)	<ul style="list-style-type: none"> More costly due to increased need for reagents to evaluate polysensitized patients More technical intervention Limited answers in case of few samples per subject Expensive in case of large scale screening (i.e. multi-sensitized subjects) 	<ul style="list-style-type: none"> * Potentially lower analytical sensitivity for each analyte specificity measured (higher limit of detection, LoD) * Reduced ability to accurately quantify each IgE antibody * Encouragement of abusive testing which involves the measurement of unwanted or unneeded IgE antibody specificities
Assay Design and Cost Related Limitations (con)	<ul style="list-style-type: none"> * More serum required, particularly in case of many samples * Potentially slower analysis * Likely more sophisticated assay format 	<ul style="list-style-type: none"> * Less global availability * Cost of the new instrumentation and reagents * Greater challenge in managing different levels of non-specific binding * Enhanced challenges in optimizing, balancing and standardizing assay reagents and assay quality control * Potential greater inter-lot variability

components from cow's and goat's milk, chicken egg, fish, shrimp, hazelnut, peanut, celery and fruits from the *Rosaceae* family (apple and peach) have been produced. Documentation of these allergenic components has involved extensive analytical, immunochemical and 3-dimensional structural analyses.

The availability of unlimited quantities of the molecular allergens has allowed multiplex chip microarray based assay methods to be used for rapid simultaneous evaluation of human sera for IgE antibodies to multiple allergen specificities. The most important illustration of technology transition from singleplex to multiplex assays has involved the chip-based multiplex IgE antibody assay initially reported by Hiller et al.¹¹⁶ The original chip-based microarray utilized 49 purified allergen molecules, which were covalently immobilized in fixed microdot arrays on a preactivated glass slide. IgE antibody profiles of allergic individuals were evaluated to disease-causing

allergens in a single multiplex analysis using 30 microliters of undiluted serum. With this report, serious clinical application of both allergenic components and multiplex assay methods became available to evaluate individuals for allergic disease. From this initial proof of concept, the repertoire of allergens has increased and the assays' lower limit of quantitation and reproducibility have continued to improve. The commercially available version of this assay is the immune solid phase allergen chip or ImmunoCAP ISAC (Thermo Fisher Scientific/Phadia), which requires 30 microliters of serum to detect IgE antibody to 112 individual allergenic molecules that are in a static or planar array in triplicate on a glass slide.¹¹⁷⁻¹¹⁹

The ImmunoCAP ISAC reports IgE antibody levels in ISU units, which are considered semi-quantitative.¹¹⁸ A good correlation exists between the summed IgE anti-cow's milk components levels (Bos d 4,5,6,8 and lactoferrin, $r^2 = 0.66$) as measured in 44 sera from

clinically milk allergic individuals by the singleplex ImmunoCAP Specific IgE test (x-axis) and multiplex ImmunoCAP ISAC (y axis).¹²⁰ (Figure 8 – top panel). The correlation remains impressive when one compares the individual IgE anti-cow's milk components (Bos d 4,5,6,8 and lactoferrin, $r^2 = 0.77$) as measured in the same sera by ImmunoCAP Specific IgE and ImmunoCAP ISAC tests (Figure 8 – bottom panel). The lower analytical sensitivity of the ImmunoCAP ISAC test, however, depends on the allergen in question^{118–120} and is evident with some strongly positive IgE antibody levels as detected in the ImmunoCAP Specific IgE test that are undetectable in the same sera when analyzed in the ImmunoCAP ISAC test.

In 2014, a research version of the ImmunoCAP ISAC called the “Mechanisms for the Development of ALLergy” or MeDALL allergen chip was produced with 170 allergen molecules to more broadly study IgE and IgG antibody development in children.¹¹² Using defined concentrations of chimeric IgE and IgG antibodies specific for Bet v 1, the study demonstrated that the simultaneous presence of IgG blocking antibodies can effectively inhibit IgE antibody binding to Bet v 1 allergen that has been immobilized onto the multiplex chip. By contrast, the same levels of IgG anti-Bet v1 produce minimal competitive interference in the more antigen laden singleplex ImmunoCAP Specific IgE test. The authors suggest that the inhibition of IgE binding by IgG antibodies of the same specificity to limited allergen immobilized on the chip may more closely reflect biological responses under conditions of natural allergen exposure. However, the clinical relevance of this inhibition needs further investigation. The smaller amount of allergen on the chip also reduces the working range of the IgE antibody assay in comparison to the singleplex ImmunoCAP Specific IgE test, whose allergosorbent has 10,000,000 times more allergen coupled.¹¹²

The Allergy Explorer (ALEX²) (Macro-Array Diagnostics, Wien, Austria) employs nearly 300 allergen extracts (n=117) and recombinant or purified native molecules (n=178) that are spotted on a solid phase by the use of nanoparticles. Quan et al.¹²¹ evaluated the clinical and technical performance of the ALEX² against the ImmunoCAP ISAC-112 microarray and the ImmunoCAP Specific IgE singleplex assay. Repeatability and inter-assay, inter-batch, and inter-laboratory reproducibility were evaluated using sera from clinically allergic and nonatopic patients.

EUROLINE (Euroimmun, Lübeck, Germany) produces a multiplex IgE antibody test that is immunoblot-based and widely used in Europe. Di Fraia et al.¹²² studied the multi-parameter semi-quantitative immunoblot molecular “Pollen Test” produced by EUROLINE that is designed to detect IgE antibodies to pollen extracts and molecules, which are clinically relevant to patients in Southern Europe. The test strip consists of nine membrane chips with different allergen extracts or components that are immobilized in parallel lines, which are mounted on a carrier foil. Allergen extracts and allergenic molecules from birch, olive tree, cypressus, Bermuda grass, Timothy grass, mugwort, alternaria and cross-reactive carbohydrate determinant are immobilized. The semi-quantitative response data (range 1–6) are measured as a band intensity and they provide an estimate of IgE antibody concentration.

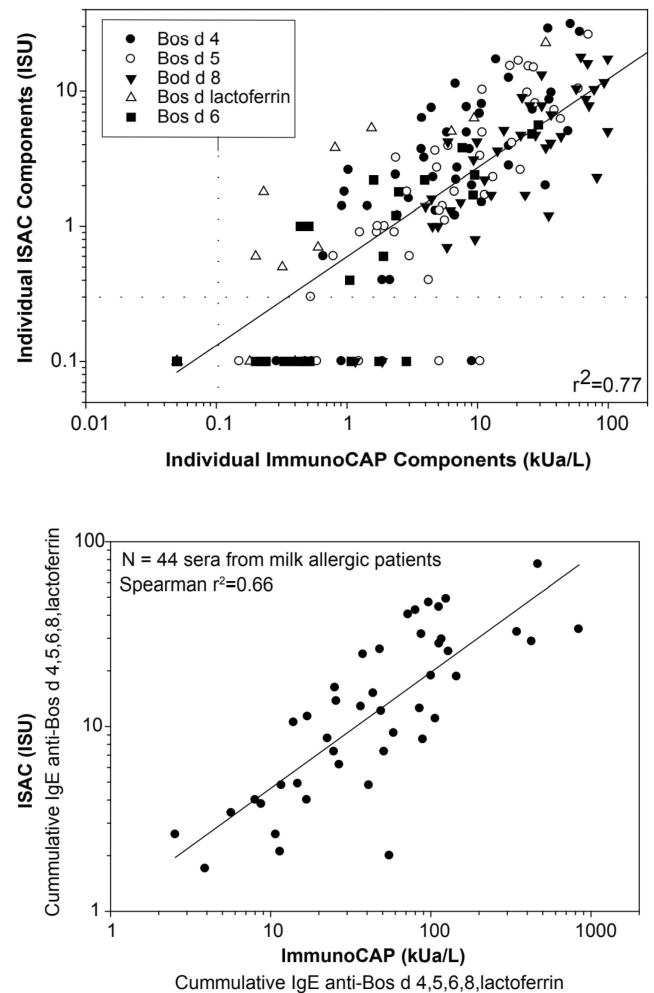


FIGURE 8 Left panel: correlation between the summed IgE anticow's milk (*Bos domesticus* [Bos d]) components as measured in the ImmunoCAP and ISAC (Bos d 4: alpha lactalbumin; Bos d 5: beta lactoglobulin; Bos d 6 bovine serum albumin; Bos d 8: casein; Bos d lactoferrin). Right panel: Correlation between the individual IgE anti-cow's milk (*Bos domesticus* [Bos d]) components as measured in the ImmunoCAP and ISAC (Bos d 4: alpha lactalbumin; Bos d 5: beta lactoglobulin; Bos d 6 bovine serum albumin; Bos d 8: casein; Bos d lactoferrin) components. The dashed lines indicate the positive/ negative cut-off for each assay: ImmunoCAP 0.1kU/L; ImmunoCAP ISAC: 0.3 ISU. Reproduced with permission from [120]

The ImmunoCAP ISAC, ALEX,² and Euroline are examples of diagnostic assays that require the physician to compromise between a targeted molecular singleplex IgE antibody assay strategy where individual allergen specificities are selected based on the patient's history, and use of a rigid allergen microarray panels, which contain a prescribed number of allergen specificities, some of which will not be relevant to a patient. The testing of unnecessary allergen specificities in a fixed menu based multiplex assay reduces the test's benefit to cost ratio. A recent literature review-based examination of these and other pro/con issues related to IgE antibody microarray assays is provided by Keshavarz et al.¹²³ As outlined in (Table 3), the authors emphasize the strengths of the microarray

TABLE 3 Potential criteria for assessing assay improvement of sensitization tests following the replacement of allergen extracts with allergenic molecules

Exemples (allergen source, allergen carrier)	Increased analytic sensitivity	Increased analytical specificity/selectivity	Cross-reactive allergens	Species/family-specific major allergens
cat		Fel d 2	Fel d 2	Fel d 1
hazelnut	Cor a 1 (Bet v 1-homologue)	Cor a 14 (2S albumin), Cor a 9 (11S globulin) Cor a 8 (LTP, mediterranean)		
kiwi	Act d 8 (Bet v 1-homologue)		Act d 8 (Bet v 1-homologue)	
peach	Pru p 1 (Bet v 1-homologue)	Pru p 3 (LTP, marker, mediterranean)	Pru p 1 (Bet v 1-homologue), Pru p 4 (Profilin)	
peanut	Ara h 10, Ara h 11 (oleosins)	Ara h 1 (7S globulin) Ara h 2 (2S albumin) Ara h 3 (11S globulin) Ara h 6/7 (2S albumin) Ara h 9 (LTP, mediterranean)	Ara h 8 (Bet v 1-homologue), Ara h 5*	
soy	Gly m 4 (Bet v 1-homologue)	Gly m 5, Gly m 6		
wheat	Tri a 19 (omega-5-gliadin)			
meat	alpha-GAL	alpha-GAL		
honeybee venom	Api m 3, Api m 4, Api m 10	Api m 1, Api m 3, Api m 4, Api m 10		Api m 1, Api m 3, Api m 4, Api m 10
yellow jacket venom	Ves v 5	Ves v 1, Ves v 5		Ves v 1, Ves v 5
birch (hazel, alder, birch pollen) and beech trees (beech, oak pollen)		Bet v 1	Bet v 2*, Bet v 4**	Bet v 1
oleaceae (ash, olive pollen)		Ole e 1	Ole e 2*, Ole e 3**, Ole e 7	Ole e 1
poaceae (pollen from moderate climate grasses)		Phl p 1, Phl p 5	Phl p 12*, Phl p 7**	Phl p 1, Phl p 5
mugwort pollen		Art v 1	Art v 4*, Art v 5**	Art v 1
ragweed pollen		Amb a 1	Amb a 8*, Amb a 10**	Amb a 1

technology that reside in its ability to detect IgE to a large number of allergens, simultaneously in a single test, using a small amount of patient serum. This is counter-balanced against a higher relative cost per allergen specificity, a generally lower analytical sensitivity than single-plex assays, semi-quantitative results, and difficulties with data interpretation and managing simultaneous results involving 100s of allergen specificities. They conclude that IgE microarray assays are currently invaluable research tools and increasingly used in the clinical practice of allergy, particularly in Europe. Artificial intelligence algorithms will be increasingly used by clinicians to aid them in digesting the complex inter-relationship of allergen families, cross-reactivities, and unique signature specificities that are provided by the multi-allergen IgE antibody-based arrays.

9 – Additional multiplex IgE assays used in research or in development

While the ImmunoCAP ISAC test, ALEX² and Euroline have been highlighted for their use with purified recombinant and native allergenic molecules, other assays use a combination of allergen extracts

and molecules immobilized in chip microarrays using different multiplex assay configurations.

- A In 2015, Williams et al.¹²⁴ reported comparative testing of ImmunoCAP ISAC test, ImmunoCAP Specific IgE test and puncture skin testing with a chip-based multiplex autoanalyzer called the MicrotestDx. In contrast to the ImmunoCAP ISAC test, it uses 100 microliters of serum and employs a limited number of 19 allergen extracts and 16 allergenic molecules covering a total of 26 aero- and food-allergen specificities that are covalently immobilized onto a precoated chip in triplicate. This is a scaled down version of a proof of concept assay that used 95 allergen extracts and 8 recombinant proteins, which were immobilized on aldehyde-activated glass microscope slides. These initial IgE antibody comparative data while initially encouraging have not yielded a viable assay to date to compete with the ImmunoCAP ISAC test and ALEX.²
- B Wiltshire et al. spotted a small number of allergen extracts on activated microarray slides and used an interesting rolling DNA circle amplification strategy to detect IgE antibody bound to immobilized allergen.¹²⁵ Feyzkhanova et al.¹²⁶ photo-induced

copolymerization of 21 allergens (15 extracts and 6 molecular allergens) into a hydrogel covered chip and used 60 microliters of serum to perform IgE antibody microarray analyses. Renault et al.¹²⁷ reported a microarray assay in which 350 defatted and extracted foods were imprinted on slides (4800 dots per slide) and human IgG, IgA, IgM and IgE antibodies were simultaneously detected in serum using a 4 laser scanner. Joshi et al.¹²⁸ reported on an ultrasensitive carbohydrate-peptide surface plasmon resonance imaging microarray in which they immobilized peptide and xylosyl glycoside of Ara h 2 onto carboxylated gold slides and amplified the response with 1 micron diameter magnetic beads coated with ~60,000 polyclonal anti-IgE molecules. None of these proof-of-concept assays have been commercialized into viable assays for research and clinical use. The use of novel imaging systems and allergen extracts bound to chips raise theoretical concerns about the analytical sensitivity and specificity of the assays and whether the limited binding capacity of microdot surface on an activated glass or silicon chip can immobilize sufficient molar concentrations and all relevant allergen in an extracted protein mixture to quantitatively bind IgE antibody in the presence of other antibody isotypes.

- C Alternative multiplex technologies are capable of detecting IgE antibody in human serum. The Luminex bead based suspension array assay uses fluorescent microspheres that are coupled with allergen, one specificity per bead type. Each bead type emits a different internal fluorescence that allows them to be distinguished from each other in a flow cytometer when they are mixed together. Each well of a microtiter plate is loaded with a mixture of bead types (50 microliters; 2000 beads) and serum (50 microliters at 1:4). Following an incubation and wash, bound IgE antibody is detected with biotinylated anti-IgE and avidin-phycoerythrin. The fluorescence intensity on the surface of the individual bead types is quantified and interpolated from a (fluorescent intensity vs total serum IgE) calibration curve. This assay is provided as a commercial laboratory developed test service by Indoor Biotechnologies (Charlottesville, VA, USA) to measure IgE antibody specific for a panel of 6 molecular aeroallergens from dust mites (Der p 1, Der p 2), cat dander (Fel d 1), dog dander (Can f 1), birch tree pollen (Bet v 1) and Timothy grass pollen (Phl p 5)¹²⁹.
- D A different multi-array approach has been employed by Meso-Scale Discovery (MSD).¹³⁰ Initially, α -lactalbumin, β -lactoglobulin A/B, α - β - κ -casein, lactoferrin and BSA proteins were individually biodotted onto separate spots in NPT 9-spot plates. Each spot within the same reaction well permitted a separate antibody specificity to bind. Following reaction with milk allergic sera, bound IgE antibody was detected with Sulfo-Tag-labeled anti-human IgE antibody. Bound labeled antibody when exposed to an electrical pulse generated chemiluminescence through an oxidation-reduction reaction that was measured in an automated reader. Response levels were interpolated from a calibration curve into IgE antibody units. In 2021, Millen et al.¹³¹ validated a MSD multiplex immunoassay against the skin prick test and ImmunoCAP assay for respiratory allergens (Dpt, Cat, dog; rye timothy grass; mugwort and birch pollen, Cladosporium, Aspergillus, Alternaria, and a mixture of animals, fungi, grasses, weeds, trees, house dust mites and mixed nuts). They used sera from adult patients with allergic rhinitis. Pearson correlations and Bland-Altman analysis showed high comparability of the MSD multiplex immunoassay with the prick skin test and the ImmunoCAP Specific IgE assay, except for house dust mite. The reproducibility of the MSD multiplex immunoassay as assessed for intra- and interassay reproducibility and biological variability between different sampling periods, showed significantly high correlations. This study shows proof of concept; however, MSD presently offers only a total serum IgE assay and does not commercially produce allergen-containing reagents for specific IgE antibody quantification.
- E Chinnasamy et al. investigated a vertical flow allergen microarray assay with 10 purified allergenic molecules at 3 concentrations that were immobilized on 0.1 μ m pore size nitrocellulose membranes.¹³² Bound IgE antibodies from human sera were detected with gold nanoparticle bound anti-IgE using a colorimetric read-out. Its precision and relative concordance with the singleplex ImmunoCAP Specific IgE were encouraging. However, to apply this vertical flow strategy, additional verification analyses were needed to validate the technique. Unfortunately, further direct comparison studies with clinical specimens that had been analyzed in parallel with established single and multiplex IgE assays were not performed and this assay format was therefore not pursued further.
- F A novel nanotechnology biosensor point of care test has been developed by Abionic (Epalinges, Switzerland) in which serum is mixed with fluorescently labeled anti-IgE and the mixture added to a capsule containing 10 allergenic molecules coupled to a biosensor surface. Capillary action drives allergen-specific IgE to bind to immobilized allergen and fluorescent molecular complexes are then optically measured by the abioSCOPE reading unit. The fluorescent response is finally translated to an IgE antibody dose. This is graphically overviewed by Chapman et al.⁷¹ The assay remains available but needs regulatory clearance for clinical use.
- G The PROTIA™ Allergy-Q 64 Atopy (Proteometech, Seoul, Korea) has been evaluated in comparison to the ImmunoCAP Specific IgE test using the sera of 125 Korean allergic patients. The agreement for the 10 allergen components tested was > 88% for group 1 house dust mite (HDM) allergen, 100%; group 2 HDM allergen, 94.6%; Bet v 1, 97.4%; Fel d 1, 90.5%; Que a 1, 89.2%; α -lactalbumin, 96%; β -lactoglobulin, 88%; casein, 88%; ω -5 gliadin, 96%; and 100% for α -Gal.¹³³ More extensive cross-validation is needed to elevate this procedure to clinical use.
- H McKenzie et al.¹³⁴ has developed a novel flow cytometric assay called the CytoBas that uses fluorescent protein tetramers for direct staining of IgE antibodies on blood basophils that are then detected by flow cytometry. In a proof of concept study, recombinant forms of grass Lol p 1 and Lol p 5 and honeybee venom Api m 1 were produced, biotinylated, and tetramerized with

streptavidin. These-fluorochrome conjugates were then incubated with whole blood samples from grass and bee venom allergic patients and analyzed by flow cytometry for basophil binding and activation. Direct fluorescence staining of Api m 1 and Lol p 1 tetramers had greater positive predictive values than basophil activation and the staining intensities of allergen tetramers correlated with allergen-specific IgE levels in serum.

10 – Evolution from allergen molecules to allergen epitopes.

Diagnostically relevant allergenic epitopes have been identified by epitope mapping using sera from sensitized and (in some cases) clinically allergic individuals. These sera contain IgE antibody to restricted regions on particular allergens. Immunodominant peptides have been identified from a library of overlapping continuous short peptides by IgE binding to synthetically produced allergen peptide fragments spotted on membranes, or plated in microarray chip or bead-based immunoassays. While these methods have been successful in identifying immunodominant peptides that can be associated with a greater likelihood of a persistent allergy or a severe reaction, the process of their identification is laborious and expensive. Monaco et al.¹³⁵ have developed a programmable phage display based procedure that can evaluate the binding of allergen-specific IgE and IgG antibodies to a library of ~2000 allergenic proteins plated as overlapping 56 amino acid peptides using a single multiplex reaction. This procedure reduces cost and provides high-throughput in the identification of novel allergenic epitopes that have potential predictive clinical utility. They use of an oligonucleotide library synthesis to encode a database of allergenic peptide sequences for display on T7 bacteriophages. This AllerScan library permits high throughput DNA sequencing and is used to identify thousands of IgE and IgG antibodies that bind to hundreds of distinct peptides. In their proof of concept study, they identified IgE antibodies that bind to wheat specific linear peptides using sera from wheat sensitized and allergic (or nonallergic control) subjects. From their work, a particular allergenic protein (purothionin) was identified that has promise in distinguishing sensitized allergic subjects who manifest objective clinical reactions from sensitized but nonallergic subjects who can readily consume wheat products.

In the diagnosis of food allergies, allergen epitope-based assays have been developed with the goal of identifying sensitization patterns that could reduce the need for definitive placebo-controlled food challenges that require significant resources, time and risk. These assays are based on early work involving cluster analysis of cow's milk and peanut linear and conformational allergen epitopes. Using microarray peptide immunoassays, IgE and IgG4 antibody patterns were identified that discriminated between food-sensitized individuals who were able to pass from those who failed an oral food challenge. Interpatient heterogeneity provided the promise of enhancing the diagnostic predictability of food allergen-specific IgE antibody analyses.^{136–138} In a 2018 study of milk allergic patients

receiving oral milk immunotherapy with and without omalizumab (Anti-IgE) treatment, IgE and IgG4 antibodies to 66 sequential epitopes on 5 cow's milk proteins using a bead-based Luminex assay showed that certain baseline antibody profiles to 6 IgE-binding epitopes appeared more predictive of sustained unresponsiveness to milk exposure. than comparable antibody responses to their associated allergenic cows' milk components. Subsequently, the presumed protective effects of epitope-specific IgG1/4, IgA, and IgD immune responses in relation to epitope-specific IgE were investigated in individuals with a history of chicken egg allergy. Collectively higher ovomucoid epitope-specific IgE and IgD together with lower IgA and IgG antibody levels as measured with a bead-based epitope Luminex assay compared with atopic controls were shown to be important contributors to the pathogenesis of egg allergy^{139,140} (49-50). In the most definitive study to date, predictive performance of a peanut bead-based epitope Luminex assay was evaluated using sera from subjects in the noninterventional arm of the LEAP trial, CoFAR2, and POISED clinical studies that used a double-blind placebo-controlled food challenge to document peanut allergy status. Diagnostic performance of IgE antibody measurements to two Ara h 2 sequential linear epitopes were superior to skin prick testing and peanut extract and component specific IgE test results in correctly diagnosing the allergic versus not-allergic status of the sensitized study subjects (92% diagnostic sensitivity and 94% diagnostic specificity)¹⁴¹ These studies confirm that for select food allergen specificities, IgE antibody measurements at the allergenic epitope level are becoming increasingly diagnostically important in the management of food allergic patients.

11 – Rationale for the introduction of allergenic molecules and epitopes into clinical IgE antibody assays

The use of single allergens (molecules/components) that have been prepared by purification from native sources or molecular recombinant methods can enhance the clinical performance of serological IgE assays in different ways (Figures 8 and 9). Recombinant allergens can be generated with or without cross-reactive carbohydrate determinants while allergenic molecules purified from native sources will have a mixture of isoforms and carbohydrate determinants. All available allergenic molecules of one allergen source can be used as a mixture in place of a complex natural allergen extract mixture (Figure 9A). While this approach is theoretically feasible,¹⁴² so far it has not been considered as a serious option since it is considered cumbersome, possibly not all inclusive of relevant allergens, expensive and thus of questionable benefit. A second approach has been to use allergenic molecules individually as single reagents in a singleplex or as individual replicate spots in multiplex microarray assays for targeted allergen-specific IgE detection (Figure 9B – 1 component). This is at present the most common use of molecular allergens. The most extensively used components are those from peanut (Ara h 1,2,3,6,8,9) and hazelnut (Cor a 1,8,9,14) that are used to clarify specific versus cross-reactive sensitivities in the assessment of

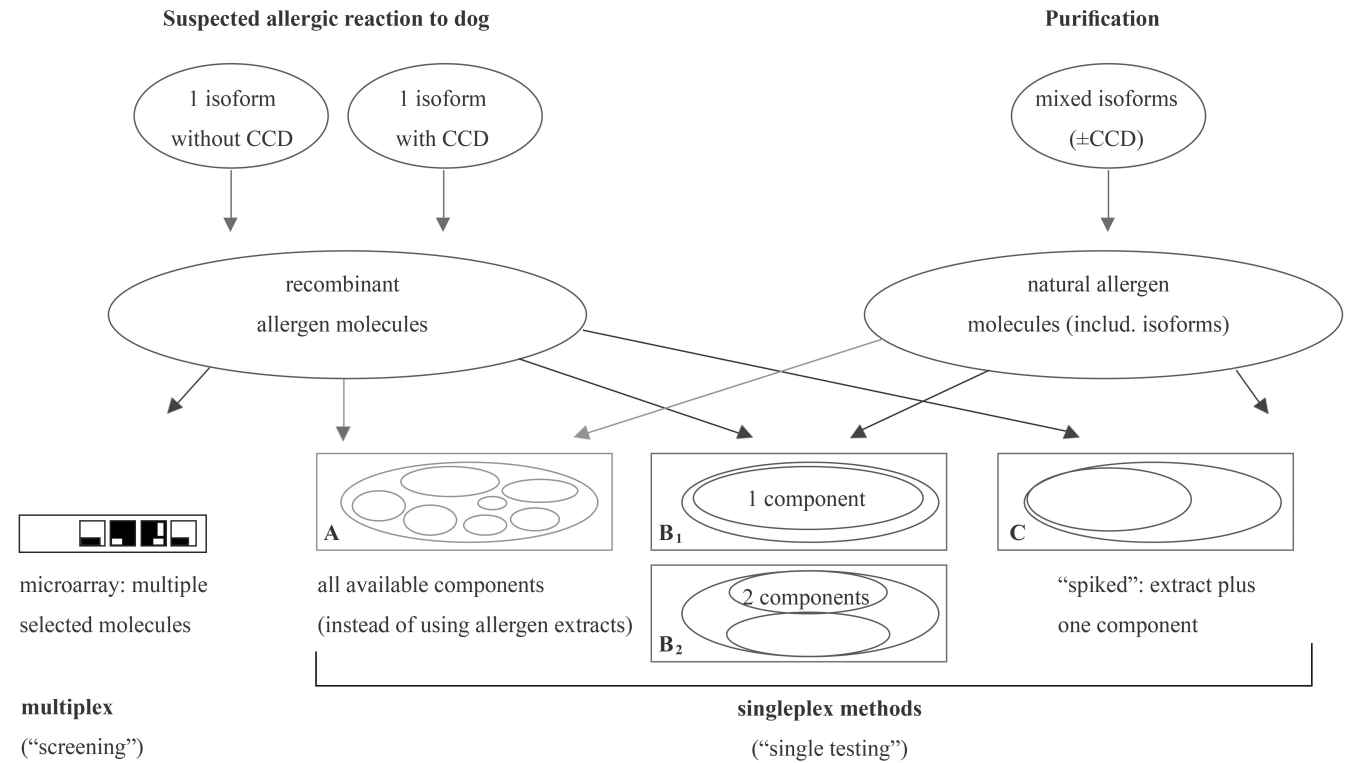
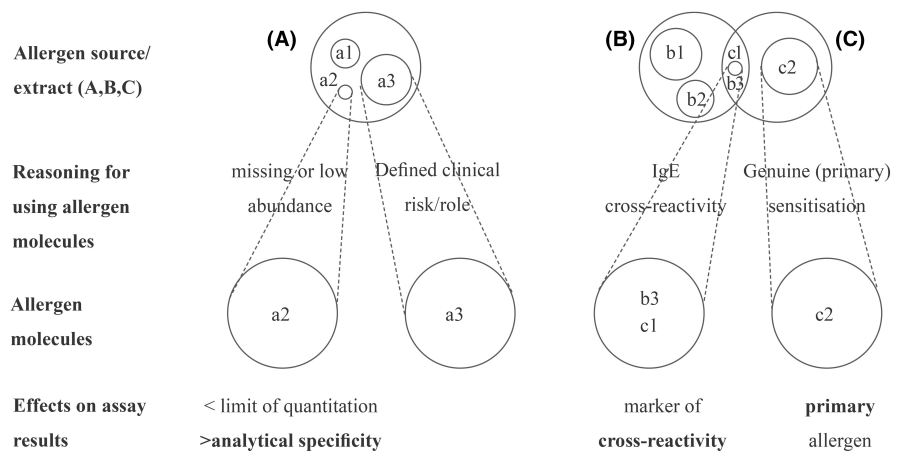


FIGURE 9 Use of recombinant (with and without CCD) and purified natural allergenic molecules. Single and mixed isoforms are immobilized in single solid phase (singleplex) or in multiple spots on multiplex microarray solid phases for use in various IgE antibody assays. Reproduced with permission from [151], recombinant production, purification, 1 isoform without CCD, 1 isoform with CCD, mixed isoforms (±CCD), reagents: recombinant allergen molecules, natural allergen molecules (incl. Isoforms), microarray multiple selected molecules, all available components (instead of using allergen extracts), 1 component, 2 components, "spiked": extract plus one component, multiplex ("screening"), singleplex methods ("single testing")

FIGURE 10 Reagent patterns based on allergen sources/extracts (upper row), with typical reasons why it is valuable to use allergen molecules as reagents in allergen-specific singleplex IgE assays (middle row) and how IgE anti-allergenic molecule results can enhance the final analytical sensitivity and specificity of the generated assay results. Table 3 provides specific examples that correspond with the conditions depicted in Figure 10.



individuals with positive peanut and/or hazelnut extract specific IgE responses. Third, selected single molecular allergens of a given allergen specificity can be combined and used as single molecular mixtures for allergen-specific IgE detection (Figure 9B - 2 components). To illustrate this approach, an equal molar mixture of the unique marker allergens Phl p 1 and Phl p 5 for Timothy grass sensitization are excellent representatives of sweet vernal grasses. Alternatively, a combination of highly cross-reactive allergenic molecules like Phl p 7 and Phl p 12, which are the polcalcin and profilin representatives of Timothy grass pollen can be used to identify a patient's

sensitization to other cross-reactive polcalcin and/or profilin pan-allergen specificities. Fourth, single components can be added to allergenic extracts ("spiked") to increase assay sensitivity. This has been particularly useful for *Hevea brasiliensis* latex where Hev b 5 is underrepresented as a result of being in low abundance or missing from certain extracts (Figures 9C and 10A). While, spiking physiological allergen extracts can enhance the assay's limit of quantitation and increase its analytical sensitivity, it can also lead to problems. For instance, supplementation of the hazelnut ImmunoCAP Specific IgE test (F17) with recombinant Cor a 1 caused Bet v 1-specific IgE to

be increasingly detected. This led unsuspecting clinicians to puzzle over the elevated values of IgE anti-hazelnut in the serum of their patients who subsequently were confirmed to have birch pollen allergy.¹⁴³ The use of all available components (Figure 10A) in a microarray format can allow targeted and more precise differentiation of the individual's sensitization profile from their allergen-specific IgE response. This approach has been coined "Component-Resolved-Diagnostics" (CRD)¹⁴⁴ and it represents the most important option in molecular allergy diagnosis.

The utility of single allergenic molecules can be justified by four conditions (Figure 10 and Table 3).^{69,145} First, the assay's sensitivity can be improved by lowering its limit of quantification (LoQ) while increasing its analytical specificity. Second, if allergen molecules are in low abundance or missing in the extract such as Cor a 1 in hazelnut or Gly m 4 in soy, supplementation improves the assay's sensitivity (LoQ). Third, if allergen molecules are unique to a specificity such as Fel d 1 for cat or Bet v 1 for birch, their use can improve the analytical specificity ("selectivity") of the assay. This allows additional clinical assumption(s) such as assessing increased risk for severe symptoms. Finally, certain allergenic molecules such as Ara h 8 (Bet v 1 homologue) for peanut and Phl p 7 and 12, the polcalcin and profilin representatives in Timothy grass, can serve as indicators for serological cross-sensitizations through the binding of cross-reactive IgE. In case of a positive result, they can demonstrate the lack of analytical specificity of an IgE test with allergen extracts in affected subjects with potential cross-reactions.

Diagnostic Allergen DataBase (DADB) Despite the availability of multiple established¹⁴⁶ databases that provide nomenclature, structure, and reference referrals for molecular allergens,^{146,147} none of these databases provide a comprehensive listing of the internationally-accepted nomenclature codes and Linnean system descriptors of the ~1000 extract-based and molecular allergens used world-wide in diagnostic single- and multiplex IgE antibody assays. An international scientific committee of the Clinical and Laboratory Standards Institute has prepared the Diagnostic Allergen DataBase (DADB)^{148,149} to specifically provide these data in a readily-searchable Excel database. The DADB lists the allergen's unique assay code (f13), general category (food), principal IgE antibody assay method(s) where the allergen specificity is available, common name (peanut), taxonomical name (*Arachis hypogaea*), and the NCBI, NPU, LOINC, Allergome, and IUIS/WHO descriptor codes for allergens and their assays. The DADB is intended for use by manufacturers of allergen-specific IgE assays, allergen extract manufacturers, government regulators, International IgE antibody assay proficiency testing programs, clinicians, and the allergic patient. Its goal is to bring unambiguous clarity to the allergenic specificity being reported by single and multiplex IgE antibody assays being performed world-wide.

Assay performance evaluation: Assay sensitivity and analytical specificity (selectivity).

The analytical performance characteristics of laboratory tests and their predictive value in defining the presence and severity clinical disease have been internationally defined by variables such as

Textbox 8 Common definitions to describe performance characteristics of a laboratory test (i.e., allergen-specific IgE assay)

Analytical sensitivity is equivalent to the slope of the calibration curve of an (immune)assay. By contrast, assay sensitivity in real terms (=lowest test "cut-off") is currently calculated and provided with following, internationally harmonized variables:

- limit of blank, LoB (i.e., signal of a serum sample without allergen-specific IgE)
- limit of detection, LoD (i.e., signal of a serum sample with the lowest detectable allergen-specific IgE)
- limit of quantitation, LoQ (i.e., signal of a serum sample with the lowest allergen-specific IgE at a predefined assay precision)

Analytical specificity of an allergen-specific IgE assay can, first, be related to the specificity of the detected immunoglobulin class, meaning the test will indeed measure IgE and not immunoglobulins of other isotypes and subclasses (IgA 1/2, IgD, IgG1-4 or IgM)

A second definition relates analytical specificity to a targeted, more selective IgE detection against single allergenic molecules. While an allergen extract consists of complex protein mixtures, ideally the assay binds the entire IgE repertoire to a specific extracted allergen source. The use of single allergen molecules will only detect a part of the IgE repertoire. Thus, the analytical specificity (selectivity) will be increased.

sensitivity and specificity (Textbox 8).^{69,145} Two pairs of definitions separate the IgE antibody test's analytical sensitivity and specificity (Table 4, left column, 1-4) from its diagnostic sensitivity and specificity (Table 4, right column, I-IV) that discriminate among the various clinical allergy phenotypes. These definitions have been adopted as part of international guidelines for IgE antibody assays through the Clinical and Laboratory Standards Institute (CLSI). They are particularly important to consider when allergenic molecules are substituted into an IgE antibody assay.¹⁴² Their importance stems from the observation that introducing single allergenic molecules into an IgE antibody assays frequently improves the analytical variables in the left column of Table 3 and this has a direct effect on changing the diagnostic clinical discrimination of disease as defined by the parameters in the right column of (Table 3).

The extent to which an assay performance improvement translates into improved diagnostic clinical discrimination of disease depends on (a) the cohort of individuals being evaluated in terms of their age, disease spectrum and severity, (b) the availability and selection of the specific allergenic molecules used in the IgE assay, and

TABLE 4 Potential criteria for assessing assay improvement of sensitization tests following the replacement of allergen extracts with allergenic molecules

analytical criteria (potential assay improvement)		diagnostic-clinical criteria (potential clinical advantages)	
1	> "analytical" sensitivity < limit of quantitation (LoQ)	I.	> diagnostic sensitivity (proportion of positive IgE antibody tests in patients with allergic disease)
2	> analytical specificity	II.	> diagnostic specificity (proportion negative IgE antibody tests in healthy individuals)
3	indicator of serological cross reactivity	III.	indicator of clinical crossreactivity (allergic symptoms to allergenic sources that did not elicit the primary sensitisation)
4	marker of primary/genuine sensitisation	IV.	prediction of clinical reactions (PPV, NPV, thresholds, likelihood ratio etc.)

(c) the preselected study endpoints defined by the clinician.¹⁴⁸ This means that the diagnostic-clinical criteria (right column, I-IV, Table 4) need a thorough individual interpretation based on each IgE antibody test result using the patient's previous history and if needed, additional proof of reproducible and objective symptoms in the affected allergic subject upon allergen exposure (i.e., challenge test). As a consequence, these clinical criteria extend beyond the essential "raw" allergen-specific IgE antibody assay result (e.g., IgE sensitization in question: yes or no). Together these facts support the conclusion that it can be misleading to use sensitization test results alone to define the diagnostic clinical criteria of an IgE antibody test.^{142,148}

One example is enhancement of the analytical sensitivity of an IgE antibody assay by supplementing an extract with a labile allergen molecule (Hev b 5 into the *Hevea brasiliensis* extract) prior to use in preparing the allergosorbent. The additional Hev b 5 improves the analytical sensitivity by lowering the assay's limit of quantitation (LoQ), and thus increasing the test's diagnostic sensitivity without compromising the analytical specificity of the test. Alternatively, in patients with wheat-dependent, exercise-induced anaphylaxis (WDEIA), only 20–30% of the subjects have IgE-mediated sensitization to wheat flour extract. However, 80–90% of these cases demonstrate allergen-specific IgE to Tri a 19 (Omega-5-gliadin). This gliadin is often responsible for WDEIA; however, it suffers from a poor aqueous solubility and is therefore not well represented in wheat extracts. By using recombinant Tri a 19 as a reagent in the IgE antibody assay, the assay's sensitivity (lowered LoQ) is immediately improved.

Another asset of the use of defined allergenic molecules is the restriction that it provides to the assay. This is especially important when IgE immune responses need to be detected to allergenic specificities that are highly stable or in relatively high abundance (i.e., Ara h 2 or Cor a 14). Their use makes the measurement of IgE antibody more targeted or analytically specific. Identification of IgE immune response patterns to the 2S albumins, Ara h 2 and Cor a 14 (Table 4), have been repeatedly associated with an increased risk for severe reactions to foods and they can facilitate decisions about

the possible elimination of an oral food challenge. Alternatively, in a nonselected population study, more than 10% of German children and adolescents demonstrate allergen-specific IgE to peanut extract that is predominantly linked to serological pollen-associated cross-reactions.¹⁵⁰ Moreover, diagnostic tests with the stable and risk-associated peanut storage allergen (Ara h 2) show elevated allergen-specific IgE in only a small proportion of the general children/adolescent population (approximately 0.2% to 0.4%) (Kirsten Beyer, personal communication). Thus IgE anti-Ara h 2 provides a much higher analytical specificity ("selectivity") than the use of a peanut extract based allergosorbent.

12 – Clinical evaluation: diagnostic sensitivity and specificity

Diagnostic sensitivity and specificity are related to a clinical history and physical examination based assessment of affected and nonaffected subjects. Requirements for proper calculation and interpretation of the diagnostic sensitivity and specificity of IgE antibody tests of sensitization require sound clinical data from the subject's case history and in some cases additional challenge tests to back up the clinical diagnosis (Table 4, right column). However, the presence of allergen-specific IgE is strictly a marker for allergic sensitization (risk for allergy) and it alone cannot predict the probability of a clinical reaction per se. Thus, concordant results (case history and allergen-specific IgE with a positive clinical or challenge outcome) are effectively considered as clinically relevant (rather than being labeled as true positive). The same applies for concordant negative results, which are used to exclude a clinical state of allergy and an underlying state of allergic sensitization. In case of positive allergen-specific IgE results and a negative case history or provocation test, however, consideration should be given to labeling these discordant results as clinically irrelevant (rather than false positive diagnostic tests). Labeling clinically irrelevant as false positive test results actually

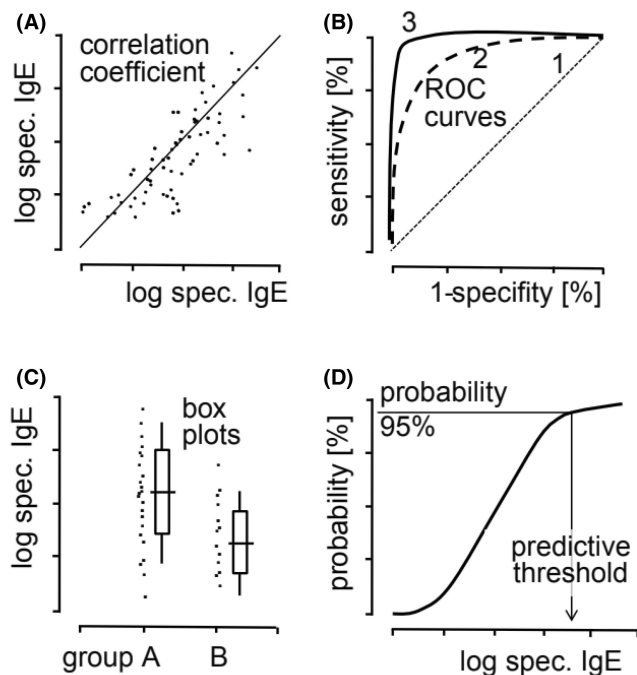


FIGURE 11 Typical data analyses of IgE antibody laboratory data with single allergenic molecules

misses the key point of the analysis, since the presence of allergen-specific IgE itself should not be disputed, but rather considered valid in its own right as a marker for atopy and IgE sensitization.¹⁴⁸ A number of clinical studies have explored diagnostic sensitivity and specificity of IgE tests with single allergens from a particular allergen source. The use of previously missing or less represented allergens in IgE antibody assays was able to increase its diagnostic sensitivity through the improvement of assay sensitivity, usually by lowering the assay's limit of assay quantitation (Tables 3 and 4). As a consequence, higher rates of sensitization were found, in general, even among subjects without clinically relevant reactions or disease.

The reciprocity of diagnostic sensitivity and specificity is a general feature of diagnostic tests. It is usually depicted as Receiver Operating Characteristics (ROC) curves (general example see Figure 11B). Some single allergens like Ara h 2 or other risk-associated allergens belonging to the seed storage protein family of 2S-albumins have been found to increase diagnostic sensitivity and specificity of a patient's evaluation by assessing the risk of severe clinical reactions. Using risk-associated 2S-albumins, predictive allergen-specific IgE thresholds ("decision points") have been defined to forecast a positive or negative oral challenge in children with peanut or hazelnut allergy¹⁵⁰ diagnostic sensitivity and specificity, predictive values and likelihood ratio. (Table 3, right column), the analytical performance of IgE assays can be substantially improved in many cases by allergenic molecules that are used in parallel with or in place of allergen extracts. This conceptual view has already been adopted by international guidelines on allergen-specific IgE assays. It should further facilitate and possibly accelerate the evaluation and

clinical acceptance of allergenic molecules into the diagnostic algorithm for human allergic disease.¹⁵¹

A: Association of log distributed allergen-specific IgE concentrations to a natural (x axis) versus recombinant (y-axis) allergen molecules. B: Diagnostic efficacy (receiver-operating characteristics, ROC) displaying performance of IgE antibody assays with allergen molecules as compared to extracts; C: Single values of allergen molecule-specific IgE antibody with the median, 25% and 75% percentiles that are presented to compare groups. D: Threshold levels of IgE antibody that are used to predict the probability of a clinical reaction (i.e., 95% probability of a positive oral food challenge) Despite the performance of elaborate and elegant clinical studies, they have produced rather variable outcomes with group effects, displaying considerable overlap between, i.e., clinically affected and nonaffected (tolerant) individuals (Figure 11C). Presenting data with smoothed probability plots (Figure 11D) suggests a close relationship, suitable for individual prediction with the collected data. However, results of sensitization tests like the allergen-specific IgE assays cannot yet (and presumably never will) reliably predict clinical reactions (or their nonappearance).^{148,152} Therefore, future studies on the diagnostic value of allergenic molecules should establish as their primary goal, the improvement of well-defined methodological variables (Table 3, left column) that are linked to the analytical performance characteristics of the assay. This should be done even without a complete clinical evaluation of the assay, which includes the assessment of the assay's.

13 – Determination of the clinical relevance of an IgE antibody assay

The ultimate and essential question with diagnostic allergy testing is "what is the clinical relevance of an allergen-specific IgE measurement"? Even in this era with the availability of molecular allergens, the basic rule still applies. Namely, a positive allergen-specific IgE result represents a state of allergic sensitization (risk for allergic disease) but not proof of allergic disease.^{69,145,148,152} A positive IgE antibody response is only clinically relevant in the case that there are objectively defined corresponding allergic symptoms that are temporally associated with a known allergen exposure. A negative allergen-specific IgE result against one recombinant allergen molecule or a mixture of natural isoforms of one single allergen can generally exclude an allergic sensitization or risk of allergy to that allergen specificity in question. This is, however, only possible if the total IgE is high enough (i.e., >20 kU/L), the allergen reagent is in sufficient abundance, fully intact, and presenting all its epitopes and the analytical performance of the IgE antibody assay has been optimized for a low limit of quantitation (i.e., 0.1 kU/L, 0.24 ng/ml).

In conclusion, the clinical relevance of an allergic sensitization (i.e., presence of allergen-specific IgE) independent of the use of allergen extracts or molecules for diagnostic purposes can

ultimately only be determined by the physician and not by the test.^{69,145,148,152} Therefore, the complete diagnostic results of sensitizations tests, including allergen-specific IgE assays that have been improved by the use of allergenic molecules, will always have to be interpreted within the individual's clinical context and on the basis of their case history.

14 – Summary

For the foreseeable future, clinically validated singleplex assays that use allergen extract-based reagents will remain the principal assays and reagents employed worldwide by clinical immunology laboratories to serologically document sensitization (IgE antibody) in individuals with a positive history of allergic symptoms. Allergen extract-based reagents are being judiciously supplemented with an increasing number of allergenic molecule-based reagents. Their routine use in singleplex assays enhances diagnostic accuracy, predictability of risk for severe reactions and documentation of cross-reactivity. In Europe, novel molecular allergen-based multiplex assays have become more common in diagnostic allergy testing after demonstrating compliance with new IVD-R quality standards. However, in the rest of the world, they will remain invaluable research assays,

until such time as their government regulatory agencies have an opportunity to review multiplex assay performance data. The molecular allergens from peanut and hazelnut provide a pathway for other molecular allergens to be increasingly considered for use in routine diagnostic allergy testing. They have been shown to (a) improve analytical sensitivity by providing molar excess of missing or low abundant allergens (e.g., Ara h 8 in the peanut extract; Cor a 1 in the hazelnut extract), (b) enhance the assay's analytical specificity by defining a clinical risk for systemic reactions (Ara h 1,2,3 [severe] versus Ara h 8 [more mild]) and (c) distinguish cross-reactivity versus (d) genuine (primary) sensitization (Cor a 9,14 [genuine] versus Cor a 1 [Bet v 1 cross-reactive] sensitization to hazelnut). The clinical relevance of allergen-specific IgE detection in a patient's serum is strictly as a marker for allergic sensitization (risk for allergy) and it alone cannot predict the probability of an allergic reaction. The determination of the diagnostic sensitivity and specificity of IgE antibody assays will thus remain difficult to definitively determine because of the lack of an absolute (gold standard) method of defining the presence of allergic disease. This means that the clinical relevance of an allergic sensitization (i.e., presence of allergen-specific IgE) independent of the use of allergen extracts or molecules for diagnostic purposes will ultimately be determined only by the physician and not by the test.

A05 – Basophil activation test

Alexandra F. Santos, Bernadette Eberlein, Peter Korosec, Hans-Jürgen Hoffmann, Edward F. Knol

Highlights

- The basophil activation test (BAT) is a functional test that goes beyond detecting the presence of IgE to measure whether IgE is able to induce cellular activation and degranulation.
- The BAT can be useful to confirm the diagnosis of food, venom and respiratory allergies.
- In the BAT, both allergen extracts and individual molecules can be used to stimulate the basophils and the latter can provide higher specificity in the case of some allergen sources.

1 – Introduction

In allergy diagnostics is important not only to test for IgE binding to allergens in a serological assay but also to test the functional interactions of allergens with IgE on effector cells.¹⁵³ This can be tested *in vivo* using skin prick test (SPT); however, SPT requires the appropriate clinical set up with the resources and expertise required to treat acute allergic reactions and does not allow for testing of recombinant allergen components, or even purified components. The Basophil Activation Test (BAT) is an *in vitro* diagnostic test that demonstrates the function of IgE in its ability to induce effector cell activation following stimulation with the allergen. Activation of basophils can be analysed by measuring the mediators released, such as histamine, or the change in plasma membrane markers, such as CD63, that happen during basophil degranulation.¹⁵⁴ CD63 is of particular interest because it is expressed on the membrane of the the histamine-containing granules of basophils and is exposed on the plasma membrane after degranulation as the granules fuse with the plasma membrane.¹⁵⁵ The BAT has developed into a robust and straightforward assay that can be implemented in many laboratories using flow cytometry. In addition to supporting the diagnosis of food, insect venom and drug allergies, this test also allows monitoring the acquisition of tolerance in allergic patients. This can be spontaneous tolerance, e.g., in cow's milk allergy in infants who outgrow their allergy, or induced tolerance after Allergen Immunotherapy (AIT) for food, venom, or aero-allergens. Moreover, BAT has been instrumental in the characterization of the potency of allergen components.^{54,156}

This chapter will provide an overview of the methodology for BAT, its potential role in the diagnosis and management of food allergy, insect venom allergy and respiratory allergy. In addition, the advantages and the limitations of the BAT will be discussed.

2 – Methodology

For basophil testing, allergen and fluorochrome-conjugated antibodies are required.¹⁵⁶ Heparinized or EDTA-stabilized blood can be used.¹⁵⁷ Normally, 50 – 100 µl of blood are used per assay. In contrast to skin prick testing, anti-histamines do not affect the outcome of BAT.¹⁵⁸ However, treatment with ibrutinib¹⁵⁹ reduces basophil activation and oral steroids can induce¹⁶⁰ basopenia.¹⁶¹ An advantage of the BAT is that it is flexible with regards to the allergen added. Commonly used allergen concentrations are listed in the online supplement of the EAACI position paper on basophil activation.¹⁵⁶ Allergens are added in either 1/10 of the volume of blood used, or in an equal volume depending on the BAT method adopted. Protein allergens like birch, pollen grass pollen or house dust mite allergens are added in concentrations ranging from picogram to microgram per millilitre. Often, basophils in a blood sample will react at four to six of the nine allergen concentrations used, so the response can be extremely dynamic. Sensitivity of blood basophils of an individual successfully treated with allergen immunotherapy may change by 2-3 orders of magnitude and be associated with clear clinical improvement¹⁶² that persists for years.^{163,164} To improve determination of the sensitivity, half log spacing of the samples may be used. In clinical practice, one may restrict analysis to the range of concentrations at which the basophil response often is dynamic.

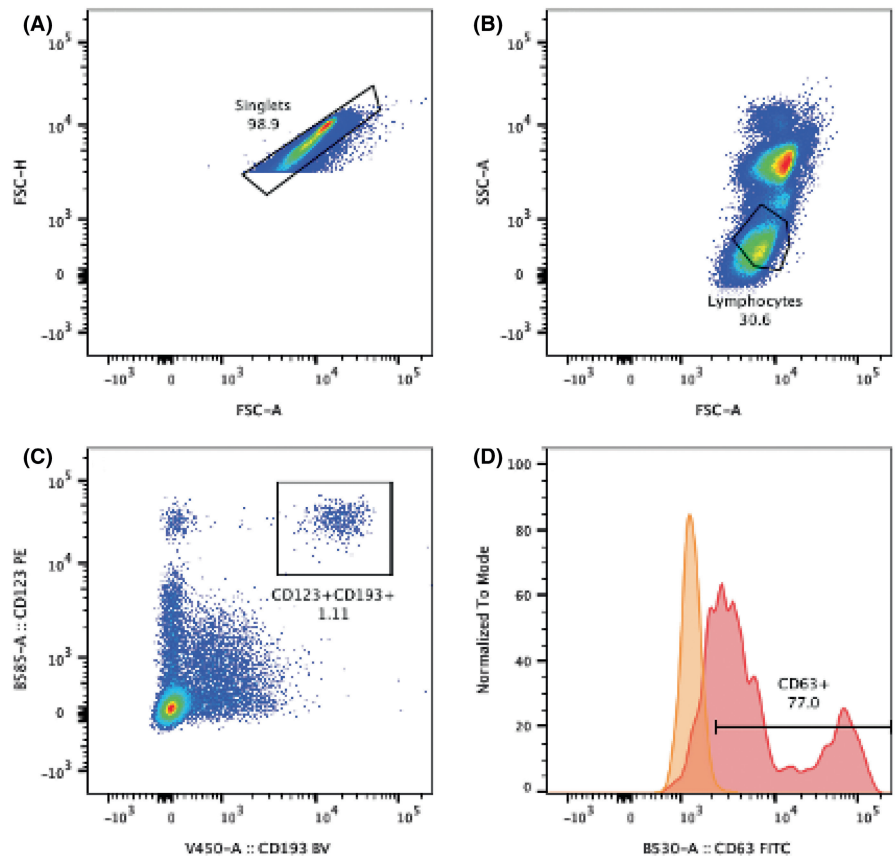
Drugs in the BAT are used at higher concentrations than protein allergens—often in the microgram to milligram per millilitre range, and are often tested in five-fold dilutions. Drugs may interact with endogenous proteins to form noncovalent tertiary structures or covalent adducts that can be recognized by IgE on basophils—the so-called haptization.¹⁶⁵ The response induced by these structures is thus less dramatic than that of protein allergens.

Basophils are identified by fluorochrome conjugated antibodies directed to CD193, CD203c, IgE, or CD123/ HLA-DR, with greater precision being achieved with the combination of two or more antibodies. Activation is measured using antibodies directed against CD63 (Figure 12) or, CD203c. There are other markers that are up- and downregulated on activated basophils, such as CD107a and diaminoxidase DAO, and can be used as alternative measures of basophil activation.^{166,167} Antibodies should always be titrated before use; first the antibodies used to identify basophils and afterwards the activation markers, using anti-IgE or allergen-activated basophils.

Blood, allergen and antibodies can be combined and warmed to 37°C for between 15 and 45 minutes in a water bath or incubator. After that, the sample should be hemolysed and analysed by flow cytometry.

For analysis of flow cytometry data, doublets are excluded on a forward scatter area versus height plot, followed by a forward scatter versus side scatter plot in which the region containing basophils

FIGURE 12 Example of a BAT analysis (Hoffmann Lab). A FSC-A vs FSC-H plot to select single events, B. FSC-SSC plot to identify basophils by scatter parameters, C CD193 vs CD123 Plot to identify basophils as double positive events, D Histogram for CD63 expression, where the threshold is set to include 2% of the negative population. 77% of activated cells express CD63.



between lymphocytes and monocytes is gated upon. In this region, single- or double-positive cells expressing selective antigens are identified. A threshold should be set on a population of non-stimulated basophils to measure activation in stimulated conditions—a threshold of ca. 2% of CD63 expression is desirable. A donor is a non-responder if there is no activation through IgE/FcεRI pathway, but there is response to non-IgE-mediated stimulants.¹⁶⁸ Patients that are nonresponders have uninterpretable results for BAT.

3 – Food allergy

The BAT can be a powerful tool to support the diagnosis of food allergy.¹⁶⁹ As the presence of allergen-specific IgE is not enough to confirm food allergy, the BAT can help to assess the function of allergen-specific IgE and determine whether allergen-specific IgE is able to induce effector cell activation following exposure to the allergen, which can help to establish the clinical relevance of a given IgE sensitization.^{170,171} This is particularly useful in the absence of a clear history of an allergic reaction to a specific food or when there is discrepancy between the history and the results of IgE testing. Both food allergen extracts and individual allergen components can be used for basophil stimulation in the BAT, alongside the positive controls, IgE (anti-IgE or anti-FcεRI) and non-IgE-mediated (e.g., fMLP).⁵⁴ Table 5 summarizes some of the published studies using allergen components in the BAT. Generally, using individual allergens can be more specific than using allergen extracts; however,

the broader sensitization profile is lost and could potentially lead to false-negative results for patients sensitized to allergens not included in the BAT.

The BAT has been used to distinguish primary from secondary food allergies and to establish the relevance of sensitization to fresh plant foods, such as apple. Primary apple allergy is associated with a shift in the dose-response towards lower concentrations of apple extract.¹⁷² Primary apple allergy can also be confirmed using molecular allergens, such as Mal d 3, the apple LTP, in the BAT, similar to what was previously shown for peach allergy with BAT to Pru p 3.¹⁷³ BAT is also useful to assess and compare allergenicity of individual components and their isoforms, which is not only important for food safety but also to guide development of hypoallergenic cultivars.^{174,175}

Given BAT's high specificity, it is very useful to confirm the diagnosis of food allergy and therefore can preclude the need for oral food challenges (OFC) in individuals that would otherwise develop an allergic reaction following exposure to the suspected allergen. In peanut allergy studies, BAT using peanut extracts reduced the number of OFC by 67% to 70% and even to 80% when also including specific IgE in the diagnostic algorithm.^{176,177} This approach has been validated in another study of peanut, sesame, and tree nut allergies¹⁷⁸ and gave rise to the diagnostic approach proposed in Figure 13.^{54,179}

For differentiation of patients with a clinically relevant alpha-gal syndrome and alpha-gal-sensitized subjects, commercially available alpha-gal-carrying proteins and pork kidney extracts using adequate

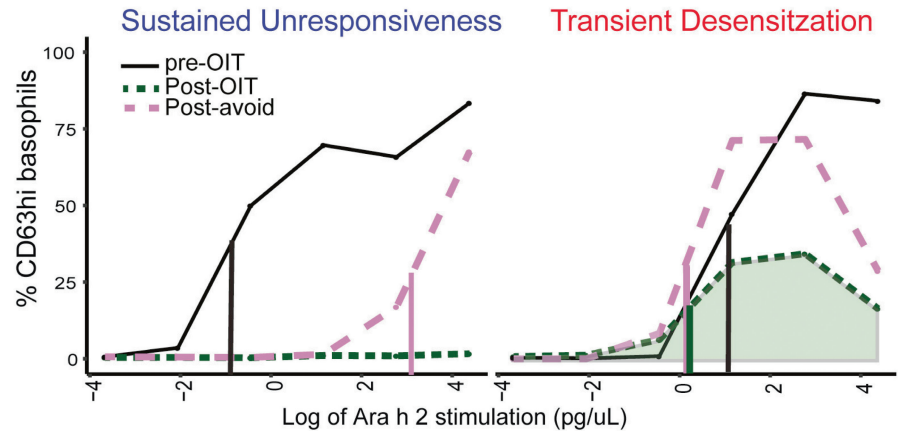
TABLE 5 Basophil activation test to allergen components in food allergy

Allergen	Molecular allergen	Source	Concentrations	Comparison to extract and/or clinical relevance	Reference
Cow's milk	Casein (nBos d 8)	Commercially available	0.1-10-1000 ng/ml	Lower sensitivity and specificity than cow's milk extract	[197]
	Casein (Bos d 8) Alpha-Lactalbumin (Bos d 4) Beta-Lactoglobulin (Bos d 5)	Commercially available	Casein: 1 – 400 ng/ml Alpha-Lactalbumin, beta-Lactoglobulin: 10 – 200 ng/ml	Not much added value of components compared to cow's milk extract	[198]
Egg	Ovomucoid (nGal d1)	Trypsin inhibitor from purified hen egg white ovomucoid type III-0, Commercially available	0.1-10-1000 ng/ml	Higher sensitivity and specificity than egg white extract	[197]
	Ovomucoid (Gal d 1) Ovalbumin (Gal d 2)		0.5 ng/ml - 5 mg/L	Difference to egg white not calculated, but in the same range	[183]
Wheat	Omega-5 gliadin (nTri a 19 and rTri a 19)	Natural protein purified from wheat flour, recombinant protein expressed in <i>E.coli</i>	10-100-1000-10,000 ng/ml	Similar sensitivity and specificity as wheat allergen extract	[199]
	Hydrolyzed wheat protein (HWP), Omega-5 gliadin (nTri a 19)	Natural protein purified from wheat	0.0001 – 1 µg/ml	Higher activation with HWP in HWP-WDEIA, higher activation with W5-gliadin in CO-WDEIA	[200]
	ω5-, ω1,2-, α-, γ-gliadins, high- and low molecular-weight glutenin subunits (HMW-, LMW-GS,) gluten	Natural protein purified from wheat flour	0.08-4.0 mg/mL	Sensitivity of ω5-gliadins: 100% Sensitivity of HMW-GS: 75%	[201]
Peanut	Ara h 1 Ara h 2 Ara h 6	Commercially available	0.1820-4.545 ng/ml	Ara h 2: Higher sensitivity and specificity than peanut extract, Ara h 1 and Ara h 6	[178]
	Ara h 2 Ara h 6	Purified peanut proteins	0.1-1000 µg/mL	AUC value of Ara h 6 slightly higher than Ara h 2	[177]
	rAra h 8	Commercially available	0.05 – 500 ng/mL	More positive CD-sens Ara h 8 compared to peanut in children with IgE-ab to birch and rAra h 8, but not to rAra h 1, Ara h 2 and Ara h 3.	[202]
	Ara h 1, Ara h 2, Ara h 3, Ara h 6, Ara h 9	Commercially available	0.1 µg/mL	High sensitivity to Ara h 9, but only Ara h 2 was able to discriminate peanut-allergic subjects	[203]
	3 Ara h 7 isoforms	Commercially available	1000 ng/mL	Sensitisation to Ara h 7.0201 equally potent as Ara h 2.0201 and 6.01	[204]
	Peach	Pru p 3	Recombinant allergen \ expressed in <i>P. pastoris</i>	100-300 ng/ml	Lower sensitivity and higher specificity compared to peach extract
rPru p 3 rMal d 3		Recombinant allergen expressed in <i>P. pastoris</i>	0.001-0.01-0.1-1 µg/mL	Symptomatic patients in Barcelona seem to be more sensitive to lower allergen concentrations compared to patients in Antwerpen	[173]
Peach-LTPs Pru p 2.0101 Pru p 2.0201 Pru p 2.0301		Purified peach proteins (Pru p 2.0101, Pru p 2.0201), recombinant allergen expressed in <i>P. pastoris</i> (Pru p 2.0301)	25, 10, 1 and 0.1 µg/mL	Pru p 2.0201 most active of the three isoforms, recognized by 80% of patients (Pru p 2.0101: 60%, Pru p 2.0301: 50%).	[175]
Celery/ carrot/ apple	Api g 1 Dau c 1 Mal d 1	Commercially available	10 ⁻⁵ – 100 µg/mL	Sensitivity for Mal d 1, Dau c 1, Api g 1: 75%, 65%, 75% specificity: 68%, 100%, 77% in patients with OAS	[206]
Strawberry	8 Fra a 1 proteins	Recombinant allergens expressed in <i>E.coli</i>	0.5-500 ng/mL	Fra a 1.02 and Fra a 1.03 highest activation	[174]
Meat/innards	Alpha-Gal	Commercially available	0.022-2272 ng/mL	Equal sensitivity compared to pork kidney extract	[180]
Shrimp	rPen m 1 (tropomyosin)	UniProt ID: A1KYZ2; expressed in <i>E. coli</i>	100-10,000 ng/ml	Lower sensitivity and higher specificity compared to shrimp extract	[207]
Fish	α- and β-parvalbumins	Purified fish proteins	0.1 – 1000 ng/ml	Reduced basophil activation by α-parvalbumins compared with β-parvalbumins in individuals allergic to bony fish	[208]



FIGURE 13 Proposed clinical approach to the diagnosis of IgE-mediated food allergy

FIGURE 14 Patterns in the BAT over the course of peanut oral immunotherapy can predict the response to treatment and prognosis [186].



basophil parameters can be diagnostically useful.¹⁸⁰ In a different study, BAT to cow's milk was able to predict spontaneous resolution of cow's milk allergy.¹⁸¹

Following a precise diagnosis, BAT can potentially help document the change with specific treatments for food allergy, like allergen-specific immunotherapy or biologicals. Typically, following allergen-specific immunotherapy, a reduction in basophil reactivity and sensitivity is observed with lower proportion of activated basophils for a given allergen concentration, a shift in the dose-response towards higher concentrations of the allergen and lower area under the dose-response curve.^{182,183} A reduction in basophil reactivity to bystander allergens and IgE-mediated stimulants during allergen-specific immunotherapy has also been reported.¹⁸⁴ These effects tend to disappear with interruption of treatment, particularly in the patients whose symptoms recur.¹⁸⁵ Importantly, the BAT has shown to be able to predict the response to oral immunotherapy as early as 3 months into treatment with patients with sustained unresponsiveness and patients with transient desensitization showing different patterns of basophil response.¹⁸⁶ (Figure 14).

Following treatment with omalizumab, two factors have been shown to contribute to the change in basophil response: on one hand, the reduction in IgE on the surface of basophils leads to reduction in basophil reactivity, and on the other hand the reduction in IgE receptor density leads to a greater basophil sensitivity.¹⁸⁷⁻¹⁸⁹ The overall effect results from the combination of these two factors. A better response is expected from patients with a lower IgE specific activity, i.e., a lower proportion of IgE that is specific for that allergen.¹¹⁰

An additional application of the BAT is to determine potency of individual food allergens within a food extract, and to evaluate effects of food processing.^{51,190-195} BAT could potentially be used to

detect the presence of allergens in complex mixtures and to test for possible food allergen contaminations.¹⁹⁶

Further standardization and quality assurance are required for mainstream use of BAT to support food allergy diagnosis and follow up of patients during the course of immunomodulatory treatments. Studies confirming its utility in place of OFC both for diagnosis and follow up in a real-life setting alongside with cost effectiveness and impact studies would be informative to support the incorporation of BAT in clinical guidelines.

3 – Insect venom allergy

Hymenoptera venoms are complex mixtures of a variety of substances including numerous potential allergens. The knowledge of the composition of hymenoptera venoms and the use of recombinantly produced CCD (cross-reactive carbohydrate)-free hymenoptera venom allergens has improved diagnostics and led to the field of molecular or component-resolved diagnostics. In recent years, identification and characterization of new allergens of Hymenoptera venoms by biochemical and molecular biological methods have made significant progress, shifting the focus from the whole venom to individual allergenic molecules.^{209,210}

The use of recombinant insect venom components in basophil activation testing began with the use of rVes v 1 and rVes v 5 in two yellow-jacket-venom (YJV) sensitized patients showing a CD63 basophil activation of up to 90% and with the recombinant allergens rVes v 3 compared to rVes v 5 and with rApi m 5 compared to rApi m 1 in single patients revealing different individual dose-response curves in insect venom sensitized patients.^{99,211} Also in 8/13 honey bee venom (HBV) allergic patients rApi m 10 was able to induce

basophil activation upon almost 100%.²¹² In 43 patients with YJV allergy the use of the four recombinant allergens rVes v 1, rVes v 2, rVes v 3 and rVes v 5 in the BAT was investigated. BAT with rVes v 5 provided a specificity of 100% and a sensitivity of 81% whereas BAT performed with natural venom showed only a specificity of 94.1 and a sensitivity of 68.3%. Additionally, BAT performed with rVes v 5 followed by rVes v 3 was the most sensitive and specific procedure among all recombinant allergens tested. Furthermore, some patients were detected being negative to rVes v 5 but positive to other recombinant allergens or conventional venom extract in the BAT. Therefore, this test markedly improved the specificity of diagnosis in wasp venom allergic subjects when compared to respective sIgE detection in serum.²¹³ Antigens 5 are the most potent allergens in vespid venoms and are found in the venom of nearly all *Vespoidea* species with a varying degree of sequence homology. BATs were performed in 21 YJV-allergic patients with the recombinantly produced antigens 5 of seven allergy-relevant species: *Vespula vulgaris* (rVes v 5), the hornet *Vespa crabro* (rVesp c 5), the European paper wasp *Polistes dominula* (rPol d 5), the American paper wasp *Polistes annularis* (rPol a 5), the white-faced hornet *Dolichovespula maculata* (Dol m 5), the fire ant *Solenopsis invicta* (Sol i 3), and the wasp *Polybia scutellaris* (rPoly s 5). In the BAT, the YJV-allergic patients showed different activation profiles in response to the different antigens 5. Six of twenty (30%) patients exhibited basophil activation in response to rVes v 5 and/or rVesp c 5 only. The basophils of further 11 patients (55%) were activated by either all or different combinations of antigens 5. However, in most of these patients, the basophil activation was more pronounced in response to rVes v 5 and/or rVesp c 5. Only in two patients the activation pattern was more distinct in response to other allergens than rVes v 5 and/or rVesp c 5. rPoly s 5 was also able to activate patient-derived basophils in this assay. These results demonstrated cross-reactivity of vespid venoms on a molecular basis.²¹⁴

Another allergen of *Polistes dominula* rPol d 3 showed basophil activation in *Polistes dominula* venom (PDV)—and/or YJV-allergic patients from Spain and HBV- and YJV-allergic patients from Germany and was compared with the other recombinant dipeptidyl peptidase IV allergens rVes v 3 or rApi m 5.²¹⁵

Polistes PLA2 from *Polistes dominula* venom and other HBV components (C1q-like protein (C1q) and PDGF/ VEGF-like (PVF1) were unable to activate basophils of allergic patients despite exhibition of specific IgE reactivity questioning their role in the context of clinically relevant sensitization.^{216,217} Similarly, neither the hyaluronidase of *Polistes dominula* (Pol d 2) nor of *Vespula vulgaris* (Ves v 2b) showed significant basophil activation in any insect venom allergic patient, whereas the allergen rApi m 2 caused a moderate activation in Api m 2 sensitized HBV allergic patients.²¹⁸

In 9 patients sensitized to Api m 1 and Api m 2, a conventional BAT with HBV extract revealed a higher basophil activation compared with the components nApi m 1 and rApi m 2, but in 8 patients sensitized only to Api m 1 the results were comparable. Nanocrystal-labeled nApi m 1 and rApi m 2 showed a strong positive correlation to nApi m 1 and rApi m 2 and enabled the development of a

multiplex BAT approach incorporating multiple fluorescent-labeled allergen components.²¹⁹ The lack of basophil activation by mimotopes corresponding to Api m 1 IgE epitopes could be important for the development of safer allergen immunotherapy.²²⁰

In summary, rVes v 5 and rVes v 3 appear to increase sensitivity and specificity in BAT compared with wasp venom extract in YJV allergic patients, whereas in bee venom allergic patients nApi m 1, rApi m 5, and rApi m 10 induce higher basophil activation than bee venom extracts only in single patients. Therefore, rVes v 3 and 5, nApi m 1 and 80 rApi m 5 and 10 BAT could reveal the actual and species-specific allergenic activity of those venom components and thus better elucidates the pattern of single /double positivity than components based IgE testing.¹⁷¹ Other components (e.g., antigen 5) showed pronounced cross-reactivity, or no allergenicity in BAT (Table 6).

4 – Aeroallergens

Tree pollen allergens

PR-10-like allergens are the major allergens in pollen from trees of the order Fagales. BAT with Bet v 1 is a useful and efficient approach to determine the allergic status in birch sensitized individuals (Table 7).^{221–231} BAT to Mal d 1, Api g 1, and Dau c 1 have been used to characterize PR-10-like allergens in different individuals to better distinguish cross-reactive birch-pollen-associated food allergy from sensitization without food allergy.^{206,225,232} Recently, Que m 1, a major allergen from Mongolian oak, a dominant species in Korea, was cloned, its recombinant protein was produced, and in oak-sensitized subjects, Que m 1 demonstrated a potent basophil activation in comparison to Bet v 1.²²³

Basophil testing can be used to functionally monitor IgG blocking bioactivity and humoral response induced by SCIT or SLIT.^{231,233} Recently, a basophil inhibition assay using stripped basophils re-sensitized with a serum pool containing high Bet v 1-specific IgE levels was established and used to assess CD63 expression in response to Bet v 1, Aln g 1, Car b 1, Ost c 1, Cor a 1, Fag s 1, Cas s 1, or Que a 1 after incubation with pre-Bet v 1 SLIT or post-Bet v 1 SLIT sample.²²⁴ This study demonstrated highly variable and nonpredictable Bet v 1 SLIT cross-blocking bioactivity to PR-10-like allergens of Fagales tree pollen. Similarly, Bet v 1 SLIT also induced limited cross-blocking bioactivity to Mal d 1.²²⁵

A nonallergenic birch pollen allergy vaccine, consisting of hepatitis PreS-fused Bet v 1 peptides²²⁸ or derivatives of the Bet v 1 obtained by rational sequence reassembly²²⁹ showed reduced allergenic activity when tested in BAT with basophils from patients allergic to birch pollen. Modification of Bet v 1 into trimer showed a more than 10-fold reduced allergenic activity compared with the rBet v 1 wild-type.²³⁰

BAT can also explore the role of organic compounds of airborne particles in the aggravation of IgE-mediated allergic reactions to aeroallergens. Thus, organic extracts of urban aerosol (of PM2.5 or less) or polycyclic aromatic hydrocarbons from diesel emissions

TABLE 6 Basophil activation test to allergen components in insect venom allergy. Needs list of Abbreviations

Allergen	Molecular allergen	Source	Concentrations	Comparison to extract and/or clinical relevance	Reference
Wasp venom	rVes v 5	Sf9 insect cells	0.1, 200 and 2000 ng/mL; 0.08–1000 ng/mL	Higher sensitivity and specificity than extract	[211, 99, 213]
	rVes v 3	Sf9 insect cells	0.08–1000 ng/mL; 2, 10, 50 and 250 and 1000 ng/mL	Higher activation compared to extract; lower sensitivity and higher specificity than extract	[99, 213, 215]
	rVes v 1	Sf9 insect cells	0.1, 200 and 2000 ng/mL	Lower sensitivity and higher specificity than extract	[211, 213]
	rVes v 2	Sf9 insect cells	0.08–1000 ng/mL	Lower sensitivity and specificity than extract	[213]
	rVes v 2b	Sf9 insect cells	1.6, 8.0, 40, 200, 1000 ng/mL	No basophil activation	[218]
Bee venom	nApi m 1	<i>Apis mellifera</i> bee venom	0.08–1000 ng/mL, 0.001–10 µg/mL	Higher (64) /slightly lower (71,72) activation compared to extract	[212, 219, 220]
	Qdot-labeled nApi m 1	<i>Apis mellifera</i> bee venom; conjugated to Amino (PEG) Quantum Dots or Carboxyl Quantum Dots	0.012–12.0 nM for NQ705 nApi m 1 0.0185–18.5 nM for CQ705 nApi m 1	For amino (NQ) Qdot-labeled nApi m 1 similar activation compared to nApi m 1; for carboxyl (CQ) Qdot-labeled nApi m 1 no basophil activation	[219]
	Mimotopes of Api m 1 epitopes	<i>E. coli</i>	0.01–10 µg/mL	No basophil activation	[220]
	rApi m 2	Sf9 insect cells, High Five insect cells	1.6, 8.0, 40, 200, 1000 ng/mL; 0.1, 1, 10, 100, 1000, 10000 ng/mL	Lower activation compared to extract	[218, 219]
	Qdot-labeled rApi m 2	High Five insect cells; conjugated to Amino (PEG) Quantum Dots or Carboxyl Quantum Dots	0.01–11.0 nM for NQ800 rApi m 2 0.0031–3.1 nM for CQ800 rApi m 2	For amino (NQ) Qdot-labeled rApi m 2 similar activation compared to rApi m 2; for carboxyl (CQ) Qdot-labeled rApi m 2 no basophil activation	[219]
	rApi m 5	Sf9 insect cells	0.08–1000 ng/mL; 2, 10, 50 and 250 and 1000 ng/mL	Higher activation compared to extract	[99, 215]

enhance Bet v 1-induced activation of basophils from birch pollen-allergic individuals.^{234,235}

BP14, the only pollen allergen (cypress) member of the Gibberellin-Regulated Protein (GRP) protein family reported so far, can induce basophil activation in patients with pollen/food-associated syndrome (PFAS) cypress/peach.²³⁶ BP14 is the cross-reactive allergen of Pru p 7 and Snakin-1.²³⁶ Pru p 7 is a predominant cause of severe subtype of Cupressaceae pollinosis underlying cause of severe peach allergy, and Pru p 7 is highly potent in BAT.²³⁷

Grass and weed pollen allergens

Both major grass pollen allergens Phl p 1 and Phl p 5 are showing a high allergenicity and basophil activation in a great majority of grass-pollen sensitized subjects.^{226,227,238} Similarly, a cross-reacting group 2/3 major grass pollen Phl p 2 allergen induces a positive BAT response in correspondingly sensitized subjects.²²¹

BAT is important for the characterization of novel recombinant, hypoallergenic, peptide-based vaccines for grass pollen allergy and has become a major tool for evaluating change in allergenicity when basophils from patients allergic to grass pollen are tested with novel vaccines peptides and/or carriers.^{93,239–241} For instance, basophil activation induced by mix of increasing concentrations of the four major timothy grass pollen allergens (rPhl p 1, 2, 5, and 6) was reduced during recombinant B cell epitope-based vaccine (BM32) immunotherapy of patients with grass pollen allergy.²⁴⁰ Furthermore, rPhl p 5 dependent basophil activation inhibition with SCIT sera demonstrated that immunotherapy-induced allergen-specific IgG antibodies are not long-lasting after treatment discontinuation.²⁴²

In weed pollen allergy, *Parietaria judaica* represents one of the main sources of allergens in the Mediterranean area with Par j 1 and Par j 2 as major allergens.²⁴³ Par j 2 demonstrated a positive response in BAT and resembling the allergenic epitopes of *Parietaria*

judaica pollen. Par j 4 a minor Phl p 7 cross-reactive calcium-binding protein was also positive on the BAT.²⁴⁴

House dust mites and cockroach allergens

BAT was effectively used to characterize the allergenic activity and molecular characteristics of new house dust mite allergens (HDM) Der p 23,²⁴⁵ Der p 18,²⁴⁶ and Der f 24²⁴⁷ and to monitor the change in allergenic activity after genetic engineering and conversion of Der p 1, 2, 5, 7, 21 and/or 23 allergens into hypoallergenic vaccines.^{248–252} Der p 23, which represents a new major HDM allergen, is characterized by high allergenicity comparable with Der p 1, Der p 2, and this was convincingly demonstrated by upregulation of CD203c expression on basophils from HDM allergic patients.²⁴⁸ Basophil activation was also used to assess inhibition of Der p 1 response through cross-linking of FcεRI with FcγRIIb.²⁵³ In a comprehensive scan of 12 molecular HDM allergens compared with HDM extract, symptomatic patients reacted with more molecules than asymptomatic patients. The number of reactive molecules correlated with the area under the curve of the extract BAT response.²⁵⁴ Recombinant cockroach allergen Per a 5, Per a 9, and Per a 10 expressed in insect cells can activate passively sensitized²⁵⁵ basophils.^{255,256} Basophil testing is used as a tool to document the biological activity of those recombinant allergens; however, this approach could benefit from standardization. Additionally, as a minimum, the recombinant protein should be compared with extract from the source organism with 5 relevant allergen concentrations.

Cat, dog, and horse allergens

The response through CD63 and CD203c of 20 cat allergic patients and 19 controls to stimulation with the major allergen Fel d 1 was equivalent and 100% sensitive.²⁵⁶ As CD203c is expressed on resting cells, there is a convention of calculating the stimulation index for this marker rather than using the fraction of activated cells as is done for CD63. BAT was used to characterize recombinant cat albumin Fel d 2, a cross-reactive animal allergen,²⁵⁸ cat lipocalin Fel d 7 and its cross-reactivity with the dog lipocalin Can f 1,²⁵⁹ and a novel cat allergen cat-NCP7, with homology to Can f 7.^{257,260}

For the development of hypoallergenic cat vaccine based on Fel d 1-derived peptides fused to hepatitis B PreS allergenic activity of Fel d 1 and the fusion proteins were compared by using basophil activation tests in patients with cat allergy.²⁶¹ The recombinant fusion proteins exhibited more than 1000-fold reduced allergenic activity in BAT in comparison to Fel d 1.²⁶¹ Recombinant mosaic proteins generated by reassembly of non-IgE-reactive peptides of Fel d 1 similarly showed a strong reduction in allergenic activity.²⁶²

The dog allergen Can f 6 is a major allergen in dog-allergic Chinese children and it demonstrated allergenic activity in BAT.²⁶³ Recently, a panel of recombinant dog allergens (Can f 1–6) was quantified in commercial skin prick test (SPT) solutions of dog extracts, and allergenicity to dog extract was assessed by BAT in three patients. Extensive variations in allergen composition were observed in commercial SPT vials resulting in a patient-dependent ability to activate

basophils.²⁶⁴ Those observations favoring a recombinant approach in the diagnosis of dog allergy, which is quite common in industrialized countries. Among 58 children sensitized to dog dander, basophil testing with dog allergens was as good at identifying children with clinically relevant sensitization to dogs. All patients with dog allergy-related rhinitis or asthma had relevant basophil activation to Can f 1–6 mix, and the four children that were sensitized to Can f 1 but with a negative BAT response to Can f 1–6 mix seem clinically tolerant to the dog. Those BAT data were clinically more relevant as the measurement of IgEs to Can f 1, Can f 2, or Can f 3.

5 – Advantages and limitations

Like any test, the BAT has advantages and limitations, which need to be considered when applying the BAT to clinical practice.^{265,266} For instance, given the practicalities involved in the performance of the BAT currently, it is not feasible to use in all patients needing allergy testing but rather to use it as a second-line test in all patients for whom the initial set of tests, namely skin and specific IgE testing was not possible or was equivocal, before considering referring the patient for a provocation test, which involves the risk of allergic reaction, or before starting immunotherapy. Should automated methods become available, the use of BAT may become a first-line test. Flow cytometry-based BAT has long replaced the first methods to assess basophil activation, such as histamine and leukotriene release, and has become the method of choice as it is more precise and robust than the former methods.

Advantages of the BAT include:

1. High specificity in diagnosis—see previous sections on BAT in food and venom allergy for example.
2. Safety of patients—BAT is safe for the patient, as it does not require *in vivo* exposure to the allergen.
3. Variety of stimulants—almost any material can be tested as long as standardized conditions are used and activity is checked on blood of a nonsensitized control individual if basophils in blood of the patient respond. Many drugs and occupational allergens can be adapted to the test; they are usually added in 10% of the blood volume or in an equal volume.
4. Reproducibility—basophil testing is reproducible for diagnosing allergy²⁶⁷ and assessment of basophil sensitivity as marker of allergy is more reproducible than threshold of allergen provocation.^{268,269}
5. Simple equipment—BAT can be performed on any flow cytometer as limited number of colours is required.

Limitations of the BAT include:

1. Requires fresh blood—BAT needs to be tested preferably within 24 h of blood collection. Blood can be tested at up to 48 hours, but dichotomous negative results must be taken with a grain of salt as they may be false negative. To obviate the

TABLE 7 Basophil activation test to allergen components in respiratory allergy

Allergen	Molecular allergen	Source	Concentrations	Methodological and/or clinical relevance	Reference
Tree pollen					
PR-10-like allergens	Bet v 1	<i>E. coli</i>	10 ⁻⁷ –10 µg/mL; 1 ng/mL; 1–100 ng/mL; 0.31–20 ng/mL; 0.25–100 ng/mL; 0.002–1000 ng/mL; 10 ⁻⁵ –10 µg/ml; 1 µg/mL; 0.1 and 0.3 µg/ml; 0.00001–0.1 µg/ml; 0.005–50 pmol/L; 0.05 pM–0.5 nM	Evaluation of allergenicity of birch pollen sensitisation	[234,235,226, 227,238,228, 229,230]
	Mal d 1		1 µg/mL; 0.25–100 ng/mL; 0.1 and 0.3 µg/ml	Identification of cross-reactive non-sensitizers or partial cross-reactive sensitizers; limited Bet v 1 SLIT bioactivity for Mal d 1	[222, 225, 232]
	Api g 1		10 µg/ml		
	Dau c 1		1 µg/mL		
	Que m 1		0.08–1000 ng/mL	A major allergen from Mongolian oak pollen.	[223]
	Aln g 1		0.25–100 ng/mL	Limited Bet v 1 SLIT bioactivity for cross-blocking of PR-10-like allergens of Fagales pollen	[224]
	Car b 1				
	Ost c 1				
	Cor a 1				
	Fag s 1				
	Cas s 1				
	Que a 1				
	Bet v 1–derived peptides	<i>E. coli</i> ; fused to the hepatitis B surface protein, PreS	0.00001–0.1 µg/ml; 0.005–50 pmol/L	Highly reduced allergenic activity	[228, 229]
	rBet v 1 trimer	<i>E. coli</i>	0.05 pM–0.5 nM	10-fold reduced allergenic activity	[230]
Cypress pollen	BP14	From cypress pollen	5–5000 ng/mL	BP14, the only pollen allergen member of the GRP protein, is positive in BAT of patients with pollen-food syndrome (cypress/peach)	[236]
	Pru p 7 and Snakin-1	Extract of peaches or <i>Pichia pastoris</i>	0.25 pg/mL–2.5 µg/mL; 1–1000 ng/mL	BP14 is cross-reactive with Pru p 7 and Snakin-1; Pru p 7 sensitisation is a predominant cause of severe, cypress pollen-associated peach allergy; Pru p 7 is very potent in BAT	[236, 237]
Grass and weed pollen allergens					
Grass pollen	Phl p 1	<i>E. coli</i>	10 ⁻⁷ –10 µg/mL; 10 ⁻⁵ –10 ug/mL;	High allergenicity and positive basophil activation in a great majority of grass-pollen sensitised subjects; inhibition with SCIT sera	[73, 226] [243]
	Phl p 5		1 µg/ml		[227]
	Phl p 2				
	rPhl p 1 and 5 mix		0.001–10 µg/ml		[238]
	rPhl p 1 and 5 mix				

need for fresh blood, passive sensitization of mast cells lines or basophils from nonallergic donors in place of autologous basophils, i.e., patients' own basophils, can be used.²⁷⁰ An alternative approach is to activate, label, lyse, and fix basophils

at the clinical site, and to analyse them in a centralized flow cytometry service.²⁷¹

2. Nonresponders—10–15% of subjects have nonreleaser basophils (i.e., basophils that do not respond to allergen or the IgE-mediated

TABLE 7 (Continued)

	rPhl p 1, 2, 5 and 6 mix		1, 5, 25 and 125 pg/ml	Monitoring of immunotherapy	[93]
	Phl p 1–derived peptides	E. coli; hepatitis B surface	0.001–1 µg/mL	Highly reduced allergenic	[239]
	Phl p 2–derived peptides	protein, PreS	0.001–1 µg/mL; 0.05 pM – 20 nM	activity	[93] [239]
	Phl p 5–derived peptides		0.001–1 µg/mL; 0.005 pM – 5 nM		[239] [241]
	Phl p 6–derived peptides		0.001–1 µg/mL		[239]
	rPhl p 1, 2, 5 and 6 – derived peptides		0.001–10 µg/ml		[238]
Weed pollen	Par j 2	E. coli	0.01–10 µg/mL	Positive response in BAT	[244]
	Par j 4				
House dust mites	Der p 1	E. coli; natural	0.1–100 ng/ml; 0.04–400 nmol/L; 0.00004–10 µg/mL; 0.1–1 µg/ml	Evaluation of allergenic activity and molecular characteristics of	[245] [250] [252] [253]
	Der p 2		0.1–100 ng/ml; 0.066–660 nM; 1.0 µg/ml; 0.0001–10 µg/ml; 0.32– 5000 ng/ml	house dust mites allergens	[246] [252] [248] [226] [249]
	Der p 5		0.1–100 ng/ml		[252]
	Der p 7		0.1–100 ng/ml		[252]
	Der p 18		0.0001–10 µg/ml		[246]
	Der p 21		0.1–100 ng/ml		[252]
	Der p 23		0.1–100 ng/ml; 0.012–1200 nM; 0.00004–10 µg/mL		[245][251][205] [247]
	Der f 24		1.0 µg/ml		[252]
	Der p 1, 2, 5, 7, 21, 23 mix	E. coli; natural; hepatitis B	0.6–600 ng/ml	Highly reduced allergenic	[248]
	Der p 1–derived peptides	surface protein, PreS	0.04–400 nmol/L	activity	[249] [250]
	Der p 2–derived peptides		0.066–660 nM; 0.04–400 nmol/L; 0.32–5000 ng/ml		[248]
	Der p 23–derived peptides		0.012–1200 nM		[251]
	Der p 1, 2, 5, 7, 21, 23 – derived peptides		0.76–760 ng/ml		[252]
American Cockroach	bPer a 5, iPer a 5	E. coli, insect cells	1 µg/ml	Comparison of sensitised patients and controls	[256, 255, 1530,257]
	Per a 9				
	Per a 10				
Cat, dog, and horse allergens					
Felix domesticus, cat	Fel d 1	E. coli	0.5 µg/ml; 0.01–0.00001 mg/mL	Fel d 1 BAT is clinically highly sensitive; characterization of	[257] [261] [262] [258]
	Fel d 2		0.1 µg/mL	novel cat allergens.	[259]
	Fel d 7		0.001–10000 ng/ml		[260]
	CAT-NPC7		10 µg/mL		[260]
	rFel d 1–derived peptides	E. coli; hepatitis B surface protein, PreS	0.01–0.00001 mg/mL 0.001–10000 ng/ml	Highly reduced allergenic activity	[261, 262] [260]
Canis familiaris, dog	Can f 1	E. coli; not specified	1 µg/ml	High clinical relevance; Can f 6 is a major allergen in dog- allergic Chinese children	[264] [156]
	Can f 6		0.05 – 500 ng/ml		
	Can f 1 - Can f 6 mix				

positive control but only to the non-IgE-mediated positive control) and their results for BAT cannot be interpreted.

- Manual assay requires significant hands-on time—Automated assays are desirable and could circumvent this issue.
- Subjectivity of data analyses—Interpretation of flow cytometry basophil activation is subjective. Attempts to standardize and automate it using artificial intelligence are underway. There are few

allergens for which there is a data-driven clinical threshold for a positive BAT.¹⁷⁶

As flow cytometers become more ubiquitous and basophil testing by flow cytometry becomes more standardized, basophil testing by flow cytometry will become a more accepted method of supporting a diagnosis and of assessing the allergic status of a patient.

6 – Future perspectives

Basophil testing is increasingly used as an *ex vivo* correlate to document the clinical relevance of novel allergens and to characterize the allergenicity of novel recombinant-based immunotherapy vaccines and carriers; however, there is a need to harmonize requirements for this documentation. Basophil testing with recombinant allergens

(either in combination with allergen extracts or alone) can also be used to support clinical diagnosis. Procedures and methodologies been to be defined and harmonized for BAT to be used more widely. This is an exciting field, as recombinant allergens used for basophil testing need less stringent control than allergens used for skin prick testing and therapy.

A06 – *In vivo* testing

Alexandra F. Santos, Peter Korosec, Leticia de las Vecillas, Nikolaos Douladiris, Barbara Ballmer-Weber

Highlights

- The clinical history is the cornerstone of allergy diagnosis and should be combined with the results of allergy tests to confirm or exclude the diagnosis.
- Provocation tests are especially helpful when discrepancies exist between the clinical history and other *in vivo* or *in vitro* test results, to phenotype patients and to monitor specific immunotherapy efficacy.
- Only allergen extracts or fresh produce can be used for *in vivo* testing and up to now no molecular allergens based *in vivo* tests are available.
- The use of recombinant allergens in provocations test seems to improve their accuracy; however, it is an unmet need, which requires further investigations.

1 – Introduction

The cornerstone for an accurate diagnosis and a targeted appropriate treatment of allergic disease is the clinical history.²⁷² Subsequently, allergy testing should be performed to document the presence of allergen-specific IgE. This can be achieved using skin prick testing and/or specific IgE testing. The combination of a history suggestive of allergy, namely of typical IgE-mediated symptoms following specific allergen exposure, with evidence of IgE sensitization to the allergen allows to confirm the diagnosis of allergy.¹⁶⁹ Conversely, a history suggestive of tolerance or the absence of allergic reactivity to the allergen source combined with undetectable allergen-specific IgE allows excluding the diagnosis of allergy. Unclear history and/or discrepancy between history and IgE sensitization to the suspected allergen requires assessment with a provocation test.⁷²

IgE-mediated allergic reactions can be caused by a wide variety of allergens. Although IgE sensitization to an allergen does not equate to clinical reactivity or allergic disease, IgE based tests can be used to identify the culprit allergen. Persistence, severity and coexistence of allergic reactions are often associated with multisensitization. Concurrent irritant triggers, certain infections, and nonallergic disorders often have a similar presentation to allergy and allergy can drive the underlying inflammatory pathology complicating another disorder. Differential diagnosis is, therefore, an important part of the diagnostic process.

This chapter will cover the importance of and key questions to ask during an allergy-focused clinical history and the performance and diagnostic utility of two forms of *in vivo* testing used to support the diagnosis of IgE-mediated allergy: skin prick testing and provocation tests. Separate chapters will cover *in vitro* testing extensively.

2 – Clinical history

A detailed clinical history will provide information on the following important aspects:

- A The type of signs and symptoms suggesting the possible underlying immunological mechanism;
- B The likelihood of allergy being the main driver of the signs and symptoms;
- C The allergen or the allergens as the triggers of the signs and symptoms and drivers of pathology;
- D Identification of possible co-factors or facilitators;
- E Assessment of the severity of disease and prognosis.

As such, the diagnosis of allergic disease begins as first-line approach, with thorough clinical history and physical examination of the patient. [Textbox 9](#) lists the key questions to ask as part of the clinical history.²⁷²

Allergy tests

Specific IgE sensitization can be determined using *in vivo* skin prick tests and /or *in vitro* blood tests, as second line. If there is a mismatch between the history and these primary diagnostic tests, third line tests, such as cellular tests, like the basophil activation test, can be used to assess ex vivo the effector cell response to allergen. If, despite the allergy tests, the diagnosis is unclear, provocation tests (e.g., nasal allergen, conjunctival or bronchial challenge, placebo-controlled, or open food challenge) may be needed to clarify the diagnosis.⁷²

An increasing proportion of patients have unclear clinical history and inconclusive allergen extract tests.^{273,274} In these circumstances, molecular based diagnostics can be considered particularly in the case of patients with complex symptomatology that mainly originates from:

- A Polysensitization to multiple inhalant allergens with overlapping exposure periods to natural and work environment, with graded symptoms. Molecular allergens can be used to efficiently identify genuine sensitization to eliciting allergens, reveal co-sensitization and/or cross-sensitization of closely related or widely different allergens sources and optimize the selection of allergen specific immunotherapy when⁹⁷ needed.
- B sensitization to one or more food allergens with graded severity of symptoms that appears on ingestion of graded quantity and/or procession of food. Molecular allergens can be used to characterize the persistence, the severity and assess the future risk of the reaction in relation to stability and any procession of the offending (food) allergen.⁴⁵
- C Co-sensitization to inhalant and food allergens present with symptoms of unknown aetiology. Molecular allergens can be used to optimize the decision process of provocation tests,

Textbox 9 Aspects to check as part of the clinical history

- Presentation: Which symptoms does the patient present with?
- Timing: How soon after exposure to the allergen do the symptoms develop?
- Likelihood of allergy: To what extent does allergen exposure contribute to the symptoms? Does the patient present with symptoms or conditions other than allergic disease/s?
- Potential mechanism: Does the patient present with characteristic symptoms of allergic disease/s? If so, what is the likely underlying mechanism (IgE, non-IgE-mediated)?
- Consistency: Are the symptoms consistent, i.e., do they develop every time the patient is exposed to the allergen?
- Grading: Are the symptoms of a grading severity, i.e., do they develop graded on exposure to graded quantity of the allergen?
- Seasonality: Do the patient's symptoms worsen during any particular time/season of the year? Are they seasonal or perennial?
- Geography: Do the patient's symptoms correlate with a certain place or geographical area?
- Related allergens: Do the patient's symptoms get worse when in contact with known closely related or widely different allergen sources?
- Other triggers: Do other substances, nonallergens or highly suggestive yet undefined allergens, provoke and/or worsen these symptoms or add new symptoms and of increased severity?
- Potential co-factors: Do another disease, infection, drug intake (i.e., NSAID) or physical activity provoke and/or worsen these symptoms or increase their severity?
- Family context: Does anybody in the patient's family present the same symptoms or any symptoms characteristic of allergic disease/s currently or in the past?

avoiding costly, time consuming, potentially life-threatening reactions and improve allergen avoidance recommendations.⁴⁵

- D Polysensitization to insects' venom allergens present with unclear insect sting history. Molecular allergens can be used to efficiently identify genuine sensitization to eliciting allergens, reveal co-sensitization and/or cross-sensitization to different venom allergens, improve the decision process of insect avoidance recommendations and optimize the selection of venom specific immunotherapy when needed.^{209,1629} Molecular Allergy based diagnostics can thus be used as third line investigation in patients with inconclusive history and allergen extract based tests, before

considering referral for provocation tests⁴⁵ or initiation of a specific immunotherapy. Currently, molecular allergy tests are only available for *in vitro* testing and not for skin or provocation tests and thus will be covered extensively in other chapters.

4 – Skin prick test

Skin prick test (SPT) is a widely available procedure that is usually performed in the physician's office by a qualified healthcare professional.²⁷⁵ SPT consists on the application of allergen extract solution on intact skin followed by puncture using a standardized 1 mm lancet to facilitate the penetration of the allergen through the epidermis into the dermis (Figure 15). If the individual is sensitized to the allergen being tested, this will elicit a wheal and flare reaction at the site. Prior to testing, the skin should be labelled with the different extracts being tested as well as the positive and negative controls, separated by about 1 cm distance to avoid cross-contamination. The positive control is usually a 1 mg/ml histamine solution and the negative control a 0.9% NaCl saline solution. Each control or allergen requires a new lancet and after pricking it is important to clean residual allergen extract/control to avoid contamination. Fifteen minutes later, the results are ready to be read using a ruler and measuring the wheal size diameter. Usually, the wheal diameter is the average of the widest diameter of the wheal and the widest diameter perpendicular to that. The positive control should be at least 3 mm, which is the conventional cut-off for a positive SPT, and the negative control should ideally be 0 mm.⁶⁸

Advantages of SPT compared with serum specific IgE testing are the fact that SPT is inexpensive, provides immediate results, which are evident to patients in clinic, and allows testing with fresh material in addition to allergen extracts. Limitations of SPT are the need for clear skin and to stop anti-histamines a few days prior to testing, being performed by trained skilled healthcare professionals in facilities with equipment and medication required to treat allergic reactions. Systemic allergic reactions of varying degree of severity may result from SPT but are extremely rare.¹⁶⁹ Apart from allergen extracts, fresh produce can also be used for SPT—the so-called “prick-to-prick test” or “modified SPT.” This is particularly important for fruits and vegetables, whose allergens can be labile and get degraded during the extract preparation and therefore can be poorly represented in commercially available allergen extract solutions.²⁷⁶ Using fresh fruits and vegetables allows for more sensitive SPT and for confirmation of allergy in case of sensitization is consistent with the history of allergic reactions to the same food but can induce on the other hand irritation of the skin and false positive results. Using individual allergen molecules could be advantageous regarding specificity and clinical information, but there are limitations in the use of recombinant allergens for SPT.²⁷⁷ Some house dust mites' molecular allergens such as Der f 27 and Der f 29, have been previously used in SPT for research.^{278, 1632} Also, Che a 1, Che a 2 and Che a 3, from *Chenopodium album* and Ani s 1 from *Anisakis simplex*.^{279,1634} Solutions of allergen extracts enriched for certain allergens, such as



FIGURE 15 Skin prick test procedure

palm profilin and peach LTP, can be available commercially and may be helpful in reaching a precise diagnosis in multisensitized patients.²⁸⁰ Molecular allergens from fish have been also tested in a pediatric population. Wild-type Cyp c 1 (wtCyp c 1) has been shown to be a useful standardized allergen for skin testing to diagnose patients with fish allergy.²⁸¹ Recently, a recombinant hybrid molecule including the major grass pollen allergens detected by a positive result in SPT has been shown to be a useful and safe tool for *in vivo* diagnosis of genuine sensitization in children, reducing the test to a single extract.²⁸² Apart from identifying the allergen molecules that are more clinically relevant, the use of molecular allergens for skin testing may also be useful to risk-stratify patients (e.g., sensitization to Ara h 2 or Cor a 9 and 14 posing a higher risk of reaction during challenges) and to detect less allergenic molecules to include in immunotherapy vaccines, after confirming their capacity to induce allergen-specific blocking IgG antibodies.^{277,281,282} Nevertheless, skin testing with recombinant or native purified allergens has not entered clinical routine.

Allergen provocation tests

Provocation tests are often useful to confirm the presence of allergy through the exposure of the patient to a suspected allergen in a medically supervised environment,⁷² particularly when other *in vivo* or *in vitro* tests cannot give a conclusive result and to differentiate between allergic sensitization not leading to allergic symptoms (clinically not relevant sensitization) and clinically relevant sensitization leading to reactivity.²⁸³ Provocation tests allow to identify of phenotypes, culprit relevant allergens and to assess the evolution/improvement of a patient who underwent specific immunotherapy in food and airborne allergies including asthma and rhinoconjunctivitis. These tests also have an important role in research to identify key allergens to use for allergen-specific immunotherapy. Before exposing a patient to a possible harmful substance, a risk stratification must be assessed before the provocation to ensure the safety and the effectiveness of the procedure.²⁸⁴ Guidelines have recently been published about their use in different allergic diseases.^{72,283,1630}

NASAL ALLERGEN PROVOCATION

Nasal provocation can be potentially useful to identify different chronic rhinitis phenotypes including the diagnosis and management of local allergic rhinitis, which is characterized by the absence

of serum specific sIgE or positive SPT to aeroallergens despite ongoing symptoms.¹⁶³³ Individual and standardized lyophilized extracts of *Dermatophagoides pteronyssinus*, *Alternaria alternata*, *Olea europea* and a mix of grass pollen have been used to assess the nasal reactivity to identify clinically relevant allergens to tailor a specific treatment such as allergen immunotherapy.²⁸⁵ Recombinant timothy grass pollen allergens (rPhl p 1, rPhl p 2, rPhl p 5) and recombinant birch pollen allergens (rBet v 1 and rBet v 2) used in skin test and nasal provocation have shown a significant correlation with clinical symptoms, better than serum specific IgE determination.²⁸⁶ For olive pollen allergy, the challenge with the major allergen nOle e 1 increases the specificity of the procedure, compared with a nasal challenge with olive pollen extract.²⁸⁷ Nasal provocations comparing natural and recombinant Bos d 2 allergen have also been applied to determine which allergen is more appropriate for allergen immunotherapy, based on the reactivity of the patients.²⁸⁸ Single molecules, however, are not available for routine nasal provocation testing.

CONJUNCTIVAL ALLERGEN PROVOCATIONS

For conjunctival provocations, the use of different pollen extracts such as ragweed and grass pollen or recombinant molecular allergens such as rBet v1 in an environmental exposure chamber has been shown to reproduce a more natural exposure than the traditional conjunctival allergen challenge in allergic patients.^{289,290,1635} Provocation with component Bet v1 and birch extract found comparable allergenic reactivity of recombinant and natural products.²⁹¹

BRONCHIAL ALLERGEN PROVOCATION

The first allergen used in bronchial provocation was grass pollen in 1873.²⁹² Since then, other allergens such as house dust mites have been used to identify relevant allergens responsible for patients' symptoms.²⁹³ Although it is not a test to diagnose asthma itself, bronchial provocation is important in polysensitized patients to identify the culprit allergen/s, allowing clinicians to use tailored management and patients to implement environment control exposure or even to choose a healthier lifestyle. A trial comparing bronchial provocation of asthmatic patients found comparable reactivity of component Bet v 1 and natural allergen in skin prick test, nasal and bronchial allergen provocation. However, its utility is limited by the potential risk of severe asthmatic reactions. Its use in the diagnosis of occupational allergy has been described with a better

correlation with the hyperreactivity severity than non-specific bronchial challenges.²⁹⁴

ORAL FOOD CHALLENGE

Oral food challenge is an essential tool in the diagnosis of food allergy. Depending on age, patient characteristics and situation demands it can be performed as an open food challenge or as double-blind placebo-controlled oral food challenge (DBPCFC). It is also relevant to perform risk stratification before starting food allergen-specific immunotherapy, to determine the initial allergen dose based on the threshold of allergen required to trigger a reaction, and to monitor its effectiveness.²⁹⁵ Identifying the molecular

pattern of sensitization of a patient allows to recognize subjects at risk of suffering severe reactions such as IgE sensitization to *Arachis hypogea* 2 (Ara h 2) from peanut.²⁹⁶ However, to improve the safety and reliability of food challenges with allergenic molecules, more clinical evidence is needed.²⁶⁸

Based on previous data proving the usefulness of molecular allergens in *in vitro* and *in vivo* tests to increase the accuracy of the allergy diagnosis, provocation with molecular allergens seems to be more useful than challenges with the whole extracts. However, these molecules are not yet available for routine diagnosis and more research is needed to better standardize these extracts, which differ from those used for *in vitro* testing.²⁹¹

A07 – Basic and theoretical aspects of allergens

Luis Caraballo, Paolo M Matricardi

Highlights

- Allergens are defined as molecules inducing and binding specific IgE antibodies
- Various allergens have the capacity to stimulate the innate response before inducing IgE
- Cohort studies show the development of polymolecular sensitization—“molecular spreading”
- Initiator molecules from different sensitization patterns are considered as the optimal targets for allergen immunoprophylaxis

1 – Introduction

Like other biomedical sciences, experimental allergology is advancing at great speed. Since the first edition of the EAACI Molecular Allergology User's Guide, important discoveries have been made about the pathophysiological mechanisms of the allergic response and the properties of allergens, which force us to reflect on general theoretical concepts in the field. In this chapter, we will discuss some aspects of allergens on which diverse opinions have been expressed for many years and have to do with ideas and hypotheses that support much of current experimental and clinical work.

2 – The allergen concept

Definitions are short expressions of concepts, which in turn are based on current knowledge. Traditionally, allergens have been defined as those molecules inducing and binding specific IgE antibodies; however, one of the most important recent advances in experimental allergology has been the recognition of the inflammatory capacity of various allergens (in addition to proteases) by stimulating the innate response before inducing IgE.^{40,55} In fact, this has promoted a great change in our mentality regarding the origin of the allergic responses, currently focused on the epithelium and its pattern recognition receptors (PRR), the rapid production of alarmins, damage-associated molecular patterns (DAMPs) and proinflammatory cytokines that seem to be necessary for the development of a type 2 response. Important questions arise from these findings: Should we broaden the concept of allergen? Are there allergens that act entirely without the involvement of IgE? Will these be able to induce respiratory symptoms on their own? Are there phylogenetic equivalents of this type of immune response? Although there are no conclusive answers to these questions, there are reasons to believe that the allergen concept should include other properties in addition to IgE-binding.⁵⁵

Some evolutionary studies support the idea that prior to the existence of IgE in mammals, some stimuli (for example, bacterial toxins) could elicit an allergic-like inflammatory response, including hypersensitivity and shock reactions in fish.²⁹⁷ Teleost in general, dating back more than 300 million years, have several genes that code for components of the Th2 response,²⁹⁸ as well as effector cells (mast cells, eosinophils, and basophils) that are activated against certain antigenic stimuli in a similar way to those of mammals,²⁹⁹ which suggests, at least since the appearance of these organisms, that an immune response similar to what we now know as allergic has occurred. Th2 lymphocytes, which probably predate IgE,³⁰⁰ are an important source, along with type 2 ILCs, of IL-4 and IL-13. Among alarmins, HMGB-1 is quite conserved and orthologs have been found in *C. elegans*,³⁰¹ suggesting that this type of almost innate and immediate cellular response could be present before mammals. In addition, though IL-33 has only been found in mammals,³⁰² its specific receptor ST2 appears earlier in the evolutionary ladder and has been detected in birds and fish,³⁰¹ which is similar to what happened with the IgE and its high-affinity receptor, since the latter is in cells of the innate response (such as mast cells) much before than this immunoglobulin.³⁰³

Thus, some mechanisms of innate allergic inflammation that are currently observed recapitulate processes from innate immunity phylogeny. Considering all the above, it seems that there is no theoretical justification for naming as allergens only those molecules that induce and bind IgE. Perhaps if, hypothetically, in the future this were not a criterion, other molecules that trigger an allergic reaction could be discovered and our extent about what is allergy would be broader. For now, considering the recent progresses in molecular allergology and precision medicine, it has been proposed that inducing specific IgE (allergenicity) is not the only property for being an allergen but also the capacity of inducing inflammation (allergenic activity).^{24,55} Therefore, classifying allergens as “major” and “minor,” according to the frequency and/or the strength of IgE binding is theoretically incorrect, useless and confusing. Of course, as has been well documented with allergen extracts, not all purified components are expected to have the same clinical impact, and this is an important aspect that has to be tested in different ways.⁵⁵ Whatever it is, all of them are allergens, and are important in terms of personalized allergology and should be named just “allergens”.²⁴

3 – Why is a molecule an allergen?

This is one of the main interrogates of allergology and the answers have been guided (both theoretically and experimentally) by two general approaches. One is based on the search for molecular intrinsic properties that could make them allergens. The other is centered on the search for genetic variants that determine an allergic response to the molecules. Looking for common patterns among related families of allergens has been taken as evidence of intrinsic allergenic properties.²⁵ On the other hand, common patterns among allergens

from distant species have been supporting the hypothesis around the origins of allergens and their IgE-binding.³⁰⁴ Interestingly, so far no “intrinsic property” that makes a molecule an allergen has been discovered; similarly, except for genetic variants determining allergic reactions to some drugs, variants that clearly define the allergic response to common allergens, confirmed with functional studies, have not been found. That a molecule is an allergen is the result of a process influenced by a great number of factors but determined by the genetic background of the immune response. Therefore, the general theoretical background of the “genetic point of view” of the existence of allergens will be examined.

The analysis will be focused not only on allergenicity but also on the allergenic activity. Although it is not always recognized, the existence of antigens in general, including allergens, depends on the existence of the immune response.³⁰⁵ As well as other phenotypes the immune response is under genetic control and is highly polymorphic. Therefore, theoretically, any molecule can be an allergen if it finds the appropriate genotype, that is the set of genetic variants in the genome of a person. For that reason, the same molecule, that is inhaled by everybody in a defined environment, even within a family, is an allergen for some of them and just an antigen for others. Those “susceptible” persons are believed to have a combination of genetic variants (a genotype), which conform a cellular/molecular scenario making the induction of type 2 responses easier or lack variants that exert the opposite effect. The clinical name of this phenotype is atopy. Then it could be said that atopic persons define the existence of allergens. It is known that other factors also influence the intensity of the allergic response, some belonging to the molecule itself and others to the host and the environment,²⁴ but, again, their influence is exerted only on the genetically susceptible individuals. For example, the protease activity of Der p 1 can make it more allergenic, but if this property were defining its allergenicity, the entire exposed population would be allergic to it. In contrast to toxins, to which most people are genetically susceptible, allergens affect only a small percentage of the population. Allergen properties such as abundance and stability (e.g., thermostable food allergens) influence allergenicity because they are associated with greater exposure and more possibilities to get in contact with genetically susceptible individuals. If we speculate about the level of genetic control, we will find that allergenicity is expected to be defined by a less complex genotype than allergenic activity and the latter by a less complex genotype than an allergic disease. The genetic polymorphisms that could define both phenotypes (allergenicity and allergenic activity) range from the first contact with the epithelium, the antigenic recognition and processing to inflammatory cytokine production pathways, including those genes that intervene in the innate response. The expression of these polymorphisms is modified by several mechanisms such as epigenetic pathways and gene–gene interactions. Therefore, discovering the genetic basis of allergenic activity or even allergenicity is not an easy and straightforward task. It needs several approaches and collaborations between groups working on allergy and genetics. This will be very helpful because studying genetic mechanisms not only can explain the origin of allergen activity

but also the pathophysiology of allergy and allergic diseases. Also, defining the mechanisms of how allergens and the environment act in the genetically susceptible population would help to understand the genetic control of the immune response.

4 – Initiatory allergen molecules

Atopy is still an enigma, not only because of its complex genetic roots but also because of its poorly defined mechanisms. Consequently, its definition ranges from “the hereditary predisposition to react with IgE” to “the hereditary predisposition to mount a type 2 response” to environmental molecules. Therefore, in clinical and experimental settings, atopy is evaluated by looking at IgE production, usually as a final outcome. However, the process of developing the atopy phenotype involves more than IgE, as has been revealed by the following interesting clinical works.

An age-related increase in the number of allergenic molecules recognized by IgE antibodies has been observed in cross-sectional studies in patient populations, where this number is greater in older patients.³⁰⁶ So far, several birth cohort studies following individual patients since the early years of life have prospectively examined their evolution of IgG and IgE responses to allergen molecules. Specifically, the German Multicenter Allergy Study (MAS), an extensive European birth cohort on atopic diseases, provides insight on the onset and evolution of IgE responses in atopic versus healthy children, as well as on the humoral state prior to the manifestation of IgE or allergic symptoms. Serologic analyses taken from both healthy and atopic children revealed that both groups present a broad repertoire of IgG antibodies to a wide array of allergen molecules already at age 2.³⁰⁷ The intensity and frequency of these “normal” IgG responses differ according to the allergen group, with the highest being animal food allergens, intermediate toward vegetable food allergens, and only minimal to airborne allergens. Of note, a stronger and more frequent IgG response is shown by atopic children, when comparing to their nonatopic peers.³⁰⁷

A second type of “atopic” IgG response was uncovered when studying the IgE response to Bet v 1 and other PR-10 molecules. This response, directed against airborne allergens, was observed to be persistent and accompany IgE production against the same molecule, which led to the assumption that IgE response to Bet v 1 in children with birch allergy represents a broader abnormal humoral response involving IgG antibodies directed to the same antigens. This concept was corroborated in a broader study, which, additionally, showed that the “default” IgG response to major allergenic molecules becomes stronger and persistent in atopic subjects with IgE responses to the same molecules from mites, pollen, or moulds, thus becoming a sort of “atopic” IgG response.³⁰⁸

Various patterns of evolution following the beginning of an IgE response have been described in several cohorts. Within the MAS cohort, subsets of children showed a sequential broadening of the IgE response to *Phleum pratense* molecules. This broadening consisted of a progression from an initial monomolecular through an

oligomolecular and towards a polymolecular sensitization pattern, so that it could be defined as “molecular spreading” (Figure 16).^{95,309} Interestingly, it was also observed that an initial IgE response is directed against Phl p 1 in almost all grass pollen allergic children, making it a sort of starter or “initiator molecule” of this IgE response. Only a small number of patients developed a full-scale polymolecular response to all 8 allergenic molecules of *P. pratense*. This molecular spreading often begins even in the preclinical stages of sensitization. IgE against Phl p 1 has been observed up to 5 years before the child starts presenting the first allergic symptoms.³¹⁰

A quite similar process has been described in the MAS cohort children sensitized to *D. pteronyssinus*.³¹⁰ Sensitization started against Der p 1 and/or Der p 2 and/or Der p 23 (defined as group A molecules); expanded to Der p 4, Der p 5, Der p 7, and Der p 21 (group B molecules); and eventually progressed to Der p 11, Der p 14, Der p 15, Der p 18, and clone 16 (group C molecules). This evolution has been defined as the “ABC march” of mite allergy (i.e., molecular spreading of the IgE repertoire against *D. pteronyssinus* allergens).²⁸ Moreover, an association was observed between several features and a broader polymolecular IgE sensitization pattern, such as early IgE sensitization onset, parental hay fever, and greater exposure to mites. Another curious conclusion was the correlation between participants reaching the broadest ABC IgE sensitization stage and a significantly greater risk of mite-related allergic rhinitis and asthma, not observed in the monomolecularly sensitized participants. Finally, IgE sensitization to Der p 1 or Der p 23 at 5 years of age or less in healthy children predicted asthma at school age.³¹⁰

The Manchester Asthma and Allergy Study (MAAS) showed a similar trend within 235 children whose sera were tested for IgE

to Timothy grass pollen and mite allergens.³¹¹ Three sensitization slopes towards mite allergy were identified among children aged 5 to 11 years: group 1 sensitization (involving Der f 1 and Der p 1), group 2 (Der f 2, Der p 2), and complete mite sensitization (both). Children with group 1 and complete mite sensitization trajectories had a significantly increased risk for asthma, eczema, and rhinitis, but the highest risk for asthma (odds ratio, 7.15; 95% CI, 3.80–13.44) was within the subjects of the complete mite sensitization group. Regarding the grass sensitization, a molecular progression of the IgE response similar to molecular spreading in MAS participants was observed. A correlation between an early onset of IgE response to grass molecules and asthma along with diminished lung function was observed, as well as between a late onset and allergic rhinitis.³¹¹

In the Swedish Children, Allergy, Milieu, Stockholm, Epidemiology (BAMSE) study, sensitization to Fel d 1 and Can f 1 in childhood, as well as polysensitization to allergen molecules of either cat or dog predicted cat and dog allergy cross-sectionally and longitudinally substantially better than simply IgE to cat or dog extract.³¹² The onset and molecular profile of the IgE responses in food allergic patients during childhood and adolescence appears to be crucial, as shown by the BAMSE population-based birth cohort. Two distinct phenotypes of peanut allergy development before adulthood have been identified. The first is the association between early onset of sensitization to Ara h 2 and an increased risk of systemic reactions after peanut exposure, and the second is, starting later in childhood and being related to Ara h 8, goes along with no systemic reactions after peanut ingestion.³¹³ After expanding the data analysis to the whole set of IgE results against 132 allergen molecules, 4 risk molecules were additionally identified, to which an IgE response was

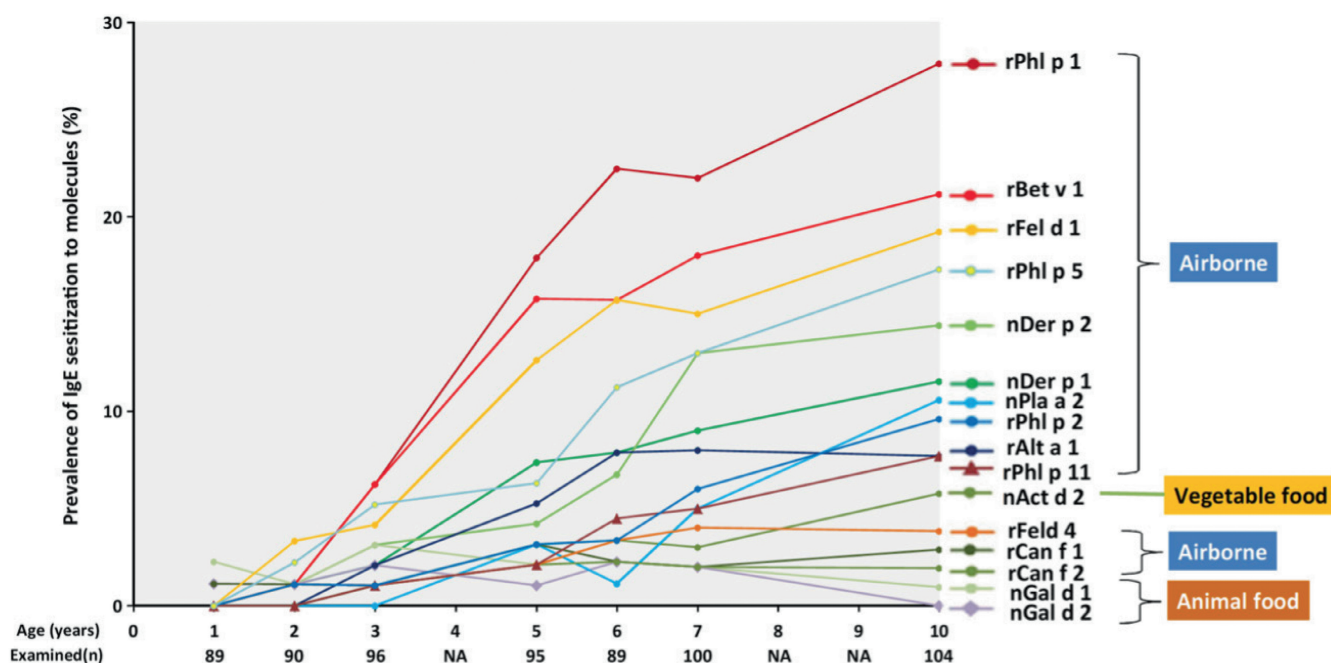


FIGURE 16 Evolution of the prevalence of IgE responses to 16 allergen molecules from 1 to 10 years of age (n = 104). The prevalence of IgE sensitization (≥ 0.3 ISU) to the 16 allergen molecules by age at follow-up is shown. The number of participants examined at each follow-up is reported under the x-axis. NA, not applicable (no blood drawn at this follow-up).

associated with an increased risk of asthma, allergic rhinitis, or both, namely Ara h 1 (peanut), Bet v 1 (birch), Fel d 1 (cat), and Phl p 1 (grass). The previously discussed results regarding airborne molecules could be replicated within the MAAS cohort, adding Der f 2 (dust mite) and Phl p 5 (grass) as disease predictors.³¹³

This uncovered understanding of the progressive molecular spreading of the immune response, especially to airborne allergens, led to hypothesize that immunologic intervention (AIT) should ideally be anticipated, as it might prevent the development of more

complex and strong IgE responses.⁹⁵ The initiator molecules—Phl p 1 for grass pollen, Bet v 1 for birch pollen, Der p 1, Der p 2, and Der p 23 for mites, and Fel d 1 for cat—are thought to be optimal targets for allergen immunoprophylaxis (AIP) aimed at preventing the onset of allergic rhinitis and asthma in children during a preclinical sensitization stage.^{95,309} An initiating molecule has been defined as “The allergenic molecule within an allergenic source responsible for induction of the first IgE antibody response to that allergenic source”.⁹⁵

A08 – Allergen families and databases

Christian Radauer, Gabriele Gadermaier, Heimo Breiteneder

Highlights

- Proteins that share a common evolutionary origin—which is reflected primarily by their similar sequences and structures—are grouped into families. Families with a common origin are grouped into superfamilies.
- Very few of the more than 19,000 protein families as described by the protein family database Pfam harbor allergens.
- Most proteins that are described as allergens can be classified roughly into 30 to 40 protein families.
- Allergen databases make curated information available on allergen nomenclature, allergen structures, allergen protein families, and the risk of allergen cross-reactivity, or offer noncurated extensive collections of information on allergens.

1 – Introduction

A protein family is a group of proteins that share a common evolutionary origin, which is reflected primarily by their similar sequences and structures but often also by similar biochemical functions and physico-chemical properties (Figure 17). Moreover, in most cases common protein family membership is a prerequisite for immunological cross-reactivity. The current version 34.0 of the Pfam (protein family) database (<https://www.ebi.ac.uk/interpro/>) describes 19,179

protein families.³¹⁴ Evolutionarily related families are grouped together into superfamilies—called clans in Pfam—(e.g., the prolamin superfamily). As a consequence of diversification during evolution and as the phylogenetic distance increases, the members of different families within a superfamily possess only moderate to low levels of primary sequence identities and little to no immunological cross-reactivity.

Very few protein architectures give rise to allergenic proteins and thus allergens are only found in a rather limited number of protein families. The AllFam allergen family database (<http://www.meduniwien.ac.at/allfam/>; version of 2017-03-07) assigns all presently known allergens to 216 (1.6%) of the then 16,306 Pfam families. Proteins that are described worldwide as the most important allergens can be classified into roughly 30 to 40 protein families. However, it has to be emphasized that the vast majority of proteins in any given family or superfamily are nonallergenic. The most important families and selected allergenic member proteins are discussed here (Table 8).

Our understanding why exactly these types of proteins are able to trigger Th2-dominated immune responses is incomplete. Allergenic proteins that are able to sensitize predisposed individuals initiate both innate and adaptive immune responses (see chapter A02). Such proteins are recognized by epithelial cells and dendritic cells that produce signals to polarize the immune response towards a Th2 phenotype. It has been shown that the innate immune system plays an important role in the decision whether a protein will be treated as an allergen by the organism.^{315,316} It is highly likely that allergenic proteins possess molecular features that enable them to activate the pattern recognition receptors of innate immune cells to induce a Th2 polarization of the ensuing immune response. These

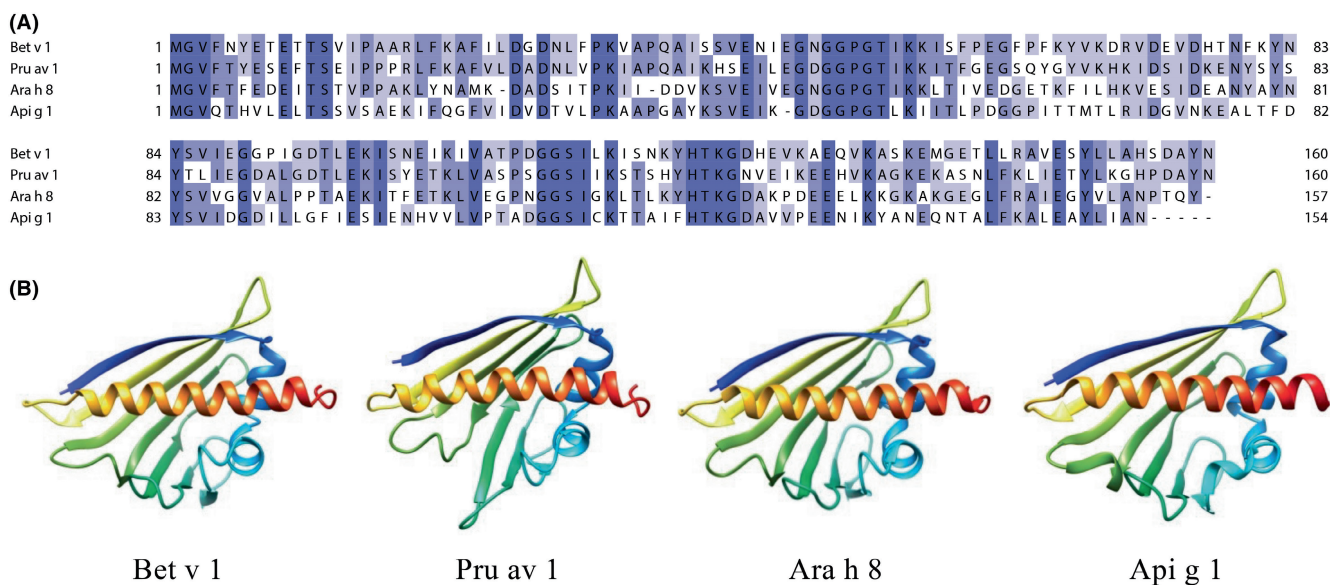


FIGURE 17 The Bet v 1 family as an example of a protein family. Sequence alignment (A) and structures (B) of four representative allergenic members. Bet v 1 is from birch pollen, Pru av 1 from cherry, Ara h 8 from peanut, and Api g 1 from celery.

TABLE 8 Protein superfamilies and families that contain the highest numbers of allergens in descending order. Data were extracted from the AllFam database (<http://www.meduniwien.ac.at/allfam/>).

Superfamily	Number of allergens	Family	Allergen sources
Prolamin	91	Cereal prolamin	Grains of cereal grasses
		Bifunctional inhibitor	Grains of cereal grasses
		2S albumin	Tree nuts, legumes (e.g. peanut), seeds
		Non-specific lipid-transfer protein type 1	Fruits, tree nuts, peanut, vegetables, cereal grains, tree and weed pollen, latex
		Non-specific lipid-transfer protein type 2	Fruits, vegetables, peanut
EF-hand	74	Polcalcin	Tree, grass, and weed pollen
		Parvalbumin	Fish
		Sarcoplasmic Ca-binding protein	Shellfish, insects
		Troponin C	Mites, cockroaches, shellfish
		Myosin light chain	Mites, cockroaches, shellfish
Tropomyosin-like	64	Tropomyosin	Crustaceans, mollusks, the fish parasite <i>Anisakis simplex</i> , mites, cockroaches
Profilin-like	53	Profilin	Tree, grass, and weed pollen, fruits, vegetables, latex
Cupin	37	Vicilin	Tree nuts, peanut, legumes, seeds
		Legumin	Tree nuts, peanut, legumes, seeds
Bet v 1-like	29	Bet v 1	Fagales tree pollen, fruits, vegetables, legumes, tree nuts
Calycin	27	Secreted lipocalin	Mammals, milk
		Cytoplasmic fatty acid binding protein	Mites
		Triabin	Insects
Double-psi beta-barrel	26	Expansin	Grass pollen
		Kiwellin	Kiwifruit
		Barwin-like	<i>Hevea brasiliensis</i> (natural rubber latex), turnip
CAP superfamily	32	Venom antigen 5	Hymenoptera venoms
		Plant pathogenesis-related protein (PR)-1	Pollen, fruits
Pectate lyase-like	23	Pectate lyase	Pollen from Cupressaceae and Asteraceae
		Polygalacturonase	Pollen
		Pectinesterase	Pollen, kiwifruit
		Ole e 1-like	Pollen
Transthyretin	16	Ole e 1-like	Pollen
Cysteine peptidase clan CA	13	Papain-like cysteine protease	Mites, fruits

features include (i) the ability to bind lipids and to activate Toll-like receptors (TLRs)—shown for Der p 2 from house dust mite³¹⁷ and for Fel d 1 from cat,³¹⁸ (ii) the ability to bind other cell surface or soluble pattern recognition receptors thereby modulating innate immune responses—shown for group 13 mite allergens that interact with serum amyloid A,³⁸ (iii) the presence of glycosylation and thus the ability to bind to C-type lectin receptors—shown for allergens from house dust mites, pollen and peanut,^{319,1647,1648} or (iv) the presence of protease activity, which allows the activation of the protease-activated receptor PAR-2—shown for Der p 3 and Der p 9 from house dust mite.³²⁰

2 – The most important allergen containing protein families

2.1. Prolamin superfamily

The prolamin superfamily derives its name from the alcohol-soluble proline- and glutamine-rich storage proteins of cereal grains. Members of this superfamily are characterized by the presence of an α -helical globular domain. This domain contains a conserved pattern of cysteine residues that form three to five intra-molecular disulfide bonds. Apart from the conserved cysteine pattern, only little sequence similarities exist between members of different families.

Members of the prolamin superfamily include the cereal prolamin seed storage proteins (gliadins and glutenins) and several families of disulfide-rich small proteins including the bifunctional inhibitors, the 2S albumin seed storage proteins, and the non-specific lipid transfer proteins (Figure 18).

Cereal prolamins are seed storage proteins that are exclusively found in the grains of cereal grasses. In contrast to the low molecular weight members of the superfamily, the α -helical domain of the cereal prolamins has been disrupted by an insertion of repetitive sequences.³²¹ Gliadins and glutenins represent the members of the cereal prolamin family. Gliadins are soluble in alcohol and are classified into α/β -, γ -, and ω -gliadins. Glutenins are polymeric proteins that are held together by interchain disulfide bonds. They are divided into high and low molecular weight groups.³²²

Like the cereal prolamins, the bifunctional inhibitors are only present in cereal grains. These allergens sensitize either via the respiratory tract by inhalation of the flour or via the gastro-intestinal tract by eating foods that contain wheat, barley or rice. The bifunctional inhibitors are 12 to 16 kDa proteins that are held together by 4 to 6 disulfide bonds.³²³ Monomeric, dimeric and tetrameric forms are distinguished according to the degree of oligomerization of their subunits. They are the major cause of baker's asthma but also play a role as plant food allergens.³²⁴

The 2S albumins are a major group of plant seed storage proteins. Most 2S albumins are synthesized as single-chain proteins that are subsequently cleaved into a small and a large subunit. Both subunits are held together as compact α -helical molecules by 4 to 5 disulfide bonds.³²⁵ Many of the important seed and tree nut allergens are 2S albumins.

Nonspecific lipid transfer proteins (nsLTPs) have been suggested to mediate the transfer of phospholipids between vesicles and membranes. However, plants use the three-dimensional scaffold of the nsLTPs in various ways and many nsLTPs play a role in plant defense

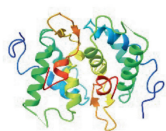
against fungi and bacteria or in the response to abiotic stress. nsLTPs are typically found in high concentrations in epidermal tissues of plant food. The majority of allergenic representatives belongs to nsLTP type 1 (~10 kDa) while recently some members of the type 2 (~7 kDa) were described. Allergenic nsLTPs are highly resistant to thermal and enzymatic digestion³²⁶. They are major allergens of fruits from the Rosaceae family. In addition, allergenic nsLTPs are present in nuts, seeds, vegetables, and *Hevea brasiliensis* (natural rubber latex). Besides their presence in plant foods, nsLTPs are also expressed in pollen of weeds, olive, and plane tree.

- Wheat contains several allergenic cereal prolamins. Tri a 19 is an ω -5-gliadin, Tri a 21 an α/β -gliadin, and Tri a 26 a high molecular weight glutenin from wheat (see chapter B16).
- Hor v 15 is a monomeric α -amylase inhibitor from barley. Tri a 28 is a dimeric and Tri a 29 a tetrameric α amylase inhibitor from wheat (see chapter B16).
- Allergenic 2S albumins include Ara h 2 and Ara h 6 from peanut, Ber e 1 from Brazil nut, Cor a 14 from hazelnut, Jug r 1 from English walnut, Ses i 1 from sesame seeds, and Sin a 1 from yellow mustard (see chapter C08).
- Rosaceae fruit type 1 nsLTPs include Mal d 3 from apple and Pru p 3 from peach. Representative allergenic type 1 nsLTPs from tree nuts are Cor a 8 from hazelnut and Jug r 3 from walnut. Pollen nsLTPs include Pla a 3 from plane tree and Art v 3 from mugwort. Zea m 14 and Tri a 14 are the nsLTPs from maize and wheat. Can s 3 is the nsLTP from Indian hemp (see chapter C03).
- Allergenic type 2 nsLTPs were identified in tomato (Sola l 6), celery tuber (Api g 6) and peanut (Ara h 16).

2.2. EF-hand superfamily

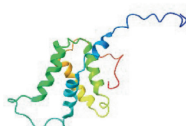
A wide range of calcium-binding proteins share a conserved motif consisting of a 12 residue calcium-binding loop flanked on both sides

Bifunctional inhibitors



Tri a 28

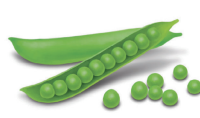
2S albumins



Ara h 6



Cereal grains



Legumes

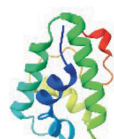


Tree nuts



Other seeds

Non-specific lipid transfer proteins



Pru p 3



Fruits



Tree nuts



Legumes



Cereal grains



Weed pollen



Tree pollen

FIGURE 18 Distribution of allergenic members of the prolamin superfamily. The representative structures are Tri a 28, the dimeric α -amylase inhibitor from wheat (PDB: 1hss), Ara h 6, a 2S albumin from peanut (PDB: 1w2q), and Pru p 3, the type 1 nsLTP from peach (PDB: 2alg)

by an α -helix of 12 residues in length.³²⁷ The term EF-hand derives from the nomenclature of carp parvalbumin, which possesses 6 α -helices, named A to F. These helices are paired to form the calcium-binding motifs, which are now referred to as EF-hands after the third of those pairs, which folds into a structure prototypical for this motif. The biological functions of EF-hand proteins include signaling and calcium buffering or transport. Allergenic members of the EF-hand superfamily are found mostly in animals with the exception of the plant-specific polcalcins (Figure 19).

Polcalcins are 9 kDa calcium-binding pollen proteins of unknown biological function. While regular polcalcins contain two EF hand domains, several polcalcin-related allergens with three or four EF hand domains have been described.³²⁸ Polcalcins were shown to be minor albeit highly cross-reactive allergens identified in pollen from diverse plant families (see chapter C06).

Parvalbumins are 12 kDa proteins that contain two EF hand domains. They are found in fast-twitch muscle fibers of vertebrates and bind calcium ions during muscle relaxation. Parvalbumins from fish and amphibians are major food allergens eliciting IgE responses in most fish-allergic individuals (see chapter C11).³²⁹

The invertebrate 20-22 kDa sarcoplasmic calcium-binding proteins (SCPs) are cytosolic calcium buffers that are characterized by

four EF-hand signatures of which two or three are functional.³³⁰ SCPs are the functional analogs of parvalbumins in invertebrate fast-twitch muscle. They promote rapid muscle relaxation by facilitating Ca^{2+} translocation from myofibrils to the sarcoplasmic reticulum.³³¹

Troponin Cs, 18-21 kDa proteins with four EF-hand Ca^{2+} binding domains, are part of the macromolecular complex composed of troponins, tropomyosin, actin and myosin, and is specifically involved in the regulation of muscle contraction³³², while parvalbumin promotes rapid relaxation through translocation of Ca^{2+} from troponin C into the sarcoplasmic reticulum via a Ca^{2+} pump.³³¹

Myosin light chains (MLCs) are subunits of myosins, motor proteins that play a role in muscle contraction and other motility processes in eukaryotic cells. The myosin molecule is a hexameric complex made up of two heavy chains and two pairs of calcium-binding light chains.³³³ Myosin light chains contain two Ca^{2+} -binding EF-hand motifs.

- Allergenic 2 EF-hand polcalcins include the monomeric Bet v 4 from birch and the dimeric Phl p 7 from timothy grass and Che a 3 from white goosefoot.
- Allergenic 4 EF-hand polcalcin-like proteins are Bet v 3 from birch, Amb a 10 from ragweed and Ole e 8 from olive pollen.

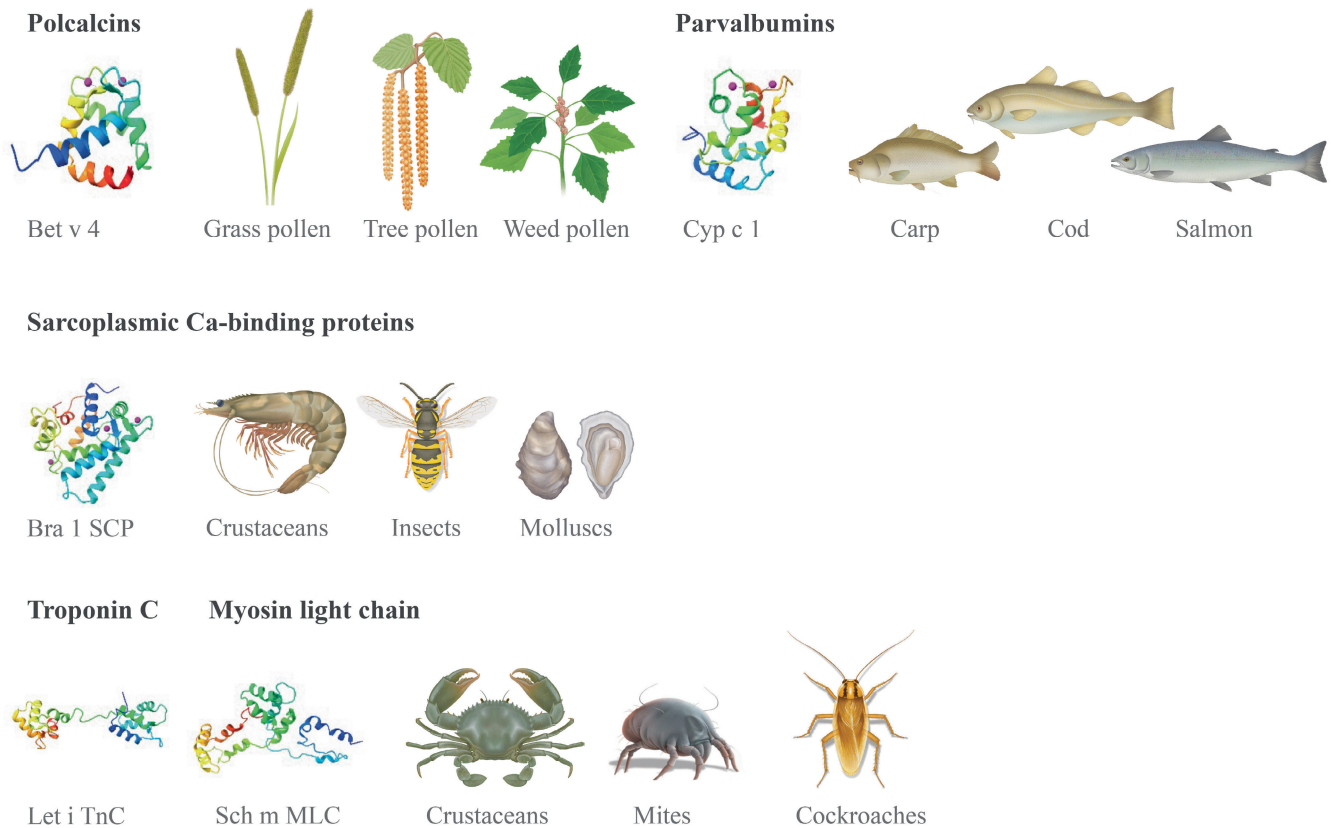


FIGURE 19 Distribution of allergenic members of the EF-hand superfamily. The representative structures of allergens are Bet v 4, the polcalcin from birch pollen (PDB: 1h4b) and Cyp c 1, the parvalbumin from carp (PDB: 4cpv). For the other families, representative structures of nonallergenic proteins are shown: Bra I SCP, a sarcoplasmic Ca-binding protein from amphioxus (*Branchiostoma lanceolatum*; PDB: 2sas), Let i TnC, a troponin C from water bug (*Lethocerus indicus*; PDB: 2jnf), and Sch m MLC, the myosin light chain from *Schistosoma mansoni* (PDB: 3jax). Bound calcium ions are represented by pink spheres. No structures of allergenic EF-hand superfamily members other than polcalcins and parvalbumins have been described.

- Allergenic parvalbumins include Gad m 1 from Atlantic cod, Sal s 1 from Atlantic salmon, and Cyp c 1 from carp.
- Allergenic SCPs have been described in shrimps (e.g., Lit v 4—white shrimp), crabs (e.g., Scy p 4—mud crab), insects (e.g., Aed a 5—yellow fever mosquito), and mollusks (e.g., Cra a 4—Pacific oyster).
- Allergenic troponin C proteins are found in arthropods including crustaceans (e.g., Hom a 6—American lobster), mites (e.g., Der p 39—house dust mite) and cockroaches (e.g., Bla g 6—German cockroach). Allergenic myosin light chains are found in arthropods such as crustaceans (e.g., Scy p 3—mud crab), mites (e.g., Der p 26—house dust mite) and cockroaches (e.g., Bla g 8—German cockroach).

2.3. Tropomyosin-like superfamily

Tropomyosins are present in muscle and nonmuscle cells. In striated muscle, they mediate the interactions between the troponin complex and actin to regulate muscle contraction. Tropomyosin is an α -helical protein that forms a coiled-coil structure of two parallel helices containing two sets of seven alternating actin-binding sites. Tropomyosins were identified as animal food allergens in crustaceans, mollusks, and the fish parasite *Anisakis simplex*.³³⁴ Tropomyosins were also identified as respiratory allergens in arthropods (mites, cockroaches). Tropomyosin sequences are highly conserved, which explains the frequent cross-sensitization among tropomyosin-containing allergen sources (see chapter C05).³³⁵ Pen i 1 from Indian prawn, Bla g 7 from German cockroach, and Der p 10 from house dust mite are well-known allergenic tropomyosins (Figure 20).

2.4. Profilin-like superfamily

Profilins are small cytosolic proteins that are found in all eukaryotic cells. They bind to monomeric actin and various other proteins, thus regulating the dynamics of actin polymerization during processes

such as cell movement, cytokinesis, and signaling. Profilins from higher plants are highly conserved showing amino acid sequence identities of >75% even between members from distantly related organisms.³³⁶ Due to extensive IgE cross-reactivity, extract-based diagnosis can be hampered by clinically irrelevant profilin reactivity. However, profilin sensitization is considered a risk factor for pollen-associated food allergy.³³⁷ Profilins are heat and digestion labile, but co-factors like antacids and fasting as well as damage of the oral mucosae may facilitate allergic food reactions.^{338,339} No substantial cross-reactivity between plant and human profilins has been shown so far (see chapter C01).

Allergenic profilins include Phl p 12 from grass pollen, Art v 4 from mugwort pollen, Bet v 2 from birch pollen, Ole e 2 from olive pollen, Cit s 2 from orange, Cuc m 2 from melon, and Mus a 1 from banana [Figure 21].

2.5. Cupin superfamily

The cupins are a large and functionally immensely diverse superfamily of proteins whose evolution can be followed from bacteria to eukaryotes including animals and higher plants. Cupin proteins are currently classified into 66 protein families. The largest families of bicupins (i.e., proteins that contain two cupin domains) are the 7/8S and 11S seed storage globulins that are the major components of plant seeds. They are important sources of proteins for the human diet but are also major allergens (see chapter C08).^{341,1649}

7S globulins or vicilins are homotrimeric proteins of about 150 to 190 kDa. Their detailed subunit compositions vary considerably due to differences in proteolytic processing and glycosylation of the monomers. In mature 11S globulins (legumins), two trimers associate to form hexameric proteins (Figure 22).

- Allergenic vicilins include Ara h 1 from peanut, Gly m 5 from soybean, Jug r 2 from walnut, and Ses i 3 from sesame.

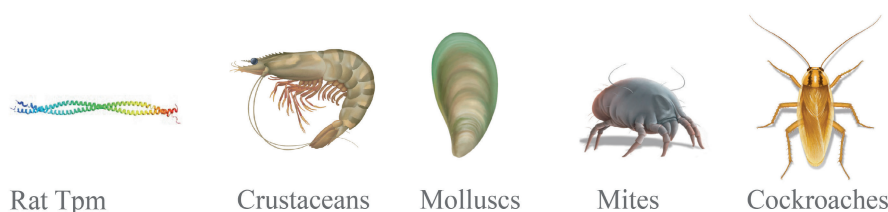


FIGURE 20 Distribution of allergenic tropomyosins. The structure shown is from the nonallergenic rat tropomyosin (PDB: 2b9c). No structure of an allergenic tropomyosin is available.

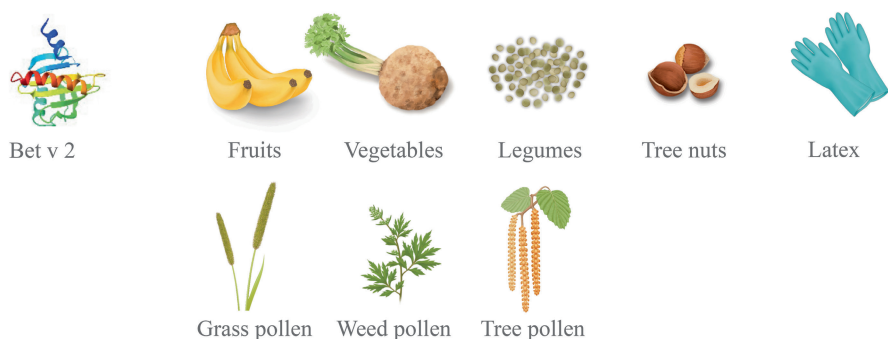


FIGURE 21 Distribution of allergenic profilins. The representative structure is from Bet v 2, the profilin from birch pollen (PDB: 1cqa).

- Allergenic legumins include the peanut allergen Ara h 3, Gly m 6 from soybean, Ber e 2 from Brazil nut, and Fag e 1 from buckwheat.

2.6. Bet v 1-like superfamily

The version 34.0 of the Pfam database attributes 104,941 proteins from 7,238 species with structures related to the major birch pollen allergen Bet v 1 to the Bet v 1-like superfamily (<https://www.ebi.ac.uk/interpro/set/pfam/CL0209/>, accessed 08/2021). These proteins are found in all domains of life and are distributed between 24 families. The members of this superfamily share the same structure, which is composed of a 7-stranded antiparallel β -sheet and 3 α -helices.³⁴⁰ There is a cavity between the β -sheet and the long C terminal α -helix, which is able to bind a variety of lipid and flavonoid molecules. So far, allergens were identified only in the Bet v 1 family, whose members are found exclusively in plants (Figure 23).

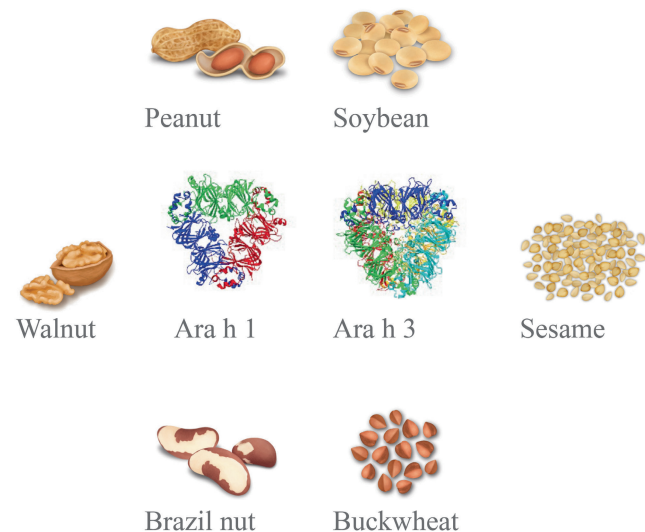
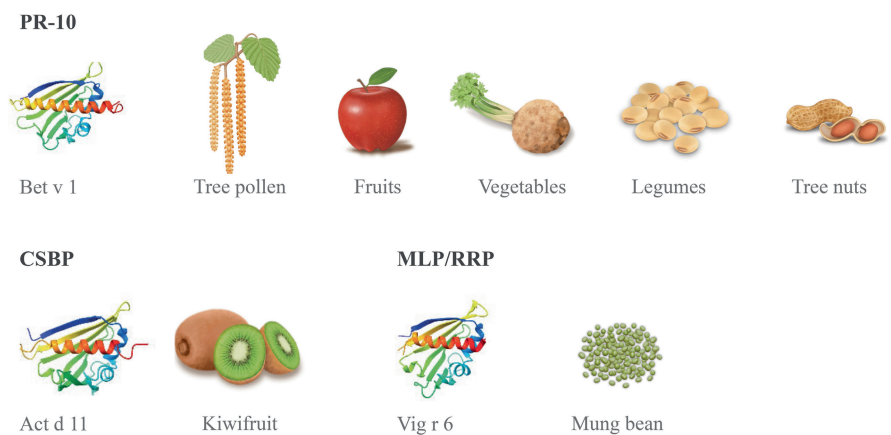


FIGURE 22 Distribution of allergenic members of the cupin superfamily. The depicted structures are Ara h 1, the 7S globulin from peanut (PDB: 3smh) and Ara h 3, the 11S globulin from peanut (PDB: 3c3v).

FIGURE 23 Distribution of allergenic members of the Bet v 1 family. The representative structures shown are Bet v 1, the PR-10 from birch pollen (PDB: 1bv1), Act d 11, the MLP/RRP from kiwifruit (PDB: 4igv) and Vig r 6, the CSBP from mung bean (PDB: 2flh).



The PR-10 proteins are the largest of the 11 subfamilies within the Bet v 1 family. The expression of these proteins is either induced by pathogen attack or abiotic stress, or it is developmentally regulated. PR-10 proteins are expressed in high concentrations in reproductive tissues such as pollen, seeds and fruits. Allergenic PR-10 proteins from pollen are found exclusively in pollen from members of the order Fagales (birch-related and beech-related trees, e.g., Cor a 1 from hazel, Aln g 1 from alder and Que a 1 from oak). Many birch pollen-allergic patients show allergic reactions to various fruits and vegetables, which are caused by IgE cross-reactivity between Bet v 1 and homologous allergens from plant foods. Most Bet v 1-related food allergens have been found in members of certain plant families: Rosaceae (e.g., Mal d 1 from apple, Pyr c 1 from pear and Pru p 1 from peach), Apiaceae (Api g 1 from celery and Dau c 1 from carrot), and Fabaceae (Gly m 4 from soybean and Ara h 8 from peanut). In addition, not all close homologues of Bet v 1 are allergens (see chapter C02).

Two other subfamilies, whose members show only low sequence similarities and IgE-cross-reactivities with PR-10 subfamily members, contain allergenic members: Act d 11, a minor allergen from kiwifruit, is the first described allergen from the RRP/MLP (ripening-related proteins/major latex proteins) subfamily.³⁴² Vig r 6 from mung bean is the first described allergen from the CSBP (cytokinin-specific binding proteins) subfamily of the Bet v 1 family.³⁴³

2.7. Calycin superfamily

The calycin superfamily comprises 16 families. Although structurally similar, calycins have rather low sequence similarities. The calycin architecture is based on an eight- or nine-stranded β -barrel, which can bind a variety of different ligands.³⁴⁴

Lipocalins are transporters for small hydrophobic molecules, such as lipids, steroid hormones, bilins, and retinoids. Allergens from this protein family include β -lactoglobulins, mammalian dander allergens, and cytoplasmic fatty acid-binding proteins.^{26,345} Beta-lactoglobulins are the major whey protein of ruminant species. Bos d 5, a β -lactoglobulin, is a major cow's milk allergen. Cross-reactions to milk proteins from other species have also been described.

Lipocalins constitute the vast majority of mammalian dander allergens. Cytoplasmic fatty acid-binding proteins are distantly related to extracellular lipocalins and β -lactoglobulins. They were identified as minor allergens in mites (group 13).

Triabins are extracellular proteins distantly related to lipocalins that were identified in insects. In the saliva of hematophagous species, they function as serine protease inhibitors that interfere with blood clotting in the host (Figure 24).³⁴⁶

- Examples for mammalian allergenic lipocalins are Equ c 1 from horse, Bos d 2 from cattle, Can f 1 and Can f 2 from dog, Fel d 4 from cat and Mus m 1 from mouse (see chapter C07).
- The prototypic allergenic member of the β -lactoglobulin subfamily is Bos d 5 from cow's milk (see chapter B10).
- Allergenic cytoplasmic fatty acid-binding proteins are Der p 13, Der f 13, and Blo t 13 from house dust mites (see chapter B04).
- Allergens from the triabin family include the minor allergens Per a 4 and Bla g 4 from American and German cockroach as well as Tria p 1 (procalin) from the California kissing bug (see chapter B05).

2.8. DPBB (double-psi beta barrel) superfamily

Members of the DPBB superfamily fold into six-stranded β -barrels defined by their distinct strand connections³⁴⁷ [40]. They are composed of two psi-loop motifs that consist of three β -strands that assume the form of the Greek letter psi (Ψ) (Figure 25). The grass pollen group 1 allergens belong to the β -expansins and contain two domains. The amino-terminal domain assumes the six-stranded double-psi β -barrel topology, and the carboxy-terminal domain consists of two stacked β -sheets with an immunoglobulin-like fold.³⁴⁸ Expansins possess cell wall loosening activities in growing cells including penetration of pollen tubes through the stigma and style.³⁴⁹ Group 2 and 3 grass pollen allergens are related to the C-terminal domain of β -expansins but lack the N-terminal DPBB domain.³⁴⁸

The kiwellin family derives its name from the kiwifruit, in which the first family members were characterized. Kiwellin contains a small cysteine-rich N-terminal domain linked to a C-terminal DPBB domain and is cleaved into its domains by the main kiwifruit protease actinidin.³⁵⁰ Kiwellins are part of the plant defense system as shown for an anti-fungal kiwellin from maize.³⁵¹

Another family of plant-defense related proteins is the barwin (barley wound-induced) family, also named pathogenesis-related proteins PR-4. Barwin-like proteins contain a DPBB domain that in some members (PR-4 class II), such as the major rubber latex allergen Hev b 6 (prohevein), is linked to an N-terminal cysteine-rich hevein-like domain and cleaved upon activation into its constituent domains.³⁵²

- Examples for group 1 grass pollen allergens are Lol p 1 from ryegrass, Phl p 1 from Timothy grass, and Poa p 1 from Kentucky bluegrass. Group 2/3 grass pollen allergens include Dac g 2 and Dac g 3 from orchard grass, Lol p 2 and Lol p 3 from ryegrass, and Phl p 2 and Phl p 3 from Timothy grass. Members of both groups are major allergens (see chapter B02).
- Allergenic members of the kiwellin family are the minor allergens Act c 5 and Act d 5 from gold and green kiwifruit, respectively.
- The most important allergenic member of the barwin family is the major natural rubber latex allergen Hev b 6 (see chapter B22).

2.9. The CAP superfamily

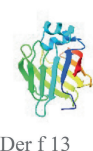
The CAP (CRISP, Antigen 5, PR-1) superfamily of proteins comprises the cysteine-rich secretory proteins (CRISPs) in the mammalian male reproductive tract and in the venom secretory ducts in many snakes, lizards, and other vertebrates, the insect venom antigen 5 family, and the plant pathogenesis-related PR-1 proteins.³⁵³ Members of this superfamily are widely spread across the bacterial, fungal, plant and animal kingdoms.³⁵⁴ The CAP domains, which are α - β - α sandwiches where two layers of α -helices flank the central three-stranded anti-parallel β -sheet, are involved in a large variety of biological processes such as reproduction, tumor suppression, and immune regulation.

Most allergens from this superfamily are major insect venom allergens including group 5 wasp allergens and group 3 ant allergens. Examples are Ves v 5 from yellow jacket, Dol m 5 from the white face hornet, and Sol i 3 from the red imported fire ant (Figure 26); (see chapter B21). Allergens from the plant PR-1 family are minor allergens. They include the Bermuda grass pollen allergen Cyn d 24, the mugwort pollen allergen Art v 2 and the muskmelon allergen Cuc m 3 (Figure 26).

Secreted lipocalins



Cytosolic fatty acid binding proteins

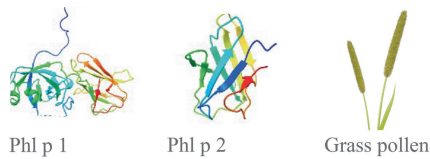


Triabins

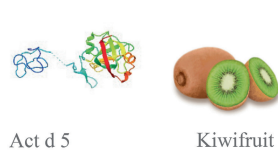


FIGURE 24 Distribution of allergens from the calycin superfamily. The representative structures shown are Equ c 1, an extracellular lipocalin from horse dander (PDB: 1ew3), Der f 13, a cytosolic fatty acid-binding protein from house dust mite (PDB: 2a0a), and Per a 4, a triabin like allergen from American cockroach (PDB: 3ebw).

Expansin and expansin-like



Kiwellin



Barwin

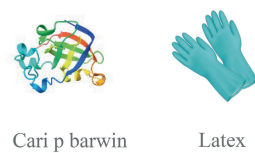


FIGURE 25 Distribution of allergens from the DPBB superfamily. The representative structures shown are Phl p 1 (PDB: 1n10) and Phl p 2 (PDB: 1who), a β -expansin and expansin like protein from Timothy grass pollen, Act d 5, a kiwelin from kiwifruit (PDB: 4x9u), and Cari p barwin, a nonallergenic barwin-like protein from papaya (PDB: 4jp7). No structures of barwin domains from allergens have been determined.

2.10. Pectate lyase-like superfamily

This large and functionally diverse superfamily is defined by the common core structure of its members, a parallel right-handed β -helix.³⁵⁵ Its members are found in eukaryotes, bacteria and viruses. Many pectate lyase-like enzymes are involved in carbohydrate metabolism. Allergenic members of this superfamily were identified mainly in pollen (Figure 27).

Pectate lyases are responsible for the eliminative cleavage of pectate and involved in pollen tube growth and fruit ripening but also expressed in plant pathogenic microorganisms. Allergenic pectate lyases are present in pollen of conifers from the Cupressaceae family (cypress and cedar) and weeds from the Asteraceae family (ragweed, sunflower and mugwort). They are highly abundant and represent dominant allergens in their pollen allergen sources (except Art v 6 from mugwort). Analogous to sequence identity, IgE cross-reactivity between botanically related members is observed, while limited between allergens from conifers and weeds.^{356,357}

Allergens were found in two other pectate-lyase-like families that contain enzymes taking part in plants in cell wall modification and breakdown, while their homologues in plant pathogenic fungi

Venom antigen 5

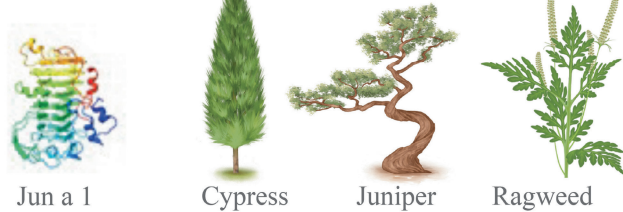


Plant PR-1

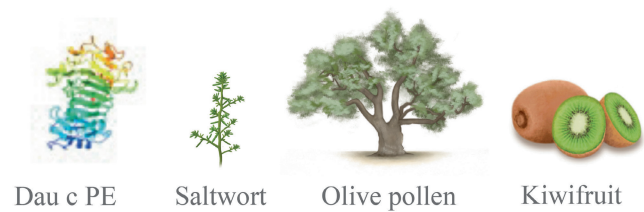


FIGURE 26 Distribution of allergens from the CAP superfamily. Representative structures shown are Ves v 5 from yellow jacket (PDB: 1qnx) and Sola l PR-1, a nonallergenic PR-1 from tomato (PDB: 1cfe). No structures of allergenic PR-1 proteins have been determined.

Pectate lyase



Pectinesterase



Polygalacturonase

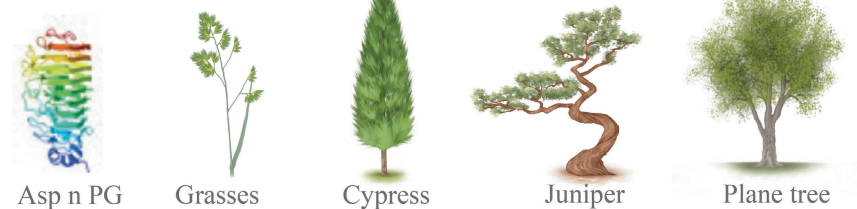


FIGURE 27 Distribution of allergens from the pectate-lyase-like superfamily. The representative structures shown are Jun a 1, a pectate lyase from mountain cedar (PDB: 1pxz), Asp n PG, a nonallergenic polygalacturonase from *Aspergillus niger* (PDB: 1nhc) and Dau c PE, a nonallergenic pectinesterase from carrot (PDB: 1gq8). No structures of allergenic polygalacturonases and pectinesterases have been determined.

and bacteria are responsible for maceration and soft-rotting of plant tissue. Polygalacturonases, also known as pectinases or glycoside hydrolases family 28, catalyse the hydrolysis of pectate. Allergens from this family are glycosylated minor allergens found in pollen from various plant families such as Cupressaceae (group 2) and grasses (group 13). Pectinesterases catalyse the de-esterification of pectin into pectate and methanol. Allergenic pectinesterases were identified in pollen and plant foods.

- Examples of allergenic pectate lyases are Jun a 1 from mountain cedar, Cry j 1 from Japanese cedar and Amb a 1 from ragweed (see chapter B01 and chapter B03).
- Allergenic polygalacturonases include Jun a 2 from mountain cedar, Cry j 2 from Japanese cedar, Pla l 2 from plane tree and Phl p 13 from Timothy grass.
- Allergenic pectinesterases are Sal k 1 and Ole e 11, major allergens from saltwort and olive pollen, respectively, as well as Act d 7, a minor allergen from kiwifruit.

2.11. Transthyretin superfamily

The transthyretin superfamily (Pfam clan CL0287) is a functionally diverse superfamily whose members are found in all domains of life and defined by their common 7-stranded β -sandwich fold. The only family that contains allergens is the Ole e 1-like family. Proteins containing Ole e 1-like domains, also known as PAC (Proline-Rich, Arabinogalactan Proteins, Conserved Cysteines) domains are found in all land plants and proposed to have a role in pollen tube development and glycan-related modifications in the cell wall¹⁶⁵⁰. They comprise a structurally conserved disulfide-stabilized β -barrel and loop regions of varying length and sequences.³⁵⁸ Ole e 1 from olive pollen was the first identified allergenic member, and Ole e 1-like proteins represent major and minor allergens in pollen of ash, privet, plantain, grasses, chenopod, and Russian thistle (Figure 28). Sequence identity and IgE cross-reactivity is high between olive and ash, while for other Ole e 1-like allergens limited or no cross-reactivity is observed.³⁵⁸ Recently, TLR-independent activation of innate immune cells was reported for Lig v 1 from privet.³⁵⁹

Ole e 1-related allergens include Ole e 1 from olive, Fra e 1 from ash, Pla l 1 from plantain and Phl p 11 from Timothy grass (see chapters B01, B02, and B03).

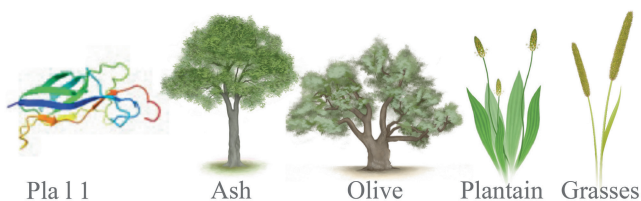


FIGURE 28 Distribution of allergens from the Ole e 1 family. The depicted structure is Pla l 1 from narrowleaf plantain pollen (PDB: 4z8w).

2.12. Papain-like cysteine superfamily

Cysteine proteases contain a cysteine residue at their active catalytic site and catalyze the hydrolysis of peptides and proteins. Despite structural similarities involving the residues that surround the catalytic site, cysteine proteases possess only low levels of overall sequence similarities.³⁶⁰ There are eight superfamilies of cysteine proteases (<https://www.ebi.ac.uk/merops>), named CA to CP.³⁶¹ Papain belongs to the C1 family of the CA superfamily. Members of the papain-like cysteine protease (PLCP) family are wide-spread and have been found in baculovirus, bacteria, yeast, plants and animals. PLCPs, such as papain, ficin and bromelain, are the most abundant family of cysteine proteases in plants and play essential roles in biotic/abiotic stress responses, growth and senescence.³⁶²

Allergenic papain-like cysteine proteases include plant food allergens such as actinidin (Act d 1), the major allergen from kiwifruit, bromelain (Ana c 2) from pineapple, ficin from fig and chymopapain (Cari p 2) from papaya, as well as group 1 mite allergens such as the major dust mite allergen Der p 1 (Figure 29) (see chapters B15 and B04).

2 – Databases

During the latest two decades, various databases covering allergens and allergen-related data have been established by academic institutions and the industry. These databases contain overlapping data, but address different user groups, use varying criteria for including allergens, and some provide additional tools such as sequence comparisons. The most widely-used, freely accessible databases are summarized below. A more extensive discussion of allergen databases was published recently.³⁶³

2.1 WHO/IUIS allergen nomenclature database (<http://www.allergen.org/>)

The allergen nomenclature database is a repository of allergens that underwent a submission and evaluation process and were accepted by the WHO/IUIS Allergen Nomenclature Sub-Committee, a panel of experts in allergen characterization, structure, and function. This is the only body officially authorized to assign allergen designations. The database contains links for each allergen to the nucleotide and protein databases of the NCBI (National Center



FIGURE 29 Distribution of allergenic members of the papain-like cysteine protease family. The depicted structure is Act d 1, actinidin from kiwifruit (PDB: 2act).

for Biotechnology Information; <https://www.ncbi.nlm.nih.gov/>), the UniProt database (<https://www.uniprot.org/>), and the Protein Databank (PDB) of macromolecular structures (<https://www.rcsb.org/>).

2.2 Allergen Online (<https://www.allergenonline.org/>) AllergenOnline provides access to a peer-reviewed allergen list and sequence searchable database intended for the identification of proteins that may present a potential risk of allergenic cross-reactivity. The website was designed to help in assessing the safety of proteins that may be introduced into foods through genetic engineering or through food processing methods.

2.3 Allergome (<https://www.allergome.org/>) The Allergome database has the most extensive collection of information on allergens and allergen sources, including data on sequences, structures, cross-reactivity, epidemiology, and an annotated list of references. It is based on the literature published since the early sixties but also contains many genomic and putative cDNA sequences listed as allergens that have been identified by bioinformatics searches from sources related to species containing allergens. Each allergen record contains an allergenicity score that helps the user in judging the relevance of the respective allergen.

2.4 COMprehensive Protein Allergen REsource (COMPARE; <https://comparedatabase.org/>)

Similar to AllergenOnline, the COMPARE database aims at providing a peer-reviewed list of allergen sequences associated with bioinformatics tools for sequence search.

AllerBase (<http://bioinfo.unipune.ac.in/AllerBase/>) The AllerBase knowledgebase is an extensively cross-linked collection of data on allergens, their sequences, structures, physico-chemical and immunological characterization, cross-reactivity and IgE epitopes, as well as IgE antibodies. Data are compiled from the literature and other databases and manually curated.

2.5 AllFam (allergen protein families, <http://www.meduniwien.ac.at/allfam/>)

The AllFam database is a resource for classifying allergens into protein families. It is curated by the host scientists. AllFam groups allergens from the WHO/IUIS database and AllergenOnline according to the protein family classification from the Pfam database (<https://www.ebi.ac.uk/interpro/>). Allfam provides a good overview on allergen families and their member proteins.

2.6 Immune Epitope Database (IEDB; <http://www.iedb.org/>)

The IEDB is a comprehensive collection of data on experimentally determined B cell and T cell epitopes in the context of infectious diseases, allergy, autoimmunity and transplantation. Data are extracted from the literature and curated by a board of reviewers following detailed published criteria. IEDB's sophisticated user interface allows for targeted searches for specific information on epitopes of allergens.

A09 – Immunotherapy and molecular allergy approaches

Lars K. Poulsen, Sarita Patil, Stefan Vieths, Ronald van Ree

Highlights

- Allergen-specific immunotherapy started in 1911 and since then, numerous studies contributed to improve efficacy and safety of this treatment.
- In parallel, characterization and quality assurance of allergen extracts have been improved and regulatory requirements have been developed for market authorization.
- So far only extract based formulations have been approved for immunotherapy and *in vivo* diagnosis.

1 – Introduction

Allergen-specific immunotherapy (AIT)—in the following referred to as immunotherapy—grew out of the successes of vaccination against infectious diseases in the late nineteenth century. The first successful attempt to ameliorate allergic symptoms was published by Noon in 1911, where grass-pollen allergic patients were vaccinated with watery extracts of grass pollen and eventually developed some form of tolerance.^{364,365} While the rationale behind the experiments—to immunize against a putative contagion—may not have been correct, the benefit for the patients made the treatment principle grow and was already in the first part of the twentieth century greatly expanded to the most common allergenic sources, such as tree and weed pollens, mold spores, cat, dog and horse dander and “house dust”—only later to be related to house dust mites.

The impact of molecular allergology on the field of immunotherapy has been enormous, but in spite of more than 20 years with recombinant allergens, still no product based on recombinant technology has yet been authorized for clinical use. There are, however, a wealth of clinical studies from which many important lessons can be learned.

In the present chapter we will focus on clinical studies, where molecular allergology has been applied to development of immunotherapy. As demonstrated in (Figure 30) a crude characterization can be made of the development lines: Starting from the crude allergen extract the search for the active components lead to an understanding that extracts contained many proteins some of which were allergens. The immunological science provided tools in the form of animal antibodies, and after the discovery of IgE in the late 1960s, the ability to measure IgE further boosted research. Combined with the development in biophysical separation and characterization techniques, this allowed detailed studies of allergens that eventually helped the manufacturers of allergen extracts to standardize the qualitative and quantitative contents of their products, and thereby ascertain an improved efficacy and safety. With the advent

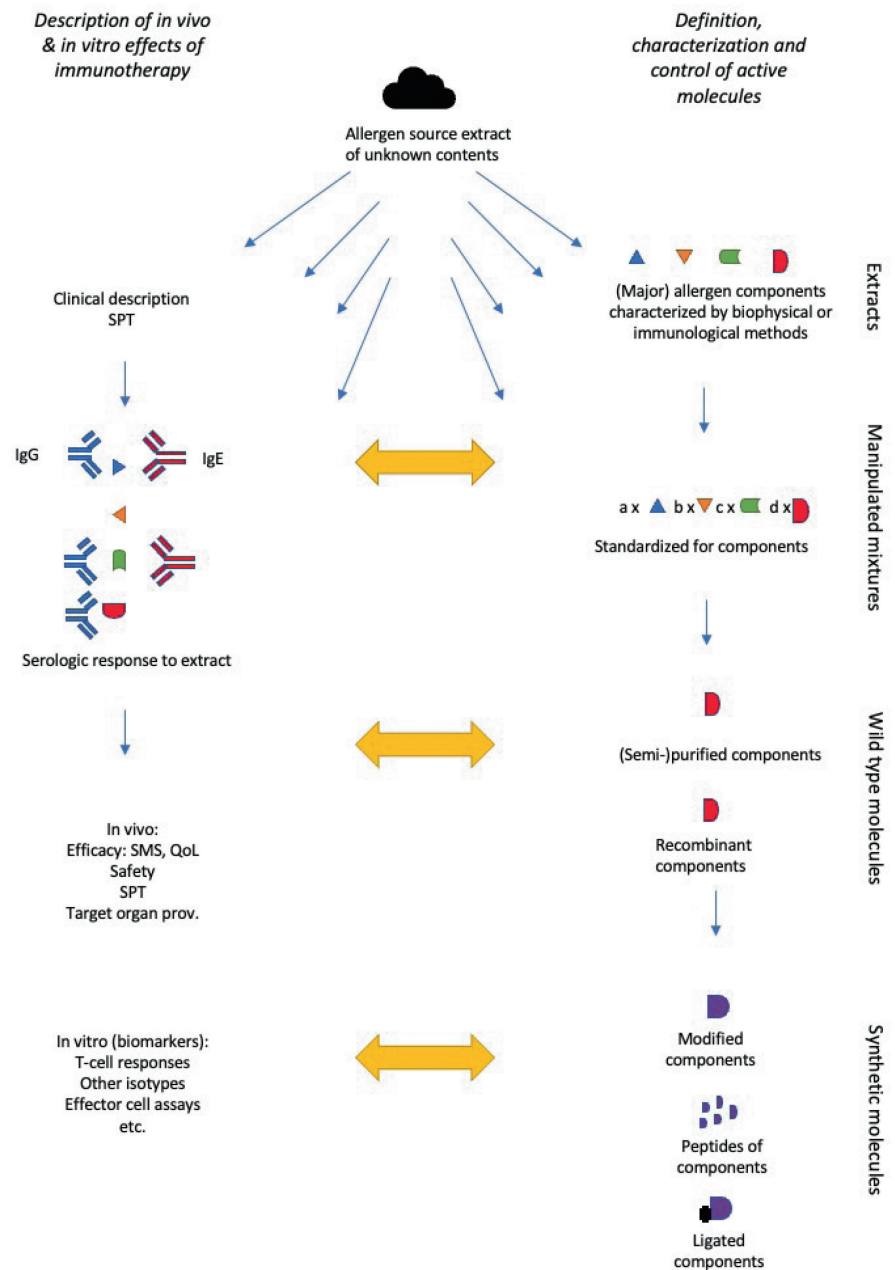
of the first recombinant molecules in the 1980s, a revolution in the possibilities of identifying, characterizing and producing allergens became available, but in spite of many attempts, the barriers for implementation in immunotherapy seem to be much more substantial than for *in vitro* diagnosis.

The interplay between the development of biotechnology to produce new molecules with an increasing understanding of the immunological mechanisms of allergy and immunotherapy sets the scene for new products of immunotherapy, but it is important also to mention the evolution in smaller increments where clinical studies have optimized dose schedules and regimens (See newest EAAI guidelines on www.eaaci.org) and combination of immunotherapy with pharmacological³⁶⁶ or immunopharmacological^{367,368} therapy. Finally, also studies of the administration routes: subcutaneous, sublingual, oral, intranasal or intralymphatic have given rise to a large body of literature, but this generally falls outside the realm of molecular allergology and will not be discussed further in the present chapter.

2 – The standardized immunotherapy extract: Ideals and reality

One of the most tangible contributions molecular allergology has so far made to the improvement of immunotherapy is to product characterization and standardization. By the time most of the major allergens of the most important allergen sources had been identified, it became clear that their (consistent) presence in immunotherapy products as important active ingredients is essential and should be monitored. Traditionally, standardization of immunotherapy products has been focused on total IgE-binding potency of extracts, using in-house reference preparations (extracts) and associated company-specific units. Competitive IgE-binding assays using pooled sera of allergic patients are at the basis of this approach. This approach stems from a time when major allergens had not yet been identified and was very much safety driven: IgE-binding potencies should not vary too much to prevent adverse events caused by too potent extracts. Overall, IgE-binding potencies do not provide insight into the content of individual major allergens but of all allergens together. In particular the development of major allergen-specific monoclonal antibodies (mAbs), provided the tools to monitor major allergen content of immunotherapy products. Slowly, companies started implementing mAb-based sandwich ELISAs to measure major allergens in their products. Gaining insight into the content of these active ingredients was a major step forward. It was, however, realized that quantification of major allergens is not as straightforward due to a number of factors. Firstly, major allergens are often present in multiple isoforms and it turned out that not all are picked up with the same sensitivity by major allergen ELISAs. Secondly, many immunotherapy products are composed of mixtures of different species, e.g., a mix of pollen from 5 or even 10 different grass pollen species or a mix of *Dermatophagoides pteronyssinus* and *farinae* house dust mites. As for isoforms, homologous

FIGURE 30 Quasi-historical developmental history of therapeutics for allergen immunotherapy (AIT). The development has taken place as an interplay between the clinical research and documentation (left column) and the biochemical description and manufacturing of the allergens (right column). Left: The monitoring of patients treated with AIT has developed from increasingly more quantitative clinical observations and skin prick tests, over serological assays to extensive immunological and inflammatory studies of biomarkers. Right: The control of the administered allergen molecules has developed from simply descriptive of the qualitative and quantitative allergen content of the natural source extract, over standardized extracts and the potential for production of wild-type allergen molecules, to synthetic designer molecules being developed based on scientific hypotheses on the vaccinology and the immune system.



major allergens from different species are usually not measured with the same sensitivity. Thirdly, each individual ELISA with its own mAbs differs with respect to performance characteristics. Finally, references used in sandwich ELISAs can be natural extracts, natural purified major allergens, or specific recombinant isoforms. It does not require too much imagination to realize that this has great impact on the outcome of these assays. The consequence of this was that 10 µg of a major allergen in product A is not necessarily equivalent to 10 µg in product B, measured with different assays. The EU-funded project, CREATE, aimed at providing an answer to these challenges.³⁶⁹ For four allergen sources (birch, grass and olive pollen and house dust mite) the project set out to characterize and compare natural and recombinant versions of eight major allergens (Bet v 1, Phl p 1 and 5, Ole e 1, Der p and f 1 and Der p and f 2) as candidates to become certified reference materials.

The second objective was to compare different available sandwich ELISAs for each of the allergens, using both natural and recombinant references, to ultimately allow selection of assays that were best equipped to measure different natural isoforms in extracts from different companies. The project was followed up by the BSP 090 program under the guidance of EDQM (European Directorate for the Quality of Medicines and HealthCare),³⁷⁰ to establish the two first changed to first two recombinant references with linked sandwich ELISAs, i.e., for Bet v 1^{371,372} and for Phl p 5.³⁷³ These references and associated ELISAs can now be used by companies to calibrate their in-house references and, if used, evaluate their in-house ELISA assays. These developments are a major first step towards application of molecular allergology into standardization and quality control of immunotherapy products, allowing more reliable comparison between competitor products.

3 – Current practices and documentation requirements

When an allergen extract is put on the market to be used for AIT or *in vivo* diagnostics such as skin prick testing, intradermal testing or target organ challenges, it is considered a biological medicinal product, and as such it needs a market authorization. In the European Union this is taken care of by the European Medicines Agency (EMA) in collaboration with the national drug agencies, and in the US by the Food Drug Administration (FDA). Several aspects of the required documentation and evaluation have been harmonized between EU and USA, but some differences remain (reviewed in³⁷⁴).

Since no recombinant allergen molecules have yet reached the market (see below), this section will focus on the regulatory issues pertaining to extract-based therapy and diagnosis. Some of the key elements in the documentation of these are:

1. Thorough description of the source material, including species documentation and quality assurance levels for pollutants such as other species (i.e., % nonrelevant pollens, or nonrelevant house dust mites).
2. Description of the production processes involved. Since even minor differences in e.g., extraction procedures may have profound effects on the yield of different individual allergens, the process is considered an inherent part of the product.
3. Establishment of an in-house reference preparation (IHRP), to which different production batches may be compared and standardized. As described in the previous section this may be done in terms of total allergenic potency of an extract or by measuring the individual allergens. Typically, a variation from 50 to 150% has been accepted for the former, and 50-200% for the latter, assuming 100% for the IRHP. It should be noticed that these variances must be adhered to for the whole shelf-life of the product.
4. Some leniency is introduced by allowing similar allergenic sources (such as birch pollen-related tree pollen, botanically related grasses, or different house dust mite species) to be grouped thus allowing for a somewhat reduced burden of documentation.
5. Clinical efficacy and side effects. For the clinical documentation the whole area has suffered from a large variability in the level of documentation. Many products have been on the market for many years and at the time they were introduced, the requirements for documentation were much smaller. Moreover, some *in vitro* diagnostic products, such as skin prick test extracts for rare allergen sources, may never reach a market value that economically justifies large clinical studies. Recently, the EU Heads of Medicines Agency (HMA) Co-ordination Group for Mutual Recognition and Decentralised Procedures Human (CMDh) has issued Recommendations on common regulatory approaches for allergen products (reviewed in¹⁷⁰³) in which it is suggested to require full clinical documentation for extracts from important allergen sources (pollen from the grasses, birch-related trees, olive- and cypress-related tree pollen, ragweed and Parietaria weed pollen, bee and wasp venom, cat allergens, and the food allergens

peanut and peach). On the other hand, well-established products on the market, and other extracts may require somewhat less clinical documentation (reviewed in³⁷⁵).

4 – Immunotherapy for food allergy

More recently, immunotherapy has been employed in the treatment of IgE-mediated food allergies. This approach models the immunotherapy approach for aeroallergens, using a build-up phase followed by an extended maintenance phase with daily allergen administration to achieve desensitization. Previous efforts using subcutaneous forms of food immunotherapy were largely abandoned due to safety concerns.^{376,1652} The best studied form, oral immunotherapy, was first developed using whole foods for administration. Other immunotherapy approaches studied for the treatment of food allergy include both, sublingual and epicutaneous administration.

Most oral immunotherapy protocols have involved the use of allergen in a flour form, which is then mixed into a food as a vehicle for ingestion. This formulation has been commonly used with high protein containing foods, including egg,^{377,378,393} peanut,^{379,380,1653,1701} and tree nuts.³⁸² On the other hand, other allergens have been administered as whole food allergens, such as in milk oral immunotherapy.^{383,384,1702}

However, the high rates of adverse reactions in whole food immunotherapy have promoted the study of using modified food allergens for oral immunotherapy, based on observations on the allergenicity of naturally modified foods. In about 70% of children with milk or egg allergy, extensively heated cow's milk and baked eggs, such as in cakes, muffins, and cookies, are tolerated. The process of heating, in the case of milk, or forming a gluten-containing food matrix, in the case of egg, modify their allergenicity by altering the protein structure and abrogating IgE binding to conformational epitopes and thereby decreasing their ability to activate allergen effector responses³⁸⁵⁻³⁹⁰. The oral introduction of modified milk and egg allergens in allergic patients have been shown to accelerate the development of tolerance^{391,392}, though not as well as oral immunotherapy.³⁹³

Modified natural allergens, with reduced allergenicity, have also been studied in oral immunotherapy. For instance, boiled peanuts have been found to have decreased IgE-binding capacity due to a loss of key allergenic components, such as Ara h 1, Ara h 2, and Ara h 6, into the cooking water.^{394,395} Immunotherapy with boiled peanuts have been shown to be safe in children with peanut allergy,³⁹⁶ and currently, a phase 2/3 clinical trial using boiled peanut in immunotherapy is ongoing (NCT02149719). Similarly, a low allergen hydrolyzed hen's egg preparation using a combination of heat and enzymatic digestion,³⁹⁷ has been used in a clinical trial for treatment of egg allergy.³⁹⁸

Engineering of recombinant food allergens, by introduction of chemical modifications or site-directed mutagenesis for abrogation of IgE-binding sites while preserving the T cell epitopes, has achieved

reduced allergenicity. This modification has been proposed as a way to increase the safety of oral immunotherapy while promoting adaptive immune responses. Several efforts to produce engineered recombinant allergens are underway with peanut, fish, apple, and peach. For instance, a phase I trial of rectally administered modified major peanut allergens, Ara h 1, Ara h 2, and Ara h 3, encapsulated in heat/phenol killed *E. coli* (EMP-123) for treatment of peanut allergy resulted in frequent allergic reactions, including anaphylaxis.³⁹⁹

Finally, sublingual immunotherapy with aqueous allergen extracts has been employed for treatment of food allergy. Previous studies have used aqueous food allergen extracts for immunotherapy to treat hazelnut,⁴⁰⁰ peach,⁴⁰¹ and peanut^{402–404,1651} allergy. Alternatively, protein powder has been used sublingually for milk.^{405,406}

5 – Immunotherapy products based on wild type recombinant allergens

The first placebo-controlled clinical trial with recombinant allergen molecules was employing a multi-allergen grass pollen mixture of recombinant allergens of *Phleum pratense*, using approximately equimolar concentrations of the recombinant allergens Phl p 1, Phl p 2, Phl p 5a, Phl p 5b, and Phl p 6, all expressed in *E. coli*.⁴⁰⁷ The mixture was subcutaneously administered in a classical dose increase with 10 weekly intervals up to a maintenance dose of around 40 mg total recombinant protein (10+5+10+10+5 mg of the five allergens). The allergens were adsorbed to aluminium hydroxide and the treatment controlled by placebo (aluminium hydroxide plus histamine) was given for about 30 months with a 50% dose reduction during grass pollen seasons. Using combined symptom-medication scores as outcome parameter, the experimental product, i.e., the mixture of recombinants showed significantly better scores compared with placebo when tested on hay fever patients allergic to grass pollen. Also immunologically, a strong induction of both IgG1 and IgG4 was demonstrated (60-fold for IgG1 and 4000-fold for IgG4). In spite of these interesting findings, subsequent studies with the experimental product failed to demonstrate superiority over placebo, and the development program was discontinued.

For birch pollen a similar product—although simpler since it only contained recombinant Bet v 1, which is the dominating allergen in birch pollen extract—was developed.⁴⁰⁸ With this product, a four-arm randomized clinical trial was developed, in which the recombinant Bet v 1, was compared with the purified natural Bet v 1 and a standardized birch pollen extract as well as placebo. The three active arms were given up to what corresponds to 15 µg Bet v 1 as maintenance dose, where the allergens/extracts were adsorbed to aluminium hydroxide. The study was run for two birch pollen seasons as a multi-center study of birch pollen hay fever patients in Northern and Central Europe. In both pollen seasons, the symptoms and medication use were significantly reduced in all three study arms receiving active allergen compared with placebo. No differences were found between full birch pollen extract, recombinant or purified natural

Bet v 1. As for the grass pollen study, strong inductions of Bet v 1-specific IgG1 and IgG4 responses were seen accompanying the treatments.⁴⁰⁸ In this case no follow-up studies were made, and an immunotherapy treatment based on the wildtype recombinant Bet v 1 has never reached the market.

The two examples presented above would suggest that it is indeed technically and clinically feasible to produce well-performing immunotherapy products based on recombinant or wild-type allergenic molecules. It is likely that overcoming economical and perhaps regulatory barriers in the future will determine whether this potential will be fulfilled to same degree in immunotherapy as we have seen *in vitro* diagnosis as exemplified by these guidelines. A summary of recombinant allergen approaches in AIT has been published by Nandy et al.⁴⁰⁹

6 – Can we learn from immunotherapy biomarkers in the monitoring of immunotherapy and for the design of new molecules?

The search for biomarkers of immunotherapy has focused on clinical need: to identify markers of clinical efficacy characterized by longer, or sustained responses after immunotherapy and to identify risk factors for increased adverse effects. On a biological level, biomarkers also promise to provide insights into clinically relevant mechanisms of disease.

Allergen-specific antibody induction after immunotherapy has been long-recognized as one of the first immunological changes to occur in immunotherapy.⁴¹⁰ Since then, increases in whole allergen-specific IgG, particularly IgG4, have been reproducibly observed in many forms of immunotherapy, including subcutaneous,⁴¹¹ oral,³⁷⁷ sublingual,⁴⁰² and epicutaneous⁴¹² forms, for treatment of several IgE-mediated diseases, including environmental, venom, and food allergies. Next, discovery of immunodominant protein allergens led to our ability to demonstrate increases in component-specific antibodies for immunotherapy to both aeroallergens and foods. However, the changes in induced antibody levels occur almost uniformly during immunotherapy and did not correlate with clinical efficacy.¹⁶⁵³ One well-studied example has been that peanut-specific IgG4 and Ara h 2-specific IgG4 increases do correlate with clinical efficacy.¹⁸⁶

Drilling down to the specific epitope-based recognition of allergens, the importance of linear epitope recognition by allergen-specific antibodies has been increasingly recognized, particularly in food allergy. Increased diversity of linear epitope recognition by IgE has correlated to clinical severity of oral food challenges in peanut allergy.^{138,413} Moreover, increased linear epitope recognition has correlated with more persistent milk allergy as well. However, linear epitope recognition has not always correlated with clinical efficacy, in either IgE or IgG epitopes after peanut oral immunotherapy.⁴¹⁴

In individuals with sensitization to allergens, immunotherapy preparations containing the particular allergen more effectively drive clinical efficacy. For instance, honey bee venom patients with Api m 10 IgE sensitization were more likely to have treatment failure,

so treatment with Api m 10 containing extracts has been recommended for those patients.¹⁰¹

Functional cellular assays have provided an *in vitro*, integrated tool for assessment of clinical reactivity. By evaluating how allergen-specific IgE binding is outcompeted by allergen-specific antibodies, these assays have been shown to be better biomarkers of clinical efficacy than the measurement of whole allergen-specific antibody serum levels. Two well-studied biomarker assays have correlated with clinical efficacy of immunotherapy. The first is a flow cytometry-based assay, IgE-FAB, which was developed as an *in vitro* assay of IgE-facilitated antigen presentation and activation of T cells during aeroallergen immunotherapy,⁴¹⁵ and which correlates with clinical efficacy after grass pollen immunotherapy.⁴¹⁶

The second assay, basophil activation testing (BAT) uses basophils, an allergen effector cell in the peripheral blood coated with surface IgE that can be cross-linked by allergen for activation, measured as CD63 upregulation by flow cytometry. Blocking antibodies can prevent IgE-cross-linking, thereby suppressing reactivity (see chapter A05). Suppression of basophil reactivity due to blocking antibodies, as well as basophil-intrinsic modulation of reactivity, occurs reproducibly during immunotherapy.^{184,377} However, basophil sensitivity, measured as a shift in the dose response curve of basophil activation to allergen stimulation, is an early biomarker of clinical efficacy in peanut oral immunotherapy.¹⁸⁶ Moreover, basophil sensitivity to whole peanut was not as useful as the change in basophil sensitivity to the immunodominant allergen Ara h 2.¹⁸⁶ Other similar assays, which use allergen-specific cell lines, such as the LAD2 cell line, have been used to create the inhibition of mast cell activation test (iMAT), which is also used to assess blocking antibodies in immunotherapy.⁴¹⁷

Other cellular biomarkers of immunotherapy have been primarily aimed at understanding the mechanisms underlying the development of allergic tolerance. Reduction in circulating allergen-specific type 2 helper (Th2) cells have been identified in both aeroallergen and food immunotherapy.^{185,418,419,420} Assays to profile allergen-specific T cells have included the use of T cell tetramers⁴²⁰ and the use of CD154 assays, where upregulation of CD154 after allergen stimulation identified allergen-specific T cells.⁴¹⁸

In summary, the application of biomarkers of immunotherapy, based on molecular identification of allergenic protein components and allergen recognition, are emerging as correlates of clinical efficacy. Advances in our understanding of the adaptive mechanisms of allergic tolerance and detailed molecular typing of allergic responses have the potential to lead to significant improvement in biomarker discovery in immunotherapy.

7 – New allergen-derived molecules for immunotherapy

A. Bits of allergens

One of the earliest initiatives to introduce molecular approaches into immunotherapy was centered on the use of cocktails of short

synthetic peptides representing dominant T-cell epitopes of major allergens. This was mainly evaluated for the major cat allergen Fel d 1 but to a lesser extent also for the major ragweed allergen Amb a 1. Already before the turn of the century, first clinical studies were performed with cat Fel d 1 peptides,^{421,422} and this was later further pursued, albeit at lower peptide concentrations. The idea behind T-cell-targeted peptide immunotherapy was to down-regulate allergen-specific Th2 cell activity, and reduce the risk of allergic side-effects due to the inability of short peptides to induce cross-linking of IgE on effector cells. At the initial higher dosages, however, significant late-phase adverse events were observed, and the field moved to lower dosages. These proved to be quite effective in Phase II clinical trials⁴²³ but finally did not reach its primary outcome in Phase III. This discrepancy was possibly explained by choices made for patient selection in Phase III rather than that the concept failed.

Two other peptide-based approaches were evaluated up to Phase II clinical trials. The first one consisted of short peptides representing minor B-cell epitopes of major grass pollen allergen, conjugated to a hepatitis antigen for T-cell help.⁴²⁴ The other approach made use of larger peptide fragments of major allergens, containing both B- and T-cell epitopes.^{425,426} In both approaches allergenicity was significantly reduced, and some degree of efficacy could be demonstrated. In Phase II, the first approach did not reach its primary endpoint and further development was in the end stopped. Also, the second approach has been abandoned due to disappointing results. Overall, the development of peptide-based immunotherapy has thus far not lived up to its initial promises.

B. Hypoallergens

The idea of creating low-allergenic molecules has a long history in allergy (historical studies reviewed in⁴²⁷) being inspired by the vaccinology field that has a century-long tradition of creation of toxoids, i.e., modified bacterial toxins, which could be used for vaccination to raise a protective immune response but without the serious pathogenic effects of the native toxins. The allergenic counterpart, sometimes referred to as allergoids or more commonly as hypoallergens, is an allergen-related molecule that has the capability to raise an immune response, preferably both in the B- (IgG) and T-cell compartment of the immune system but without the elicitation of the well-known allergic effects when administered to the allergic patient. Before the advent of the DNA-based recombinant technologies combined with a detailed structural knowledge of the allergens, more crude techniques employing heat, radiation or chemical treatments such as reduction/alkylation, formaldehyde or glutaraldehyde.

In a large EU-funded project of collaborating academical, clinical and commercial groups it was attempted to develop hypoallergenic versions of the molecules Pru p 3 from peach⁴²⁸ and Cyp c 1 from carp.⁴²⁹

Several strategies were applied for the peach LTP molecule⁴²⁸: reduction/alkylation, heat treatment, glutaraldehyde-treatment (creating an allergoid, see above and chapterA02), replacement by a natural less-allergenic homologue (Fra a 3, an LTP-molecule from

strawberry), trimerization, and mutations directed against either cysteine or surface molecules. The manufacture candidates were compared with native Pru p 3 and a wild-type recombinant molecule in a preclinical phase using IgE-binding assays and biological assays for effector cell (basophil histamine release) to screen for allergenicity *in vitro*. The immunogenicity was tested by rabbit and murine immunizations, and the molecules underwent a thorough biochemical characterization. Sera were obtained from relevant patient groups from different centers in Europe. While it was indeed possible to strongly reduce the allergenicity, this often went hand in hand with a similar reduced immunogenicity if not a downright destruction of the molecule making it unfit for pharmaceutical use.

For the parvalbumin molecule similar attempts were slightly more successful, and a single candidate (called m-(modified) Cyp c 1)⁴³⁰ was selected for toxicity studies and further clinical development. In an initial first-in-man safety study the low to absent allergenicity of the mCyp c 1 was confirmed initially by skin testing and later by actual dosing up to µg-dosages in fish-allergic patients. Moreover, promising responses of IgG were demonstrated, including demonstration that the raised IgG not only bound mCyp c 1 but also the native parvalbumin molecules from fish (see chapters B12, C11) to which the patients reacted. A subsequent study on efficacy proved less conclusive, however, and the preliminary conclusion would suggest that further dose-finding studies may be necessary.

To summarize the quest for hypoallergens there are some inherent problems in that some allergenic molecules exemplified by LTP are difficult to target with strategies for reducing allergenicity due to their structure. In many cases it is not possible to modify/reduce allergenicity without at the same time to eliminate the immunogenicity of the molecule. Even in the case of success with reduction/elimination of allergenicity while retaining the immunogenicity, the variability within the allergic population may represent a challenge: People may react highly individually to not only different allergenic molecules making the selection of candidates difficult but also differently to different epitopes on a single allergen. This may result in highly varying allergenic potencies of the same hypoallergen in different patients. It is therefore likely that at least the same precautions of careful titration will be necessary for hypoallergenic products as is the case for subcutaneous allergen immunotherapy with conventional allergen extracts.

C. Ligation to adjuvants and other new constructs

Modern vaccinology has produced a plethora of adjuvants and adjuvating principles that have also inspired the allergy field. Among the examples are chimeric molecules where B-cell epitopes of grass allergens are mixed with immunogenic viral proteins from hepatitis⁴²⁴ earlier alluded to. Initial clinical trials demonstrated strong immunogenicity but failed to reach statistical significance of primary efficacy outcomes in grass pollen-allergic hay fever patients in a randomized placebo-controlled trial. Another interesting example is intralymphatic immunotherapy with a modular allergen translocation vaccine in cat allergy^{431,432} revealing promising results in an initial clinical trial but not taken further to pivotal studies.

8 – Conclusions

There is a striking difference between the progress and success of molecular allergology in the diagnostic and the therapeutic field. This chapter has hinted at some of the challenges and barriers to develop an allergen immunotherapy based on molecular methods rather than the well-known and long used allergen extracts.

An important difference is the regulatory demands: while it is relatively easy with modern biotechnology to produce a recombinant molecule and to use it in an *in vitro* diagnostic test, the demands for preclinical testing, toxicity studies, and finally phase 1-3 in clinical randomized studies may easily last a decade and cost up to hundreds of millions of €. The strength of molecular allergy in the diagnosis, where the hyped ideal of personal medicine almost becomes true, with the possibility of obtaining a totally individualized molecular profile of IgE reactivity to individual allergens in the patient, becomes the Achilles' heel for the therapy: If allergy patients are so different, how can we ever dream of obtaining sufficient purchasing power to support the costly product development?

With the advent of the *in vitro* directive for the European Union, the increased demands for evidence-based medicine and the increasing scrutiny on each € or \$ spent in the health care sector, the diagnostic smorgasbord that is described in the remainder of these guidelines may also become reduced, but this does not help us in the therapeutic field.

With some relaxation of the present regulation, which has been seen, e.g., in the oncology field, one way forward could be a personalized approach with recombinant allergens: individual recombinant allergens produced under GMP and mixed of the shelf or used to fortify existing extracts according to the sensitization profile of the patient.

Another route of development may be an improved understanding of the immunological mechanisms of the beneficial effects of immunotherapy, which may lead to a more focused product development. The history of immunotherapy began with the famous study by Noon in 1911,³⁶⁴ and while it started a long journey towards increasingly more efficacious and safe immunotherapy products, we have to admit that rationale behind Noon's study was the incorrect notion that allergens are toxins. We have come some way in our immunological understanding, but as demonstrated in this chapter, even a clear decision on whether to go for B-cell epitopes and antibody responses or T-cell epitopes and reprogramming of the T-cell profiles (or both?) are lacking in the allergy community. In this respect it is interesting that for both of these pathways, new developments of specific allergy treatment may lie ahead: Specific IgG-antibodies to allergens can now be generated *in vitro* and administered in high dosages with seemingly high efficacy,⁴³³ Likewise from the T-cell field the concept of CAR T-cell therapy in oncology, may be transferred to allergy with infusion of *in vitro* generated and tailored T-cells based on a sample of the patients own cells. To accomplish such developments would need an even more thorough knowledge of the clinically relevant allergenic molecules and a molecular-based description of the intimate reactions with the allergen-specific receptors of the immune system.

A10 – Cross-reactive carbohydrate determinants

Ronald van Ree, Friedrich Altmann, Uta Jappe, Ekaterina Potapova, Paolo M Matricardi

Highlights

- Cross-reactive carbohydrate determinants (CCDs).
- IgE antibodies to CCDs result in a broad cross-reactivity with poor clinical relevance.
- Some diagnostic tests add a CCD-like inhibitor to rule out detection of CCD-specific IgE.

1 – Introduction

The following lines explain how the current view of the structures relevant for antibody binding by plant/insect CCDs evolved, how it became common ground that IgE binding to these CCDs does not entail allergic symptoms and have no or little clinical relevance. At the very beginning of this story, there was considerable excitement about the discovery of a highly widespread immunogenic determinant. As for IgE, the wide cross-reactivity of carbohydrate determinants was already described in 1981.¹⁶ It was a decade later that the plant typical glycoprotein structural features xylose and core α 1,3-fucose were recognized as relevant epitopes and that sera reacting with these traits also bound to certain tissues in insects, notably neurons of drosophila larvae.⁴³⁴ Soon after, the structures of the N-glycans of the major allergen of honeybee venom were exposed and found to contain the same core α 1,3-fucose as plant glycoproteins (Figure 31 and 32). Inhibition experiments then showed that this fucose residue was indeed essential for IgE binding and that the GlcNAc residue to which it is bound has to be in an intact ring conformation, in other words it has to be bound to asparagine.⁴³⁵ This complicates experimental work as it precludes the use of reduced or derivatized glycans, which are the subjects of efficient separation and handling procedures. Thus, some fine details about the role for IgE binding

of other structural details such as α 1,6-fucose or terminal GlcNAc residues are still unanswered. However, a biosynthetic approach revealed that—unlike deliberately immunized rabbits—humans do not usually produce IgE against xylose.⁴³⁶ In how far this finding reflects the route of sensitization—insect stings necessarily would only elicit anti-fucose antibodies—is a matter of speculation. The argument could be that subcutaneous contact with an allergen is more likely to induce sensitization than oral contact. Sensitization to galactose- α 1,3-galactose (α Gal) by tick bites rather than by milk or meat consumption is a highly plausible example for this mechanism.^{437,438} Meanwhile, the excitement about a newly discovered super epitope had vanished as evidence accumulated that anti-CCD IgE was of little or no clinical relevance.^{51,439} Then, however, histamine-release assays demonstrated functionality of anti-CCD IgE.^{440–442} This discrepancy probably results from the unphysiological conditions of histamine-release tests in which other components such as competing IgG are removed from the stage. Fact is that two decades of vigilance towards finding cases of substantial adverse reaction to the glycan moieties of glyco-allergens did not unearth unambiguous evidence in this direction. This is fantastic news for all allergic patients with anti-CCD IgE. They will not suffer from each plant food, plant pollen, insect remnant and so on. However, exactly because of that, this patient group experiences troubles when it comes to serum-based allergy diagnosis⁴⁴³ and even the more sophisticated cellular test systems are prone to errors caused by CCDs.^{444,445}

But let us first contemplate the reasons why anti-CCD does not or nearly not elicit clinical symptoms. Is it the very carbohydrate nature of the epitope? In analogy to the binding of most lectins to their carbohydrate ligands, the reason indeed could lie in low-binding affinities. To answer this question, patients' IgE and IgG to CCD were affinity purified, and the affinities of these pools were tested with glycoprotein ligands demonstrating the affinity of anti-CCD IgE.⁴⁴⁶ The eye-catching difference to peptide epitopes rather was the clearly higher affinity of anti-CCD IgG as compared to anti-protein IgG.

Of note, after α Gal and its significance has been identified, it was suggested that the CCD types known before α -GAL should be called classical CCD,⁴⁴⁷ a term that has been accepted in a Position Paper on CCD¹⁷.

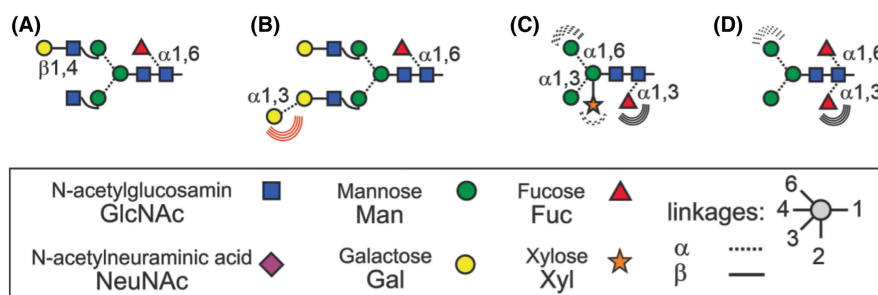
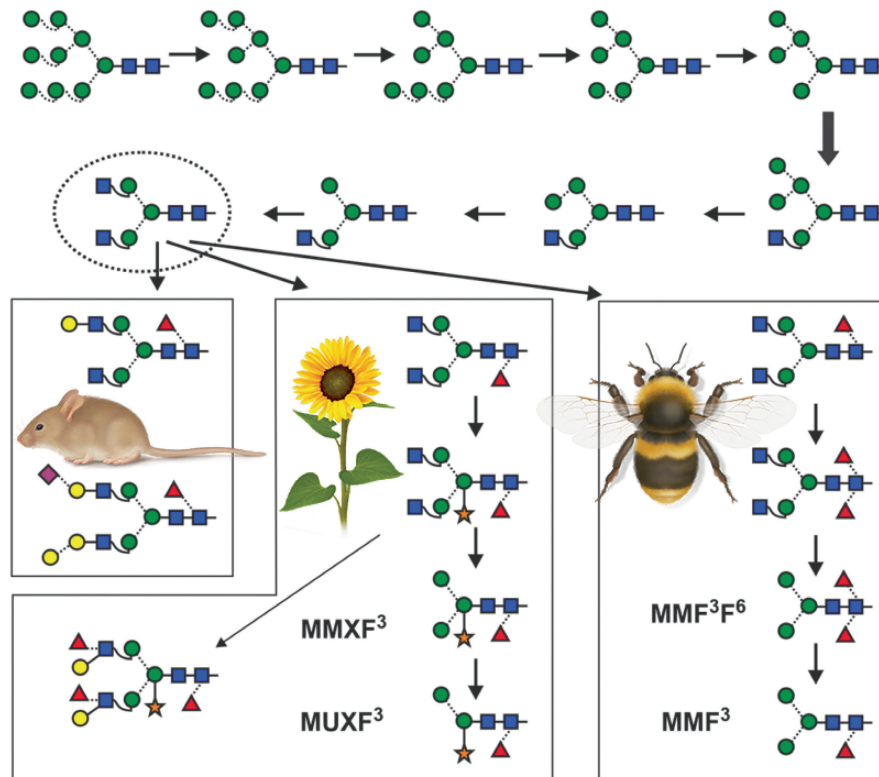


FIGURE 31 Prototypical N-glycan structures: A: example of a nonimmunogenic mammalian N-glycan; B: example of an N-glycan with an α 1,3-galactose epitope from a nonprimate vertebrate; C: the typical plant CCD structure called MMXF or short MMXF; D: CCD-structure from insect venom with both types of core-fucose. Regions deemed pivotal for antibody binding are indicated by concentric half-circles.

FIGURE 32 Biosynthesis of N-glycans in different groups of organisms. The top line shows the so called high-mannose N-glycans, whose conversion to complex-type N-glycans starts with the attachment of a GlcNAc residue (bold black arrow). From here on, the fate of glycans diverges between vertebrates, land plants and insects (and other protostomia). Structures with designations are of known relevance as CCDs.



2 - Biochemistry

The term CCD was coined for asparagine-linked oligosaccharides, usually referred to as N-glycans because the sugar is attached to the peptide backbone via the nitrogen of an amide group. Although proteins can be glycosylated in a bewildering variety of ways and each of these structures could in theory elicit IgE, the most relevant and frequently encountered structures to date are N-glycans.

Here again, two types of structures must be clearly distinguished: (a) N-glycans with α 1,3-fucose linked to the innermost N-acetylglucosamine (GlcNAc) residue (Figures 31 and 32); (b) N-glycans with terminal α 1,3-galactose (Figure 32), termed “ α Gal,” play a rather different role as will be detailed in (Chapter B14).

If not clearly specified otherwise, the term CCDs will herein refer to N-glycans with core α 1,3-fucose as they occur in all kinds and parts of land plants including mosses^{434,448,449,1704} and in a wide variety of nonvertebrate animals from nematodes to mollusks and arthropods, the latter including stinging insects.⁴⁵⁰ For the sake of clarity, these CCDs may be termed “classical CCDs”^{17,447}

The plural CCDs was chosen at a time when the structures involved were only vaguely defined.⁴⁵¹ Later, it became evident that the core α 1,3-fucose constitutes the crucial element for the human immune system whereas the xylose residue—if at all—plays a much smaller role.^{436,446} A substantiation of this notion came from a panel of peanut allergic patients. Peanuts contain predominantly N-glycans with xylose but without fucose.⁴⁴⁸ None of the sera examined, however, substantially reacted with a biosynthetic xylose-only glycoprotein (Altmann F., Eiwegger T., unpublished observations). Even though, the use of the plural form appears all the more warranted

now that the structural basis of the reaction of glycoproteins with IgE has become clearer. IgE-reactive N-glycans with core α 1,3-fucose occur in several different forms. Figure 31 just shows the most prototypical versions of plant and insect N-glycans. IgE-binding and nuclear magnetic resonance experiments with glycopeptides, free glycans and reduced glycans of various structures revealed the core α 1,3-fucose as primarily relevant, and the α 1,6-linked mannose residue as well as the intact ring structure of the innermost GlcNAc residue as likewise pivotal for antibody binding.^{434,435} However, a look at the biosynthesis pathways of the flagship CCD structures (Figure 31) shows that a variety of structures exist that fulfill these criteria (Figure 32). Notable differences between CCDs from insects and plants are the presence of xylose or of α 1,6-fucose (Figure 32). It should be added here, that xylose—though hardly an IgE epitope by itself—contributes to binding strength.⁴⁴⁶ Further heterogeneity is introduced by removal of the α 1,3-mannose from the conserved trimannosyl core-structure. Thereby the frequently found glycan MMXF is converted to MUXF (U indicating the unsubstituted 3-position), which is a structure of considerable practical importance (see chapter on competitive blocking of CCD-reactive IgE). The role of terminal substituents such as GlcNAc on either the 3- or 6-arm is totally unknown.

A survey of various allergen extracts revealed two things: all grass, weed, and tree pollens (*Poa pratensis*, *Lolium perenne*, rye, ragweed, birch, horse chestnut, pine, olive), as well as vegetable foods contained the MUXF and MMXF glycans with the exception of pea (high-mannose only) and peanut and coconut (xylosylated only structures prevailing). Differences exist in the relative occurrence of glycans with terminal mannoses such as MMXF and biosynthetic

precursors with terminal GlcNAc residues, whose role as CCDs is currently unknown. These results of structural analysis are in line with the IgE-binding observed with multi-allergen tests, where all pollen and all food allergens (see also chapters B01, B02, B03, B15, B20 and B21)—and also extracts from the insect cockroach—give more or less strong positive signals with CCD-reactive patients' sera.⁴⁴³

3 – IgE to CCD in human pathology: allergic diseases and helminths

IgE to classical CCD in pollen allergic patients

In the largest study hitherto done on IgE to CCD, an overall prevalence of 23% positivity of IgE to cross-reacting carbohydrate determinants was recorded.⁴³⁹ In this epidemiologic study, performed in over 1800 patients, the prevalence of IgE antibodies to CCD varied when different subsets of subjects were examined. Nonallergic individuals had the lowest prevalence (5%), followed by non-pollen-allergic (10%), and pollen-allergic (31%), while subsets with multiple pollen sensitization had a prevalence of 71%. Patients with an allergy severe enough to require an allergen specific immunotherapy had 46%. Only minor differences in prevalence of IgE to CCD were found when the patients were stratified by age and gender. This and many other studies suggested that IgE to CCD in allergic patients is mainly related to sensitization to pollen, although there is also quite some evidence that insect venom allergy leads to CCD sensitization.⁴⁵² In this study, the results between SPT and IgE detection to allergenic extracts had significant differences, with almost all the negative skin test outcomes turning into a positive IgE test outcome. A higher correlation was observed for plant derived allergenic extracts, and a lower one for mites and fungi. Interestingly, from the different purified glycoproteins tested *in vivo*, only horseradish peroxidase (HRP)-induced positive skin test results in 21% of the CCD-positive subjects.⁴⁵³ There is some evidence that the consumption of alcohol has considerable boosting capacity for anti-CCD-IgE, the risk of CCD sensitization being directly associated with the consumed dose of alcohol.⁴⁵³ However, it seems that “alcohol-boostered” anti-CCD-IgE only show negligible biologic activity *in vivo* (skin prick test negativity, no clinically relevant allergy symptoms).⁴⁴⁷ In summary, these observations bring us to the conclusion that IgE to CCDs are common among the allergic population. On the other hand, the fact, that patients with IgE to CCDs can provide positive results with *in vitro* IgE test with an allergen extract but remain negative to the *in vivo* SPT with the same extract, gives evidence of poor biological activity of their IgE to CCDs.

Grass pollen as inducer of IgE to classical CCD

The study discovering that pollen sensitization can generate CCD-specific IgE was published by Rob Aalberse in 1981, who also proposed the definition and the abbreviation “CCD” still nowadays globally used.¹⁶ Recently, the research question asking which pollen may be most frequently responsible for the induction of CCD-specific IgE in pollen allergic patients has been further investigated

in detail with a molecular approach.⁴⁵⁴ In this study, experiments with extended inhibition have been performed with the nonallergenic, recombinant horse heart myoglobin-glycovariants expressed and purified from insect cells as monomeric and folded proteins. IgE-reactivity and inhibition experiments established a hierarchy of reactivity of patients' IgE antibodies to plant glycoallergens, as follows: nPhl p 4, nCyn d 1, nPla a 2, nJug r 2, nCup a 1, and nCry j 1. A similar pattern of IgE recognition of plant glycoallergens has been observed earlier in allergic subjects from Africa⁴⁵⁵ and from Asia.⁴⁵⁶ Those studies demonstrated not only that the CCD recognized by the patients' IgE antibodies are heterogeneous, but also suggested that grass pollen might be the first and most frequent inducer of this category of antibodies not only in Europe but also worldwide.⁴⁵⁴ Both, group 1 and group 4 allergen molecules in grass pollen are glycosylated, so the question which of the two (or both) are contributing to the induction of IgE antibodies to CCD remains open.⁴⁵⁷

IgE to classical CCD in insect venom allergic patients

Another category of allergic patients among which IgE to CCD are frequently observed is that of patients allergic to insect venom.^{16,452} Indeed, the majority of cross-reactivities between wasp and bee allergen extracts observed in venom allergic patients can be attributed to IgE antibodies to classical CCD.⁴⁵⁸ Most Hymenoptera venom allergens are glycoproteins with one or more of such carbohydrate structures, and this makes traditional diagnosis based on extracts quite confusing in many clinical cases. This aspect is relevant as cross-reactivity often confounds the choice of allergen specific immunotherapy for such patients. An interesting study observed that IgE antibodies with specificity for the alpha-1,3-fucose CCD epitope are responsible for about 75% of double sensitizations to honeybee and yellow jacket.⁴⁵⁹ For diagnostics purposes, it is very important to discriminate among (A) genuine double sensitization to species-specific proteins of both honeybee and yellow jacket, (B) cross-reactivity due to IgE sensitization to protein epitopes expressed by homologous proteins in honeybee and yellow jacket, and (C) cross-reactivity due to IgE sensitization to carbohydrate epitopes only in both honeybee and yellow jacket. In such cases, the use of CCD-free allergen molecules in the IgE assays (component resolved diagnostics) is essential to define which of the three conditions applies to the examined patient.⁴⁵² Taken together, in most cases where the extract-based diagnostics does not allow the identification of the culprit venom due to cross-reactivity, the analysis on a molecular level applying species-specific venom allergens, devoid of CCDs, enables the detailed characterization of sensitization profiles and the identification of the venom causing clinical symptoms.⁴⁵² Recent comparative analysis on the natural (glycosylated) and recombinant bee venom allergen Api m 1 revealed that glycosylation (of the natural variant) increased allergenicity by presenting more epitopes.⁴⁶⁰ Furthermore, the glycosylated allergen induced a stronger basophil activation.⁴⁶⁰ Whether this observation—together with others on plant allergens (see below)—supports possible clinical relevance of CCD-specific IgE has still to be determined.¹⁷ Clearly, venom

(or pollen) allergic patients with CCD-specific IgE cross-react to virtually all plant foods to a varying extent, but this does not lead to clinical food allergy to these foods. Basophil activation at higher glycoprotein concentrations cannot simply be considered as proof of possible clinical relevance. In experiments with human lactoferrin expressed in rice, hence (poly-) glycosylated with plant CCD, basophil activation could indeed be demonstrated at higher protein concentrations, but when the purified protein was orally administered to pollen allergic patients with high titers of CCD-specific IgE, the glycoprotein was tolerated at gram quantities.⁵³

IgE to classical CCD in helminthiasis in rural Africa

Although IgE to CCD have been first described in allergic patients, it is becoming increasingly clear that humans frequently exposed to worms produce IgE responses against a broad variety of N-glycans.⁴⁶¹ This evidence emerged from a study showing that IgE sensitization to allergen extracts was highly prevalent (43%–73%) among the study population in Uganda but attributable not to established major allergenic components of the extracts but to CCD-bearing components instead. Experiments using glycan arrays scrutinized IgE responses to specific glycan moieties and uncovered a positive association between reactivity to classical CCD epitopes (core β -1,2-xylose; α -1,3-fucose) and sensitization to extracts, rural environment and infection to *Schistosoma mansoni*, while skin reactivity to extracts or sensitization to their major allergenic components presented no correlation. This study suggested therefore that, in this specific epidemiological setting, the worm infection, not allergens, was the inducer of the IgE response to CCD.⁴⁶¹

Do IgEs to CCD play a protective role?

Considering that helminthiasis has been a normal condition during human evolution, the question arises as to whether this category of antibodies is just an epiphenomenon in allergy, while it plays a biological function in helminthiasis. There is IgE to CCD on schistosomes and schistosome eggs. Equally there is no good evidence that the symptoms that occur with nematodes entering the skin are related to IgE antibodies specific for oligosaccharides. The function of classical CCD, whether protective against helminths or against anaphylaxis, is still unknown.⁴⁶¹ Interestingly, an inverse association was found among the patients from Uganda between the presence of IgE to a subset of CCD (those with an alpha-1,3-fucose epitope) and asthma,⁴⁶¹ which may imply a protective role of IgE to CCD.

Do IgE to CCD play an aggressive role?

Patients with schistosome infection sometimes suffer from urticaria, itching, cough, a general feeling of illness, symptoms like allergic reactions.⁴⁴⁷ It is not clear yet whether these symptoms are induced by anti-CCD-IgE.¹⁷ On the other hand, some studies have demonstrated that IgE to CCD can in a few cases induce basophil activation that correlates with clinical symptoms.⁴⁶² Similarly, a study reported five olive pollen allergic patients whose IgE antibodies to N-glycans of the major allergen of olive pollen (Ole e 1) induced basophil activation.⁴⁴⁰ In addition, a recent observation on Api m 1 showed similar results, see above.⁴⁶⁰ A clinically relevant exception is anyhow represented by the mammalian non-human disaccharide galactose-alpha1,3-galactose (α Gal)⁴³⁸ (see Chapter B14).

4 – Methodological aspects: detection of IgE to CCDs and their confounding role in IVD

Cross-reactive IgE antibodies against plant and invertebrate carbohydrate structures were first reported by Aalberse et al. back in 1981, when the term “cross-reacting carbohydrate determinant” or CCD saw the light. Already in that seminal paper, it was reported that CCD-specific IgE resulted in broad cross-reactivity to plant foods that was not accompanied by clinical allergy to these foods. In their concluding remarks, the authors state: “For some reason, possibly continuous desensitization via oral exposure-this IgE antigen system will rarely, if ever, trigger mast cells or basophils. If further investigation should substantiate this hypothesis, it would be logical to disregard antibodies to this “allergen” for diagnostic purposes. In the RAST, this can be accomplished in principle by preabsorption of sera with buckwheat antigen as CCD source or a similar preparation, but complete absorption may be difficult to achieve. Alternatively, if the relevant allergen is periodate resistant, the sera might be tested with periodate-treated allergens”.¹⁶ Now, forty years later, some commercial diagnostic tests actually add a CCD-like inhibitor to their assays to prevent detection of CCD-specific IgE (Figures 33 and 34).⁴⁴³ One assay format offers the option to add a CCD inhibitor in an immunoblot format (RIDA qLine; r-Biopharm, Darmstadt, Germany), the other adds such an inhibitor by default (ALEX² by MacroArray Diagnostics, Vienna, Austria).

Since the first description of IgE antibodies against CCD, many studies have highlighted the poor clinical relevance of such cross-reactive antibodies. The strongest support for their poor clinical relevance was provided by Mari et al.⁵³ who performed double-blind oral challenges with human lactoferrin expressed in rice, carrying multiple CCD groups. Quantities of up to 1 gram of purified CCD-carrying human lactoferrin did not induce any symptoms in pollen-allergic patients with high IgE titers against CCD. Despite this convincing *in vivo* support, reports demonstrating biological activity of CCD-specific IgE antibodies in basophil or mast cell assays keep on fueling the discussion that they may have clinical relevance, simply because they can induce mediator release. It is important to realize that concentrations needed to achieve such activity are orders of magnitude higher than of “real” major allergens. Why CCD-specific IgE is of no clinical relevance is not yet really clarified, but it has been suggested that low antibody affinity is the most likely explanation. Independent from the question why, the consensus of poor clinical relevance has created a demand for diagnostic tests that identify CCD-specific IgE as the cause of polysensitization without clinical allergy. One way is to include CCD into screening allergy panels, as a sort of alarm that polysensitization may be caused by IgE against highly cross-reactive carbohydrate groups. A step further is to try to prevent binding to allergen extracts or purified glycoprotein allergens by addition of a CCD inhibitor, as was suggested by Aalberse et al., a long time ago. A potential disadvantage of the latter approach is that the sensitivity of the diagnostic test is decreased by the competitive format requiring serum dilution. A good alternative for microarray approaches is to avoid including purified natural glycoproteins,

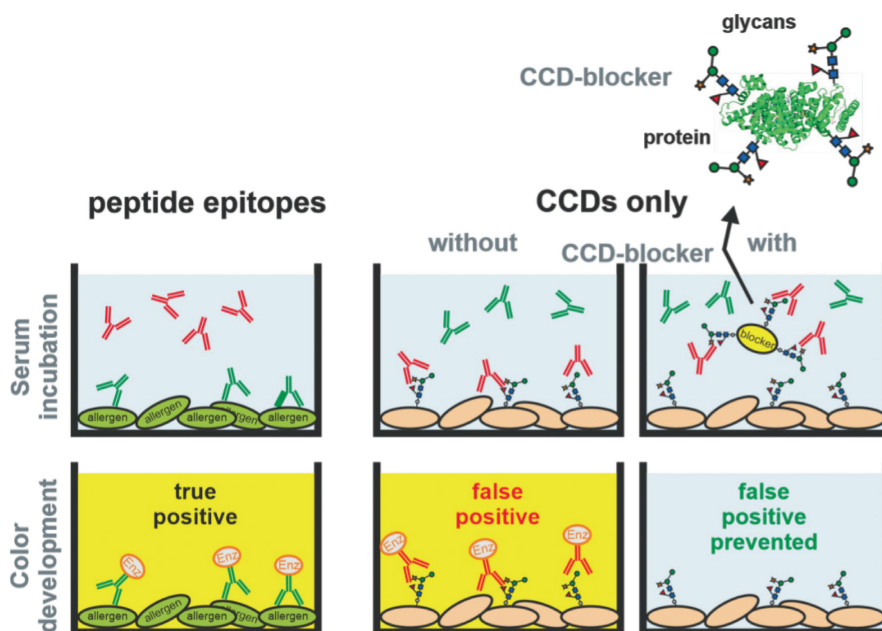


FIGURE 33 Competitive suppression of CCD-based positive results: In the course of a solid-phase IgE assay serum containing antibodies with various specificities is incubated with an immobilized allergen (upper row). Green antibodies are protein-specific, red antibodies bind to clinically irrelevant CCD structure. Antibody binding leads to color development irrespective of the biological significance. A soluble glycoprotein functions as a CCD-blocker by adsorbing most of the CCD-directed antibodies, which are removed in the washing step prior to color development.

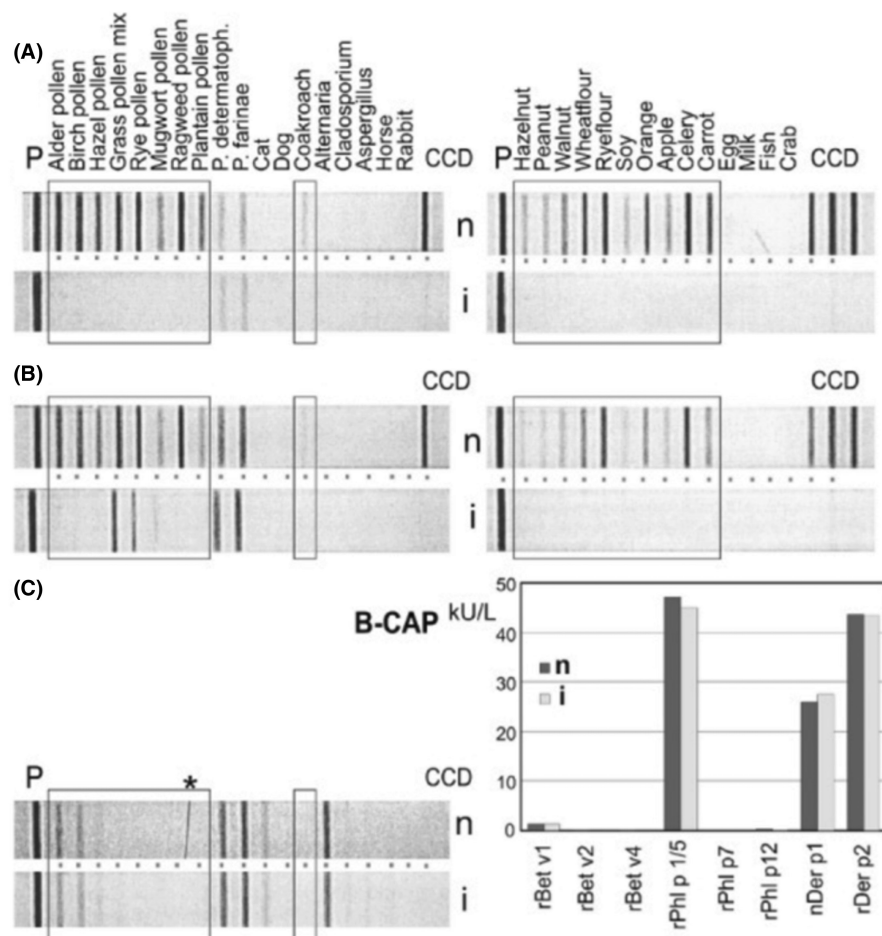


FIGURE 34 Cross-reactive carbohydrate determinants (CCD) inhibition as observed on multi-allergen test strips. Custom-made test strips with CCD markers were incubated with serum in the absence (n) or presence (i) of inhibitor (20 $\mu\text{g}/\text{ml}$). The boxes mark allergens that may exhibit CCD-based IgE binding. Sera A, B and C were obtained from patients f16, m19, and f12 (a CCD-negative patient). The * denotes a mechanical scratch in panel C. The results of CAP tests performed with serum B show that CCD inhibition does not affect exclusively protein-based reactions with allergen components.⁴⁴⁴

and if possible, replace them by nonglycosylated recombinant alternatives. The newer release of the ImmunoCAP ISAC microarray (ThermoFisher Scientific, Uppsala, Sweden) have followed that approach and have removed natural pollen and food glycoproteins that were reported to give many false-positive test results (nJug r 2, nPla

a 2). It is important to realize that specific IgE tests serve as support for a diagnosis but cannot be regarded as establishing a diagnosis on their own. Sensitive-detection of specific IgE is the aim of a good serological test, and in this setting false positive would be a background issue with nonspecific IgE binding. This is of course not what

is meant by false-positive in case of CCD-specific IgE: this is true specific IgE. In this case, false-positive is meant as clinically irrelevant. It can be argued that serological tests for specific IgE should stay away from avoiding detection of specific IgE considered to be of no clinical relevance. Should we detect specific IgE against profilins or try to avoid it because it often is of little clinical relevance? The point is: it is hard to generalize this. Perhaps therefore an approach in which specific IgE against CCD is separately detected, combined with CCD-containing extracts but as much as possible CCD-free recombinant major allergens.

5 – Clinical cases

E1 – Perennial allergic rhino-conjunctivitis with seasonal exacerbations

Clinical history—A 19-year-old patient with hay fever symptoms throughout the year but with seasonal peaks in late spring only.

First series of IgE tests—The patient serum was tested with both a customized allergy strip (Mediwiss, Moers) and the ImmunoCAP Specific IgE test. The outcomes indicated that the patient had a very broad sensitization, with positive results for alder, birch, hazel, grass mix, rye, mugwort, ragweed, and plantain pollen, as well as *D. pteronyssinus*, *D. farinae*, cockroach, hazel, peanut, walnut, wheat flour, rye flour, soy, orange, apple, celery, carrot.

Diagnostic and therapeutic considerations—given the extremely broad sensitization profile, the patient could be defined as a highly atopic polysensitized subject, whose likelihood of successful response to allergen immunotherapy would have been quite low.

Further IgE tests—The patient serum was also tested for IgE antibodies to CCD and resulted highly positive. Hence, IgE tests were repeated after incubation of the serum with a CCD inhibitor, prepared from pineapple stem bromelain and human serum albumin. This time, the IgE reactions towards all tree pollens (alder, birch, hazel) and toward ragweed, cockroach and all foods (hazel, peanut, walnut, wheat flour, rye flour, soy, orange, apple, celery, and carrot) disappeared.

Testing IgE to allergen molecules—In agreement with the above listed outcomes of the IgE tests after incubation of the serum with CCD inhibitor, no IgE to rBet v 1, rBet v 2, rBet v 4 were detected. By contrast, over 40 kU/L of IgE to a mix of rPhl p 1 and rPhl p 5, as well as over 20 kU/L of IgE to nDer p 1 and over 40 kU/L of IgE to rDer p 2 were detected.

Diagnosis and therapy—The patient had perennial rhino-conjunctivitis due to allergy to house dust mites with seasonal exacerbations due to grass pollen allergy. Accordingly, prevention of exposure to HDM and allergen immunotherapy with HDM and grass pollen extracts could be taken into consideration.

E2—Insect venom allergy: double-positivity to different hymenoptera species (Reproduced with permission from⁴⁶³)

Clinical history

A 35-year-old female patient was stung by an unidentified insect while walking on the edge of the forest. Within a few minutes,

there was a severe local swelling, and about eight hours later, a systemic reaction occurred. Pre-existing conditions: Tree pollen allergy with sensitization to birch, and a pollen-associated food allergy with oral allergy syndrome after consumption of peanuts and stone fruits.

First series of IgE tests—The patient's serum was tested with the ImmunoCAP Specific IgE test. Specific IgE antibodies were determined against whole bee and wasp venom extract: IgE to wasp venom extract: 6.25 kU/L (equivalent to CAP class 3); IgE to bee venom extract: 10.9 kU/L (CAP class 3). Total IgE: 1836 kU/l (reference range 0-100 kU/L). Serum tryptase: 6.03 µg/l (reference range 0-11.4 µg/l).

Diagnostic and therapeutic considerations—The IgE-detection assay revealed *in vitro* double positivity. The insect had not been identified, and the situation in which the patient was stung was not indicative either. There were weak positive reactions in skin tests to both venoms in different concentrations. A reliable statement concerning the culprit insect could not be made on the basis of these results.

Further IgE tests—The patient's serum was subsequently tested for IgE antibodies to CCD (MUXF3-component) and was found to be highly positive (12.80 kU/L).

Testing IgE to allergen molecules—Specific IgE antibodies against the major allergen of wasp venom, rVes v 5, were detected (2.16 kU/L) but not against the major allergen of the bee venom, rApi m 1. No sensitization was found against the second major allergen of wasp venom, rVes v 1. At that time, further bee venom allergens had not been available.

Cellular allergy diagnostic test—In addition, a basophil activation test was performed with both, bee and wasp venom. This showed a 14-fold increase in CD63 expression after stimulation with wasp venom. After incubation with bee venom, no significant stimulation of the basophils was induced.

Diagnosis and therapy—In the present case, neither the medical history nor the determination of specific IgE antibodies against bee and wasp venom extract nor the skin tests led to a clear identification of the insect venom responsible for the symptoms. Only by using the recombinant major allergens of bee and wasp venom, Api m 1, Ves v 5 and Ves v 1, could the wasp venom sensitization be diagnosed, which was confirmed by the basophil activation test. Specific immunotherapy with wasp venom was planned. By IgE determination against recombinant single allergens of bee (*Apis mellifera*) and wasp (*Vespula vulgaris*), as well as CCD, in our case, the CCD component MUXF of bromelain from pineapple, the culprit venom can be detected to a large extent. Api m 1, the major allergen of bee venom, induces sensitization in 69-80% of those allergic to bee venom. To Ves v 5, the major allergen of wasp venom, 88-90% of those allergic to wasp venom are sensitized. With a combination of Ves v 1 and Ves v 5, the sensitivity of IgE diagnostics can be increased from approx. 88% (anti-Ves v 5 IgE determination alone) to 96%. Due to the recombinant production in *E. coli*, the hymenoptera venom single allergens no longer exhibit CCD, the CCD-mediated cross-reactivity is thus⁴⁶³ eliminated.

A11 – Small molecules as immunomodulators and allergen ligands

Pierre Rougé, Christiane Hilger, Karin Hoffmann-Sommergruber, Claudia Traidl-Hoffmann

Highlights

Ligand allergen interaction can induce conformational changes and affect:

- Protein stability against gastric, thermal, and lysosomal degradation
- Accessibility of IgE antibodies
- The sensitization process

Lipids (free lipids or lipid ligands) in conjunction with allergens can act as promoters or enhancers of inflammatory (allergic) responses.

1 – Introduction and overview

The knowledge about allergens, their structures, biological functions and interactions with immune cells has tremendously increased in the last two decades. However, there is still a lack of understanding how “harmless,” nontoxic proteins can initiate an allergic sensitization in predisposed individuals. Among other factors such as impaired epithelial barriers, small molecules and allergen ligands can contribute to the onset of an allergic sensitization as it has been shown by recent findings.

In this context, small molecules include lipids, glycosylated flavonoids and derivatives thereof, steroids, fatty acids, and plant hormones. These molecules can be part of the allergen-surrounding matrix such as pollen matrix, food matrix and components from animal or plant derived dust. For some of those components direct interaction with allergens (protein – ligand) has been shown, while for others co-localization was described. For a number of small molecules their interaction with the immune system, including both, the innate and the adaptive arm, was shown. At present, a number of molecular structures from allergens have been characterized. This detailed structural analysis allows to investigate protein ligand interactions. Binding of a ligand into the cavity of an allergenic protein can induce local conformational changes. In case this affects surface exposed areas that are part of an IgE epitope, this may lead to better accessibility of IgE antibodies and increased IgE-binding activity.

Furthermore, it has been shown that ligand binding can increase protein stability against gastric, thermal, and lysosomal degradation, leading to prolonged availability of the protein to interact with the immune system. In addition, the ligand itself can interact with

immune cells, such as binding and activating surface exposed receptors of the innate immune system, e.g., Toll-like receptors (TLRs). Lipid ligands can activate certain T cell subsets via CD1 presentation and thus contribute to allergic sensitization.

This chapter summarizes recent findings about allergens and their ligands and their role in an immune response. Specifically, these new findings show that ligands can play a relevant role in mounting an allergic immune response. It collates current findings about structural data and how these interactions can influence IgE-binding activity, protein stability, and oligomerization, and thus contribute to both, the onset of an allergic sensitization process and the allergic effector phase, respectively. Furthermore, for some allergens it became evident that additional matrix components are required to induce a Th2 type immune response.

Lipocalins

The majority of mammalian allergens belong to the lipocalin protein family.³⁴⁵ Lipocalins are a highly diverse protein family with many functions, and members of the family are also found in arthropods, plants, and bacteria. Lipocalins are characterized by a common tertiary structure composed of a central β -barrel formed by eight anti-parallel β -strands. The internal binding pocket carries a broad range of small hydrophobic molecules such as retinol, steroids, lipids, pheromones, and odorants (Chapter C07). So far, only a few natural ligands have been characterized in detail. Although lipocalins are important mammalian allergens, the mechanism of their allergenicity is still elusive.²⁶ Lipocalin allergens were found to elicit weak adaptive cellular immune responses, e.g., T cell epitopes of Bos d 2 and Can f 1 were only recognized suboptimally by human T cells. It is thus likely that a major contribution to allergenicity may be based on innate immunity, receptor binding, or their role in ligand binding.⁴⁶⁴ The milk allergen Bos d 5, β -lactoglobulin, was shown to bind many ligands, mainly long-chain fatty acids, resulting in changes in structure and resistance to denaturation.⁴⁶⁵ However, Bos d 5 also binds quercetin-iron complexes and in this case the ligand load seems to provide an immune-regulatory effect and protection against allergic sensitization to birch pollen allergens in mice.^{466–468}

Whereas Bos d 5 is a food allergen, all other mammalian lipocalin allergens are respiratory allergens. They are present in saliva, dander, and urine. The crystal structures of several lipocalins have been resolved and their binding sites were analysed.⁴⁶⁹ Mammalian lipocalin allergens belong to the categories of urinary proteins, odorant-binding proteins, salivary lipocalins or the von Ebner gland (VEG) proteins and some of them were shown to bind and release small volatile compounds, suggesting a role in chemical communication. However, the role of these ligands for allergenicity needs further investigations.

Arthropod lipocalins comprise the tick histamine-binding protein Arg r 1 and the cockroach allergens Bla g 4 and Per a 4. The binding of tyramine, a biogenic amine, to the cockroach allergen Bla g 4 was characterized by X-ray crystallography.⁴⁷⁰ However, it is not yet

clear whether ligand binding has an effect on the allergenic activity of Bla g 4.

The so called mite group 13 allergens belong to the family of cytosolic fatty acid-binding proteins (cFABPs) and they are closely related to the lipocalins. cFABPs are intracellular highly conserved proteins, whereas almost all lipocalins are extracellular proteins. Lipocalins and cFABPs are members of the calycin protein superfamily and they share similar β -barrel structures (see chapter A08). As other allergens, e.g. Der p 2 and Bla g 1, Der p 13 can accommodate lipid ligands in their hydrophobic cavity, but this accommodation is not suspected to provoke important conformational changes, due to the higher rigidity of the β -sheet (Der p 2, Der p 13) and α -helix (Bla g 1) structures surrounding the hydrophobic cavity (Figure 35).⁴⁷¹⁻⁴⁷³

Group 13 mite allergens may contribute to the allergic sensitization process. Der p 13 was shown to selectively bind fatty acids and to initiate TLR2 dependent innate immune signalling.⁴⁷⁴ Furthermore, Der p 13 and Blo t 13 are sensed by an acute-phase protein, serum amyloid A1 (SAA1), that promotes pulmonary type 2 immunity.³⁸

2 – Pathogenesis-related proteins (PR-10)

Allergens from the PR-10 family are major Fagales pollen allergens such as Bet v 1, food allergens from apple (Mal d 1), celeriac (Api g 1), hazelnut (Cor a 1), peanut (Ara h 8) and many more (see also Chapter B15). There is high sequence similarity among PR-10s from related species, which is reflected by high IgE cross-reactivity with and without clinical relevance.

Pathogenesis related proteins 10 share a conserved 3D structure including a hydrophobic cavity that can take up different ligands (Figure 36). So far, a number of different ligands have been identified for PR-10 proteins including flavonoids, cytokinins, steroids,

and derivatives thereof (Table 9). This growing list of different ligands of PR-10 proteins indicates their different biological functions in the plant such as transport of small molecules, orchestrating germination and protection from environmental stress such as UV-radiation. For example, specific ligands such as the glycosylated flavonoid derivative quercetin-3-O-sophoridose were identified for Bet v 1, resveratrol for Bet v 1 and Ara h 8, genistein for Ara h 8 and Bet v 1 and fatty acids for Bet v 1.⁴⁶⁹

In the case of Bet v 1, ligand binding did not result in an increased IgE-binding activity, although binding of phosphatidylcholine to Api g 1, Cor a 1, Mal d 1, and Pru p 1 induced conformational changes as shown by changed circular dichroism spectra. This provided protection from pepsinolysis to some degree, which resulted in basophil activation even with partly digested PR-10 proteins.³³

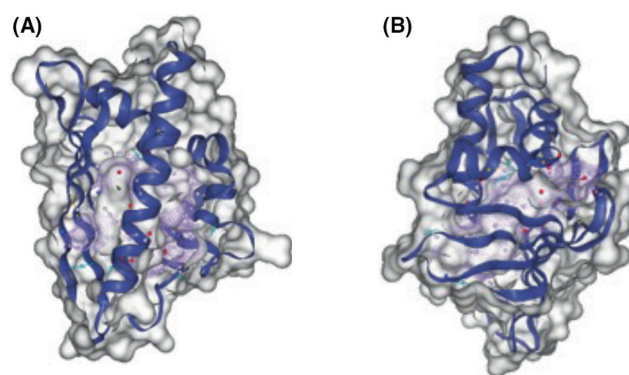


FIGURE 36 Front face (A) and lateral face (B) of Bet v 1, the PR-10 of *Betula verrucosa*, showing the extent of the hydrophobic cavity (colored violet) harboring a single or several phenolic compounds through hydrophobic interactions (cartoon drawn with the ProteinsPlus server (<https://proteins.plus/>))

TABLE 9 Structures of allergenic PR-10 Bet v 1-like proteins in complexes with natural compounds or their derivatives, available in the RCSB Protein Data Bank (PDB) (<http://www.rcsb.org>).

PR-10 protein	compound	PDB code
Bet v 1	desoxycholate	4A83
Bet v 1	kinetin	4A85
Bet v 1	naringenin	4A87
Fra a 1	catechin	4C94
Vig r 6	gibberellic acid	4PSB,
Ara h 8	epicatechin	6AX0 4MA6, 6AWV, 6AWT
Ara h 8	caffeic acid	6AWU
Ara h 8	3-hydroxy-2-naphthoic acid	6AWW
Ara h 8	quercetin	6AWS, 6B1D

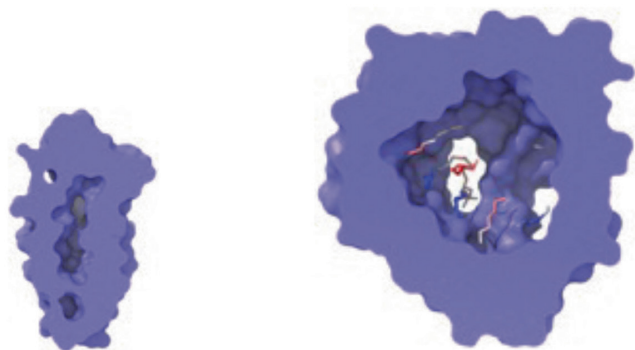


FIGURE 35 Cut sections of Der p 2 (left) and Bla g 1 (right), showing their core hydrophobic cavity. The large hydrophobic cavity of Bla g 1 can accommodate a variety of lipid molecules including fatty acids (palmitic, stearic, and oleic acids) and phospholipids (phosphatidylcholine, phosphatidylinositol, and phosphatidylserine).

However, these conformational changes seem to be more limited, as compared to those observed in nsLTP allergens. In fact, small molecule ligands enter the ligand-binding pocket of PR10 Bet v 1-like allergens but still remain far from the molecular surface area that contains the major B-cell epitope identified in Bet v 1 (Figure 36).⁴⁷⁵ This B-cell epitope is well conserved in other closely related PR10 allergens from strawberry (Fra a 1 from *Fragaria ananassa*), and non-allergenic PR-10 proteins, like St. John's wort (*Hypericum perforatum*), and LIPR-10.2B from lupine yellow seed (*Lupinus luteus*), respectively (Figure 37).

Another *in vitro* study identified phytoprostanes E1, derived from alpha-linolenic acid and present in pollen, as a ligand of Bet v 1. This specific ligand interaction conferred increased stability of Bet v 1 against proteolytic degradation by inhibiting cathepsin protease activity, which is relevant for lysosomal degradation. This prolonged proteolytic processing causes low loading and reduced number of class II MHC-peptide formation in antigen presenting cells, a process that is supposed to favor a Th2 polarized immune response.⁴⁷⁶

3 – Serum albumins

Serum albumins are highly conserved large globular proteins of mammals and birds. They are abundant in blood, but they are also present in milk, saliva, dander and meat, representing clinically relevant respiratory and food allergens (Chapter C04).⁴⁷⁷ Serum albumins transport a multitude of metabolites, nutrients, drugs, and other molecules. Their structure allows to adopt multiple conformations and simultaneous binding of various ligands.⁴⁶⁹ Due to their highly conserved function, it is conceivable that animal serum albumins transport biologically active ligands that are also recognized by the human organism with an impact on the immune response. However, there is

no information to date available whether bound ligands have an effect on the allergic immune response, neither mediated by the ligands nor by potential ligand binding-induced conformational changes.

4 – Niemann-Pick protein type C2 (NPC2) family

More than 30 allergens have been identified in both American and European house dust mites (HDMs) species (Chapter B04). Out of those, group 2 mite allergens belong to the Niemann Pick protein type C2 (NPC2) family. NPC2 proteins are carriers of cholesterol⁴⁷⁸ in vertebrates, but they are also found in arthropods. They contain a large internal hydrophobic cavity and are able to bind lipid ligands including LPS.^{469,479} Der p 2 was shown to have functional homology to MD-2, the LPS-binding component of Toll-like receptor 4 (TLR4) complex.³¹⁷ LPS binding by Der p 2 resulted in enhanced signalling by TLR4 and is considered to result in a Th2 airway inflammation. Group 2 mite allergens were also identified from storage mites, e.g., Blo t 2, Gly d 2, and Lep d 2. These data highlight the role of TLR activation and their potential contribution to the allergic immune response.

5 – Nonspecific lipid transfer proteins (nsLTPs)

Although the interaction of nsLTPs with various hydrophobic ligands has been known for a long time, only recently the involvement of lipid ligands in the allergenicity of these proteins has been questioned and further clarified. However, due to the extreme diversity of either natural or foreign ligands susceptible to be accommodated more or less specifically by the large tunnel-like hydrophobic cavity occurring in the core structure of these proteins (Figure 38), the identification of relevant ligands is a challenging task.⁴⁸⁰

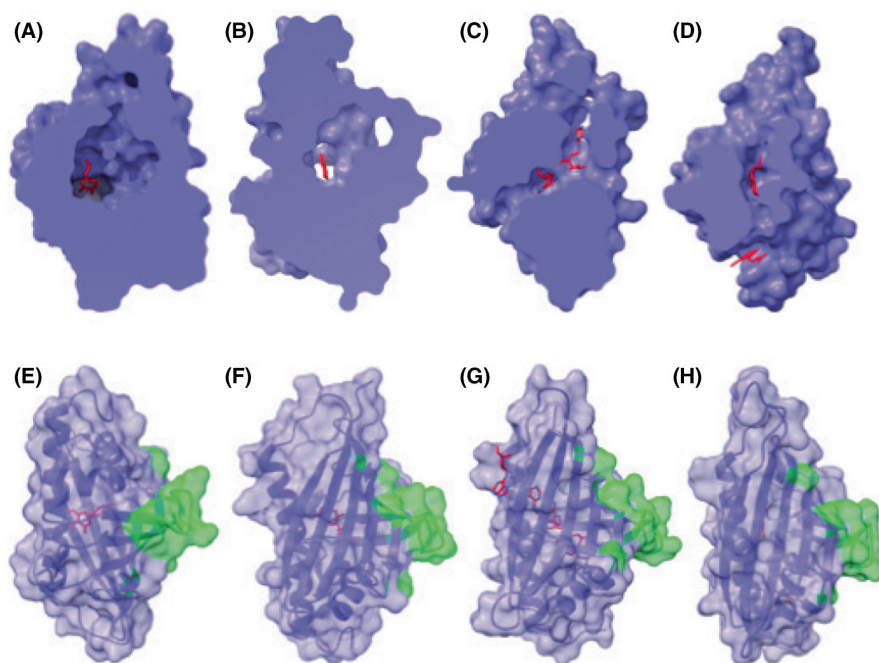
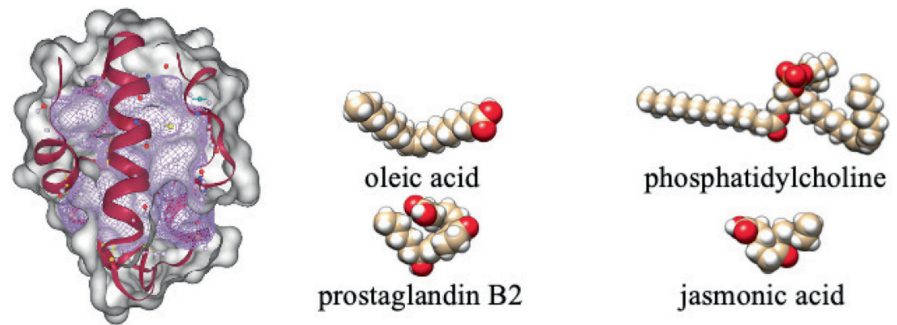


FIGURE 37 A-D. Cut sections (A-D) and complete three-dimensional structures shown with transparent surfaces (E-H) of Bet v 1 in complex with naringenin, PDB:4A87 (A, E), Fra a 1 in complex with catechin, PDB: 4C94 (B, F), LIPR-10.2B from yellow lupine (*Lupinus luteus*) with zeatin, PDB 2QIM (C, G), and PR-10 Bet v 1-like protein of St. John's wort (*Hypericum perforatum*) with melatonin, PDB 5IUF (D, H). Ligands are colored red and areas corresponding to the major B-cell epitope identified in Bet v 1, and the corresponding conserved regions of other proteins are colored green.

FIGURE 38 Cartoon showing the extent of the hydrophobic cavity (colored violet) of Pru p 3, the peach nsLTP (cartoon drawn with the Proteins Plus server (<https://proteins.plus/>)), and some apolar ligands for the nsLTP



As PR-14 proteins, nsLTP are involved in the defense of plants against abiotic and biotic stress.⁴⁸¹ They transport apolar molecules, which are used as building blocks to elaborate and reinforce the cuticular surfaces protecting the plant, e.g., from infection by phytopathogenic fungi or bacteria. They also participate in the biogenesis of cell membranes and some nsLTPs also display antimicrobial activity resulting from the permeabilization of the phytopathogen's cell membrane. Accordingly, a huge number of hydrophobic ligands can be accommodated by nsLTPs, including fatty acids, phospholipids, prostaglandins, and jasmonic acid (a plant hormone).

Pru p 3, the nsLTP from peach (*Prunus persica*), offers a nice example of a surface molecule located in the fuzz covering the fruit, which is continuously exposed to environmental factors, and is involved in the transport of lipid ligands such as oleic acid.⁴⁸²

The interaction of Pru p 3 with oleic acid was reported to enhance the IgE-binding capacity of the nsLTP.⁴⁸² As a possible explanation, a specific conformational change of the extended C-terminal loop of Pru p 3 resulting from the contact with the tail of the inserted oleic acid was determined. This has been suspected to modify the topographical distribution of amino acid residues from the discontinuous epitope #3, which coincides in part with the C-terminal loop, explaining the increased antibody-binding activity (Figure 39)¹⁶⁵⁵. By contrast, binding to oleic acid did not induce any conformational change in epitopes #1 and #2, which occur in more rigid alpha helical segments of Pru p 3.⁴⁸³

The replacement of oleic acid by stearic acid, a saturated C18 fatty acid exhibiting a trans-conformation different from the cis-conformation of oleic acid, failed to induce enhancement of IgE binding, thus indicating that a specific spatial localization of the fatty acid within the hydrophobic cavity is a prerequisite for the Pru p 3-ligand complex to induce a conformational change. A similar conformational change has been invoked to account for the enhanced IgE binding of Jug r 3, the nsLTP from walnut (*Juglans regia*), observed upon binding of oleic acid to the hydrophobic cavity.¹⁶⁵⁶

In addition to these direct effects on both, the stability and allergenicity of nsLTPs, the indirect effects of lipid ligands on the mechanism and regulation of the allergic response have been deeply investigated, using nsLTP, e.g., Pru p 3, and their natural ligands, e.g., the alkaloid camptothecin associated to phytosphingosine, as models.^{483–485} As a result, phytosphingosine was identified as a foreign ligand susceptible to contribute to the activation and regulation of

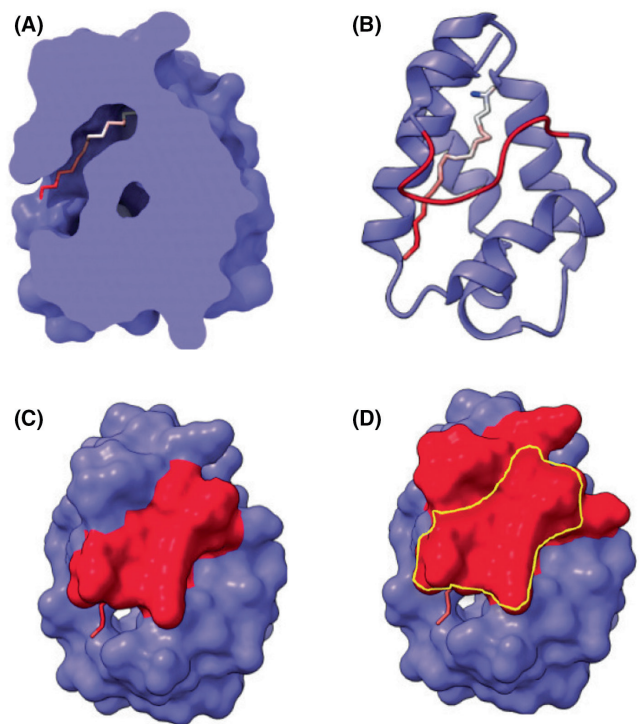


FIGURE 39 A. Cut section of Pru p 3 in complex with oleic acid (OLA) inserted in the hydrophobic cavity. B. Cartoon showing how oleic acid inserts into the hydrophobic cavity of Pru p 3 in the vicinity of the long C-terminal loop (colored red) of the nsLTP. C. Surface occupied by the C-terminal loop (colored red) of Pru p 3 in contact with OLA. D. Surface occupied by the continuous IgE-binding epitope 3 (colored red) of Pru p 3. The yellow line delineates the region of epitope 3 impacted by binding of oleic acid to the hydrophobic cavity of Pru p 3.

the allergic response via signaling pathways common to innate immunity and allergic responses (see below).

6 – Other allergens families

For Der p 5, a member of the group 5 mite allergen family, lipid binding has been shown to activate TLR2 signalling in airway epithelial cells.

7 – Immunomodulation by lipids independently of allergens

The recognition by dendritic cells (APC) of the nsLTP-lipid (Pru p 3-ligand) complex, is attributed to CD1d molecules, which are receptors structurally similar to MHC-I that process and present lipids and glycolipids to CD1-restricted unconventional T-cells, a particular subset of T-lymphocytes that specifically recognize lipids and phospholipids⁴⁸⁵⁻⁴⁸⁷ (Figure 40). CD1d on dendritic cells further present the lipid ligand to CD1-restricted invariant NKT cells (iNKT cells). The activation of iNKT cells triggers the release of various cytokines, including IL-4 that promotes the transformation of Tfh0 cells into Tfh2 cells upon the specific recognition of T cell epitopes of the allergens by MHC-II molecules. The Tfh2 cells will trigger the activation of B lymphocytes and their transformation into IgE-producing plasma cells.

Thus, lipid ligands associated to nsLTPs offer a nice example of foreign molecules capable of modulating the allergic response using activation pathways involved in the innate immune response to pathogenic microorganisms and the associated receptors, e.g., the CD1d receptors of dendritic cells.

In addition to phytosphingosine, other lipids and lipid derivatives, either free or in complex with carrier allergens, are capable of activating CD1-restricted T cells. In this respect, also lipids extracted from cypress pollen, olive pollen and Brazil nut seed were capable to activate iNKT cells.⁴⁸⁸

Other receptors specific to the innate immune response such as TLR also recognize the lipid fractions from olive or ryegrass pollens,

dust mites, and cat and dog danders.⁴⁷⁹ Additionally, many pollen grains are able to release a number of lipid mediators, the so-called PALMS (pollen-associated lipid mediators), when exposed to water. These PALMS which exhibit pronounced similarities to eicosanoids (leukotrienes, prostaglandins),⁴⁸⁹ enhance the inflammatory response and induce a Tfh2 response.^{469,490} Finally, nsLTPs appear as lipid carrier allergens that act as adjuvants, and thus trigger and activate pathways occurring in the innate immune response, to reinforce both their allergenic and inflammatory potential.⁴⁷⁹

8 – Conclusions

In summary, there is growing interest in the role of small molecules that are present in various tissues either present as ligand of allergenic proteins or as components of the surrounding matrix with a potential effect on the immune response. There is good evidence that ligands bound to a range of allergens provide increased protein stability against degradation, which in turn can have an impact on allergic sensitization. Likewise, IgE-binding activity can increase upon ligand binding as shown for nsLTPs. For some small molecules present in certain plant and animal derived tissues, also their function as immunoactive substances has been confirmed. Nevertheless, the different hypotheses on the role and relevance of additional components from allergenic sources on both, the allergic sensitization and allergic effector phase needs still more studies to provide a better understanding of this immune response.

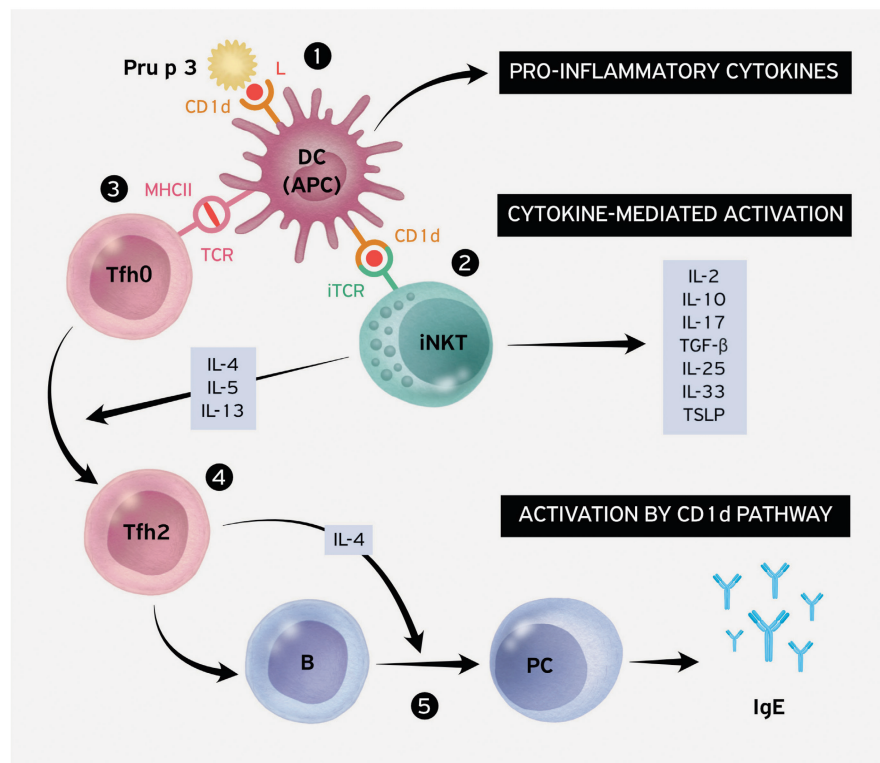


FIGURE 40 Cartoon showing how lipids can contribute to the allergic response. 1. Recognition of the nsLTP-lipid complex by CD1d on dendritic cells (DC). 2. Presentation by CD1d of lipids to iNKT cells promotes the differentiation of 3. Tfh0 (T follicular helper cells type 0) into Tfh2 (T follicular helper cells type 2) cells. 4. Tfh2 cells activate B cells (B) and 5. induce their subsequent differentiation into IgE producing plasma cells (PC).

A12 – Molecular exposure: Systematic approaches, clinical significance, and harmonization

Martin D Chapman, Adnan Custovic, Clare E N Mills, Thomas Holzhauser

Highlights

- Molecular allergen exposure assessment is a critical process for the investigation of environmental and food allergens and their relationship to allergic diseases.
- State-of-the-art multiplex technologies, including immunoassays and MS, will facilitate high throughput exposure assessment based on specific allergens that will enable thresholds for risk assessment to be established.
- Molecular exposure assessments, coupled with analyses of other environmental factors and genetic predisposition, will facilitate comprehensive epidemiologic and population studies of the role of the exposome in causing allergic respiratory diseases.
- Harmonization of molecular exposure assessments is urgently needed. This will require mutual collaboration between technology providers, academic and clinical investigators, industry and regulatory authorities to design and execute multi-center studies for validation of sampling plans and analytical detection methods.

Disclaimer: “The views expressed in this review are the personal views of the author Thomas Holzhauser and may not be understood or quoted as being made on behalf of or reflecting the position of the respective national competent authority, the European Medicines Agency, or one of its committees or working parties.”

1 – Introduction

The use of allergen molecules as markers of environmental exposure was the first practical application of allergens and preceded their use in molecular diagnostics. Instead of counting mites, pets, cockroaches or rodents, specific immunoassays were developed, which measured major allergens (Der p 1, Der f 1, Fel d 1, Can f 1, Bla g 1, Bla g 2, Rat n 1, Mus m 1) in dust, air, and other environmental samples.⁴⁹¹

Measurements of these allergens provided an objective and quantitative index of exposure that could be directly compared between study populations and cohorts. That the allergens being measured were a primary cause of IgE sensitization underscored this molecular approach to environmental exposure assessment.

Allergen measurements have been widely used for exposure assessments in clinical and epidemiological studies to investigate the relationships between allergen exposure and sensitization; disease associations and risk factors; geographic and climatic differences

in exposure; occupational exposures; and factors influencing the aerodynamic properties of allergens.⁴⁹² Other applications include efficacy testing of products, devices, and mitigation processes; assessments of the potency of therapeutic products; and monitoring of allergen exposure in Environmental Exposure Chambers (EEC) as part of clinical trials of allergy therapeutics.⁴⁹³ Recently, the molecular exposure approach has been extended to include food allergens and pollen allergens. Processing of foods presents challenges for allergen measurements. However, significant progress is being made by monitoring specific allergens in foods and quantifying them in food products, as well as in environmental samples, such as dust. This has become especially important in identifying and quantifying the presence of unintended allergens in foods, which are not added as ingredients but may find their way into foods during food production/preparation and cause allergic reactions.⁴⁹⁴ While pollen grain counts remain the standard for assessing pollen exposure, measuring allergen levels in pollen grains has demonstrated differences in geographic variability and allergen potency that are becoming more important with the advent of climate change.⁴⁹⁵ Finally, multiplexing of allergen assays has greatly expanded the scope of allergen measurements and for both indoor allergens and foods. The most important allergens can be measured in a single test. The application of mass spectrometry is also providing more information and new ways of quantifying allergens whether in environmental samples or foods and can provide complementary data to immunoassay methods.^{496,497}

2 – Allergen Exposure: Objectives, Methods, and Applications

The objectives of molecular exposure assessment can be summarized as follows:

- To provide consistent and reliable indices of environmental allergen exposure that are directly comparable.
- To use high throughput sampling methods and assay technologies that have adequate sensitivity, specificity and quantification, with validated performance parameters that can be verified through multi-center ring trials.
- To reliably assess the risks and outcomes of allergen exposure in different localities, populations, and circumstances in relation to health effects and as a guide to public policy and improving quality of life.

Sampling Methods

The standard method for sampling indoor allergens has been to collect reservoir dust samples from bedding, bedrooms and other living spaces using a modified hand-held vacuum cleaner with a dust collection device. Typically, an area of ~0.25 m² is sampled for 2 minutes, and results are expressed as ng or µg allergen per gram of dust.⁴⁹¹ This approach accommodates dust mite and cockroach allergens, including Der p 1, Der p 2, Bla g 1, and Bla g 2, which do not readily become

airborne. Airborne mite (*D. farinae*) antigens were measured using a polyclonal ELISA and GSP air samplers.⁴⁹¹ While this is a promising approach, the specific molecular allergen components being measured in the ELISA have yet to be established.⁴⁹⁸ Personal air samplers, such as IOM and GSP samplers, and glass fibre filter cassettes, can be used for allergens of small particle size (2-10 μm diameter) that remain airborne for several hours (e.g., cat, dog and rodent allergens). Measurements of airborne Mus m 1 and Rat n 1 have been used to investigate laboratory animal allergy (LAA).⁴⁹⁹ The pharmaceutical industry has developed programs to monitor rodent allergen exposures as part of its facilities management programs, with the goal of reducing exposures to $<5\text{ ng}/\text{m}^3$ to mitigate LAA.⁵⁰⁰ Recently, electrostatic dust collectors have been used to measure settled airborne dust. These collectors are placed at a height of 1.6 m in a room and passively absorb allergens onto 2-4 polyester cloths over a 14-day period.⁵⁰¹ They can then be mailed to a lab for allergen testing. Silent electrokinetic air samplers that plug in to an electrical socket have been developed for high volume sampling and have been used to assess allergen exposure and the microbiomes in US homes.⁵⁰² Sampling of raw ingredients, in-production foods and finished food products presents different issues related to the chance of identifying low level contamination of allergenic ingredients either as a consequence of agricultural comingling or carry-over between manufacturing runs of foods.⁵⁰³ For example, change over between milk and dark chocolate, which can result in levels of milk allergens that pose a risk to allergic consumers.⁵⁰⁴

Immunoassay Methods and Applications

In early studies of environmental exposure, allergen molecules were measured by two-site enzyme-linked immunosorbent assay

(ELISA) using specific monoclonal antibodies (mAb) for allergen capture and biotinylated mAb (or polyclonal antibodies) for detection. Assays were quantified using purified allergen standards of known protein content that were sub-standardized against international reference preparations, where available. Extracts of household dust samples were compared by ELISA in many epidemiologic studies, including emergency room asthma studies, the US National Institutes of Health Inner-City Asthma Consortium (ICAC) studies, the Manchester Allergy and Asthma Study (MAAS) and the German Multicentre Allergy Study (MAS) prospective birth cohorts.⁵⁰⁵ These studies provided comparative data on multiple allergen exposures across different parts of the world and their relationships to IgE sensitization and allergic disease.⁵⁰⁵ Although ELISA is a high throughput assay, measurement of each allergen in a separate assay was a limitation, especially for large studies involving multiple allergens. Nonetheless, the core components of ELISA, the mAb used for allergen capture and detection could readily be used in other assay systems. The X-ray crystal structure of allergen-mAb complexes has been determined for Der p 1, Der f 1, Der p 2, and Bla g 2 and the amino acid residues that form the allergen epitope are now known.^{506,507} This level of molecular analysis is not possible using polyclonal antibodies. The structural data confirm that the mAb epitopes are nonoverlapping and bind to distinct conformational sites on allergen molecules (Figure 41).

The mAb used in ELISA were incorporated into a Multiplex ARray for Indoor Allergens (MARIA) using Luminex xMAP technology. Capture mAb were covalently coupled to polystyrene beads with internal fluorescent dyes. Bound allergen is detected using biotinylated detector mAb and streptavidin-phycoerythrin. The beads are analysed in a Luminex instrument in which a red laser distinguishes the bead set coupled to the capture mAb and a green laser

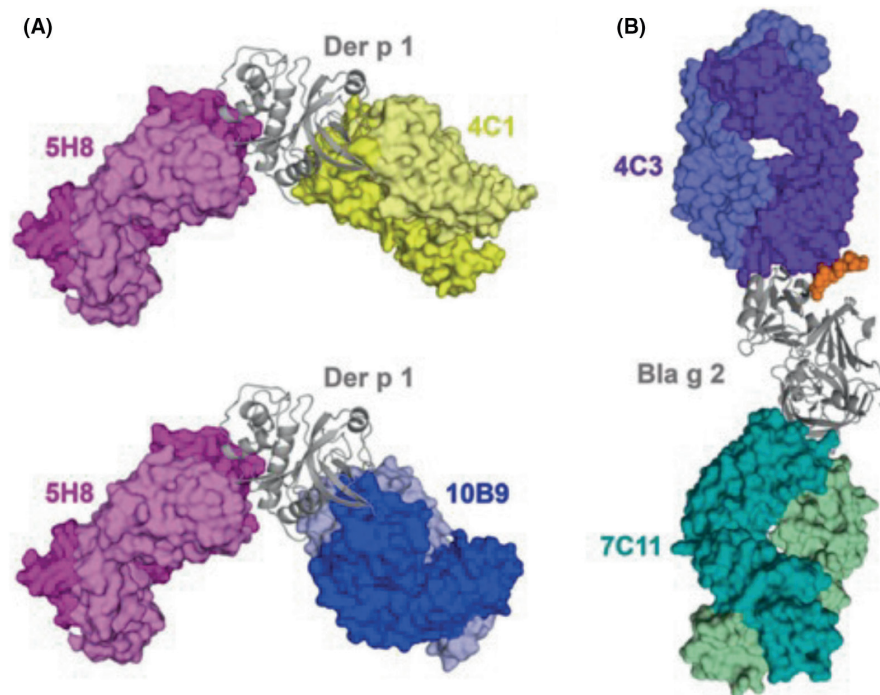


FIGURE 41 X-ray crystal structures of allergen-mAb complexes: A, mAb 5H8, 10B9 and 4C1 in complex with Der p 1; B, mAb 7C11 and 4C3 binding to nonoverlapping sites on Bla g 2. Reproduced from Pomés et al, *Frontiers in Immunology*, with permission⁵⁰⁶

detects the mean fluorescent intensity and measures the amount of allergen in the sample (Figure 42, Table 10).

Luminex xMAP technology is widely used in allergy/ immunology (e.g., for measuring cytokines). The MARIA assay was validated in an international ring trial and can measure up to 14 aeroallergens simultaneously, under the same assay conditions.⁵⁰⁸ The sensitivity of MARIA is 10-40-fold greater than ELISA, which is especially useful for measuring airborne allergens, e.g., in LAA. The development of MARIA enabled larger population studies and greatly increased the scope of exposome analyses, as illustrated by the U.S. National Health and Nutrition Examination Survey (NHANES, Case Study I).⁵⁰⁹

Molecule-based approaches are increasingly being applied to food allergy. Monoclonal antibody-based ELISA for specific food allergens, including peanut (Ara h 1, Ara h 2, Ara h 3, Ara h 6); soy (Gly m 4, Gly m 8); egg (Gal d 2); milk (Bos d 5, Bos d 11) and carrot (Dau c 1, Dau c 4) have been developed and applied to measure

allergens in foods, processed foods, immunotherapy products and early introduction foods.⁵¹⁰⁻⁵¹⁷ A modified multiplex array, MARIA for Foods, measures up to 17 major food allergens. MARIA for Foods measures all the food allergens that are regulated in the US (peanut, milk, egg, soy, tree nuts, sesame, fish, shellfish, wheat, celery, mustard) and which are also regulated in the European Union as part of a larger list of 14 allergenic foods.^{518,519} The MARIA for Foods has recently been used to measure the specific allergen content of commercial early introduction foods that are marketed to consumers as aids for the prevention of food allergy in infants.^{520,521} MARIA technology has also been applied to measure environmental exposure to indoor allergens and food allergens in schools in the North-eastern US, as part of the Schools Inner-City Asthma Study (SICAS, Case Study II).^{522,523}

Alternative methods of molecular exposure assessment have been developed including quantitative PCR (qPCR), DNA-based

FIGURE 42 Schematic representation of MARIA for Der p 1, Der f 1, and Bla g 2

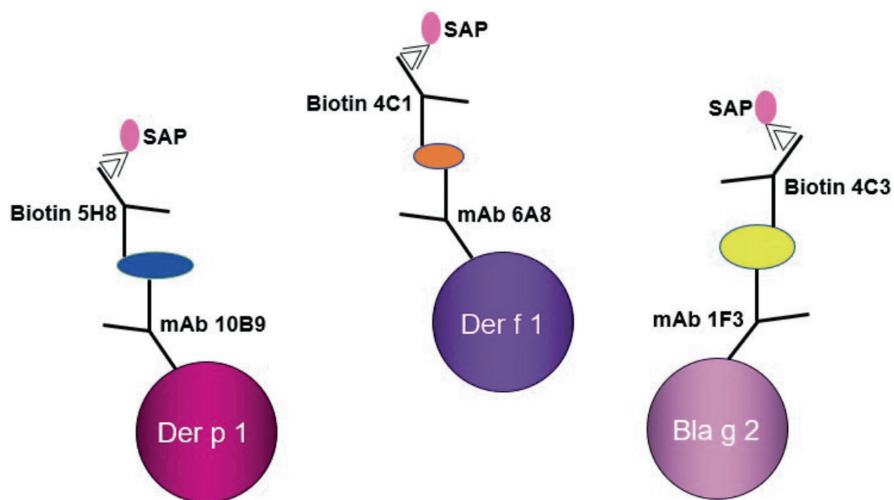


TABLE 10 Antibodies, Allergen Standards and Bead Sets Used in MARIA for inhaled allergens

Source	Target allergens	Capture Ab	Allergen standard	Magnetic bead set	Detector Ab
Dust Mite	Der p 1	10B9	nDer p 1	15	5H8
	Der f 1	6A8	nDer f 1	37	4C1
	Der p 2	1D8	nDer p 2	45	7A1
	Der p 23	7A8	rDer p 23	63	pAb
	Blo t 5	pAb	rBlo t 5	35	pAb
Animal	Fel d 1	6F9	nFel d 1	55	3E4
	Can f 1	10D4	nCan f 1	12	6E9
	Mus m 1	pAb	nMus m 1	57	pAb
	Rat n 1	RUP-6	nRat n 1	64	RUP-1
Cockroach	Bla g 2	1F3	nBla g 2	26	4C3
Pollen	Bet v 1	6H4	rBet v 1	72	5B4
	Phl p 5	1D11	rPhl p 5	67	Bo1
	Amb a 1	2B6	nAmb a 1	29	4H7
	Lol p 1	5G7	nLol p 1	13	7D8

biosensors and mass spectrometry (MS).⁴⁹² These tests show promise but need to be validated for use in environmental studies. Mass spectrometry analysis of dust samples has provided useful qualitative data confirming the presence of peanut allergens in dust.⁵²⁴ Using MS in combination with immunoassay and PCR methods provides a synergistic approach to molecular exposure assessment, which can be modified to suit specific applications and to overcome method-specific limitations.⁵²⁵

3 – Special Considerations for Food Exposures

Inadvertent exposure to food allergens can cause serious adverse reactions in food allergic patients, including anaphylaxis. For this reason, the presence of the most common allergens in food is regulated by the US FDA and regulatory authorities in Europe and other countries. The nine allergens regulated in the U.S are milk, egg, peanut, tree nuts, soybean, sesame, wheat, fish and shellfish.⁵¹⁸ In addition to these nine allergens, sesame, lupin, molluscs, celery, and mustard require mandatory labeling as food ingredients in Europe.⁵¹⁹ The first ELISA methods for food allergen detection were published in the mid-1990s, followed by the development of PCR and MS methods. All these methods present specific strengths and limitations for allergen measurements, which have recently been reviewed in detail.⁵²⁶ Immunoassays such as ELISA and lateral flow tests have been most widely used for measuring allergens in foods and in food processing facilities for sensitivity and ease of use. The limitations of these assays often include poorly defined analyte specificities and variability of assay performance, depending on food processing. While PCR methods usually have potential for high specificity for the allergenic food, the DNA-based detection of allergens, which are proteins, remains indirect. Multiplex array technologies, such as xMAP FADA (developed by the US FDA) or MARIA for Foods, are high throughput approaches that enable multiple food allergens to be measured simultaneously.^{520,527} Immunoassay epitopes may be denatured by food processing procedures such as heat treatment, polymerization or acid precipitation. Under these conditions, targeted allergen specific detection and quantification by LC-MS/MS, using peptides derived from allergen sequences, is a valuable alternative approach.^{528–530} Mass spectrometry is an exciting new tool for molecular exposure assessment of allergens in environmental samples and foods. The common denominator with new immunoassay methods is that both approaches measure specific allergen molecules and should provide greater consistency of allergen measurements when information about molecular allergen components is required. Various MS methods have been developed with allergen-specific peptides of peanut Ara h 1, Ara h 2, Ara h 3, soybean Gly m 5 and Gly m 6, hazelnut Cor a 9, wheat gliadins, cow's milk Bos d 4, Bos d 5, Bos d 9, Bos d 10, and hen's egg Gal d 2, and Gal d 4, allowing a sensitivity of approximately 1-10 mg total protein of the allergenic food per kg of food matrix, or even below, in typical matrices such as cookie, bread, cereals, ice cream and chocolate.^{526,530,531} Multi-analyte methods capable of detecting and quantifying several

allergens have been developed.⁵³² MS methods can also provide absolute quantification, which lends itself to the development of reference methods.⁵³³

4 – Clinical Significance of Allergen Exposures

Effect on the development of allergen-specific sensitization and allergic diseases

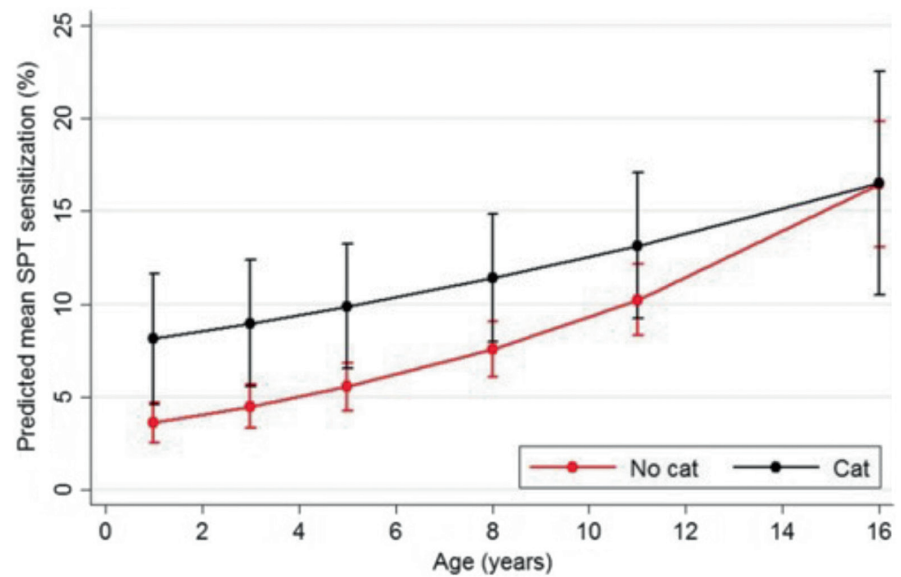
Allergen exposure impacts the risk of sensitization and allergic disease and is influenced by the route of exposure (e.g., inhaled, transcutaneous, oral), its dose, timing, and individual genetic predisposition.⁵³⁴ Allergen exposure is essential for the development of allergen-specific sensitization, but the nature and the direction of this relationship is a matter of a considerable debate. For example, the evidence on the role of house dust mite (HDM) and cat exposure is contradictory. A Swedish birth cohort reported increased risk of cat-specific sensitization at age 4 years with increasing early-life cat allergen exposure.⁵³⁵ A similar dose-response relationship for both HDM and cat exposure was observed in the German Multicenter Allergy Study.⁵³⁶ By contrast, the opposite finding of a protective effect of high cat allergen exposure on cat sensitization (with a bell-shaped dose-response relationship), was reported in several cross-sectional studies in older children and adults (reviewed in⁵³⁴). The reasons for such heterogeneity include the study design (birth cohorts vs. cross-sectional) and the choice of population (high-risk vs. population-based), making direct comparisons difficult.

The limitations of drawing conclusions about the role of early-life exposures from cross-sectional analyses underscore the importance of looking at life-course trajectories. A recent longitudinal analysis showed that sensitization to cat in the first 3 years of life was significantly higher amongst children living in a home with a cat and exposed to high level of Fel d 1, but after this age, the annual increase in sensitization was lower compared to children without a cat. By adolescence the point prevalence of cat sensitization was numerically higher among children without a cat (Figure 43).⁵³⁷ These findings may explain inconsistencies in previous literature and indicate that apparently contradictory findings may be a consequence of different longitudinal trajectories of cat sensitization between those exposed to high and low cat allergen levels.

The route of exposure and the role of genetic predisposition

General assumption is that the default route of exposure to inhalant allergens is via inhalation, and to food allergens via the oral route. Sensitization may also be a consequence of allergen presentation through an impaired skin barrier, which is important within the context of filaggrin genotype. In an unselected birth cohort (MAAS), peanut allergen in house dust increased the risk of peanut sensitization and peanut allergy in a dose-response manner in children with filaggrin loss-of-function mutations, but not in those without, providing evidence that (i) transcutaneous exposure is important in food allergy and ii) that susceptibility to allergen exposure differs between individuals with different genetic predispositions.⁵³⁸ Filaggrin loss-of-function mutations also modify the impact of exposure to HDM

FIGURE 43 Longitudinal trajectories of cat sensitization (SPT-skin prick test) among children who lived in a home with a cat in early life and those who did not. Predicted value of mean response is shown in graphical format along with 95% confidence intervals (From ⁵³⁷, with permission).



and cat allergens on the development of allergen-specific sensitization. In the MAAS cohort, Der p 1 and Fel d 1 exposure was much greater among children with filaggrin mutations compared to those without.⁵³⁹ This analysis confirmed previous observations that the association between early-life allergen exposures and sensitization changes with time. In real life, individuals are contemporaneously exposed to a range of other environmental exposures. One example is the observation that high allergen exposure combined with an environment rich in specific bacteria may protect against sensitization and atopic wheezing.⁵⁴⁰ Gene-environment interactions add to this complexity.

Increasing early life Der p 1 exposure was associated with increased risk of mite sensitization. The impact of allergen exposure was markedly reduced at high endotoxin exposure, but only among children with specific genotype in CD14.⁵⁴¹ These findings confirmed that sensitization is influenced by allergen exposure, by other environmental exposures, and by genetic predisposition. Consequently, the effects of allergen avoidance may differ between individuals with different genotypes.

Effect of allergen exposure on asthma severity and exacerbations

Most studies that investigated the impact of exposure on symptoms among sensitized patients with established disease reported increased severity with increasing exposure. Amongst allergic asthmatics, indicators of asthma severity (including increased airway hyper-reactivity and Peak Expiratory Flow Rate (PEFR) variability and diminished lung function) are associated with high exposure to sensitizing allergen, emphasizing the contribution of allergen exposure to the ongoing chronic disease process.⁵⁴² High allergen exposure in sensitized asthmatics interacts with virus infection in increasing the risk of exacerbation in children and adults.^{543,544} Evidence that high exposure to allergens can worsen asthma symptoms indicate that effective allergen avoidance should improve asthma control. However, attempts to replicate clinical benefits observed in occupational asthma, or the studies at high altitude sanatoria, by using

allergen control measures in patients' homes, have provided conflicting results (reviewed in⁵⁴⁵).

Allergen avoidance in the treatment of asthma Several systematic reviews and meta-analyses have questioned the role of HDM avoidance in sensitized asthmatics, resulting in a lack of consensus and conflicting recommendations by national and international asthma guidelines. The limitations of such analyses and why one should not disproportionately rely on meta-analyses and systematic reviews to inform clinical practice have been reviewed.^{545,546}

In adults, two large randomized double-blind, placebo-controlled trials assessing the effectiveness of mite-impermeable bed covers as a single intervention found no benefits on morning PEFR during the first 6 months, or the proportion of patients able to discontinue inhaled corticosteroids during the second six months of the study. The lack of benefits in some domains of the disease (e.g., lung function or symptoms) and some age groups (e.g., adults) does not exclude the possibility of benefits in other domains (such as prevention of exacerbations) and in other age groups. A large randomized double-blind placebo-controlled trial in children at high risk of severe exacerbations (Preventing asthma exacerbations by avoiding mite allergen-PAXAMA) showed that significantly fewer children who received mite-impermeable bed encasings attended hospital with asthma exacerbation compared to the placebo group in the 12-month follow-up period. The risk of hospital presentation was 45% lower in the Active compared with the Placebo group ($p=0.006$) (Figure 44).⁵⁴⁷ The effect of intervention was highest in children younger than 11 years, mono-sensitized to mite, living in nonsmoking households, and among children requiring more controller medication.

For pet-sensitized pet owners with allergic airway disease in whom this allergy is contributing to their symptoms, a double-blind, randomized study of pet removal is not feasible. One small nonrandomized, nonblinded study among pet-allergic patients with asthma indicated that pet removal from home reduced airway responsiveness.⁵⁴⁸ For such patients, the advice based on common sense and

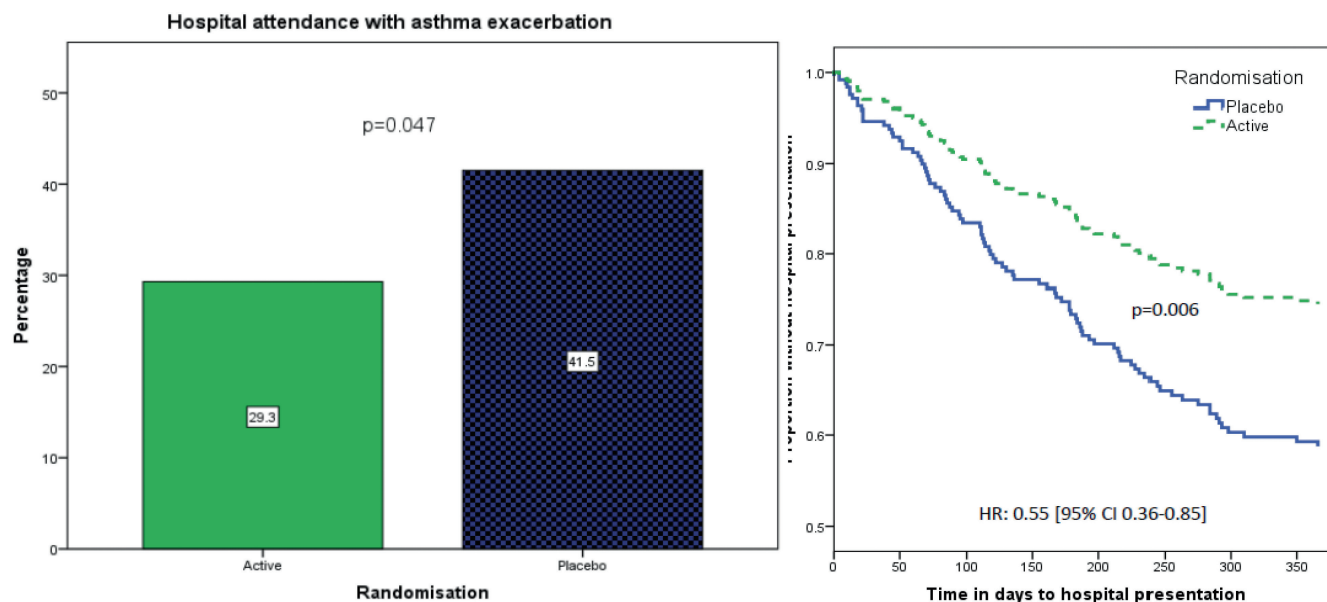


FIGURE 44 Proportion of children who suffered one or more severe exacerbation during the 12 month-follow up period in PAXAMA study (for all children who completed 12 months Follow up, $n=241$) Results are shown for one or more hospitalizations or emergency department visits requiring systemic corticosteroids because of an asthma exacerbation, and time to first hospitalizations or ED visit because of severe exacerbation of asthma. Active covers (mite-impermeable) (green line) and Placebo covers (blue line). Adapted from ⁵⁴⁷ with permission

clinical experience is to remove the pet from home. Studies of multifaceted interventions tailored towards patients' individual needs reported compelling evidence of improvement in asthma control and are recommended by the U.S. National Asthma Education and Prevention Program expert panel working group.⁵⁴⁹

Allergen avoidance in the prevention of allergic disease

Clinical outcomes reported to date by the primary prevention studies are inconsistent. In the Isle of Wight study, allergen avoidance from birth reduced mite sensitization and asthma by age 18 years, while in contrast the Manchester study reported an increase in mite sensitization.^{550,551} Some intervention studies reported no effect of allergen avoidance. Given such heterogeneity, much longer follow-up and more detailed analyses are required before we can draw conclusions and give meaningful clinical advice.

5 - Harmonization of Allergen Measurement

Harmonization of allergen measurements is required for the comparability of results between analytical laboratories using different methods, often with different analytical responses to the targeted allergens. Reporting units may also differ between laboratories. The goal of allergen standardization and harmonization is to reduce uncertainty and to validate method performance. Several factors may add to uncertainty in the qualitative and/or quantitative determination of allergens in foods, environmental samples, and diagnostic and therapeutic preparations (summarized in Table 11). These factors may be related to the selected method and sample preparation procedure or may be attributable to intrinsic properties of the

target allergens, including their molecular stability and consistency in the investigated sample.⁵²⁶

Antibody-based immunoassays (e.g., ELISA) and physicochemical mass spectrometry are considered as direct methods for measurement of allergenic proteins. By contrast, the detection of nucleic acids as surrogate target molecules, using nucleic acid amplification techniques (NAT), such as PCR are indirect and assume that coexistence of DNA and allergens in the sample is consistent. The NAT methods can be used to verify the biologic identity of source materials for allergen preparations. However, in most cases for the measurement of allergenic proteins, direct methods are preferred. Both ELISA and MS methods usually detect certain epitopes and peptides, respectively, on the allergen molecule.⁵²⁶ These structures must be (made) available and preserved by efficient sample preparation. Specific processes occurring in the environment or that are required to produce the sample may affect allergen integrity. The allergen preparation used for method calibration should be as similar as possible in its composition and presentation compared with the allergen that is measured in a sample. In real-life, this often is hard to achieve. Moreover, depending on the choice and specific type of method and detection modes, differences in the quantitative response to the allergen between the calibrator and sample may result in varying measurement results. Methods often apply different reporting units, further complicating comparability of results between different methods unless appropriate conversion factors are available.⁵²⁶

Compared with environmental samples or food, harmonization/standardization of molecular allergen measurements for pharmaceutical allergen preparations are the most advanced. Harmonization of

TABLE 11 Factors affecting the uncertainty of analytical methods for allergen determination in food, environmental samples, and diagnostic and therapeutic preparations.

Factors affecting uncertainty of results	Examples
choice of method	biochemical (NAT, ELISA), biophysical (MS), qualitative/ quantitative
type of specific method	real-time versus digital PCR, sandwich versus inhibition ELISA, MALDI-TOF versus Q-TOF MS, etc.
detection principle	amplification of DNA (PCR), non-covalent binding of epitopes by antibodies (ELISA), mass/charge ratio of peptides (MS)
selection and specificity of detection molecules (target analyte)	DNA stretch of allergenic source, allergen component, peptides of allergen component
selection of specific detection reagents or detection modes	primers in NAT, polyclonal versus monoclonal antibodies and epitope specificity in ELISA, multiple reaction monitoring versus high-resolution in MS; potential signal cross-talk in multi-analyte versus single analyte methods
reporting unit	arbitrary units; DNA copies; weight/volume or moles/volume, weight/weight or moles/weight of specific peptides or allergen components or total protein of allergen source per analysed sample
calibration (selected preparation)	specific stretch of or total DNA; total protein of allergenic source, selected allergen(s), selected peptide(s) of allergen(s)
differences in method response, depending on:	calibrator molecule, target molecule, variations in target molecule (isoform composition, impact of processing or environmental conditions), sample matrix interference, operator, selected detection devices/laboratory
correlation factors applied (e.g. from DNA to allergen; from epitope or peptide to allergen)	depending on type of calibration; known if applied for calculation after analysis or unknown if already included in read-out of commercial kit or report of service-lab
sample preparation	differences in quality and/or quantity of target analyte depending on extraction efficiency (PCR, ELISA, MS) and impact of additional reagents for sample preparation, e.g. purification (PCR) or enzymatic digestion (MS)

reporting units and the availability and use of certified reference materials and methods is essential to increase comparability of results between commercial allergenic products. Recent work on the

molecular standardization of pollen allergens through the BSP090 project is a good example of this approach. The two major allergens from birch pollen and from timothy grass pollen, recombinant Bet v 1 and Phl p 5, have been made available as European Pharmacopoeia (Ph. Eur.) chemical reference substances through the European Directorate for the Quality of Medicines & Health Care (EDQM).⁵⁵² Their use has so far not become mandatory.⁵⁵³ The current Ph. Eur. Monograph on Allergen Products allows allergen-specific reference standards to be used, when available. In addition to validated reference materials, two allergen-specific ELISA methods for Bet v 1 and for Phl p 5, were evaluated in international ring-trials through EDQM.^{372,552,554} The implementation of these protocols as general chapters for inclusion in the Ph.Eur. is in progress.⁵⁵³ Standardization and harmonization of test methods in the field of environmental food allergen analysis needs further development. A report on health-based guidance values for allergens in foods by the ad hoc FAO-WHO expert consultation group recommends that test methods report results in mg allergenic ingredient protein/kg of food (<https://www.fao.org/3/cb6388en/cb6388en.pdf>, accessed 9Feb2022). However, this recommendation may need to be modified to consider allergen detection methods used for verification of food allergen labeling requirements that measure molecular allergen components. Currently, test results are often converted to total protein of the allergenic food by calibration or calculation.⁵²⁶ This allows for comparison of the analytical result with suggested protein reference doses, such as provided by VITAL®, the Australian initiative for voluntary incidental trace allergen labelling and based on clinical reactivity in food challenge studies, at or below which voluntary labelling of noningredient allergen cross-contact is unnecessary for the protection of allergic consumers.⁵⁵⁴

In the field of food allergen risk assessment and labeling, multi-center collaborative studies and ring trials are needed to develop consensus guidelines for use of MS and other allergen specific methods. Harmonized quantitative MS methods are being developed as part of the ThRAIL project.⁵⁵⁵ Official Methods Board of the German Government has also launched a new Working Group to standardize MS methods to detect allergens in foods through multi-laboratory validation studies.⁵⁵⁶ There is also a need for more extensive development of certified reference materials for allergen analysis in foods, which will play a key role in allowing harmonization of test methods results both across different platform technologies and between laboratories. Moreover, sample collection can be ad hoc, which makes interpretation of test results complex and uncertain. Consequently, statistically validated sampling plans need to be developed.

In summary, for a few of the many major allergens that are relevant in foods, environmental samples and medicinal allergen products, reference materials and harmonized protocols for methodology are available. Availability of commonly agreed or mandatory reference materials, harmonized protocols for methodology, including commonly agreed reporting units and sampling plans are needed for the inter-laboratory and cross-product comparability of single allergen measurement results.

6 – Case studies

Case Study I

The US National Health and Nutrition Examination Survey (NHANES) 2005-6.

- A survey of allergen exposure in US homes that were representative of the general US population⁵⁵⁷.
- A mixed bed and bedroom floor dust sample was obtained from ~7,000 homes.
- Samples were analysed using a MARIA 9-plex array for Der p 1, Der f 1, Mite Group 2, Fel d 1, Can f 1, Mus m 1, Rat n 1, Bla g 2, Alt a 1. Over 56,000 data points.
- >90% of homes had detectable levels of 3 allergens, usually Fel d 1, Can f 1, Mus m 1, Der p 1, or Der f 1.
- 15.8% had detectable levels of 7 or more allergens.
- Individual allergen levels in homes varied according to the participants' race/ethnicity, poverty index ratio, age and presence of children in the household. Regional variation, climate factors and level of urbanization also affected dust mite, cockroach and pet allergen levels (see refs for full details).

Case Study II

The Schools Inner-City Asthma Study (SICAS) 2008-13

- A study of allergen exposure in 37 inner-city elementary schools in the northeastern US.⁵⁵⁸
- ~1,100 dust/air/table wipe samples were collected from the school environment and children's homes.
- Samples were by MARIA 9-plex array for Der p 1, Der f 1, Mite Group 2, Fel d 1, Can f 1, Mus m 1, Rat n 1, Bla g 2, Alt a 1 and for endotoxin. Over 11,000 data points.

- Mus m 1 was the most common allergen found in schools and homes, with higher allergen levels found in settled dust from schools (which was highly correlated with airborne Mus m 1 levels)
- In a follow up study (SICAS II), ~450 dust/table wipe samples collected from the school environment and homes were analysed for food allergens:
- Samples were analysed by MARIA for Foods 7-plex array for Ana o 3, Ara h 3, Ara h 6, Bos d 5, Cor a 9, Gal d 1, Gal d 2.
- Milk, peanut and egg allergens were readily detectable in floor samples and table wipes in elementary schools, but not at higher levels than those found in children's homes.⁵²³

7 – Salient points

- Molecular allergen exposure assessment is a critical process for the investigation of environmental and food allergens and their relationship to allergic diseases.
- State-of-the-art multiplex technologies, including immunoassays and MS, will facilitate high throughput exposure assessment based on specific allergens that will enable thresholds for risk assessment to be established.
- Molecular exposure assessments, coupled with analyses of other environmental factors and genetic predisposition, will facilitate comprehensive epidemiologic and population studies of the role of the exposome in causing allergic respiratory diseases.
- Harmonization of molecular exposure assessments is urgently needed. This will require mutual collaboration between technology providers, academic and clinical investigators, industry and regulatory authorities to design and execute multi-center studies for validation of sampling plans and analytical detection methods.

B01 - Tree pollen allergy

Enrico Scala, Alessandro Maria Marra, Riccardo Asero

Highlights

- Cup a 1 reactivity is the specific marker for a sensitization to the Cupressaceae family.
- PR-10 molecules (Bet v 1 like) are the major allergens in Fagales pollen often associated with an oral allergy syndrome.
- Ole e 1 is the most common sensitizing molecule in olive pollen.
- Pla a 1 and Pla a 2 may serve as a marker of primary sensitization to plane tree pollen.

1 - The allergen sources

Among over 400,000 plant species,⁵⁶⁰ about 100 flowering (Angiospermae) and nonflowering (Gymnospermae) trees can induce specific sensitization in predisposed individuals. Besides grass pollen and house dust mites, tree pollens belong to the most important respiratory allergen sources. The knowledge of the taxonomical relationship between different tree species allows the prediction of cross-reactivity between closely related plants, which share homologous molecules not found in unrelated plants. The trees most commonly causing allergy belong to the orders Fagales (alder, beech, birch, hazelnut, oak), Lamiales (ash, privet, olive, lilac), Pinales (cypress, Japanese cedar, juniper), and Proteales (plane tree, sycamore).^{559,561}

The geographical distribution of allergenic plants drives patients' sensitization profiles, as a consequence of different local pollen exposure. For instance, in the Mediterranean area, as well as in regions with a Mediterranean climate such as North and South Africa, North and South America, and Australia, trees belonging to the order Lamiales (i.e., olive tree) or Pinales (i.e., cypress tree) are mainly found, whilst Fagales trees play a role as allergen sources mostly in temperate climate regions such as Northern and Central Europe, North America, East Asia and Northwest Africa.⁵⁶²

The order **Fagales** encompasses seven distinct families, but the two most frequently implicated in tree-pollen allergies are (i) *Betulaceae* including the genera *Alnus* (alder), *Betula* (birch), *Carpinus* (hornbeam), *Corylus* (hazel), and *Ostrya* (hop hornbeam), and (ii) *Fagaceae*, comprising the genera *Castanea* (chestnut), *Castanopsis* (chinkapin), *Chrysolepis* (chinquapin), *Fagus* (beech), *Lithocarpus* (tanoak), and *Quercus* (oak)⁵⁶³ (Figure 45). A high degree of allergenic cross-reactivity among allergens from these plants distributed all over the world has been demonstrated. Birch, followed by alder and hazel, represents the most relevant cause of tree pollen allergy within this order. The flowering period of birch begins at the end of March in Western Europe, from the beginning to mid-April in Central and Eastern Europe and from late April to late May in Northern Europe.⁵⁶⁴ From 1 to 3 weeks after the beginning of the season higher amounts of pollen in the atmosphere are recorded, and the extent of the pollen season is extremely dependent on weather conditions, and thus ranges from 2 to 8 weeks.⁵⁶⁴ An alternation of low and high pollen production per year has been detected. Hazel and alder florescence starts early from December to April, is followed by birch, hornbeam and hop hornbeam and then by oak and beech

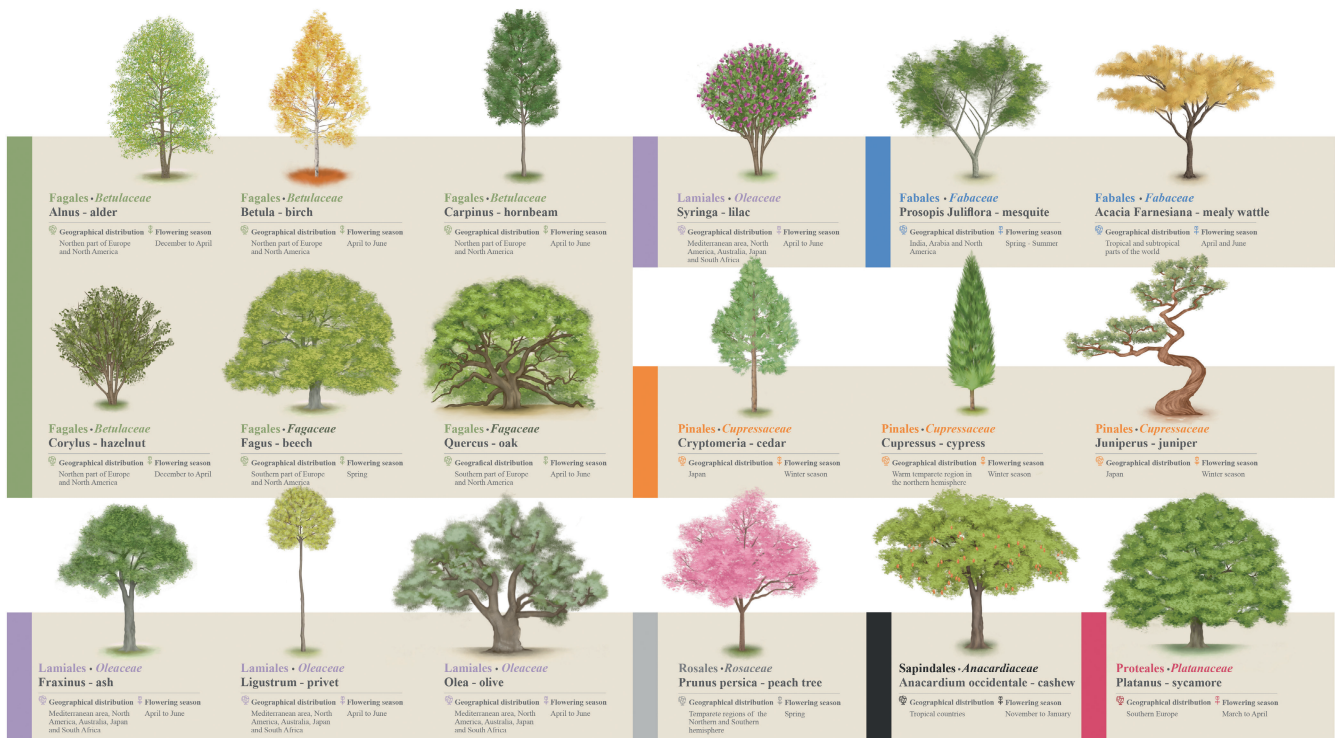


FIGURE 45 Taxonomy, geographic distribution, and flowering seasons of the most relevant tree pollen allergen sources

in spring. Chestnuts shed pollen in June and July in Western and Central Europe.

Trees from the family *Oleaceae*, order **Lamiales**, grow on all 5 continents and are among the most important causes of respiratory allergy in the Mediterranean area as well as in some areas of North America, Australia, Japan, and North and South Africa, where these trees are intensively cultivated.⁵⁶⁵ The *Oleaceae* family comprises 4 main genera: olive (*Olea europea*), European ash (*Fraxinus excelsior*), lilac (*Syringa vulgaris*), and common privet (*Ligustrum vulgare*), all able to cause IgE sensitization⁵⁶⁶ (Figure 45). The pollination period ranges from April to June in warmer regions, and the occurrence of olive tree allergy among patients suffering from tree pollen allergy is about 30–40% in Italy.^{567,568} Ash pollen season is during winter-time, rather similar to the birch pollen season, and is very relevant in Central Europe (Austria, North and East of France, Switzerland up to 30% prevalence of pollen allergic patients).

In Mediterranean regions trees of the *Cupressaceae* family (Figure 43) from the order **Pinales** are widely spread. Wind pollination of cypress trees occurs during the winter season, when no other allergenic plants flower, and accounts for up to 40% of the total pollen count in Mediterranean countries.⁵⁶⁹ Cypress tree florescence covers about 30–40 days, from January to April, showing a high variability from year to year, depending on weather conditions, causing difficulty in identifying the beginning and length of pollen season. The high degree of cross-reactivity found among *Cupressaceae* trees (cypress, juniper, and cedar), which have somewhat different but overlapping pollination periods, could extend the cypress pollen season from December to March.⁵⁷⁰

Trees of the Plane-tree family (e.g., *Platanus acerifolia*), from the order **Proteales**, are common species widely spread in Southern Europe, with a short but intense pollen season from March to April, characterized by high pollen counts, reaching one hundred billion pollen grains per tree only a few days after the florescence time. Clinical surveys have acknowledged plane trees as a major cause of pollen with sensitization rates ranging from 8 to 17% in exposed populations. Annual airborne pollen counts differ based on weather conditions but also as a function of human activity, mainly pruning since plane trees or sycamores are widely used for ornamental purposes.⁵⁷¹ Temperature, but not rainfall, is the weather parameter mainly affecting the *Platanus* pollen season, influencing both start-date and daily pollen counts.

In subtropical regions mesquite (*Prosopis juliflora*) and *Acacia farnesiana* (*Vachellia farnesiana*) (Needle bush), trees belonging to the order **Fabales** have been acknowledged as a clinically relevant allergen in North America, India, and the Arabian Peninsula.^{572,573}

2 – Allergen families and allergenic molecules

Pollen from **Fagales** trees is one of the most frequent causes of winter/spring respiratory allergy in the temperate areas of the Northern hemisphere. This order includes two main families (*Betulaceae* and *Fagaceae*) comprising different trees characterized

by a rather limited number of homologous, cross-reacting allergens⁵⁷⁴ (Table 12). Moreover, pollen from birch has shown the ability to suppress innate antiviral immunity, independent of allergy.^{575,576}

Pathogenesis-related-protein group 10 (PR-10) molecules (i.e., Bet v 1 and homologous allergens)⁵⁷⁷ are the major allergens in Fagales pollen and are recognized by virtually all allergic patients, thus representing the major cause of clinical allergy (see also Chapter C02), which includes a large group of aeroallergens and common food allergens. Several PR-10 family members have been described to date within tree pollen belonging to the Fagales order ([i] *Betulaceae*: Aln g 1 from alder, Bet v 1 from birch, Car b 1 from hornbeam, Cas s 1 from chestnut and Cor a 1 from hazel, [ii] *Fagaceae*: Fag s 1 from European beech, Ost c 1 from hop hornbeam, Que a 1 from white oak, Que i 1 from Sawtooth oak, Que i 1 from Holly Oak, and Que m 1 from Mongolian oak).

In addition to PR-10 proteins, several other allergens have been described.

- (i) Profilins (e.g., Bet v 2 from birch pollen or Cor a 2 from hazel pollen)⁵⁷⁸ [20] are pan-allergens (see Chapter C01) present in the whole plant kingdom. Profilins are recognized by 10–20% of patients primarily sensitized to birch pollen, but this proportion is higher in areas where grass pollen represents the primary sensitizer. The clinical relevance of profilin as a respiratory allergen is variable.⁵⁷⁹ Profilins may cause secondary plant food allergy to various fruits and vegetables (see Chapter C01).
- (ii) Polcalcin-like proteins (calcium-binding proteins; e.g., Bet v 3 and Bet v 4 from birch, and Aln g 4 from alder) are pollen pan-allergens, which generally sensitize less than 10% of pollen-allergic individuals. They cross-react with homologous pollen allergens from botanically unrelated species. The clinical relevance is variable and often limited⁵⁷⁹: in a retrospective study of 854 Italian patients with birch pollen sensitization, Bet v 1 sensitization significantly decreased from the North (95.41%) to the South (58.56%) of the country, whereas both profilin and polcalcin reactivity significantly increased from Northern to Southern Italy⁵⁸⁰;
- (iii) phenyl-coumaran benzylic ether reductases or isoflavone reductases (e.g., Bet v 6 from birch, Cor a 6 from hazel, Ole e 12 from olive) are minor allergens that are involved in plant defence reactions, showing a sensitization rate of about 32% among birch allergic people⁵⁸¹;
- (iv) cyclophilin (Bet v 7 from birch) is a minor, potentially cross-reactive, allergen;
- (v) pectin methylesterase;
- (vi) glucanase;
- (vii) thaumatin-like protein; and
- (viii) Glutathione-S-transferase (GST) (Bet v 8 from birch) are other minor allergens.⁵⁸²

Olive pollen allergy is caused by Ole e 1 allergy in about 70% of cases (Table 13). The Ole e 1-like protein family comprises several

TABLE 12 The prevalence data shown in the table are derived from www.allergen.org for each allergen indicated.

Allergenic molecule	Biochemical name	Prevalence among patients	MW (in kDa)
<i>Alnus glutinosa</i> (Alder)			
Aln g 1	PR-10, Bet v 1 family member	100%	18
Aln g 4	Polcalcin	18%	6
<i>Betula verrucosa</i> (<i>Betula pendula</i>) (European white birch)			
Bet v 1	PR-10, Bet v 1 family member	95%	17
Bet v 2	Profilin	22%	15
Bet v 3	Polcalcin-like protein	10%	24
Bet v 4	Polcalcin	5%	7
Bet v 6	PhenylCoumaran benzylic ether reductase	32%	35
Bet v 7	Cyclophilin	21%	18
Bet v 8	Glutathione-S-transferase	13%	27
<i>Carpinus betulus</i> (Hornbeam)			
Car b 1	PR-10, Bet v 1 family member		17
<i>Corylus avellana</i> (Hazel)			
Cor a 1	PR-10, Bet v 1 family member	100%	17
Cor a 2	Profilin		14
Cor a 6	Isoflavone reductase homologue		35
Cor a 10	Luminal binding protein		70
<i>Ostrya carpinifolia</i> (European hophornbeam)			
Ost c 1	PR-10, Bet v 1 family member		
<i>Castanea sativa</i> (Chestnut)			
Cas s 1	PR-10, Bet v 1 family member	100%	22
<i>Fagus sylvatica</i> (European beech)			
Fag s 1	PR-10, Bet v 1 family member		17
<i>Quercus Acutissima</i> (Sawtooth oak)			
Que ac 1	PR-10, Bet v 1 family member	92%	17
Que ac 2	Profilin		16
<i>Quercus alba</i> (White oak)			
Que a 1	PR-10, Bet v 1 family member	64%	17
<i>Quercus mongolica</i> (Mongolian oak)			
Que m 1	Pathogenesis protein 10	92%	17
<i>Quercus ilex</i> (Holly Oak)			
Que i 1	PR-10, Bet v 1 family member	55%	21

other allergenic glycosylated proteins from tree pollen (Fra e 1, Lig v 1, and Syr v 1), whose glycan moieties are involved in their allergenic properties⁵⁸³ Besides Ole e 1, several other molecules

have been identified, and a biological function can be associated with most of these molecules, such as actin-binding protein (the profilin Ole e 2), polcalcin (Ole e 3 and Ole e 8), glucanase (Ole e 9

TABLE 13 The prevalence data shown in the table are derived from www.allergen.org for each allergen indicated.

Oleaceae			
Allergenic molecule	Biochemical name	Prevalence among patients	MW (in kDa)
<i>Fraxinus excelsior</i> (Ash)			
Fra e 1	Ole e 1-like protein family member	87%	20
<i>Ligustrum vulgare</i> (Privet)			
Lig v 1	Ole e 1-like protein family member	58%	20
<i>Olea europaea</i> (Olive)			
Ole e 1	Common olive group 1	90%	16
Ole e 2	Profilin	50%	15
Ole e 3	Polcalcin-like protein (4 EF-hands)		9
Ole e 4		80%	32
Ole e 5	Superoxide dismutase [Cu-Zn]	35%	16
Ole e 6		15%	10
Ole e 7	non-specific lipid transfer protein	47%	9
Ole e 8	Polcalcin-like protein		21
Ole e 9	1,3- β glucanase	68%	46
Ole e 10	X8 domain containing protein	90%	11
Ole e 11	Pectin methylesterase		39.4
Ole e 12	Isoflavone reductase	4-33%	37
Ole e 13	Thaumatococin	13%	23
Ole e 14	Polygalacturonase	13%	46.5
Ole e 15	Cyclophilin	27%	19
<i>Syringa vulgaris</i> (Lilac)			
Syr v 1	Ole e 1-like protein family member	90%	20
Syr v 3	Polcalcin	90%	8.9
Fabaceae			
Allergenic molecule	Biochemical name	Prevalence among patients	MW (in kDa)
<i>Acacia farnesiana</i> (<i>Vachellia farnesiana</i>) (Needle bush)			
Aca f 1	Ole e 1-like protein family member	47%	17
Aca f 2	Profilin		14.3
<i>Prosopis juliflora</i> (Mesquite)			
Pro j 1	Ole e 1-like protein family member	56%	18
Pro j 2	Profilin	45%	14.3

and its probable degradation product Ole e 4), superoxide dismutase (Ole e 5) and lipid transfer protein (Ole e 7). Olive tree Ole e 7, shares less than 20% of amino acid sequence with Pru p 3.⁵⁶⁷ Even though the homology at the primary sequence level is low, the tertiary structure of nsLTP is rather similar. Immunologically they seem to be distinct, which is also true for Par j 2, the nsLTP from pellitory that does not cross-react with, e.g., Pru p 3 (see Chapter C03).

The glucanase Ole e 9, despite representing less than 0.3% of crude olive pollen content,⁵⁸⁴ induces sensitization in about 50% of patients in some Mediterranean regions with high olive pollen counts during pollen season.^{567,585} Patients sensitized to Ole e 9 seem to be at higher risk of suffering adverse side reactions during immunotherapy.⁵⁸⁵ Ole e 7 and Ole e 9 IgE recognition have been recently associated with local or systemic reactions to food,⁵⁸² and

atopic dermatitis,⁵⁸⁶ respectively. Ole e 10 (X8 domain-containing protein) and the pectin methyltransferase Ole e 11 are two other major olive pollen allergens.

So far, both Ole e 1-like proteins (Aca f 1 and Pro j 1) and profilins (Aca f 2 and Pro j 2) have been identified and characterized, as relevant allergens in *Acacia farnesiana* and mesquite (*Prosopis juliflora*) tree pollen allergy, respectively.⁵⁸⁷⁻⁵⁸⁹

In the Cypress family, two main groups of proteins have been identified: the pectate lyases and the polygalacturonases⁵⁹⁰ (Table 14). The highly related (95.1% sequence identity) pectate lyases Cup a 1 and Cup s 1 are found in the Mediterranean area, whilst Cry j 1 and Cha o 1 are mainly found in Japan, sharing lower sequence identity (78.6%).

The polygalacturonases, Cha o 2, Cry j 2, and Jun a 2 are also major allergens of Pinales pollen, showing high levels of sequence identities (71%-82%).

Recently cypmaclein, an allergen belonging to the Gibberellin regulated protein (GRP) family, has been isolated from the cypress pollen⁵⁹¹ (Table 14). GRP sensitization is important to define a subset of patients with allergy to cypress pollen and severe peach allergy caused by Pru p 7 (Peamaclein) co-recognition²³¹ (see Chapter C09). Peamaclein sensitization prevalence seems to be quite frequent in France²³⁰ but rare in Italy.⁵⁹²

The most important allergen from London plane tree (*Platanus acerifolia*) pollen is Pla a 1,⁵⁹³ which has an invertase inhibitor function as has the homologous Pla or 1 from *Platanus orientalis*

TABLE 14 The prevalence data shown in the table are derived from www.allergen.org for each allergen indicated.

Cupressaceae			
Allergenic molecule	Biochemical name	Prevalence among patients	MW (in kDa)
<i>Chamaecyparis obtusa</i> (Japanese cypress)			
Cha o 1	Pectate lyase	97.5%	40.2
Cha o 2	Polygalacturonase	82.5%	45
Cha o 3	Cellulase (glycosyl hydrolase)	87.5%	63
<i>Cryptomeria japonica</i> (Sugi)			
Cry j 1	Pectate lyase	>90%	41-45
Cry j 2	Polygalacturonase	>90%	45
Cry j 7	Gibberellin-regulated protein	100%	7
<i>Cupressus arizonica</i> (Cypress)			
Cup a 1	Pectate lyase	100%	43
<i>Cupressus sempervirens</i> (Common cypress)			
Cup s 1	Pectate lyase		43
Cup s 2	Polygalacturonase	61.30%	43
Cup s 3	Thaumatococin-like protein		34
Cup s 7	Gibberellin-regulated protein		9.5
<i>Juniperus ashei</i> (Mountain cedar)			
Jun a 1	Pectate lyase	71.4%	43
Jun a 2	Polygalacturonase	100%	43
Jun a 3	Thaumatococin-like protein	43%	30
Jun a 7	Gibberellin-regulated protein	100%	7
<i>Juniperus oxycedrus</i> (Prickly juniper)			
Jun o 4	Polcalcin-like protein	15%	29
<i>Juniperus virginiana</i> (Eastern red cedar)			
Jun v 1	Pectate lyase	46%	43
Jun v 3	Thaumatococin-like protein		34

(Table 15). Pla a 2 and Pla or 2 are major allergens displaying a polygalacturonase activity. The plane tree Pla a 3 belongs to the family of nonspecific lipid transfer proteins, showing 58.3% sequence identity with the nsLTP Pru p 3 from peach.⁵⁹⁴

Cashew tree pollen appears to be an important cause of rhinoconjunctivitis symptoms in the northeast of Brazil.⁵⁹⁵ Peachtree pollen allergy may be associated with respiratory symptoms in adolescents living in regions where peach trees are grown.⁵⁹⁶

3 – Sensitization to individual molecules and their clinical relevance

In Europe, the prevalence of positive skin prick test to birch pollen allergens ranges from 5% in The Netherlands to 54% in Switzerland, while Scandinavian countries have the highest number of patients with exclusive sensitization to Bet v 1.⁵⁹⁷ Bet v 1-specific IgE levels are not predictive for the development of pollen-related bronchial asthma. PR-10 proteins defend plants against fungi and other micro-organisms. Their homologues are also present in a large number of plant-derived foods, and thus frequently cause IgE cross-sensitization and consequently plant-food allergy (oral allergy syndrome, in most cases). For this reason, up to 70% of patients with sensitization to PR-10 proteins complain about oral symptoms following the ingestion of certain plant foods (e.g., apples, carrots, nuts and stone fruit) (see chapter C02). This indicates from a clinical point of view the need to check at least one representative allergen from both the *Betulaceae* family (i.e., Bet v 1 from birch) and the *Fagaceae* family (i.e., Que a 1 from oak) in all patients in the daily clinical practice. Interestingly, Pru p 9, also belonging to the PR-10 family, is responsible for the respiratory symptoms in patients allergic to peachtree pollen.⁵⁹⁸

The assessment of IgE reactivity to a panel of PR-10 proteins also in birch-free areas may lead to disclosing peculiar relationships between clinical phenotypes and sensitization profiles, such as the association among Bet v 1-, Cor a 1-, and Aln g 1-specific IgE recognition and the occurrence of respiratory symptoms.⁵⁹⁹

Also, *Olea europaea* reactivity seems to be clinically characterized by rhino-conjunctivitis more than bronchial asthma, but a dramatic outbreak of asthma attacks may occur during a thunderstorm in the olive pollen season. Moreover, in olive pollen patients, polysensitization is more common than mono-sensitization. Reactivity to other genera belonging to the *Oleaceae* family, i.e., *Fraxinus excelsior* or *Ligustrum vulgare*, is relevant in several regions in Central and Southern Europe.⁶⁰⁰ Olive tree Ole e 1 is a 145 amino acid protein sharing both significant sequence identity (82.76% of identity with 120 identical positions and 19 similar positions, as obtained by comparing the single sequences via <https://www.uniprot.org/align/>) and IgE cross-reactivity with all the other related trees belonging to the Olive family (Fra e 1 from ash, Lig v 1 from privet and Syr v 1 from lilac).⁶⁰¹ Several Ole e 1-like proteins have been described in goosefoot (*Chenopodium album*, Che a 1), timothy (*Phleum pratense*, Phl p 11), rye-grass (*Lolium perenne*, Lol p 11), English plantain (*Plantago lanceolata*, Pla l 1) and prickly saltwort (*Salsola kali*, Sal k 5), but the real clinical cross-reactivity of these molecules, not belonging to the olive family, with Ole e 1 is somewhat questioned.⁶⁰⁰ As already mentioned, the major allergens of *Acacia farnesiana* and mesquite (*Prosopis juliflora*) tree are both “Ole e 1 like proteins” (respectively Aca f 1 and Pro j 1): interestingly, Aca f 1 from *Acacia farnesiana* has overall 45.3% of identity with Ole e 1 (68 identical and 41 similar positions).

Patients allergic to cypress pollen may represent 30% of pollen-sensitized subjects in some areas⁶⁰² and 42% in central and southern Italy.^{568,603} Cypress pectate lyase allergy generally causes seasonal allergic rhinitis, and a very low occurrence of bronchial asthma in sensitized patients has been reported in the literature,⁶⁰⁴ but since asthma is a genetically determined condition, it depends more on the degree of sensitization and exposure rather than on the intrinsic characteristics of the allergens. High sequence identity and IgE cross-reactivity among the pectate lyases belonging to the *Cupressaceae* family (Cha o 1, Cry j 1, Cup a 1, Cup s 1, Jun a 1, Jun c 1, Jun o 1 and Jun v 1) is observed, with an overall 70% of similarity (262 identical and 74 similar amino acid positions, as obtained by comparing the single sequences via <https://www.uniprot.org/align/>).

TABLE 15 The prevalence data shown in the table are derived from www.allergen.org for each allergen indicated.

Platanaceae			
Allergenic molecule	Biochemical name	Prevalence among patients	MW (in kDa)
<i>Platanus acerifolia</i> (London plane tree)			
Pla a 1	Putative invertase inhibitor	87.5%	18
Pla a 2	Polygalacturonase	83%	43
Pla a 3	Non-specific lipid transfer protein type 1	45%	10
<i>Platanus orientalis</i> (Oriental plane)			
Pla or 1	Putative invertase inhibitor	15.8%	18
Pla or 2	Polygalacturonase	26.3%	42
Pla or 3	Non-specific lipid transfer protein type 1	26.3%	11

A 50% sequence identity with the ragweed allergenic pectate lyase Amb a 1 without evidence of cross-reactivity has been described.⁶⁰⁵

In the case of polygalacturonases an IgE cross-reactivity among the homologous allergens belonging to Cupressaceae families (Cri j 2, Cha o 2, Cup a 2, Cup s 2 and Jun a 2) has been observed.⁵⁶¹ Polygalacturonase belonging to timothy grass (Phl p 13) showed also considerable (up to 40%) sequence identity with Cri j 2, without measurable cross-reactivity.⁶⁰⁶

Plane tree Pla a 1 has a 98% identity with Pla or 1. Pla a 2 and Pla or 2 are other major allergens displaying a polygalacturonase activity with only 35% of sequence identity and no cross-reactivity with *Cryptomeria japonica* Cry j 2.⁵⁹⁴ The plane tree Pla a 3 exhibits approximately 50% sequence identity with peach Pru p 3, and is therefore possibly implicated in plant food-pollen co-sensitization.⁶⁰⁷

Clinical relevance and patterns

Certain proteins are restricted to a given allergenic biological source, and therefore can be considered as “marker allergens” or a genuine “signature” clinically useful for the identification of patients for whom immunotherapy with a given allergen extract is appropriate. For instance, in the tree pollen model, the major birch pollen, Bet v 1, can identify individuals allergic to the *Betulaceae* family. The olive tree major allergen, Ole e 1, detects sensitization to the *Oleaceae* family, the cypress pollen major allergen, Cup a 1, reveals sensitization to the *Cupressaceae* family, and Pla a 1 detects sensitization to the *Platanaceae* family. Other allergens exhibit a large cross-reactivity and their distribution is not restricted to a given taxonomical order, but they are rather distributed throughout the entire plant kingdom and are therefore found in all tree pollen families (the so-called pan-allergens). Polcalcin-like proteins and profilins are typical examples of pan-allergens. In the case of polcalcin-like proteins (see Chapter C06), also known as EF-hand calcium-binding allergens (i.e., alder Aln g 4, hornbeam Car b 4, birch Bet v 4, beech Fag s 4, and oak Que a 4), IgE recognition is often associated with multiple pollen (grass, weed and tree) sensitization,⁶⁰⁸ a lower response to immunotherapy, and an association with bronchial asthma.⁶⁰⁹ Patients sensitized to profilins (see Chapter C01) (e.g., Aln g 2 from alder, Bet v 2 from birch, Car b 2 from hornbeam, Cas s 2 from chestnut, Cor a 2 from hazel, Fag s 2 from beech and Que a 2 from oak) are not only reactors to a pan-allergen found in distinct sources but also true plant food multi-sensitized patients.⁶¹⁰ Pan-allergens reactivity could therefore cause a misleading interpretation if allergy testing is carried out only using allergenic extracts. A given patient could have positive extract-based tests to several tree pollen extracts, due to IgE recognition of both genuine and/or pan-allergens, or as a result of an IgE recognition of pan-allergens in the absence of a genuine reactivity to the marker allergens. Despite the high sequence identity observed among constituents of every single group of pan-allergens, testing of several pan-allergens could increase assay reliability and the identification of interesting clinical phenotypes, albeit in daily clinical practice a less expensive approach may often be necessary. Recently, GRPs (see Chapter C09) have turned out to be relevant allergens in multiple fruit allergic reactions, mainly from the *Rosaceae*

family, (i.e., peach, apricot or cherry), due to the high degree of cross-reactivity with the GRPs found in the cypress pollen.^{230,559}

IgE reactivity due to cross-reactive carbohydrate determinants (CCDs) (see Chapter A10) should also be ruled out, since all plant extracts can be weakly recognized by patients' IgE specific for CCDs, with no clinical significance.⁶¹¹ Interestingly, such reactivity does not affect the execution of the skin prick tests, since the IgE binding with the CCDs is not able to induce cutaneous mast cell degranulation. In (Figure 46), genuine markers of sensitization are indicated in green and pan-allergens found in the different pollens are coloured in red.

Clinical relevance

- Molecular markers of genuine reactivity: Cry j 1 (pectate lyase); Cup a 1 (pectate lyase); Aln g 1 (PR-10 protein); Bet v 1 (PR-10 protein); Cor a 1 (PR-10 protein); Ole e 1 (common olive group 1); Ole e 9 (beta-1,3-glucanase); Pla a 1 (putative invertase inhibitor); Pla a 2 (polygalacturonase).
- Pan-allergens: Profilin (Bet v 2), Polcalcin (Bet v 4), nsLTP (Ole e 7 and Pla a 3), and Gibberellin regulated protein (Cry j 7, Cup s 7, and Jun a 7). Check also the purified N-glycan from bromelain MUXF3 in the case of multiple tree pollen IgE reactivity, to rule out the possibility of CCD reactivity.

4 – Clinical Management

Allergen-specific immunotherapy (AIT) should be prescribed only when the clinical relevance of a given allergen source has been reliably demonstrated.⁶¹² In the presence of a multiple IgE sensitization, the first goal is to distinguish patients genuinely reactive from those misrecognizing a given biological source due to reactivity to pan-allergens. Another difficulty in identifying the primary sensitizing source occurs in several countries (i.e., Southern Europe) where overlapping of tree, weed or grass pollination periods takes place. Several molecules have been proposed as markers for the prediction of a better response to AIT: Ole e 1, Cup a 1, Bet v 1, Cor a 1 or Pla a 1 reactivity can be considered as specific signatures for a genuine tree pollen allergy.

Cup a 1 reactivity is the specific marker allergen for sensitization to the pollen of trees of the *Cupressaceae* family. Also, in this case, the high sequence identity, associated with a high degree of cross-reactivity among *Cupressaceae* family members, suggest the use of Cup a 1 as a representative marker of the entire family for both diagnostic testing and therapeutic approaches (Figures 46 and 47).

Bet v 1-sensitized individuals often experience an oral allergy syndrome due to the intake of food containing PR-10 proteins.

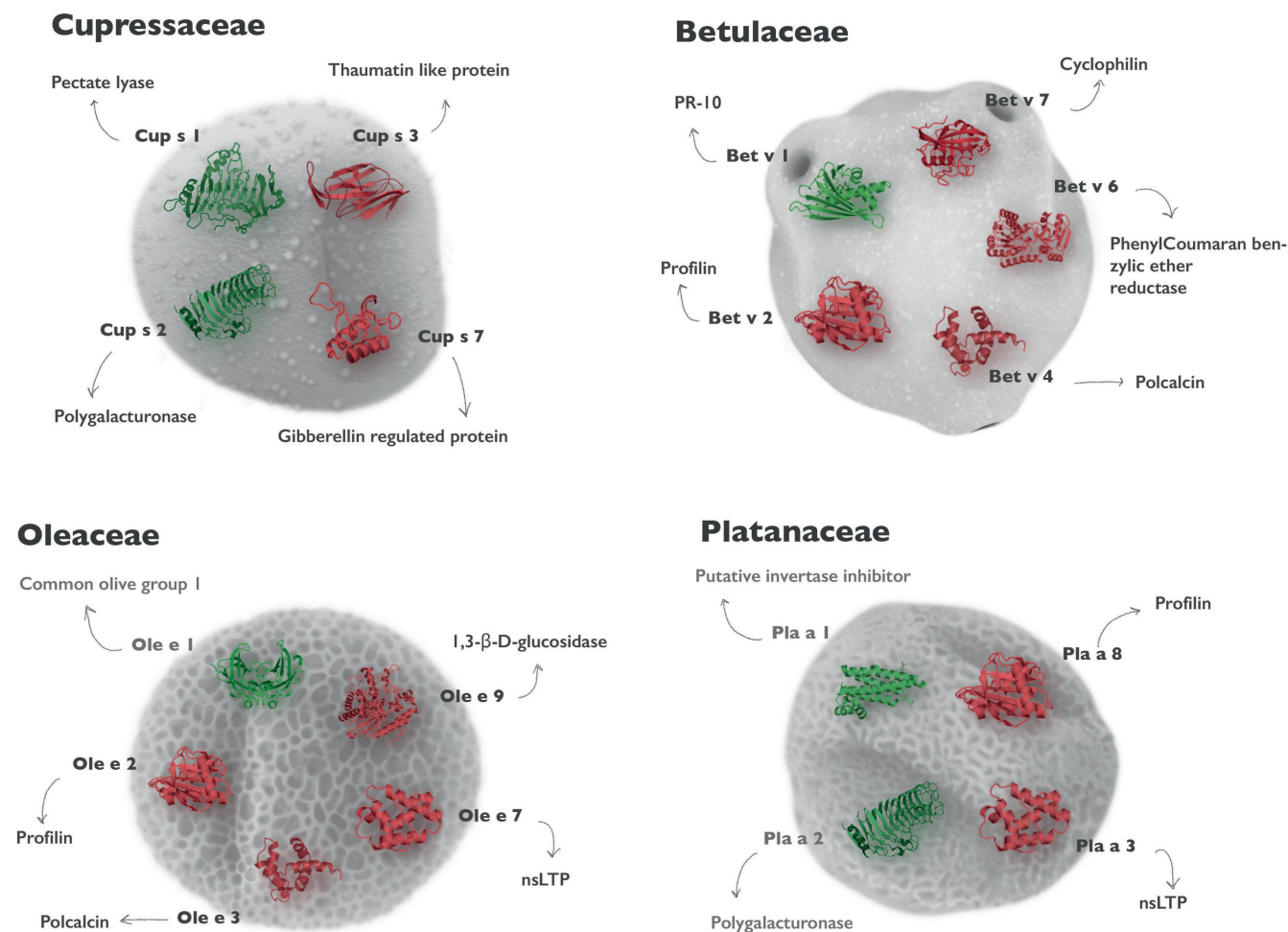


FIGURE 46 Overview of the clinically most relevant marker molecules of genuine sensitization (green) and pan-allergens (red)

It has been suggested that birch pollen AIT can improve not only pollen-related respiratory symptoms but also food-related adverse reactions,⁶¹³ but different outcomes without benefit are reported in other studies^{614,615} (see Chapter C02). AIT containing birch extracts can also be used to treat patients allergic to oak, given the cross-reactivity between Bet v 1 and Que a 1.⁶¹⁶

Ole e 1 is the most common sensitizing molecule in olive pollen. It is utilized in both diagnostic and therapeutic extracts for standardization purposes and can determine immunological changes after olive pollen AIT. On the other hand, due to the high degree of cross-reactivity among the Ole e 1-like proteins of the Oleaceae family, in olive-free areas, Ole e 1 reactivity could help to identify individuals reacting with ash or privet pollen as suitable for AIT.⁶¹⁷ In areas with heavy olive pollen exposure, Ole e 7 and Ole e 9 should be tested to identify patients with a more severe allergic phenotype.⁵⁶⁷

Pla a 1 and Pla a 2 may serve as a marker of primary sensitization to plane tree pollen, therefore useful for AIT selection, whilst the nsLTP Pla a 3 has been linked with sensitization to plant-food LTPs.^{592,594}

Profilin and polcalcin (see chapters C01 and C06) represent the major causes of cross-reactivity due to their highly conserved structure and ubiquitous distribution. Profilin or polcalcin-reactors

score positive to all tree pollen after extract-based diagnostic testing. Several allergens that are currently available for routine testing (profilins from birch, Bet v 2, and grass, rPhl p 12, and polcalcins from birch, rBet v 4, and grass, rPhl p 7), are marker molecules for the entire group of pan-allergens, excluding cypress and Parietaria profilins.⁶¹⁸ As a difference for LTP reactors, GRPs reactors score positive for Cypress on skin testing, but negative for the plane tree, mugwort, or olive tree.⁶¹⁹ IgE sensitization to pan-allergens, despite the ability to induce symptoms in sensitized patients, could affect AIT efficacy in the absence of species-specific molecules reactivity⁶¹² (Figure 47). Interestingly, most pan-allergen reactors are also co-sensitized to species-specific genuine molecules from different pollen sources,⁵⁹⁹ thus potentially require multiple pollen AIT to be successfully treated.

Cross-reactive carbohydrate determinants (CCDs) (see Chapter A10) do not behave as allergens *in vivo* and are therefore clinically insignificant,⁵⁰ but the presence of IgE to CCDs could lead to a misleading *in vitro* reactivity also in the case of extract-based testing or when using CCD-containing natural purified glycoproteins such as nCyn d 1, nOle e 1, nCup a 1, nSal k 1, nPla a 2 or nArt v 1.⁶²⁰ Recombinant proteins produced in *Escherichia coli* bacteria are not affected by CCD recognition, because of the lack of the

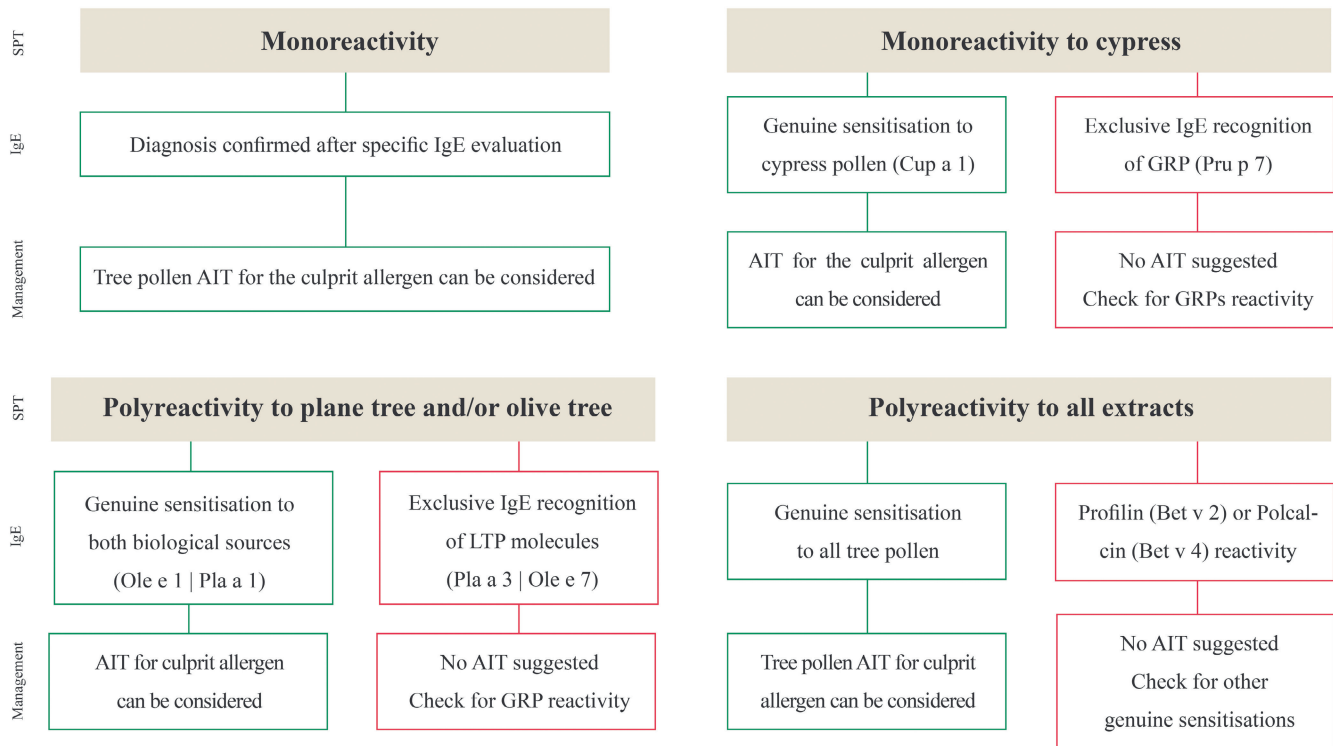


FIGURE 47 Examples of clinical decision algorithms for different setting of reactivity in SPT or IgE testing with allergen extracts.

post-translational glycosylation of proteins⁶²¹ Bromelain (Ana c 2) or the purified N-glycan from bromelain MUXF3 are available to detect CCDs *in vitro* in the vast majority of pollen sources, except for nArt v 1 where CCD reactivity is driven by O-glycans and not N-glycans measurable with bromelain or MUXF3. A positive skin prick test or *in vivo* (i.e., nasal, or conjunctival) challenge with the biological source can prove the genuine IgE recognition.⁵⁰ In (Figure 45) we suggest several algorithms possibly useful to complete the diagnostic work-up of tree pollen allergic patients.

5 – Clinical Cases

Case 1 (original):

Clinical History: Male, Italian, 10years old with seasonal rhinitis between February and June and oral allergy syndrome induced by raw fruits (apple, peach) and vegetables (carrot, celery).

IgE and skin tests: in 2016, the boy reacted to Birch, Hazel, Oak and Cypress on skin prick testing, whilst no allergy to food was detected. *In vitro* IgE measurements by extracts showed reactivity to all pollens and plant foods tested, due to strong CCD reactivity.

The component resolved diagnosis by a commercial multiplex platform revealed IgE reactivity to PR10 molecules (rApi g 1: 4,46 ISU-E; rAra h 8: 0,13 ISU-E; rBet v: 1 3,67 ISU-E; rCor a 1.0101 0,21 ISU-E; rCor a 1.0401: 2,32 ISU-E; rGly m 4: 0,52 ISU-E; rMal d 1: 0,19 ISU-E), cypress pollen allergens (nCry j 1: 2,29 ISU-E; nCup a 1: 2,24 ISU-E) and CCD markers of reactivity (MUXF3 (Ana c 2.0101): 4,13 ISU-E; nPla a 2: 3,30 ISU-E; nJug r 2: 0,94 ISU-E).

Subsequently, due to anaphylactic reactions (diffuse angioedema, respiratory distress and hypotension) following the ingestion of peach on one occasion and mandarin in a second case, the young patient was further evaluated by another multiplex platform in 2021 that revealed an IgE sensitization to peamaclein along with the already known reactivity to PR10 (rPru p 7 (Gibberellin-RP): 17,79 kU/L; rAln g 1: 3,4 kU/L; rApi g 1: 9,96 kU/L; rAra h 8: 0,38 kU/L; rBet v 1: 7,08 kU/L; rCor a 1.0103: 15,42 kU/L; rCor a 1.0401: 3,24 kU/L; rDau c 1: 8,51 kU/L; rFag s 1: 23,34 kU/L; rGly m 4: 0,63 kU/L; rMal d 1: 10,79 kU/L).

Interestingly, the latter platform, which includes the inhibition of CCD reactivity, did not show any sensitization to the native cypress or plane tree molecules (nCry j 1, Cup a 1, nPla a 2).

Conclusion: In this case, the multiple allergen recognition was associated with CCDs sensitization, and interfered with the correct assessment of the *in vitro* analysis. This patient was probably primarily sensitized to cypress due to Cup s 7 sensitization (which is currently not detectable) but certainly not due to Cup a 1 reactivity that scored positive only due to CCD recognition.

Case 2 (original):

Clinical History: Male, Italy, born 1994. Patient suffering from perennial allergic rhinitis. Because of concurrent antihistaminic therapy, the patient underwent a routine specific extract IgE evaluation.

Test with extracts: (A) *In-vitro* testing: birch: 25 kU/L; olive tree: 18 kU/L; plane tree; 14 kU/L; Cypress: 30 kU/L;

D. pteronyssinus: 44 kU/L. (B) SPT: After discontinuation of antihistaminic therapy, the patient went through a cutaneous allergic

evaluation that gave negative results for all the four tree pollen tested and mono-reactivity to *D. pteronyssinus* and *D. farinae*.

Test with molecules: ImmunoCAP ISAC: Der p 2: 35 ISU-E | Der f 2: 42 ISU-E | Lep d 2: 2.3 ISU-E; rBet v 1: Negative; nCry j 1: 1.2 ISU-E; nCup a 1: 3.3 ISU-E; nOle e 1: 2.8 ISU-E; rPla a 1: Negative; nPla a 2: 4 ISU-E; rPla a 3: Negative; MUXF3: 18 ISU-E.

Conclusion: The serology identifies the patient as genuinely sensitized only to house dust mite. The presence of MUXF3 reactivity indicates a CCD recognition further confirmed by the reactivity to native tree pollen molecules (Ole e 1, Pla a 2, Cup a 1 and Cry j 1) in the presence of negative result considering recombinant (not CCD bringing) molecules (rBet v 1, rPla a 1, rPla a 3) and in the absence of skin test reactivity to tree pollen extracts (CCD IgE reactivity is never followed by a positive skin test result).

Case 3 (original):

Clinical History: Female, Italy, born 1973. The patient has been suffering from seasonal allergic rhinitis and asthma since 2000.

After ingestion of 2 walnuts, anaphylactic reaction (abdominal pain, dyspnea, generalized flushing and swelling, low blood pressure), subsequent emergency treatment and hospitalization overnight. No food allergy to peach or other food item is known so far.

Test with extracts: (A) SPT: Environmental allergens: Pellitory (Parietaria j): 9 mm × 5 mm; plane tree (Platanus a.): 6 mm × 7 mm; olive tree (Olea e): 7 mm × 10 mm; Mugwort (Artemisia v.): 3 mm × 4 mm. Food allergens: all negative except walnut (*Juglans regia* nut): 15 mm × 10 mm (peach negative). (B)

In-vitro testing: [2014] Total IgE 49.3 kU/l, specific IgE to pellitory (Parietaria j): 2.5 kU/l; plane tree (Platanus a.): 0.56 kU/l; Olive tree (Olea e): 0.78 kU/l; Mugwort (Artemisia v.): 0.42 kU/l; Walnut 3.82 kU/l; rPru p 3: 0.76 kU/l.

Test with molecules: (ImmunoCAP ISAC): Par j 2: 1.56 ISU-E; Jug r 3: 1,15 ISU-E; Ole e 7: 9,82 ISU-E; Pla a 3: 1,98 ISU-E, (Pru p 3: negative).

Conclusion: Strict avoidance of walnut. AIT prescribed only for Pellitory.

B02 – Grass pollen allergy

Janet M. Davies, Paolo M. Matricardi, Johannes Schmid

Highlights

- IgE to group 1 allergens (e.g., Phl p 1) is a marker of true grass pollen sensitization.
- Whilst IgE to other major grass pollen allergens are rarely observed in the absence of IgE to Phl p 1, IgE to Phl p 5 or Phl p 2 can serve as markers of true grass pollen sensitization.
- A number of allergen families exist in grass pollens, but IgE reactivity to Phl p 4, Phl p 7, Phl p 11, or Phl p 12 may be due to cross-reactivity (CCD or pan-allergenicity).
- Early onset of IgE sensitization to grass pollen allergens, particularly Phl p 1, and a high number of sensitizations (Phl p 5, 7 and 12) may be prognostic markers of disease progression, but further studies are needed.
- In temperate climates, patient serum IgE shows broad cross-reactivity between similar allergen components from different temperate grass pollens.
- Group 1 allergens of subtropical grass pollens (Pas n 1, Sor h 1 and Cyn d 1) are more relevant allergens for patients in subtropical regions.

1 – The allergen sources

Grasses are found on all continents except Antarctica. In places with a temperate climate, members of the Pooideae subfamily⁶²² like Timothy grass (*Phleum pratense*), Orchard grass (*Dactylis glomerata*), Perennial ryegrass (*Lolium perenne*) and bluegrass (*Poa pratensis*) are the most common grasses. The pollen of this Pooideae subfamily show extensive IgE cross-reactivity. Grasses have a pollinating season from May to August in Central Europe, peaking in June. In Northern Europe, the grass pollen season starts later, while pollination lasts from March to July for a longer period in Mediterranean Europe (Figure 48). The grass pollen season overlaps with weed pollen (mugwort, ragweed) in most parts of Europe and with tree pollen (olive, plane) in Southern Europe. As in Europe, grass pollen seasons vary in North America, with an earlier onset and longer duration in the warmer parts, leading to different *Phleum pratense* pollen component sensitization patterns in different regions.⁶²³ In subtropical and tropical regions of the world, grass pollen seasons can be perennial, and are still the dominating pollen source flowering during spring, summer and autumn.^{624,625} Subtropical sources of allergenic grass pollens include those of the Panicoideae subfamily; Bahia grass (*Paspalum notatum*) and the prolific weed Johnson grass (*Sorghum halepense*), as well as the Chloridoideae subfamily; Bermuda grass (*Cynodon dactylon*).⁶²⁴ Timothy grass is originally native to Europe and adjacent regions in Africa and Asia. It is widely cultivated throughout

most temperate regions of the world for pasture and hay production. Despite of substantial geographical variations, grass pollen is the most prevalent sensitizing pollen in population surveys of respiratory allergies, with a median prevalence for timothy grass pollen in Europe of 16.5%⁶²⁶ and for Ryegrass pollen of 19.5% in the United States of America.⁶²⁷

2 – Major and relevant minor allergenic molecules

At present, ten allergenic molecules from Timothy grass pollen have been officially listed by the IUIS Allergen Nomenclature Sub-Committee. Phl p 2, Phl p 3, p 5 and p 6 are specific for grasses from the Pooideae subfamily whereas polcalcin (Phl p 7), profilin (Phl p 12) and oleosin related protein (Phl p 11) are related to allergens of other pollen sources (Figure 49, Table 16).

Orthologues of the group 1 beta-expansin grass pollen allergens represented by Phl p 1 of Timothy grass are ubiquitous and specific for pollen of the *Poaceae* family. Sensitization to Phl p 1 usually precedes other grass pollen sensitizations and is the most prevalent component sensitization in grass pollen allergic patients.³⁰⁹ It is a useful marker for primary grass pollen sensitization. Phl p 1 is a beta-expansin, bound to the cell wall and important for pollen tube penetration. Phl p 1 is a major grass pollen allergen, with more than 80% homology to group 1 allergens from other members of the Pooideae subfamily.⁶²⁸ Phl p 1 shares epitopes with group 1 allergens from other grasses and shows IgE cross-reactivity to most other group 1 allergens from grasses, corns and other monocots.²³⁶

Phl p 5 also is a major pollen allergen specific to temperate grasses with lower sensitization prevalence but often with high specific IgE levels. Phl p 5 is a cytoplasmatic ribonuclease, important in the enzymatic degradation of RNA. It shows broad IgE cross-reactivity with other group 5 allergens from the Pooideae subfamily of temperate grasses, but the isoforms of group 5 allergens can vary within and between species.

Phl p 6 is another major Timothy grass pollen allergen, specific for the Pooideae subfamily. Its function has not yet been described.

Phl p 4 is a tryptase-resistant glycoprotein, berberine bridge enzyme, involved in the synthesis of alkaloids. It can be classified as a major allergen.⁶²⁹ It shows IgE cross-reactivity with other group 4 grass pollen allergens, including with Cyn 4 to some extent. Moreover, cross-reactivity to the major ragweed allergen Amb a 1 and to Oilseed Rape pollen has been demonstrated. Natural Phl p 4 contains CCD, which may lead to IgE cross-reactivity with a wide range of plants and plant products

The Phl p 2 and Phl p 3 allergens are proteins with homology to the C terminal domain of the beta-expansin protein family.⁶³⁰ They show substantial similarities and are specific for the Pooideae subfamily. Their biochemical function is not yet known.

Phl p 13 is a polygalacturonase, which is a hydrolytic enzyme, degrading parts of the pectin network in plant cell walls. It is a major allergen, specific for the Pooideae subfamily.



FIGURE 48 Clinically important examples of common temperate (*Pooideae*) and subtropical (*Panicoideae* and *Chloridoideae*) grass pollen allergen sources. Species origin, geographical distribution and peak pollinating periods in common regions are included. Timing of pollination of *Pooideae* species refers to the Northern Hemisphere.

Phl p 11 belongs to the Ole e 1 related proteins and hence exhibits a broad range of cross-reactivity to pollen from different plants as olive, ash, privet, saffron crocus, thistle, plantain and corn. It is an acidic polypeptide with homology to the tryptase inhibitor of soybean.

Phl p 7 and Phl p 12 are minor allergens, representing pan-allergens from the plant world. Phl p 7, polcalcin, is a calcium-binding protein present in many different types of pollen, hence representing a broad cross-reacting allergen: birch, alder, juniper, ragweed, mugwort, olive, goosefoot etc. sensitization to Phl p 7 can be used as a marker of a wide pollen sensitization.

Phl p 12 is a member of the profilin family, an actin-binding protein that is present throughout the whole plant world. As profilins are ubiquitous in plant cells, profilin sensitization gives rise to a long range of cross-reacting plants and plant derivatives such as birch, soybean, corn, latex and plant foods.

Subtropical grass pollens of Bahia grass (*Paspalum notatum*) and Bermuda grass (*Cynodon dactylon*) show only limited IgE cross-reactivity with the pollens from the Pooideae subfamily.²³⁶ Patterns of IgE cross-reactivity between subtropical and temperate grass pollen appear to depend of the geographical region of the patient population being investigated.

Subtropical grass pollens contain the major beta expansin group 1 allergen family; Pas n 1 of Bahia grass, multiple isoforms of Sor h 1 of Johnson grass and Cyn d 1 of Bermuda grass. A number of group 1 pollen allergens have recently been described from tropical regions of Asia from other Panicoideae subtropical grasses; Para (*Urochloa mutica*)⁶³¹ and Manila grass (*Zoysia matrella*).⁶³² The polygalacturonase components Pas n 13 of Bahia and Sor h 13 of Johnson grasses, are the second most abundant protein and frequently recognized allergens from pollen of *Panicoideae* family of subtropical regions.

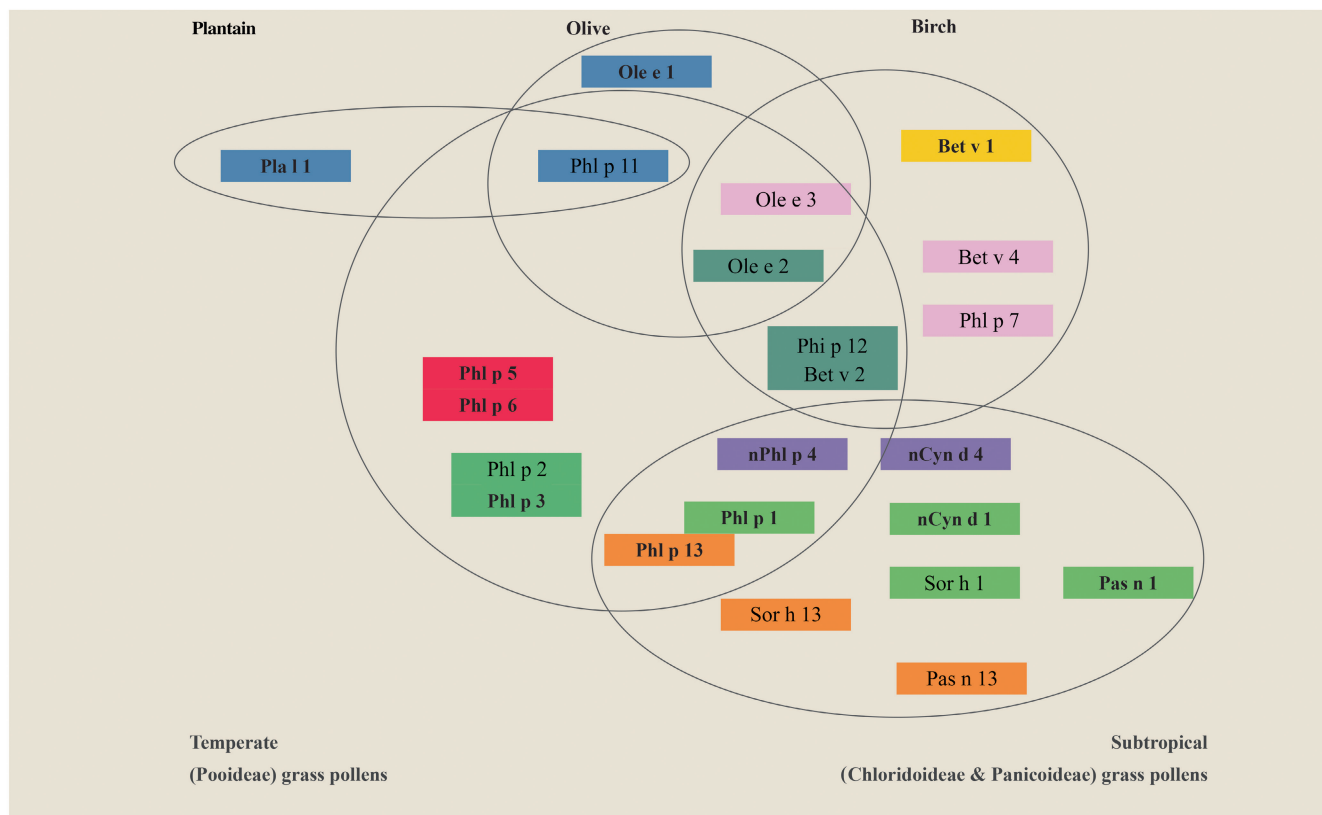


FIGURE 49 A Venn diagram showing allergens of different sources that are similar to temperate and/or subtropical grass pollen allergens. Major allergens are in bold. Allergens of the same biochemical family are shown in boxes of the same colour. Pan-allergens including profilins (dark green boxes, e.g., Phl p12) and polcalcin (pink boxes, e.g., Phl p 7) are in small font.

TABLE 16 Overview of the most relevant allergenic molecules from timothy grass and clinically relevant subtropical grasses.

Allergen group	allergenicity	Allergome code	Biochemical name	Function	MW (kDa)	Isoform
Timothy grass [1696][2][1697]						
Phl p 1	83-95 %	549-551	CCD-bearing protein	Beta-expansin	27	2
Phl p 2	55-65 %	555	Grass group 2	Unknown	10-12	1
Phl p 3	60 %	556	Grass group 3	Unknown	10-11	2
Phl p 4	70-75 %	557	CCD-bearing protein	Berberine-bridge enzyme	55	6
Phl p 5	50-95 %	558	Grass group 5	Ribonuclease	29-32	16
Phl p 6	44-75 %	569	Grass group 6	unknown	11	2
Phl p 7	7-10 %	570	Polcalcin	Calcium-binding protein	6	1
Phl p 11	32-43 %	552	Ole e 1-related protein	Trypsin inhibitor	20	1
Phl p 12	15 %	553	Profilin	Actin-binding protein	14	3
Phl p 13	50 %	554	Grass group 13	Polygalacturonase	55	1
Subtropical grasses						
Cyn d 1	76-100%	266	Glycoprotein	Beta-expansin	32	12
Cyn d 4	100%	819	Glycoprotein	Berberine bridge enzyme	60	1
Pas n 1	85-92%	874	Glycoprotein	Beta-expansin	29-30	2
Pas n 13	48%	9456	Glycoprotein	Polygalacturonase	50	4
Sor h 1	76%	643	Glycoprotein	Beta-expansin	28.4	2
Uro m 1	100% of 6 patients	12168	Glycoprotein	Beta-expansin	30	2
Zoy m 1	100% of 7 patients	No	Glycoprotein	Beta-expansin	30	1

Several allergens have been described from Bermuda grass pollen including the berberine bridge enzyme orthologue Cyn d 4 that is a major allergen. IgE reactivity with a group 2 allergen Sor h 2 of Johnson grass pollen has recently been discovered.⁶³³ Notably, however, to date no allergen with significant homology with the *Pooideae* group 5 allergen has been discovered by proteomic or transcriptomic analysis of subtropical grass pollens.

As mentioned above allergen molecules from different members of the *Pooideae* subfamily are highly IgE cross-reactive.⁶²⁹ As both wild and cultivated grasses in the temperate climate zones belong to the *Pooideae* subfamily, *Phleum pratense* allergens can be used for diagnostic and therapeutic purposes in grass pollen allergic patients living in the temperate parts of the world. However, depending on the biogeographical region and presence of different types of grasses, sensitization to pollen of different subfamilies differs across Australia which climate zones range from tropical to temperate,⁶³⁴ and there were significant differences in inhibition of sIgE to Lol p 1 (*Pooideae*), Cyn d 1 (*Chloridoideae*), and Pas n 1 (*Panicoideae*) by pollen extracts from these different subfamilies for patient originating from temperate compared with subtropical regions.

3 – Sensitization to individual molecules and their clinical relevance

The specific IgE response against grass pollen (e.g., *Phleum pratense*) usually evolves from an initial, monomolecular stage to an oligomolecular stage and eventually to a polymolecular sensitization stage.³⁰⁹ This phenomenon has been described during childhood and is defined as “molecular spreading,” that is, “The sequential development of antibody (IgE) response to distinct non-cross-reacting molecules from the same antigenic (allergenic) source, starting with an “initiator” (allergenic) molecule.”⁹⁵ (Figure 50). Phl p 1 is the probable “initiator” molecule in most patients with (temperate) grass pollen allergy, and the response involves then Phl p 4 or Phl p 5,

thereafter also Phl p 2 and Phl p 11 and at a later stage Phl p 12 or Phl p 7. This has been confirmed in other birth cohort studies.³¹¹ The pathophysiological consequence of this phenomenon is that the longer is the duration of disease, the broader is the repertoire of IgE sensitization against the different molecules of the pollen source.⁶³⁵

This has led to the consideration that AIT could be started earlier in a patient's clinical care, possibly even immediately after the first season in which the allergic respiratory symptoms are initiated (“early-AIT”).⁹⁵ However, the molecular spreading process follows different pathways in different children: some patients remain sensitized only to the “initiator” molecule while a few patients become sensitized to most or all allergenic molecules. Consequently, a population of grass-pollen allergic patients “apparently” homogeneous if tested with an allergen extract reveals remarkably heterogeneous when examined with the corresponding molecules.^{82,311} clinical relevance of the individual profile of sensitization is being tested in large populations both in cross-sectional, observational studies (Dramburg S. et al., in preparation) and in longitudinal intervention studies (Potapova et al. submitted). However, only few data have yet been published; in a recent study a higher risk of asthma at 11 years was observed in children being sensitized at 5 years to almost all grass pollen allergen molecules in comparison with those who had a late onset of sensitization.^{311,635}

IgE to Phl p 1 - Clinical relevance – Phl p 1 (or another one of the “group 1” antigens of grass pollen, such as Lol p 1, from *Lolium perenne*) is the “initiator” molecule in most patients. Moreover, even in the few grass-pollen allergic patients who start their sensitization process with other molecules, IgE against Phl p 1 is produced soon thereafter. Consequently, IgE sensitization to Phl p 1 is an essential marker to establish “true sensitization” in grass pollen allergic patients. The presence of IgE to Phl p 1 confirms that the patient with a positive Skin Prick Test or serum IgE assay to extract is truly sensitized to grass pollen. The absence of IgE to Phl p 1 does not exclude “true” sensitization to grass pollen, which might be due (in a few cases) to isolated IgE sensitization to other major allergenic proteins (e.g., Phl p 5) but makes it rather unlikely. Then patients with skin prick test-IgE positivity to a

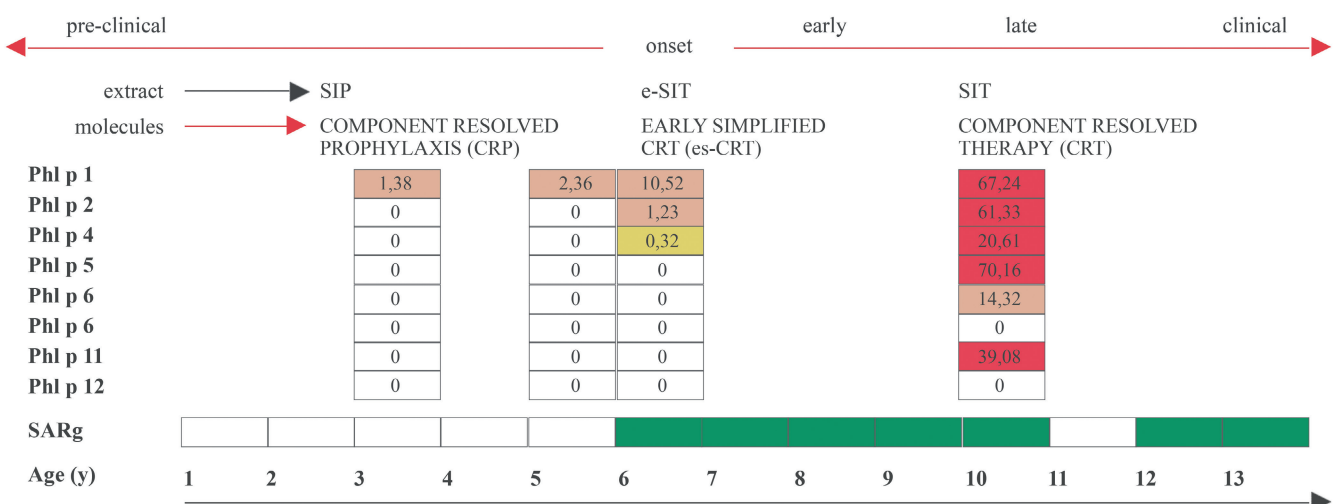


FIGURE 50 The molecular spreading of the IgE response to Timothy grass and possible implications for AIT intervention.

grass pollen extract but lacking specific IgE to Phl p 1 should be tested for IgE to other Phl p molecules. The group 1 allergens are the major and clinically most important allergen of subtropical Panicoideae grass pollens. Whilst other allergen components are present in subtropical grass pollens, specific IgE to Pas n 1 of Bahia grass pollens accounts for nearly all of the detectable IgE reactivity to the whole extract.⁶³⁶ Similarly, specific IgE reactivity to Sor h 1 of Johnson grass pollen is highly correlated with IgE reactivity with the whole pollen.⁶³³ For Bermuda grass pollen, Cyn d 1 is the major allergen, but the complexity of described allergen components is broad.⁶²⁴

IgE to Phl p 5 - Clinical relevance – Phl p 5 is rarely the only molecule inducing grass pollen sensitization and the presence of specific IgE to Phl p 5—observed in around 50%–95.5% of the European grass pollen allergic patients—confirms that a positive SPT reaction is the expression of true sensitization to grass pollen. However, although IgE to Phl p 5 usually appears later than that to Phl p 1 in the sensitization process, its concentration grows rapidly in many patients and higher and its contribution to patients' symptoms has been demonstrated.⁶³⁷ Testing IgE to Phl p 5 can be useful as a second line test and has been shown to be useful for distinguishing between allergy to grass and olive pollen in Southern Europe. Specific IgE to Phl p 5 may have some prognostic value for indicating disease severity or likely progression from allergic rhinitis to asthma, but this needs to be confirmed with well-designed studies. As group 5 allergens have not been found in subtropical grass pollens, specific IgE to Phl p 5 may particularly indicate sensitization to temperate grass pollens. This needs to be investigated in relevant patient populations.

IgE to Phl p 12 - Clinical relevance (see also Chapter C01) – Phl p 12, is the highly cross-reactive profilin of *Phleum pratense*. As a heat-labile, relatively weak allergenic molecule, specific IgE sensitization to profilin comes later in the molecular spreading process, reaches only moderate levels of IgE antibodies and only in a minority of patients. Hence, IgE to Phl p 12 mark in general those patients with a higher atopic background and/or longer disease duration. Patients with a positive skin prick test/serum IgE to grass pollen extract but no detectable IgE to Phl p 1 and/or Phl p 5 must be tested for IgE reactivity to Phl p 12 as these antibodies—that can be induced by other pollens containing profilin—is the first cause of “false” positivity to assays based on grass pollen extract. In the presence of specific IgE to Phl p 12, patients should be asked about Oral Allergic Syndrome triggered by the ingestion of fruits and vegetables containing profilin.

Tips for the use of molecular diagnostics for grass pollen allergy

- IgE to Phl p 1 is a marker of “true sensitization” to grass pollen
- Exceptions: In a few rare cases with skin test positivity to a grass pollen extract but no detectable IgE to Phl p1, IgE to Phl p5, may confirm the diagnosis of grass pollen allergy.

IgE to Phl p 7 - Clinical relevance (see also Chapter C06) – Phl p 7, is the highly cross-reactive polcalcin of *Phleum pratense*. This is a heat-stable, relatively potent allergen that can induce quite high specific IgE antibody levels. An IgE response to Phl p 7 is observed only infrequently among grass pollen allergic patients and usually many years after disease onset. Specific IgE to Phl p 7 indicates a relatively distinct category of grass pollen allergic patients, with more severe symptoms, a higher prevalence of asthma, and a higher frequency of allergic comorbidities.⁶³⁸ Moreover, many other pollens and allergenic sources contain polcalcin so that the original sensitization to polcalcin in a grass-pollen allergic patient must be carefully searched.^{638,639} These other allergenic sources could be indeed responsible for a more severe disease.

IgE to Phl p 4 - Clinical relevance (see also Chapter A03) – Phl p 4 is a major allergenic protein of grass pollen. In its native form, that is still used in most commercial available assays, Phl p 4 contains extremely highly cross-reactive carbohydrate determinants (CCD). This explains why in several epidemiological studies IgE positivity to Phl p 4 scores over 90% of the grass pollen allergic patients. However, when the recombinant form of the molecule is used in assays, about 50% of that positivity is not confirmed any more.^{639,640} (Matricardi PM, data on file). As extracts contain the native Phl p 4, a weak positivity to SPT/serum IgE test based on grass pollen extracts can be “false” in some patients and simply explained by IgE recognition of CCD determinants. Phl p 4 may also serve as a marker of sensitization to Bermuda grass pollen due to its similarity with Cyn d 4, a major allergen of Bermuda grass pollen, but this needs to be investigated in relevant patient populations. Recently, sIgE to Phl p 4 as well as Phl p 1 and Phl p 5 have been identified as an early indicator of allergic rhinitis in 763 children from Sweden.⁶⁴⁰

IgE to Phl p 2, 6, 11 – Phl p 2 and Phl p 11 are both rarely the only molecule inducing grass pollen sensitization and the presence of IgE antibodies to Phl p 2—observed in around 60–80% of the European grass pollen allergic patients—just confirms that a positive SPT reaction is the expression of true sensitization to grass. Phl p 6 is highly cross-reacting with Phl p 5 and does not add a lot of diagnostic information, once IgE to Phl p 5 has been documented.

4 – Predictive Value of Specific IgE responses to Allergenic Molecules

IgE to grass pollen molecules as biomarkers of disease – The presence of allergen-specific IgE towards airborne allergen molecules has been investigated as a putative predictive biomarker for the development of asthma throughout childhood and adolescence. In the case of seasonal allergic rhinitis to timothy grass pollen, individual risk profiles the predictive power of IgE sensitization to certain marker molecules, such as the profilin grass pollen allergen Phl p 12, which correlates with an increased risk for the development of an Oral Allergy Syndrome (OAS), has been confirmed in a cohort of over 1000 grass pollen allergic Italian children.⁸⁵ Similarly, the same study confirmed a strong association between IgE sensitization to Phl p 7 (polcalcin) and asthma. A molecular combinatorial analysis

confirmed that the qualitative homogeneity of IgE sensitization to the extract of *Phleum pratense* among grass pollen-allergic patients is only apparent. The number of described grass pollen IgE sensitization profiles, originally limited was expanded to 87, suggesting that, theoretically, all the 256 possible combinations could be observed in the general population of patients allergic to timothy grass pollen, limiting potential prognostic value. However, some IgE sensitization profiles were much more frequent than others, so that their hypothetical clinical relevance could be investigated. Thus far, no association between any of those frequent specific profiles of IgE sensitization to the eight most relevant allergenic molecules of *Phleum pratense* pollen, with the clinical phenotype of allergic rhinitis and conjunctivitis could yet be identified.⁶³⁸ In other words, the study excluded that a combinatorial analysis of the spectrum of molecular IgE sensitization to Timothy grass pollen is of any diagnostic relevance, probably for the highly multifactorial origin of allergic rhinitis in this cohort was enriched in highly polysensitized children.⁶³⁸ Whether or not the characterization of the IgE sensitization profile to the full set of eight Phl p molecules could be more relevant in patients sensitized only to grass pollen remains an open research question. Interestingly, a 6-year long prospective study of 401 patients of the same cohort highlighted that the observation of IgE to Phl p 1 is relevant for persistence of seasonal allergic rhinitis; IgE to Phl p 5 is predicting persistence of both rhinitis and asthma,⁶³⁸ which may have clinical value if confirmed in other populations.

Ryegrass pollen and components as markers for thunderstorm asthma risk – In other parts of the world, including temperate regions of Australia, where timothy grass is rare and ryegrass (*Lolium perenne*) is common, sensitization to ryegrass pollen, and more specifically Lol p 5 or ryegrass pollen starch granules, containing Lol p 5, have been associated with patients presenting with asthma in the context of thunderstorm asthma epidemics.⁶⁴¹ Southeastern Australia and, in particular, Melbourne, has experienced the highest number of thunderstorm asthma events and the highest number of patients affected globally, making understanding and controlling acute thunderstorm asthma risk an imperative.⁶⁴² Positive skin prick test to ryegrass pollen occurs at increased frequency and magnitude in thunderstorm asthma cases vs. controls presenting with asthma at other times.^{643,644} Circumstantial evidence also indicates that during thunderstorm asthma events, ruptured grass pollen does occur.^{644,645} Whilst there is high similarity between the major allergens of timothy grass and ryegrass pollen, the amino acid composition differs between isoforms of Phl p 5 of Lol p 5, and it may be relevant, that sIgE to major ryegrass pollen serve as prognostic biomarkers of seasonal allergic asthma risk including thunderstorm asthma risk, in patients with allergic rhinitis in temperate regions of Australia.⁶⁴⁶

5 – Specific IgE responses to allergenic molecules and response to allergen immunotherapy

Nasal IgG4 to Phl p 1 & Phl p 5 and SCIT efficacy – Encouraging and very interesting information emerged from a trial discovering

that IgG4 to *Phleum pratense* molecules in the nasal secretions are biomarkers of efficacy of allergen immunotherapy in grass pollen allergic patients.⁶⁴⁷ In this trial, the levels of nasal IgG4 to Phl p 1 and to Phl p 5 were increased during the pollen season compared with out of season among the patients treated with SCIT compared to those untreated. IgG-associated inhibitory activity in nasal fluid and serum was significantly increased in the SCIT group compared with the untreated group. Inhibitory activity associated to IgG4 antibodies to Phl p 1 and Phl p 5 correlated therefore closely with the clinical response to allergen immunotherapy in patients with allergic rhinitis with or without asthma. Nasal secretions might become therefore a valuable alternative for *in vitro* tests searching antibodies against allergen molecules in patients with respiratory allergies.⁶⁴⁸ However, recent studies on nasal IgE showed that the concentration of sIgE is much lower in nasal secretions than in the serum. Consequently, sIgE assays with very high analytical sensitivity and sampling methods with minimal dilution are needed before nasal secretions can be validated as alternative to serum in testing the sIgE repertoire in patients with seasonal allergic rhinitis.⁶⁴⁹

Pre-SCIT I IgE sensitization pattern predicts IgG4 response to SCIT – In a study of 18 grass pollen allergic patients treated with SCIT, the pretreatment IgE repertoire to the different grass pollen components predicted the repertoire of the induced IgG4 antibodies after completing up dosing. This may indicate, that sIgE to specific components is a prerequisite for the induction of competing IgG4 antibodies during SCIT.⁶⁵⁰ At the same time, this study did not find induction of new sensitizations to grass pollen components, the study subjects had not been sensitized to before starting SCIT.

BM32 hybrid molecule – A single recombinant hybrid molecule, consisting of the four major Timothy grass pollen allergens (Phl p 1, Phl p 2, Phl p 5, and Phl p 6) was suitable for *in vivo* diagnosis of genuine grass pollen allergy in children suffering from pollinosis in Greece.²⁸² With this hybrid molecule, genuine grass pollen sensitization was confirmed through SPT in 94% of the children with positive SPT to grass pollen extract by SPT and IgE reactivity to the hybrid. Only 4 hybrid-negative children showed IgE reactivity to SPT with grass pollen extract, but they were confirmed to react against cross-reactive allergens such as Phl p 4, Phl p 11, and Phl p 12 and had also sensitizations to pollen allergens from unrelated plants. This study demonstrated therefore that a recombinant hybrid molecule approach represents a useful tool for *in vivo* diagnosis of genuine grass pollen sensitization and opened a new avenue to the use of bioengineered molecules in *in vivo* diagnostics of allergic diseases in general.

In patients allergic to grass pollens specific IgE testing to allergen molecules should be oriented to answer the following questions:

- A. Is the patient really sensitized to grass pollen major allergen molecules? (test Phl p 1, if negative also Phl p 5 and the other molecules);
- B. Is the patient sensitized also to highly cross-reacting molecules? (test Phl p 12 and Phl p 7);

C. In case of negativity to Phl p 1 and the other species-specific allergenic molecules and positivity to Phl p 12 and/or Phl p 7, which pollen is inducing a “false” IgE sensitization to grass pollen extracts?

After having answered these questions the doctor should be able to decide whether the patients' symptoms are consistent or not to IgE sensitization to grass-pollen, and consequently can decide whether to prescribe an AIT based on grass-pollen extract. Whilst orthologues such as Cyn d 7 and Sor h 12 have been reported in subtropical grasses, there is currently limited evidence available of IgE reactivity in relevant patients primarily sensitized to subtropical grass pollens. A diagnostic algorithm for a decision making process, which summarizes the information provided in the previous section is proposed (Figure 51).

Clinically Relevant

- The major allergen Phl p 1 serves as a specific diagnostic marker for grass pollen allergy in temperate regions. Phl p 5 and Phl p 2 may serve as secondary diagnostic or prognostic markers for some patients. Exceptions: In rare cases a grass pollen allergic patient can lack IgE to Phl p 1.
- Whilst minor pan-allergens Phl p 12 and Phl p 7 may not increase diagnostic specificity, in some geographical regions Phl p 12 IgE appears to be associated with true grass pollen allergy.

6 – Clinical cases

Case 1

Clinical history: A 35 year old male from Central Italy patient presented with allergic rhinitis from April to July but not in September or October. The patient had experienced conjunctival and nasal symptoms that did not respond to antihistamines and were only partly controlled with nasal steroids. He reported the condition was steadily increasing each season and that he, occasionally, experienced a tight chest after spending time outside. Since the last year, he had experienced oral symptoms (pruritus, swelling) after eating either melon or watermelon.

Testing: SPT positive for birch (5 mm), Timothy grass (8 mm), pellitory (4 mm), olive (3 mm) pollens. Serum IgE antibody levels were 7.1 kU/L to birch, 17.3 kU/L to timothy grass, 6.7 kU/l to pellitory, 3.2 kU/l to olive extracts.

Treatment: No AIT was started as the doctor was not sure which pollen(s) was/were responsible of the patient's symptoms.

Added CRD value: positive response to Phl p 1 (12.2 kU/l), Phl p 5 (6.5 kU/l), and Phl p 12 (4.3 kU/l) but not to Bet v 1, Ole e 1, and Par j 2. The patient commenced SLIT with grass pollen and responded well to this treatment. OAS was also explained by IgE sensitization to profilin (Phl p 12).

Case 2

Clinical history: A 26 year old Danish woman with a 10 year history of persistent severe seasonal rhinoconjunctivitis during birch and grass pollen season. Symptoms most severe in early summer, with persistent conjunctival (redness, itching, watering, light sensitivity) and nasal (blocked nose, itching and secretion) symptoms. Very poor response to systemic antihistamines and topical antihistamine

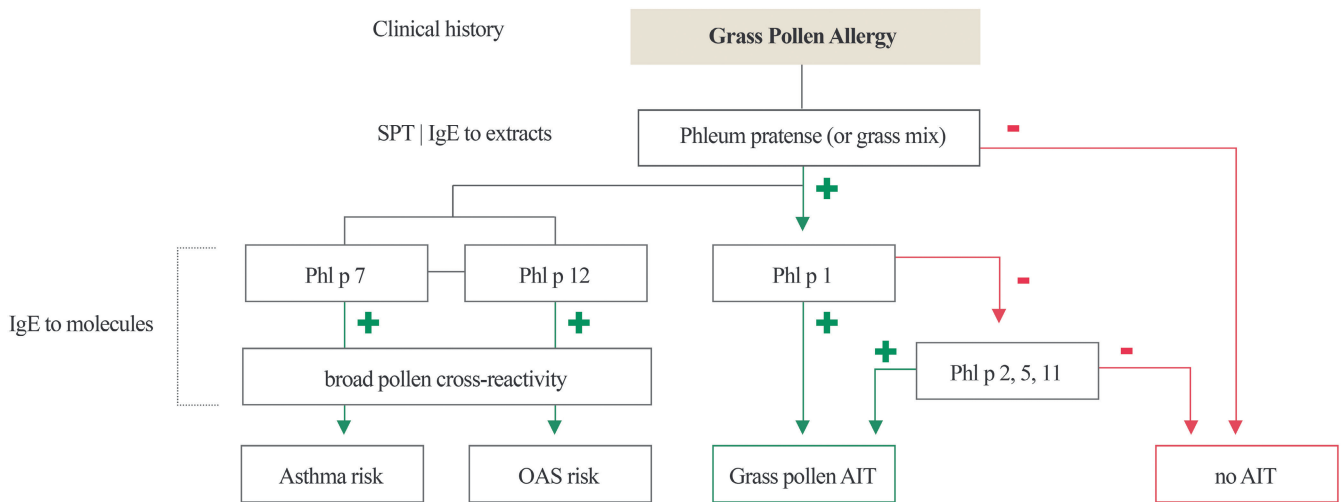


FIGURE 51 Diagnostic algorithm for AIT prescription in grass pollen allergic patients—Patients with AR symptoms during the grass pollen-season and a positive SPT/IgE assay to grass pollen extracts are further investigated to detect serum IgE antibodies to Phl p 1, Phl p 2, Phl p 5, Phl p 7, Phl p 11, and Phl p 12. The identification of one or more of IgE antibodies to Phl p 1, Phl p 2, Phl p 5 and/or Phl p 11 is followed by the prescription of grass pollen AIT. The identification of IgE to Phl p 12 (profilin) is followed by further investigation of OAS and influences is relevant to better interpret results of SPT/IgE assays with other pollen extracts or vegetables. The identification of IgE to Phl p 7 alerts the doctor of a worse prognosis and greater severity of the disease.

(eyes and nose) and to intranasal corticosteroid. Had some benefit from systemic corticosteroid. Good symptom control during birch pollen season.

Testing: SPT positive for birch and grass pollen 7 mm diameter. IgE to grass pollen 10.9 kU/l, birch pollen 3.9 kU/l

Treatment: Starts standard SCIT with natural grass pollen extract'. Poor clinical effect after 2 years of treatment. Added CRD

value = Missing Step 2b - *In vitro* testing: We found a sensitizations to Phl p 4 in the grass pollen panel, as well as Bet v 1. She was not sensitized to typical other CCD reactive natural molecules. The conclusion was that she truly was grass pollen allergic, and she received anti-IgE treatment during grass pollen season with good clinical outcome.

B03 – Weed pollen allergy

Michael Hauser, Janet M. Davies, Thomas Hawranek, Gabriele Gadermaier

Highlights

- Common invasive weeds like ragweed, mugwort and plantain, are important allergen sources typically flowering in summer through to autumn.
- The biogeographical range and pollination periods of allergenic weeds can overlap confounding accurate allergy diagnosis.
- Specific IgE to Amb a 1 can be a useful marker for ragweed sensitization, but it shows cross-reactivity with Art v 6 from mugwort and Hel a 6 from sunflower. Likewise specific IgE to Art v 1 can be a useful marker for mugwort sensitization, but it shows partial cross-reactivity with ragweed Amb a 4.
- Art v 3 reactivity plays a major role in LTP-related allergies in patients from the Mediterranean region and Northern China.
- Par j 2 is a highly specific marker for pellitory sensitization while Pla I 1 is a useful marker for genuine plantain sensitization.

1 – The allergen sources

The term “weed” does not constitute a botanical family but rather refers to diverse plants used as culinary herbs, medicinal plants that are ecologically adaptive, as well as invasive segetal plants. Pollen of weeds mediating IgE-related allergic reactions are found in the dicots of the Asteraceae, Urticaceae, Plantaginaceae, Euphorbiaceae, and Amaranthaceae plant families.⁶⁵¹ Pollen of ragweed, mugwort, sunflower, feverfew, pellitory, English plantain, Annual mercury, goosefoot, Russian thistle and amaranth are considered main weed pollen allergy eliciting sources (Figure 52). Allergenic monocot weeds of the family Poaceae (e.g., Johnson grass) can be found in Chapter B02.

The impact of climate change on pollen load, allergenicity, distribution, and flowering season is well acknowledged and is of particular interest in regard to weeds since they can dominate groundcover, adapt to various environmental conditions or reside in ecologic niches.^{651,653,654,830} Due to globalization, neophytes such as ragweed have been imported to Europe as ballast grain, spreading readily with predictions to reach Northern Europe.⁶⁵¹ Furthermore, significant increases in duration of pollen seasons of ragweed and pellitory were recorded during the last decades.^{655,656,1650} Additional influence on the allergenicity might arise from environmental pollution, as was shown for ragweed pollen collected along high-traffic roads presenting elevated IgE reactivity.⁶⁵⁷ Weeds are often considered undesired invasive species and thus combated using herbicides. On the other hand, there are some species actively cultivated for economic purposes, e.g., sunflower or *Artemisia annua* to obtain the anti-malaria drug artemisinin.

Plants of the genus *Ambrosia* comprise around 50 species native to Northern and Central America. In the past decades, the neophyte

is rapidly spreading in Europe due to the pollen's ability to travel long distances. The genus *Artemisia* comprises around 350 species and representatives can be found throughout the Northern hemisphere and Australia. Mugwort is frequently used as herb in traditional Chinese medicine and *A. annua* is cultivated for harvest of artemisinin. There are parts of Europe and America where the range and pollination of mugwort and ragweed overlap (www.discoverlife.org; Atlas of living Australia and US Department of Agriculture), confounding accurate allergy diagnosis. Common sunflower is primarily grown for commercial use of its oil and birdseed. *Parthenium spp* are found in Southern US, Central and South America and invasive in India, Australia and parts of Africa. Allergenic members of the *Parietaria* genus are frequently found in Southern and Central Europe showing a long pollination season with recurrent flowering periods. The genus *Plantago* includes around 250 species and was spreading from Europe throughout the world. *Mercurialis annua* is a highly prevalent weed throughout Europe. *Chenopodium album*, *Salsola kali* and *Amaranthus retroflexus* can be found in arid regions of the Northern hemisphere and Australia. Due to use in greening programs or as ornamental flowers, these weeds are highly abundant in Iran, Kuwait, or Saudi Arabia as well as the South East of Spain.

2 – The allergen families

The most relevant weed pollen allergens belong to the families of pectate lyases, defensin-like proteins, nonspecific lipid transfer proteins (nsLTP) and Ole e 1-like proteins (Table 17). Additionally, the pan-allergens profilin and polcalcin have been identified as cross-reactive molecules present in weed pollen (see Chapters C01 and C04). Currently, 70 weed pollen allergens are listed as allergens by the WHO/IUIS Allergen Nomenclature Sub-Committee. Recent additions of relevant allergens include homologues of defensin-like proteins (feverfew and *Artemisia spp.*), nsLTPs (*Artemisia spp.*) and a pectate lyase (sunflower). The acidic glycoprotein at 60 kDa in *Artemisia* was identified as galactose oxidase Art an 7.⁶⁵⁵ Furthermore, two new allergens belonging to the cysteine protease and enolase family were identified in ragweed pollen (Table 17).^{658a}

3 – Allergenic molecules

Ambrosia spp are major elicitors of type I pollen allergies in Northern America with a sensitization frequency in the general adult population of 15.3% in Canada and 8.7-26% in U.S.^{626,658b} In Europe, SPT positivity among allergic patients was determined to be in average lower (2.6%) but can be very high in distinct regions, e.g., Hungary 53.8%.^{658c} In Germany, sensitization to ragweed in the general population is 10%, in allergic patients it ranges between 19.5 and 36.3%.^{659a,659b} Notably, ragweed sensitization in Europe is estimated to double within the next decades due to progressive spreading of the invasive plant, fuelled by the impact of climatic changes.⁶⁵⁴ Korean children suffering from allergic rhinitis



FIGURE 52 Important allergenic weeds. Figure adapted from “Marker allergens of weed pollen”⁶⁵². Flowering periods given refer to the Northern Hemisphere.

showed a sensitization prevalence of 0.2-3.6%. Among close to 20,000 requested specific IgE tests in Japan, 17% of adults and 18.1% of children showed positive results for ragweed pollen, and in some regions of Japan 26.1% of adults and 24.9% of children

were sensitized.⁶⁶⁰ In eastern parts of Australia, sensitization frequencies ranging from 34-38% were observed among allergic patients.⁶⁶¹ Ragweed allergy is mainly driven by the major allergen Amb a 1, a pectate lyase with high sensitization prevalence and

TABLE 17 Clinically relevant weeds

Allergenic molecule	Protein family	Frequency of IgE reactivity	MW (kDa)
<i>Ambrosia artemisiifolia</i> (ragweed), <i>Ambrosia</i> spp			
Amb a 1	Pectate lyase	>95%	38
Amb a 4	Defensin-like protein with polyproline rich region	20-40%	13-15
Amb a 6	Non-specific lipid transfer protein	20%	10
Amb a 8	Profilin	35-50%	14
Amb a 9	Polcalcin (2 EF-hand calcium binding protein)	10-15%	9
Amb a 10	Polcalcin (3 EF-hand calcium binding protein)	10-15%	17
Amb a 11	Cysteine protease	66%	37
Amb a 12	Enolase	66%	48
<i>Artemisia vulgaris</i> (mugwort), <i>Artemisia</i> spp			
Art v 1*	Defensin-like protein with polyproline rich region	95%	13-15
Art v 3*	Non-specific lipid transfer protein	22-70%	10
Art v 4	Profilin	35%	14
Art v 5	Polcalcin (2 EF-hand calcium binding protein)	10-28%	10
Art v 6	Pectate lyase, Amb a 1-homologue	26%	38
Art an 7	Galactose oxidase	16-94%	62
<i>Helianthus annuus</i> (sunflower)			
Hel a 1	Potential defensin-like protein with polyproline rich region	65%	34
Hel a 2	Profilin	31%	14
Hel a 6	Pectate lyase	36%	42
<i>Parthenium hysterophorus</i> (feverfew)			
Par h 1	Defensin-like protein with polyproline rich region	40-60%	12
<i>Parietaria judaica</i> (pellitory)			
Par j 1	Non-specific lipid transfer protein	95%	15
Par j 2	Non-specific lipid transfer protein	80%	11
Par j 3	Profilin	nd	14
Par j 4	Polcalcin (2 EF-hand calcium binding protein)	6%	9
<i>Plantago lanceolata</i> (English plantain)			
Pla l 1	Ole e 1-like protein	86%	18
Pla l 2	Profilin	86%	15
<i>Mercurialis annua</i> (pellitory)			
Mer a 1	Profilin	50-60%	14
<i>Chenopodium album</i> (goosefoot)			
Che a 1	Ole e 1-like protein	70%	18
Che a 2	Profilin	55%	14
Che a 3	Polcalcin (2 EF-hand calcium binding protein)	46%	10
<i>Salsola kali</i> (Russian thistle)			
Sal k 1	Pectin methylesterase family	65%	38
Sal k 3	Cobalamin independent methionine synthase	63%	85 (35+45)
Sal k 4	Profilin	46%	14
Sal k 5	Ole e 1-like protein	30-60%	18
Sal k 6	Polygalacturonase	32%	47
Sal k 7	Polcalcin	40%	9
<i>Amaranthus retroflexus</i> (amaranth)			
Ama r 1	Ole e 1-like protein	38%	18
Ama r 2	Profilin	25%	14

Data on sensitization frequency according to Gadermaier et al.⁶⁸⁰ and the WHO/IUIS allergen nomenclature database. nd not determined.

*Besides Art v 1 and Art v 3, several recently identified homologs from *Artemisia* spp of the defensin-like and nsLTP family are listed in the WHO/IUIS database (<https://www.allergen.org>).⁶⁸⁰

allergenic potency. The cysteine protease Amb a 11 is also classified as a major allergen⁶⁶²; however, sensitization studies in larger cohorts remain to be conducted.

Artemisia spp contains more than 350 species that seem to be highly similar in their allergen profile, and IgE reactivity. *Artemisia* is considered one of the most relevant allergenic pollen source in Asia with a sensitization prevalence of 11% and 14.5% in allergic adults and children from China, respectively. In the same areas, reactivity to ragweed is only 6.5 – 8.7%.^{663,1713} Among weed allergics in Northern China, high and correlating IgE reactivity to *Artemisia* (58.3%) and Art v 1 (49%) was found. By contrast, specific IgE to *Ambrosia* (14.7%) and Amb a 1 (11.2%) was lower in frequency and level, not correlated with each other, and uncommon in the absence of specific IgE to Art v 1 suggesting primary sensitization with *Artemisia* species.⁶⁶⁴ Among Korean children with allergic rhinitis, sensitization to mugwort ranges from 2.4–11.7%, depending on the geographic region.⁶⁶⁵ In Japan, 16.1% of adults and 14.1% of children tested showed specific IgE to mugwort pollen; sensitization reached up to 25.4% for adults and 19.9% for children in some areas⁶⁶⁰. Among allergic patients, 26.1 – 27.4% tested positive for mugwort in Germany, while a cross-sectional study among Austrian adolescents revealed a sensitization frequency of 7.2% to the major allergen Art v 1.^{659,666} In the Canary islands, *Artemisia*, as determined by Art v 1 sensitization dominates pollen allergy, associated to the endemic species *Artemisia thuscula* and strong trade winds. Up to 40% of pollen allergic patients are mono-sensitized to *Artemisia*.⁶⁶⁷ Both, Art v 1 and the nsLTP Art v 3 present homologous allergens with high similarity and IgE cross-reactivity in the numerous *Artemisia* species, with sensitization frequencies of 84% and 66%, respectively, among Chinese mugwort allergic patients.^{668,669} In Northern China, Art v 3 sensitization in mugwort pollen allergic patients is high and in many cases responsible for Pru p 3-related peach allergy.⁶⁶⁹ In addition, the galactose oxidase Art a 7 seems to be a relevant allergen as it was recognized by 87% of *Artemisia*-sensitized patients from China.⁶⁷⁰

Sensitization to *Helianthus* pollen is reported with 23.5% among Turkish sunflower processing workers and 21% among pollen allergic patients from India.^{671,672} No sequence was so far assigned to the major allergen Hel a 1; however, a highly cross-reactive allergen was detected using Art v 1-specific antibodies.⁶⁷³ Recently, Hel a 6, a pectate lyase from sunflower pollen, was identified showing 57% sensitization prevalence among sunflower pollen allergic patients.³⁵⁶ Positive SPT reactivity to *Parthenium* was noted for 35% of fall pollinosis patients in the U.S. and 35.7% of type IV allergy in atopic dermatitis patients in India.⁶⁷⁴ The recently identified defensin-like allergen Par h 1 was recognized by 60% of Austrian Asteraceae and 40% of Indian feverfew sensitized patients. In addition, other allergenic proteins, e.g., a pectate lyase and pan-allergens were identified in feverfew pollen.⁶⁷⁵

Parietaria pollen is one of the most relevant causes of pollen allergy in the Mediterranean region, with an average sensitization prevalence of 46.5% and 58.9% in elderly and adolescent allergics in southern Italy, respectively.^{676,677} The major contributors to *Parietaria* allergy are the nsLTPs Par j 1 and Par j 2, which demonstrate no cross-reactivity with nsLTPs from other sources. Although

the weed is highly prevalent throughout Europe, sensitization in the non-Mediterranean population is marginal.⁵⁶⁹

A high sensitization prevalence to *Plantago* was shown in allergics of distinct regions of northern Spain⁵⁶⁹ and in South Australia where 37% SPT positivity is reported (Dr. Frank Kett, personal communication). Recent studies in Central/Northern Europe showed that among German allergic patients sensitization increased from 26.6% to 50.5% within 20 years.⁶⁵⁹ In the general adolescent population in Austria, sensitization to the genuine and major allergen Pla I 1 was as high as 10.4%.⁶⁶⁶ While an association with grass pollen or pan-allergen sensitization is frequently observed, genuine Pla I 1-related plantain allergy represents a true co-sensitization.^{358,678,679}

High levels of reactivity to *Mercurialis annua* pollen ranging from 28–56% were observed in several areas of Spain.⁶⁸⁰

Due to use of *Chenopodium album* in greening programs, the weed gained relevance in countries with desert and semi-desert areas accounting for up to 70.7% sensitization in asthmatic patients. Clinical incidences have been reported in southern Spain and Saudi Arabia, while they even represent the main sensitizer for allergic rhinitis and asthma in Kuwait and Iran. The ornamental plant *Amaranthus retroflexus* is also described as a major trigger of allergic reactions in Iran, with a sensitization frequency of 69% among allergic patients.⁶⁸¹ So far, two allergens have been identified and designated Ama r 1 (Ole e 1-like protein) and Ama r 2 (profilin).^{585,1714} *Salsola kali* allergy, as determined by specific sensitization to Sal k 1, the major *Salsola* allergen absent in Chenopodiaceae species, is overall the third cause of pollinosis in Spain and a dominant pollen allergen in the

South East region.⁶⁶⁷ In some of the drier areas of the south, up to 80% of the patients suffering from seasonal allergy are sensitized to Sal k 1, and are frequently mono-sensitized. In other areas such as the Ebro river valley it is the second cause of pollinosis after grasses.^{585,667} This allergy is also very prevalent in other dry areas like Iran where up to 72.5% of pollen allergic patients are sensitized to *Salsola*.^{680,681} Additional *S. kali* allergens have been identified and characterized in detail with IgE frequencies ranging from 30 to 60%.^{682–685}

4 – Sensitization to individual molecules and their clinical relevance

Exposure to weed pollen and primary sensitization to relevant allergens predominantly leads to rhinoconjunctivitis and/or asthma. Occupational allergies, i.e., to sunflower pollen are observed in workers and citizens in close vicinity. Sensitization to weed pollen allergens can show complex profiles including genuine, specific allergens (e.g., Pla I 1), as well as (partially) cross-reactive allergens from weeds and/or pan-allergens (Table 17). Frequent IgE cross-reactivity is observed within allergenic pollen of the Asteraceae and Amaranthaceae plant family.^{680,686} The level and clinical consequence depends on the identity of underlying allergenic molecules while it is to a certain degree patient-specific.

Amb a 1 from ragweed pollen represents a dominant, major allergen with moderate IgE cross-reactivity to the minor allergen Art v 6

from mugwort.⁶⁸⁷ Recently, Hel a 6 from sunflower was identified as a major allergen³⁵⁶ and cross-reactivity with ragweed and mugwort pectate lyases was demonstrated (Figure 53A).

The major mugwort pollen allergen Art v 1 shows different degrees of cross-reactivity with Amb a 4 and Par h 1 from ragweed and *Parthenium* pollen, respectively.⁶⁸⁸ Based on sequence similarity, cross-reactivity with SF18 from sunflower is anticipated. IgE cross-reactivity was demonstrated for the novel defensin-like allergen Api g 7 from celeriac⁶⁸⁹ as well as Aes h 1 from horse chestnut seeds (Gadermaier, unpublished data) (Figure 53B).

Art v 3, the nsLTP from mugwort pollen demonstrates frequent IgE cross-reactivity to homologous molecules in plant food (e.g., Pru p 3) (Figure 53C). By contrast, source constrained sensitizations are observed for the major *Parietaria* allergen Par j 2 and the minor allergen Amb a 6.⁶⁹⁰⁻⁶⁹²

The Ole e 1-like protein Pla l 1 from plantain presents low sequence similarity to other family members and is thus not involved in cross-reactivity. By contrast, substantial cross-reactivity is observed for Che a 1 and Sal k 5 due to 74% sequence identity (Figure 53D).^{358,678,681}

Pollen-food syndromes mediated by weeds are mainly involving mugwort and ragweed allergic patients. In addition to oral

allergy syndromes, more severe clinical pictures as observed, e.g., in the celery-mugwort-spice syndrome are reported. Cross-reactive allergens were identified in the family of nsLTPs, profilins, defensin-like proteins and high-molecular weight allergens including CCDs.^{669,689,690,693}

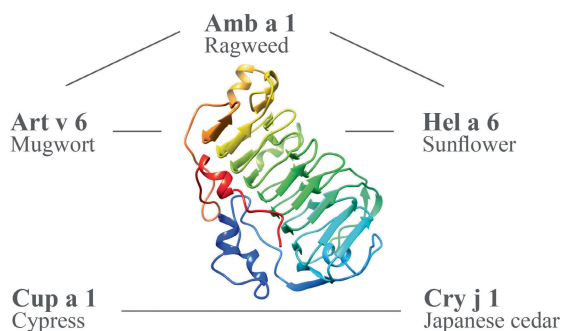
5 – Clinical management

Diagnosis of weed pollen allergy can be difficult due to frequent polysensitization and inconclusive anamnesis owing to overlapping flowering seasons with other pollen. Thus molecule-based allergy diagnosis is particularly advantageous and work-ups facilitating diagnosis of some weed pollen allergies are presented in (Figure 54).

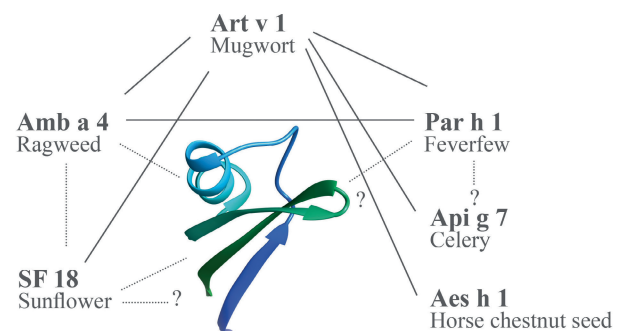
Case history

Weed pollen allergic patients typically present seasonal respiratory symptoms (rhinitis and/or conjunctivitis and/or asthmatic symptoms, sometimes also itching of the throat and/or contact urticaria). Since clinical symptoms coincide with flowering periods of the respective weeds (Figure 52), principal information can be obtained by narrowing down the eliciting allergen source(s).

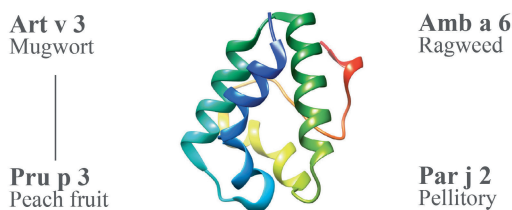
(A) Pectate lyases



(B) Defensin-like proteins



(C) Lipid transfer proteins



(D) Ole e 1 like-proteins

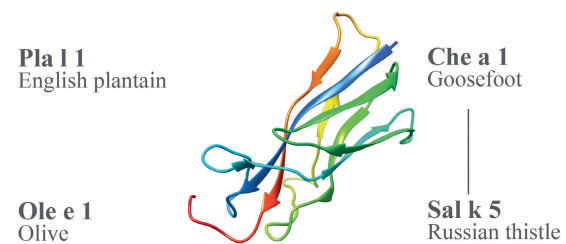


FIGURE 53 (A) Model of Amb a 1.0101 (template 1PXZ); (B) Structure of Art v 1.0101 defensin-domain (2KPY); (C) Structure of Art v 3.0201 (6FRR); and (D) Structure of Pla l 1.0101 (4Z8W). Models were generated using Swiss-Model (www.swissmodel.expasy.org) and ribbon cartoons are shown using UCSF Chimera (www.cgl.ucsf.edu/chimera). Lines represent documented IgE cross-reactivity, dotted lines represent potential IgE cross-reactivity based on high sequence identity. Lack of lines indicates absent IgE cross-reactivity.

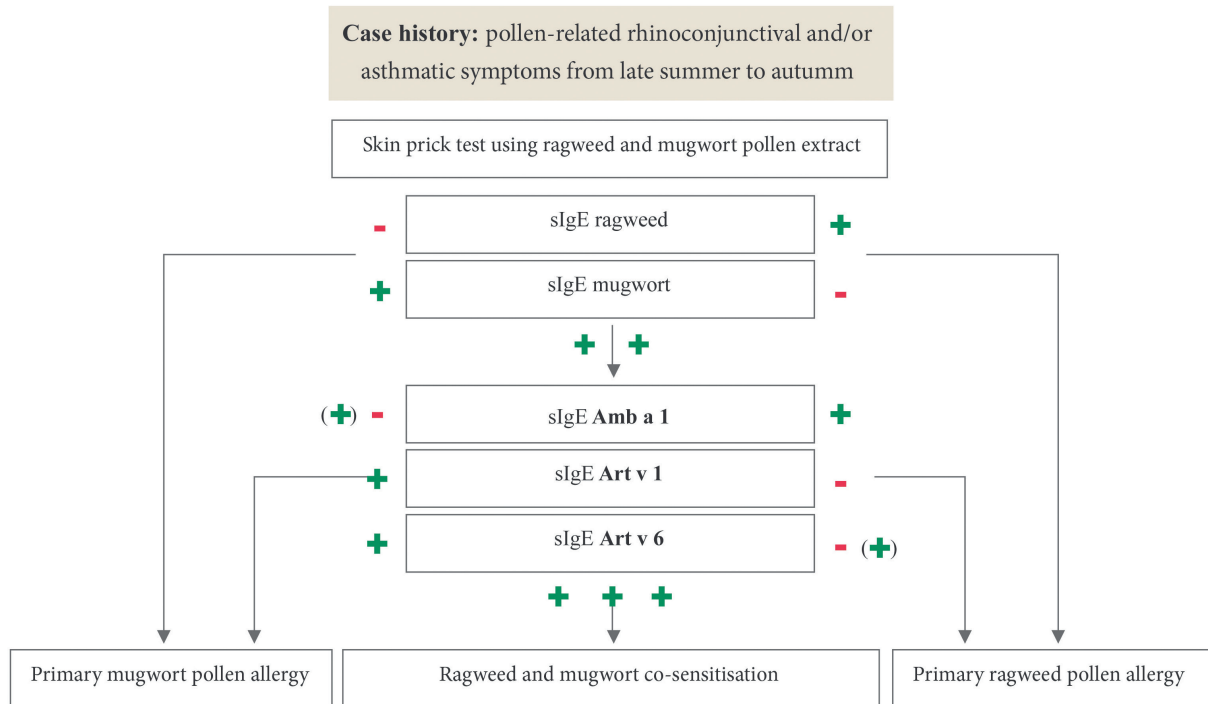
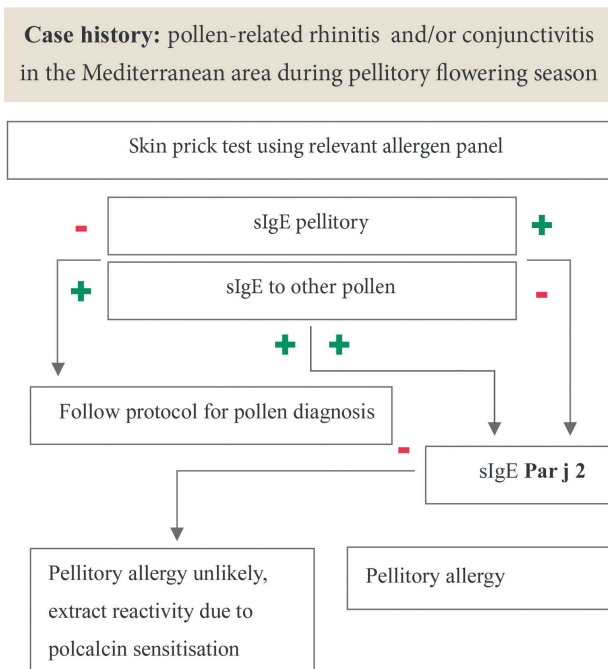
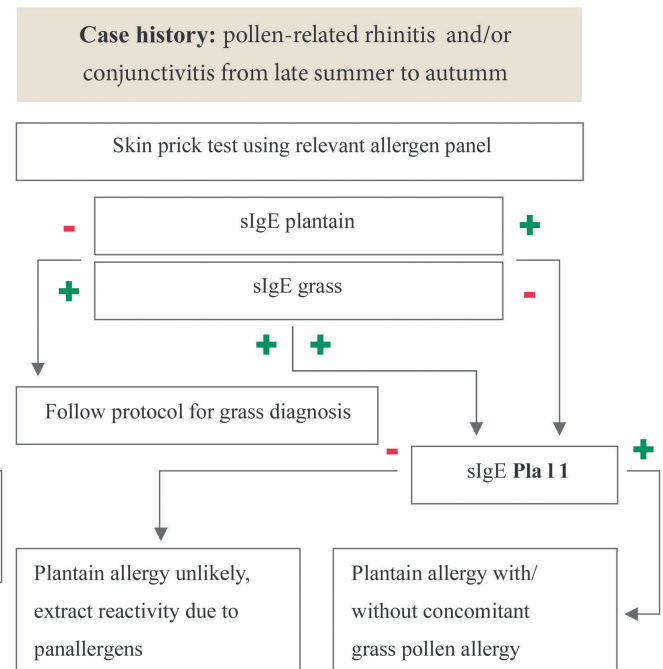
(A) Ragweed and mugwort**(B) Pellitory****(C) English plantain**

FIGURE 54 Diagnostic work-up for (A) ragweed and mugwort, (B) pellitory and (C) English plantain pollen allergy

Skin prick test (SPT)

The choice of commercially available weed pollen extracts for SPT is highly depending on pollen exposure and clinical references. Based on current GA2LEN recommendations for

harmonization of skin prick tests in Europe, mugwort, ragweed and pellitory are included in routine diagnostic panels, while plantain and allergenic pollen of the Amaranthaceae family are not considered. Since the allergological relevance can considerably

vary between regions, local modifications are, however, useful and necessary. Since *Parietaria* extracts are virtually missing profilin, a positive SPT with this weed is generally diagnostic of primary sensitization unless the patient is sensitized to the pollen pan-allergen polcalcin.⁶⁹⁴

IgE testing

Apart from *in vitro* testing using weed pollen extracts, molecule-based approaches offer a valuable tool for refined diagnosis limiting unspecific results due to polysensitizations. All major allergens of weed pollen are commercially available for diagnosis using the single component ImmunoCAP Specific IgE test, except for Che a 1, which is only present in multiplex arrays (ImmunoCAP ISAC and ALEX²) (Table 18). Components are available as nonglycosylated recombinant molecules (e.g., rPla 1 1, rPar j 2), CCD (N-glycan)-free, natural molecules like nAmb a 1 (nonglycosylated), nArt v 1 (O-glycosylated), and CCD-containing nSal k 1 (N-glycosylated). Art v 1, Art v 3 and Che a 1 are either provided as purified natural molecules (ImmunoCAP Specific IgE test) or recombinant proteins (ALEX²), respectively. To discriminate ragweed and mugwort primary sensitization, Art v 6 and Amb a 4 would be useful diagnostic markers as they are homologues of the respective major allergens (but these components are limited available for routine diagnosis). In the case of Sal k 1, false-positive results might arise due to N-glycosylation. Mer a 1 is so far the only allergen identified from Annual mercury and owing to expected broad IgE cross-reactivity with other profilins should not be considered a marker allergen for the source (see Chapter C01).

Therapeutic options

Besides recommendations to generally limit exposure during pollen season, symptomatic treatment is considered a first line of

defence for weed pollen allergic patients. In addition, allergen immunotherapy (AIT) is recommended based on the identification of the primary sensitizer using highly specific marker allergens. Weed allergic patients frequently present multiple sensitizations, and thus typically allergen sources triggering most profound symptoms are selected for therapeutic interventions.

Various subcutaneous extracts of weed pollen (single and combination products) and recently also a tablet for sublingual immunotherapy (ragweed allergen), are available in the U.S. (www.fda.gov), in Canada and in Europe.

In addition, individual recipes may be prescribed for allergens not mentioned in these regulations. However, economic considerations, regulation and standardization requirements are prompting some providers to withdraw their weed pollen products.

6 – Clinical Cases

Case 1 (educational)

Clinical History: A 42-year old man from Central Europe with increasing rhinoconjunctival symptoms from February to September for 12 years; additionally asthmatic symptoms for 2 years occurring only between May and September.

Test with extracts: Histamine-equivalent sensitization to tree pollen (hazel, alder, birch, ash) and to mugwort; weak skin prick reactivity to ragweed and goosefoot; strong sensitization to grass pollen. Specific IgE to birch (10.7 kU/L), ash (1.31 kU/L), grass (17.7 kU/L), mugwort (10.4 kU/L) and ragweed pollen (1.26 kU/L).

Test with molecules: The patient had positive IgE results to Bet v 1 (13.2 kU/L), Ole e 1 (2.56 kU/L), Phl p 1 (9.26 kU/L), Phl p 5 (3.58 kU/L), Art v 1 (12.8 kU/L), Art v 3 (10.8 kU/L) and Amb a 1 (0.68 kU/L).

TABLE 18 Molecular components for diagnosis of weed pollen allergy

Allergenic source	Specific IgE component	Protein family	Diagnostic use
Ragweed	nAmb a 1	Pectate lyase	Marker for ragweed, IgE cross-reactivity with Art v 6 from mugwort and Hel a 6 from sunflower
Ragweed	rAmb a 4[#]	Defensin-like protein	Minor ragweed allergen with partial IgE cross-reactivity to Art v 1
Mugwort	nArt v 1/rArt v 1	Defensin-like protein	Marker for mugwort, partial cross-reactivity with Amb a 4 (ragweed), Par h 1 (feverfew) and SF18 (sunflower)
Mugwort	nArt v 3/rArt v 3	nsLTP	Cross-reactive with nsLTP from food e.g. Pru p 3 from peach or Cor a 8 from hazelnut
Mugwort	nArt v 6*	Pectate lyase	Amb a 1 cross-reactive allergen
Pellitory	rPar j 2	nsLTP	Highly specific marker allergen for pellitory sensitisation
English plantain	rPla 1 1	Ole e 1-like protein	Highly specific marker allergen for English plantain
Goosefoot	rChe a 1[§]	Ole e 1-like protein	Marker for goosefoot, partial IgE cross-reactivity with minor <i>Salsola</i> allergen Sal k 5
Russian thistle	nSal k 1	Pectin methylesterase	Marker allergen for Russian thistle allergy, natural allergen contains N-glycans (result might be false positive if patient is CCD positive)

nsLTP, non-specific lipid transfer protein.

Marker allergens shown bold, #available only on ALEX2, *test not commercially available, §available only in multiplex analyses.

Conclusion: The patient presents a complex pollen sensitization profile involving tree, grass and weed pollen. Symptoms in autumn are mainly caused by mugwort pollen; primary sensitization to ragweed is not indicated as Amb a 1 levels are very low and might arise due to the cross-reactive molecule Art v 6 in mugwort.

Case 2 (original)

Clinical History: A 20-year old woman from Western Austria with severe rhinoconjunctival symptoms from end of April to the middle of September since early childhood.

Test with extracts: The patient had a weak SPT positivity with hazel pollen, histamine-equivalent reactivity to grass pollen and strong sensitization to English plantain, all other standard inhalatory allergens negative. Positive *in vitro* IgE test to grass (14.2 kU/L) and plantain pollen (14.6 kU/L).

Test with molecules: The patient had positive IgE results to Phl p 1 (9.72 kU/L) and Pla l 1 (15.5 kU/L), while Phl p 7, Phl p 5, and Phl p 12 were negative. Multiplex results showed sensitization to Cyn d 1 (6.20 ISU), Phl p 1 (29.2 ISU), Phl p 2 (10.2 ISU), Phl p 11 (5.25 ISU), and Pla l 1 27.2 ISU.

Conclusion: In addition to grass pollen, the patient presents a weed pollen allergy to English plantain, which explains symptoms observed in autumn after the grass pollen season.

Case 3 (educational)

Clinical History: A 36-year-old male living in northern Italy with a long lasting history of mild seasonal rhinitis from the beginning of May to the end of June experiences severe rhino-conjunctivitis associated with asthma as soon as he moves to Sicily for work at the beginning of March 2013. Gradual symptoms worsening force the man to ask for assistance at an Emergency Department where systemic corticosteroids were administered.

Test with extracts: Strong skin reactivity to pellitory pollen was observed (12 mm mean wheal diameter) along with a weak sensitivity to grass pollen (3 mm).

Test with molecules: The patient had positive IgE results to Par j 2 (37.3 kU/L), Phl p 1 (0.88 kU/L), Phl p 5 (0.41 kU/L).

Conclusion: Allergy to pellitory pollen is diagnosed, which was caused by high pollen exposure in Southern Italy.

7 – Research and future perspectives

Further research on weed pollen allergy includes the following:

- In addition to sunflower, an allergenic cross-reactive pectate lyase was identified in feverfew pollen.⁶⁷⁵
- Recently, two defensin-like proteins from horse chestnut (Aes h 1) and celeriac (Api g 7) were described as novel allergens. Clinical reactivity to horse chestnut is elicited by Aes h 1 and considered a consequence of primary sensitization to Art v 1 from mugwort pollen (Gadermaier et al, unpublished). The involvement of pectate lyases and defensin-like proteins in food allergy remains to be investigated.
- In a murine model, virus-like particles expressing shielded Art v 1 were hypoallergenic, which could be useful for future preventive treatment targeting T cells.⁶⁹⁵
- Structural IgE-binding epitopes of Art v 3 were recently identified by NMR and stable epitope variants revealed strongly hypoallergenic candidate molecules for use in allergen immunotherapy.⁶⁹⁶

In general, effects of climatic changes will lead to a considerable increase in weed pollen load and thus allergic reactions.^{653,654}

In light of this, there should be efforts to stop the continuing withdrawal of therapeutic possibilities for weed pollen allergic patients.

Clinical Relevance

- Art v 3 reactivity frequently indicates LTP sensitization and may be associated with oral allergy syndrome.
- Par j 2 is an excellent marker molecule for Parietaria allergy due to its high specificity
- The habitat and flowering period of plantain coincides with grass and should be thus consequently tested especially if symptoms persist for some weeks after the grass pollen season. Pla l 1 is a reliable marker molecule while Ole e 1 should NOT be used as a surrogate diagnostic as it lacks IgE cross-reactivity.

B04 - Dust mite allergy

Thomas Platts-Mills, Luis Caraballo, Alain Jacquet, Josefina Zakzuk

Highlights

- House dust mite allergy is an important risk factor for rhinitis and asthma.
- Most recognized house dust mites are *Dermatophagoides pteronyssinus*, *Dermatophagoides farinae* and *Blomia tropicalis*.
- In the majority of cases, a skin test with mite extracts is able to detect sensitization and define the specificity of immunotherapy in asthmatic patients.
- However, the use of component-resolved diagnosis could be useful when genuine sensitization is not clear and has to be defined.

1 - The allergen sources

Within the phylum Arthropoda there are three main taxonomic divisions with allergological importance (Figure 55). Among crustaceans, several species are important sources of food allergens. Also, both classes, insects and arachnids, contain species, which are sources of inhalant allergens. Arthropods separated from other animals approximately 600 million years ago (MYA) and the major classes were established within 100 million years. Dust mites and cockroaches, for example, have been separated for at least 400 million years and not surprisingly most of these allergens are so different in their primary sequences that they do not cross-react. This should be compared with the mammals, which separated approximately 65 MYA and still have extensive similarity among proteins. Of the hundreds of thousands of arthropod species only a few have been recognized as significant sources of indoor allergens. Indeed, more than 90%

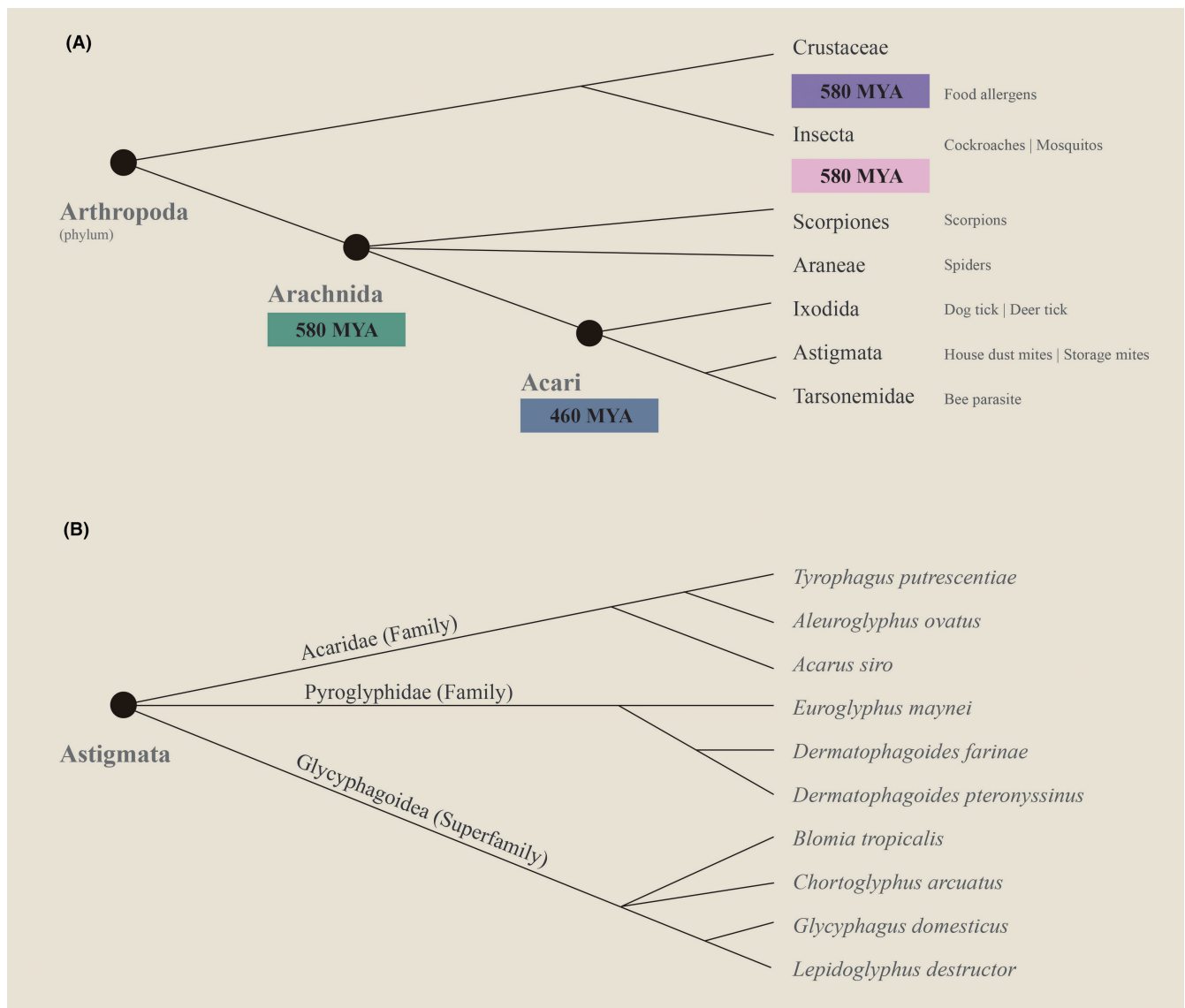


FIGURE 55 A. Phylogenetic tree of the main arthropod taxonomic groups. B. Evolutionary relationship of the main allergenic house dust and storage mite species

of the literature is related to five genera: *Dermatophagoides*, *Blomia*, *Euroglyphus*, *Blatella*, and *Periplaneta*. One important aspect of the house dust mite (HDM) allergenic sources is that they can play a very important role in asthma, without their role being obvious to the patients.

While there are many possible explanations for this, the most obvious ones are perennial exposure, that the organisms are small and often not noticed and that particles carrying these allergens are sufficiently large not to remain airborne for more than a few minutes after disturbance.⁶⁹⁷ Because the role of exposure to mite or cockroach allergens had not been obvious to patients, learning about these species has been essential to increase our knowledge on the causal role of allergen exposure in asthma. The relevance of particle size became obvious shortly after the purification of Der p 1 and the development of accurate assays for this allergen.⁸ For *D. pteronyssinus* and *D. farinae*, allergens become airborne via fecal particles and fragmented mite bodies in household dust.⁶⁹⁸

These allergen-carrying particles are particularly relevant for the type of exposure, as allergenic proteins with a size of 15,000 to 50,000 Daltons are not volatile and significant exposure can only occur via particles. Mite fecal pellets have an average diameter of 20–30 μm ⁶⁹⁹ and those with a size between 2–6 μm can be transported into small airways.⁷⁰⁰ The nature of these particles is relevant to, both, the induction of an IgE response and the subsequent contribution to inflammation of the nose and lungs. For dust mite particles, they not only carry a high concentration of several allergens but also are an important source of microbial compounds (at least LPS, β -glucans and chitin) capable of eliciting strong innate immune responses.

A significant feature of the epidemiology of HDM allergens is that there are areas of the world where some species are more present, for example, the high prevalence of *B. tropicalis* in the tropics. Both climate and housing conditions play a major role in these differences because mites absorb moisture from their environment and are absolutely dependent on the level of humidity in the air or on either carpets or upholstered material, which will retain humidity for long periods of time. In addition, the immature forms of *D. farinae* can withstand longer periods of dryness than *D. pteronyssinus*.

Before 1960, it was well recognized that house dust contained allergens other than those derived from domestic or pet animals as well as pollens or fungi; indeed, several groups had attempted to identify a house dust atopen by immunochemical analysis of house dust extracts. However, the breakthrough was made by microscopic identification of dust mites in house dust. It was fitting that these observations were made in the Netherlands since the Dutch scientist Antonie van Leeuwenhoek had first described mites in 1693. In addition, to evidence that mites of the genus *Dermatophagoides* were the major source of allergens in house dust, Spieksma and Voorhorst also developed the technique for culturing these organisms.⁷⁰⁰ This in turn made it possible to manufacture dust mite extracts for commercial use and subsequently facilitated the purification of mite allergens.⁸

2 – The allergen families

Dust mites belong to the order Astigmata, which is part of the Arachnids (Figure 55). This order includes the well-known Pyroglyphidae family but also the Acaridae and a superfamily (Glycyphagoidea) then divided into three main families: Echimypodidae (*Blomia tropicalis*), Glycyphagidae (*Glycyphagus domesticus* and *Lepidoglyphus destructor*), and Chortoglyphidae (*Chortoglyphus arcuatus*). *Sarcoptes scabiei* (the scabies mite) is a member of the Sarcoptidae family, which has also been found as allergenic to humans. The mites generally recognized as house dust mites are *D. pteronyssinus*, *D. farinae*, *Euroglyphus maynei*, and *B. tropicalis*. However, four species of storage mites, which are best recognized as pests on farms or in food storage have also been recognized in house dust (Table 19). In addition, mites of the family Tarsonemidae may be found in significant numbers in house dust. The best evidence that a given mite species is relevant to allergic disease comes from studies in an area where a given species dominates all other mites in the house dust. This is true for *D. pteronyssinus* in the UK and New Zealand, for *D. farinae* in some areas of the United States, and for *B. tropicalis* in areas of South America and other tropical regions.^{701,702}

3 – Allergenic molecules. Epidemiology and function

Der p 1 was the first identified dust mite allergen in 1980, purified by conventional chromatographic techniques⁸; the purification of the Group 2 allergens Der p 2 and Der f 2 in 1989 was performed by immunoaffinity chromatography.⁷⁰³ Over the last 20 years, the techniques for cloning and sequencing proteins have become well-defined and much simpler. As a result, many mite-derived proteins have been described with convincing data about their amino acid sequence and the tertiary structure for some of them.^{704–708} More than 35 HDM allergen groups have been identified so far; this

TABLE 19 Common mite species found in house dust

Mite Species	Number of Identified Allergens*
House Dust Mites	
<i>Blomia tropicalis</i>	14
<i>Dermatophagoides pteronyssinus</i>	31
<i>Dermatophagoides farinae</i>	36
<i>Euroglyphus maynei</i>	5
Storage Mites	
<i>Acarus siro</i>	1
<i>Chortoglyphus arcuatus</i>	1
<i>Glycyphagus domesticus</i>	1
<i>Lepidoglyphus destructor</i>	5
<i>Tyrophagus putrescentiae</i>	15

functional classification was based on amino acid sequence and/or structural homologies. Some of the most studied groups are presented in (Table 20); other groups can be found in the WHO/IUIS Database (www.allergen.org).

Of note, proteomic analyses showed that Der p 1, Der p 2 and Der p 23 together with Der p 3, Der p 6, Der p 9, Der p 15 and Der p 28 represent the most abundant allergens in mite fecal pellets.⁷⁰⁹

In addition, the biological functions of some HDM allergens from groups 1 (Der p 1, Der f 1), 2 (Der p 2, Der f 2), 3 (Der p 3), 5 (Der p 5), 6 (Der p 6), 7 (Blo t 7), 9 (Der p 9), 12 (Blo t 12) and 13 (Der p 13, Blo t 13) were experimentally confirmed.⁴⁰

Component-resolved diagnosis using a collection of purified natural or recombinant HDM allergens greatly improved the characterization of IgE reactivity profiles for each HDM-allergic patient. sensitization patterns in random cohorts and birth cohorts evidenced clear serodominance of Der p 1/Der f 1, Der p 2/Der f 2 and Der p 23 (prevalence above 50%).⁷¹⁰ The IgE-binding frequencies for Der p 4, Der p 5, Der p 7, Der p 21 range from 20 to 40%. Seroprevalence below 20% is commonly measured for the other allergen groups.^{28,711,712} Also, there are calculations suggesting that IgE antibodies specific to Der p 1, Der p 2, and Der p 23 account for more than 80% of the IgE to *D. pteronyssinus*. IgE to middle-tier allergens (i.e., 4, 5, 7) and 21 only adds around 10% to the cumulative amount of mite-specific IgE, whereas the contribution of the other identified proteins is even weaker.^{708,713}

Monosensitizations to groups 1, 2 and 23 can be detected in 3-5% of the HDM allergic patients.⁷¹² In a general way, IgE levels to Der p 1/Der p 2/Der p 23 were higher in HDM allergic patients developing asthma in comparison to those suffering from allergic rhinitis only. Moreover, sensitization profiles measured in HDM allergic asthmatics were broader than those detected in allergic rhinitis cohorts. The percentage of sensitization to mid-tier allergens such as Der p 5, Der p 7 or Der p 21 is also higher in HDM allergic patients developing asthma.^{711,712} The pattern of IgE sensitizations and HDM allergen-specific IgE levels displayed clear geographical variability, for example, Blo t 2, Blo t 5 and Blo t 21 are⁷¹⁴ serodominant in allergic patients living in tropical areas and sensitized to *Blomia tropicalis*,^{714,715} strengthening the concept of global personalized medicine to improve allergen immunotherapy (AIT) outcomes.^{712,715} Another interesting issue is the heterogeneity and molecular spreading of the IgE responses to mite allergens, which is further analyzed in Chapter A07 on "Basic and theoretical aspects of allergens."

Der p 1 and Der p 2 are present in fecal particles and strongly associated with asthma. In addition, for Der p 1, there is specific evidence about the effects of reducing exposure from 13 to 0.2µg/g on symptoms among mite allergic individuals.⁷¹⁶ Thus, for these allergens there is good evidence of their important clinical role in rhinitis and asthma. Clearly, it will be very difficult to have an accurate assessment of the relative importance of all HDM allergenic components in the development of allergic diseases, but the trends

TABLE 20 Main HDM allergen groups, taken from WHO-IUIS Database (www.allergen.org)

Allergen group	Biological function	<i>D. pteronyssinus</i>	<i>D. farinae</i>	<i>B. tropicalis</i>	<i>E. maynei</i>
1	Cysteine protease	24*	10	2	2
2	MD-2-like lipid binding protein	15	17	5	2
3	Trypsin-like serine protease	1	1	2	1
4	Amylase	1	1	1	1
5	Lipid binding protein	2	1	1	
6	Chymotrypsin-like serine protease	1	1	1	
7	Lipid binding protein	1	1	1	
8	Glutathione-S-Transferase	1	1	1	
9	Collagenase-like serine protease	2			
10	Tropomyosin	1	1	1	
11	Paramyosin	1	1	1	
12	Peritrophin			1	
13	Fatty acid binding protein	1	1	1	
15	Chitinase	1	1		
18	Chitinase	1	1		
21	Lipid binding protein	1	1	1	
23	Peritrophin-like protein	1	1		
31	Cofilin	1	1		
32	Pyrophosphatase	1	1		
33	α-tubulin	1	1		
35	MD2-like lipid binding protein		1		

*Number of isoforms

of basic and clinical research on HDM allergy indicate that it could be possible.²⁴ For example, a recent study found associations between the IgE sensitization to the novel allergen Der p 37 and asthma.⁷¹⁷

4 – Sensitization to individual allergens and their clinical relevance

Most clinically relevant allergenic molecules have been identified using serum from allergic patients because, by definition, they should bind specific IgE. However, most of them have been characterized only in terms of IgE-binding frequency (allergenicity) (Figure 56) with less robust evidence about allergenic activity. Since allergenic activity (the property of inducing inflammation, not necessarily IgE-mediated) is closer to clinical relevance than IgE-binding alone, during the last years some groups have focused their efforts on determining the allergenic activity of individual allergenic molecules, as was done before for allergenic extracts. Several assays have been useful to explore the allergenic activity of HDM molecules, among them *in vivo* and *in vitro* provocation tests, case-control studies, experimental animal models, mechanisms of action, avoidance studies and, of course, IgE-binding.⁵⁵ Although important advances have been made in this field, only a few HDM allergenic molecules have been evaluated in terms of allergenic activity; (Figure 57) shows examples from *D. pteronyssinus* and *B. tropicalis*.

Non IgE-mediated allergenic activity of HDM allergens

The inflammatory response triggered by HDM allergens is commonly mediated by the allergen binding to IgE immobilized to the cell membrane, inducing cell activation and the release of a plethora of pro-inflammatory factors; this mechanism seems to be relevant for all allergens. In addition, some allergens can stimulate innate immune inflammatory responses acting directly on immune or non-immune cells, without an IgE-dependent mechanism. The sum of

both reaction types builds the allergenic activity of an IgE-binding molecule.

The intrinsic allergenic activities of HDM allergens stimulate key innate immune responses in the skin or airway epithelium leading to the release of epithelial-derived proinflammatory cytokines and innate alarmins such as IL-1 α / β , GM-CSF, IL-25, IL-33 and TSLP.⁷¹⁸

This pro-Th2 environment is central for the development of the HDM allergic response. To date, deciphering the innate sensing of HDM allergens remains extremely challenging by their natural association with microbial/environmental compounds present in mites and house dust, including LPS, β -glucans or chitin, which are potent stimulators of innate immune signaling. The cysteine proteases from group 1 HDM allergens and group 3, 6 and 9 serine proteases are able to disrupt epithelial barrier integrity through cleavages of tight junction proteins.⁷¹⁹ Whereas HDM serine protease allergens can directly activate protease-activated receptor (PAR)-2 and -4, Der p 1 indirectly stimulates PAR-1/PAR-4 signaling pathways through their canonical activator thrombin. This Der p 1-Thrombin-PAR-1/-4 axis generates TLR4-dependent reactive oxygen species (ROS) leading to the release of IL-33.⁷²⁰ Der p 1 disrupts the lung homeostasis through proteolysis of surfactant proteins (SP-A/D) or protease inhibitors (elafin, α -antitrypsin). Furthermore, it cleaves key receptors involved in Th1 responses such as CD40, DC-SIGN, and CD25⁷²¹ or in the control of IgE production (CD23).^{722,723} Finally, nociceptors, transient receptor potential vanilloid 1 (TRPV1)+ sensory neurons, represent the primary sensors of HDM-associated cysteine protease activity and the activation of sensory neurons is necessary for the initiation of the HDM allergic response.⁷²⁴ While the key role of the LPS/TLR4 axis in the HDM airway inflammation has been evidenced,⁷²⁵ HDM allergens with fatty acid/lipid-binding capacity could represent potent activators of TLR2 and/or TLR4 signaling. Group 2 mite allergens, having structural homology with myeloid differentiation factor-2 (MD-2), the TLR4 co-receptor, can present LPS to TLR4.^{317,704} However, their large hydrophobic pocket can transport other lipid

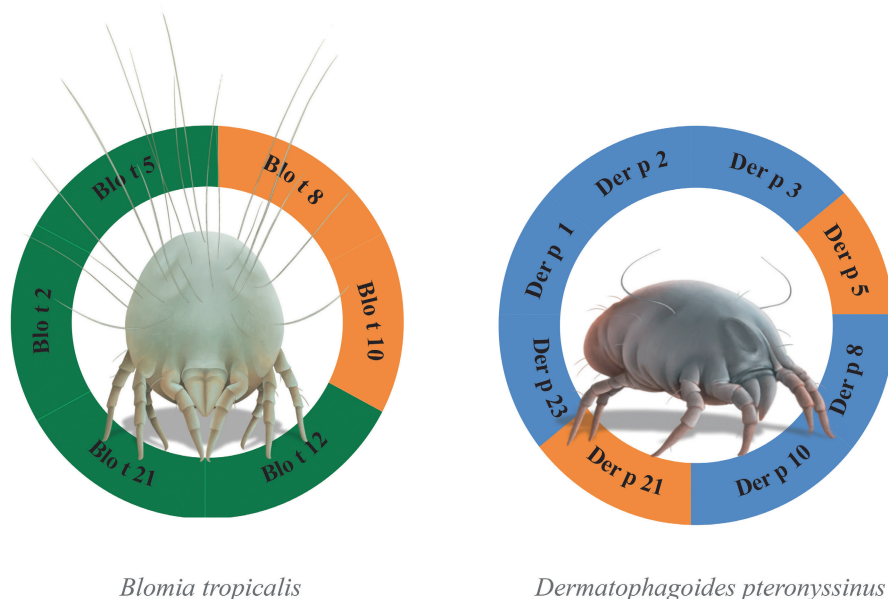
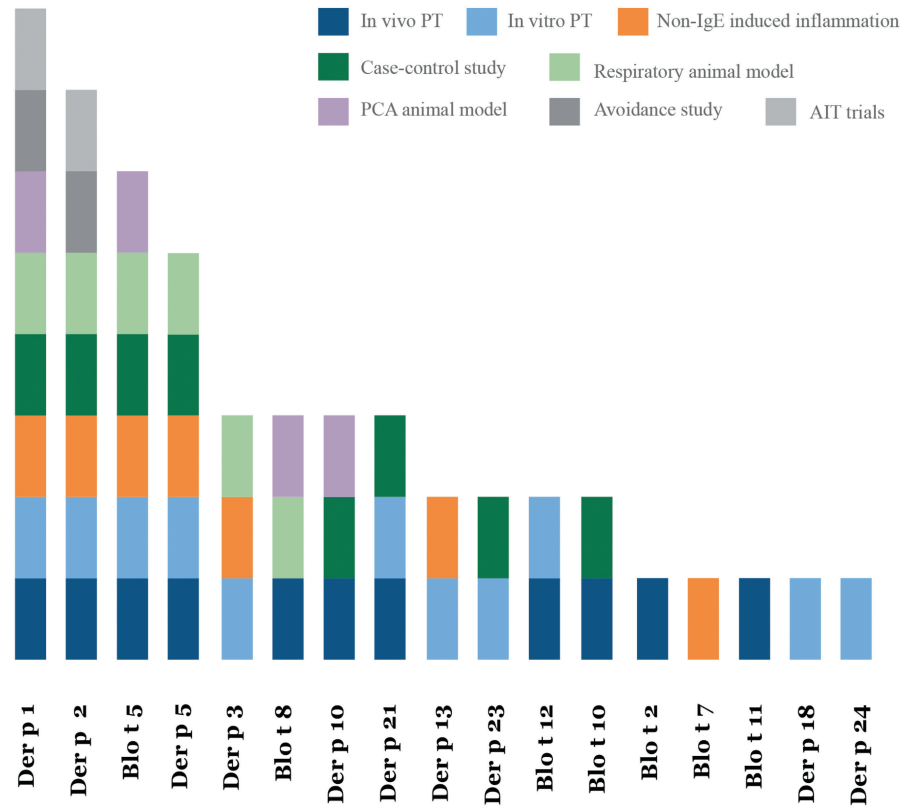


FIGURE 56 Relevant house dust mite allergens. Those with experimentally detected cross-reactivity with *Ascaris* are shown in orange. In addition, Blo t 5 and Der p 5 have moderate cross-reactivity, and there is high cross-reactivity among *Dermatophagoides* species.

FIGURE 57 Allergenic activity assays completed for house dust mite IgE-binding molecules. PT: Provocation test. PCA: Passive cutaneous anaphylaxis. AIT: Allergen immunotherapy



cargos than LPS to trigger TLR2/4 signaling pathways. Recombinant forms of Der p 5, Blo t 7, Der p 13 and Der p 21 stimulate TLR2 signaling pathways.^{474,726-728} Serum amyloid A1 (SAA1) can sense Der p 13 or Blo t 13 to promote pulmonary type 2 immunity.³⁸ HDM allergens from groups 12 and 23 or 15 and 18 could stimulate chitin-dependent innate immune mechanisms according to their sequence homologies with chitin-binding peritrophins or glycosyl hydrolase family 18 chitinases, respectively. However, the chitin-binding capacity of HDM allergens was only evidenced for Blo t 12.⁷²⁹ Finally, the HDM group tropomyosins can modulate the HDM airway inflammation through interactions with Dectin-1 expressed in airway epithelium.⁷³⁰ More recently, the pro-inflammatory activity of Der f 38 through TLR4 has been reported.⁷³¹ A list of some HDM allergens innate mechanisms of action is presented in (Table 21).

5 – Clinical Management

Diagnosis of sensitization

As stated in the introduction, the role of dust mite allergy in asthma is generally not obvious to all patients. Indeed, histories of specific allergy to mites are not usually clear. Many patients will report sneezing on awakening or sneezing during house cleaning. During vigorous cleaning they may also notice eye irritation or wheezing, but conjunctivitis is not a common symptom of dust mite allergy. Skin prick testing is the primary means of diagnosis, and dust mite extracts are included in all inhalant panels. Most authorities would regard a wheal of 3mm greater than the negative control as

positive. The common practice is to test with both *D. pteronyssinus* and *D. farinae*. In some areas, one mite or the other is the dominant cause of sensitization, but in general testing for the two provides convincing positive or negative results. However, *D. pteronyssinus* extracts might lack important allergens and often show great variability regarding allergen composition.⁷³² Notably, intact Der p 23 or Der p 5 are absent in HDM commercial allergen extracts. Moreover, as these allergen extracts are standardized for group 1 and group 2 allergens, the diagnosis of patients sensitized to HDM allergens other than Der p 1/Der p 2 is very challenging. Component-resolved diagnosis based on the use of individual natural/ recombinant HDM allergens could solve these detection issues and could enhance the percentage of successful allergen immunotherapy through the stratification of HDM allergic patients.⁷³³

Also, testing with *B. tropicalis* has become a very useful routine in tropical regions. *In vitro* assays for IgE to dust mite are well established and the units are given in IU/ml or KA Units/L. *In vitro* testing for specific IgE can be done using extracts of *D. pteronyssinus* (Dp), *D. farinae* (Df) and *B. tropicalis* (Bt). For multiplex testing, assays are available from several manufacturers, for example, rDer p 1, nDer p 1, nDer f 1, rDer f 2, rDer p 2, rDer p 23 and rDer p 10 are available on ImmunoCAP ISAC112 (ThermoFisher Scientific, Uppsala, Sweden). Der p 1, Der p 2, Blo t 5 and Der p 10 are available on the ImmunoCAP Specific IgE test, but Der p 23 is only available on the ImmunoCAP Specific IgE test (d 209) in Europe. Serum assays can provide a wide range of positive results from 0.1 IU/ml to >300 IU/ml. There is also good evidence that wheal sizes and IgE titers are useful as risk predictors for allergic disease,

TABLE 21 Main non IgE-mediated allergenic activities of HDM allergens

Group	Allergen	Non IgE-mediated allergenic activity
1	Der p 1	Disruption of the epithelial barrier integrity
	Der f 1	Pro-thrombin, IL-33 maturation
	Blo t 1	Cleavage of airway antiproteases, SP-A/SP-D, CD23, CD25, CD40, DC-SIGN eliminate :
2	Der p 2	PAR-1/PAR-4; TLR4-ROS-IL-33 axis; TRPV1 ⁺ sens
	Der f 2	TLR 4, TLR 2 activation
	Blo t 2	
3	Der p 3	Disruption of the epithelial barrier integrity
	Blo t 3	PAR-2/PAR-4 activation
5	Der p 5	TLR2 activation
	Blo t 5	
7	Der p 7	TLR2 activation
	Blo t 7	
9	Der p 9	Disruption of the epithelial barrier integrity PAR-2/PAR-4 activation
10	Der p 10	Dectin-1 activation
13	Der p 13	TLR2, SAA activation
	Blo t 13	
21	Der p 21	TLR2 activation
31	Der f 31	TLR2 activation
38	Der f 38	TLR4 activation

also in combination with a rhinovirus infection in childhood.⁷³⁴ Although the criteria for judging sensitization can be defined convincingly, it is not so easy to define these criteria for the role of dust mites in individual cases. However, several sets of information can help. If the patient is only allergic to mites, or skin tests/IgE assays are much stronger for mites than for other allergens, it could be relevant for perennial symptoms. Although not widely accepted as a diagnostic procedure, a nasal provocation test with mite extracts is another important tool for defining the clinical relevance of sensitization and detecting cases of local rhinitis associated to negative skin tests. Also, conjunctival and nasal provocation tests with *B. tropicalis* have been suggested as a diagnostic procedure in the clinic.⁷³⁵ Measurement of mite allergens in dust from the house can be very helpful. However, the criteria of >2 µg Der p 1 per gram of dust for sensitization and >10 µg Der p 1 per gram of dust for severe symptoms should not be regarded as more than an orientation guide. Still, it is a major advantage to know the average levels of mite allergens in homes or apartments in the area where the patient lives. Cross-reactivity between *D. pteronyssinus* and *D. farinae* extracts is high but between *Dermatophagoides* and *B. tropicalis* is low. The use of species-specific components might be necessary in places like the tropics where co-exposure to both genera is common. Tropomyosin is the main cause of cross-reactivity among mites, cockroaches, shellfish and helminths (e.g., *Ascaris lumbricoides*), but Glutathione-S-Transferase may also be involved⁷³⁶ (Figure 58).

In the majority of cases skin test with mite extracts can detect sensitization and define the specificity of immunotherapy in asthmatic patients. However, the use of component-resolved diagnosis could be useful in special circumstances where genuine sensitization is not clear and has to be defined. Figures 59 and 60 represent algorithms that could be applied for diagnosing mite allergy in temperate and tropical countries. Not all suggested components are commercially available.

Management

The management of allergic disease in patients who are allergic to dust mites consists of several different phases, most of which are like those for many other inhalant allergens (Table 22). However, education and allergen avoidance require extra care because of the complex biology of dust mites, and the fact that their presence in the home is not visible. Therefore, significant education in relation to avoidance is needed.

There is a wide range of evidence that dramatically decreasing exposure to dust mite allergens can help both asthma and rhinitis related to dust mites. This comes both from controlled trials of avoidance and from moving patients to a sanatorium or a hospital-based allergen "free" unit.^{24,491,737,738} Some of the most dramatic results have come from sanatoria in the Alps, but these are complicated to interpret because exposure to animal dander and fungi, as well as mites will be reduced.⁷³⁸⁻⁷⁴⁰ In addition, most of these sanatoria have regular exercise regimes, which may also contribute to the improved lung function and decrease in nonspecific bronchial hyper-reactivity

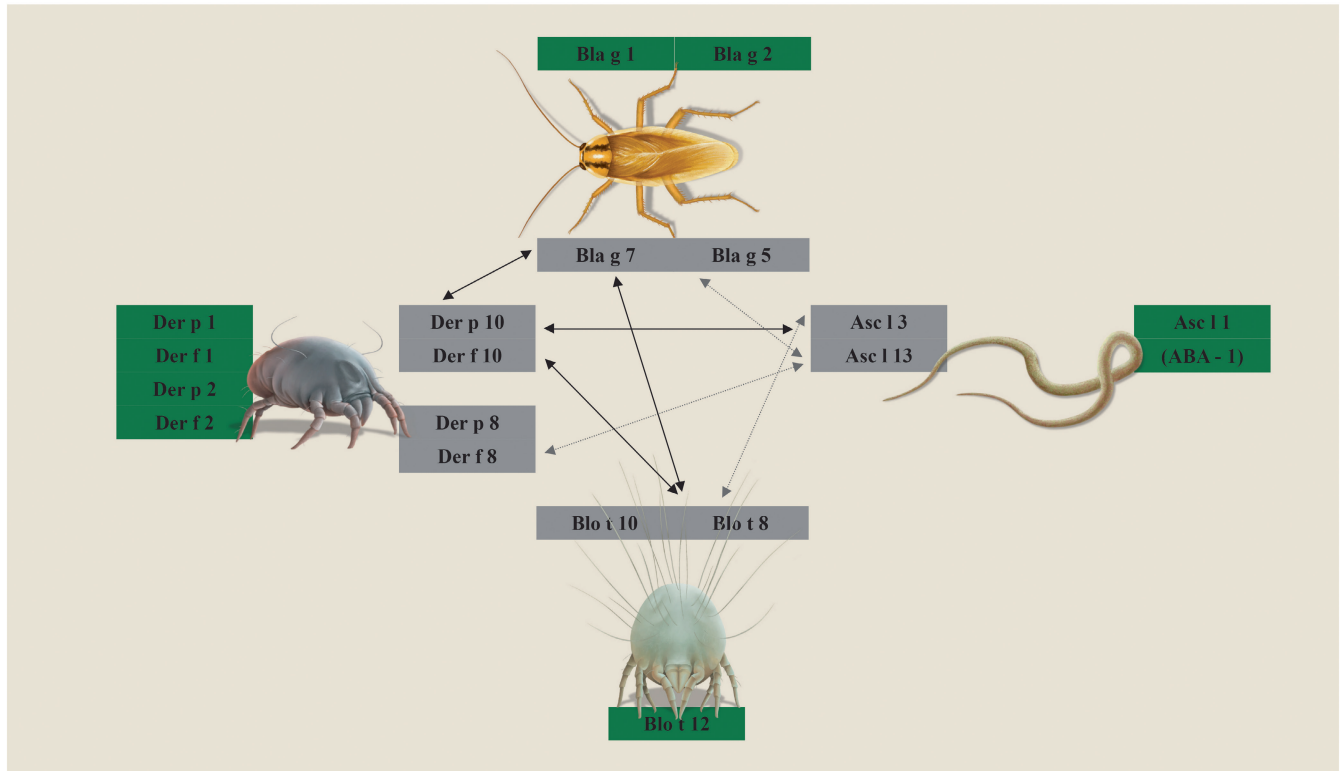
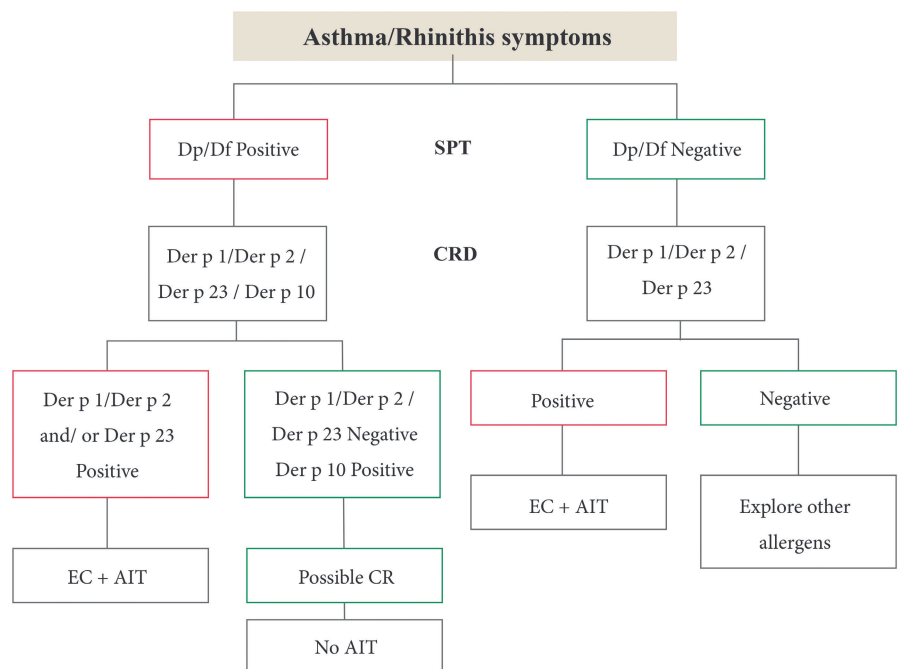


FIGURE 58 Clinically relevant cross-reactivity of mite allergens. Species-specific components are shown in green.

FIGURE 59 Possible decision algorithm for mite allergy in temperate countries. SPT: Skin Prick Test. CRD: Component Resolved Diagnosis. CR: Cross-reactivity. EC: Environmental Control. AIT: Allergen Immunotherapy. Dp: *Dermatophagoides pteronyssinus* extract. Df: *Dermatophagoides farinae* extract



(BHR). Following the initial study in Davos (Switzerland), further studies were carried out in Briancon (France) and Misurina (Italy). The studies in Misurina provided compelling evidence that there was a progressive decrease in inflammatory markers in parallel with decreases in BHR among mite allergic children who spent 3 months in the sanatorium. To study the role of mite allergens, mite allergic

asthmatics in London spent 3 or more months living in a hospital room, which had filtered air and was designed to have no sites where mites could live. The level of Der p 1 in dust from their homes was 13.6 µg/g, while dust from the hospital room had less than 0.2 µg/g. The patients not only improved their symptoms but also experienced a major decrease in BHR.⁷¹⁶

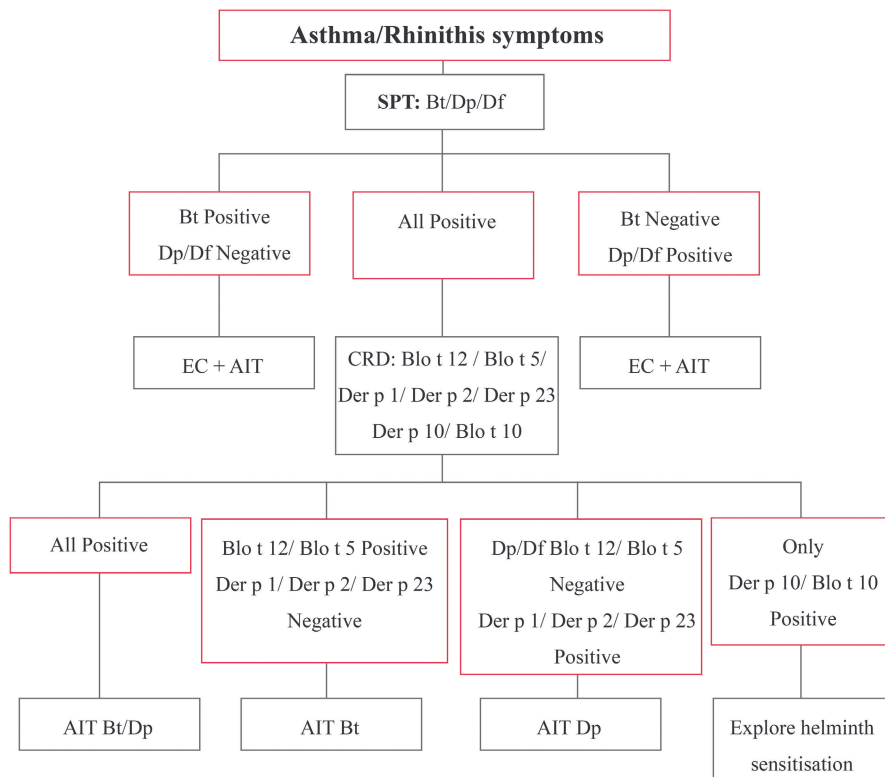


FIGURE 60 Possible decision algorithm for mite allergy in the tropics. SPT: Skin Prick Test. CRD: Component Resolved Diagnosis. CR: Cross-Reactivity. EC: Environmental Control. AIT: Allergen Immunotherapy. Dp: *Dermatophagoides pteronyssinus* extract. Df: *Dermatophagoides farinae* extract. Bt: *Blomia tropicalis*.

TABLE 22 Management of Allergic Disease Related to Dust Mite

A	Skin tests or serum assays for IgE antibodies using dust mite extract. CRD could be helpful to define allergen immunotherapy
B	Education about the relevance of these allergens to both acute and chronic symptoms
C	Advice about avoidance including a written plan and in some cases measurement of mite allergen in houses
D	A plan for pharmaceutical management for both the nose and the lungs
E	Subcutaneous or sublingual immunotherapy using dust mite allergen
F	In cases of asthma that are poorly controlled, treatment with a variety of monoclonal antibodies is now available and may also be recommended

6 – Clinical Case

Clinical history: A 32-year-old male faculty member in cardiology presented to clinic because of increasing episodes of shortness of breath during exercise. He was an enthusiastic runner (up to 10 miles) and had only developed symptoms since moving into a basement apartment one year earlier. His history did not include seasonal nasal symptoms or reactions on exposure to animals. When seen in clinic, his examination and spirometry were normal (Table 22).

Tests with extracts: Skin prick tests were strongly positive for *D. pteronyssinus* and *D. farinae* with 8×8 and 7×6 mm wheals. Blood count was unremarkable with absolute eosinophil count of 350. Total IgE 230 KU/L; IgE to *D. pteronyssinus* extract was 32 UA/ml. He was given a peak flow meter (Mini Wright) and instructed to record values before and after running, in addition, we arranged to collect samples from his apartment.

Test with molecules: Serum assays for components using ImmunoCAP ISAC (TFS, Uppsala, Sweden) showed Der p 1 IgE 28 ISU/ml; Der p 2 33 IgE ISU/ml; Der p 10 IgE (tropomyosin) <0.5 ISU/ml. Peak flow value (mean of 3 values) before running was 510 +20 liters/min and fell to 400 +40 liters/min and 320 +20 liters/min 2 and 4 minutes after running for 6 minutes. Dust samples from his apartment: 8.4 µg Der p 1/g carpet dust, 10.6 µg Der p 1/g sofa dust and 4.6 µg Der p 1/g bedding dust.

Treatment Advice and Outcome: Initially he was treated with albuterol inhaler, two puffs 10 min. prior to exercise and inhaled fluticasone 100 µg twice a day. In addition, he was advised to move to a second-floor apartment without carpeting and with minimal upholstered furniture. He was given routine advice about controlling mites in his bedding. He moved one month later and within 3 months his exercise breathing returned to normal. When seen 1 year later, he was no longer using inhalers and was without significant symptoms.

7 – Research and future perspectives

Given that HDM sensitivity is a major risk factor for asthma worldwide, the definition of the clinical impact of each of the

serodominant and mid-tier IgE-binding molecules is essential. Although there are no important difficulties for diagnosing HDM allergy using the whole extracts and some molecules, the complete profile of cross-reactivity among individual components remains to be experimentally analyzed. For example, groups 1 and 2 cross-reactivities are very high as these allergens share most of their conformational IgE-binding epitopes.⁷⁴¹ The complete mapping of these antigenic determinants would allow the identification of unique IgE-binding sites in Der p 1 or Der f 1 as well as Der p 2 or Der f 2.^{507,742} This research would improve the elucidation of HDM sensitization profiles.

Studies showing geographical variabilities in the patterns of HDM sensitization have been mainly focused on cohorts of Caucasian HDM allergic patients.^{712,713} The elucidation of the IgE reactivity profiles must be further broadened to populations from other ethnicities. This aim, together with the definition of the allergenic activity of additional IgE-binding molecules, could show the need for regional arrays for component-resolved diagnosis. In addition, since

the HDM allergen repertoire has been recently extended through “omic” analysis, recombinant forms of these new HDM allergens could complete the panels of molecules to improve the elucidation of the sensitization profile.

Future research on HDM allergy will keep the interest on the definition of the clinical impact of individual IgE-binding molecules,⁵⁵ and to investigate the mechanisms by which they induce symptoms. To achieve this, other technologic resources will be very helpful, but it is also necessary to better understand the relative role of IgE in the allergic responses, considering the increasing evidence of non-IgE-mediated inflammatory mechanisms associated to the allergenic activity of IgE-binding molecules. Therefore, a wider idea of the potential mechanisms of action of allergens will improve the research proposals in this field. In connection with this, it will be necessary to search for new ways to define the clinical impact of allergens, leaving the constraints of the “major and minor” allergen classification.

B05 – Cockroach allergy

Luis Caraballo, Thomas Platts-Mills, Anna Pomés, L. Karla Arruda

Highlights

- Cockroach allergens are strong inducers of sensitization and asthma.
- Clinically important species include American, German, Oriental, Asian, brown-banded and smoky-brown cockroaches.
- Bla g 2 and Bla g 5 have the higher frequency of IgE positivity among cockroach allergens, but there are important differences among individual patients and populations.
- Currently, diagnosis is performed by skin testing and/or measurement of specific IgE to cockroach, using crude extracts.

1 – The allergen sources

Cockroaches belong to the phylum Arthropoda; class Insecta, Order Blattaria or Blattodea. Species causing allergy symptoms such as asthma are listed in (Table 23). These ubiquitous scavenger organisms have inhabited the planet long ago and domiciliary species are currently a serious problem for humans. Those that live in human dwellings (around 25 species) include American, German, Oriental, and Asian, which, together with the brown-banded and the smoky-brown cockroaches are sources of important allergens, inducers of allergic asthma.⁷⁴³

sensitization to cockroach usually occurs by inhalation. Potential sources of relevant allergens in the environment include whole bodies, cast skins, secretions, egg casings, and fecal material. Level of exposure for increased risk of asthma symptoms is 8 U/g of dust (104 ng/unit for Bla g 1 and 40 ng/unit for Bla g 2⁷⁴⁴) and a US national study found that 10% of living rooms were above this point. There is inter-species cross-reactivity (e.g., American, German, Asian and Oriental) and extra-species cross-reactivity (“pan-allergy”) with several other arthropods such as crustaceans (shrimp, crab, and lobster), insects (silverfish, butterflies), arachnids (dust mites) and mollusks

(oysters, mussels, scallops, clams). Since both exposure and allergy to cockroach are very common, patients with asthma or rhinitis should be routinely evaluated for this type of allergy. Based on their molecular and biological properties, cockroach allergens have been distributed in several groups, most of them are shown in (Figure 61) and (Table 24).

2 – The allergen families

Group 1 allergens are composed by multiple consecutive amino acid repeats originated by gene duplication of an original 100 amino acid domain.⁷⁴⁵ Two repeats (each with 6 alpha-helices) define a basic structural unit and encapsulate a large and nearly spherical hydrophobic cavity that binds lipids such as palmitic, oleic, and stearic acids (Figure 62). There is cross-reactivity between Bla g 1, Per a 1 and homologous proteins from other cockroach species such as *P. fuliginosa* and *Blattella orientalis* and from other insects. The protein is most prevalent in the midgut, probably because the Bla g 1 gene is exclusively expressed by midgut cells. The presence of Bla g 1 in fecal particles makes this molecule, together with Bla g 2, a good marker of cockroach allergen exposure.

Group 2 Bla g 2 is an unusual (inactive) aspartic protease with strong allergenic properties. There is three times more Bla g 2 in cockroach feces compared with the whole extract. It was originally found to be the allergen with the highest IgE antibody prevalence among 5 cockroach allergens in a US population.⁷⁴⁶ The crystal structure shows that Bla g 2 has a bilobal shape.⁷⁴⁷ The antigenic structure of this allergen was analyzed by X-ray crystallography and site-directed mutagenesis, providing important information about function, key amino acids and carbohydrates determining epitopes and antigen-antibody interactions^{748,749} (Figure 62). Even a role for Bla g 2-associated glycans in allergen-induced immune reactions through basophil activation has been reported.⁷⁵⁰

Group 3 Allergens of this group show high homology to insect hemolymph proteins. Per a 3 induces IL-4 expression in PBMC from allergic patients and this correlates with skin reactivity and clinical symptoms.⁷⁵¹

TABLE 23 Clinically relevant cockroaches species

Family	Genus/species	Common name	Geographic distribution
Blaberidae	<i>Leucophaea maderae</i>	Madeira	Asia, Africa, America, Oceania
Ectobiidae	<i>Blattella germanica</i>	German	Mainly temperate dry zones
(formerly Blattellidae)	<i>Blattella asahinai</i>	Asian	Japan, tropical and subtropical
	<i>Supella longipalpa</i>	Brown-banded	Tropical
Blattidae	<i>Periplaneta americana</i>	American	Mainly tropical and subtropical
	<i>Periplaneta australasiae</i>	Australian	Cosmopolitan
	<i>Periplaneta brunnea</i>	Brown	Mainly tropical
	<i>Periplaneta fuliginosa</i>	Smoky brown	China, Russia, Korea, Japan, Australia and USA
	<i>Blattella orientalis</i>	Oriental	America, United Kingdom, Germany

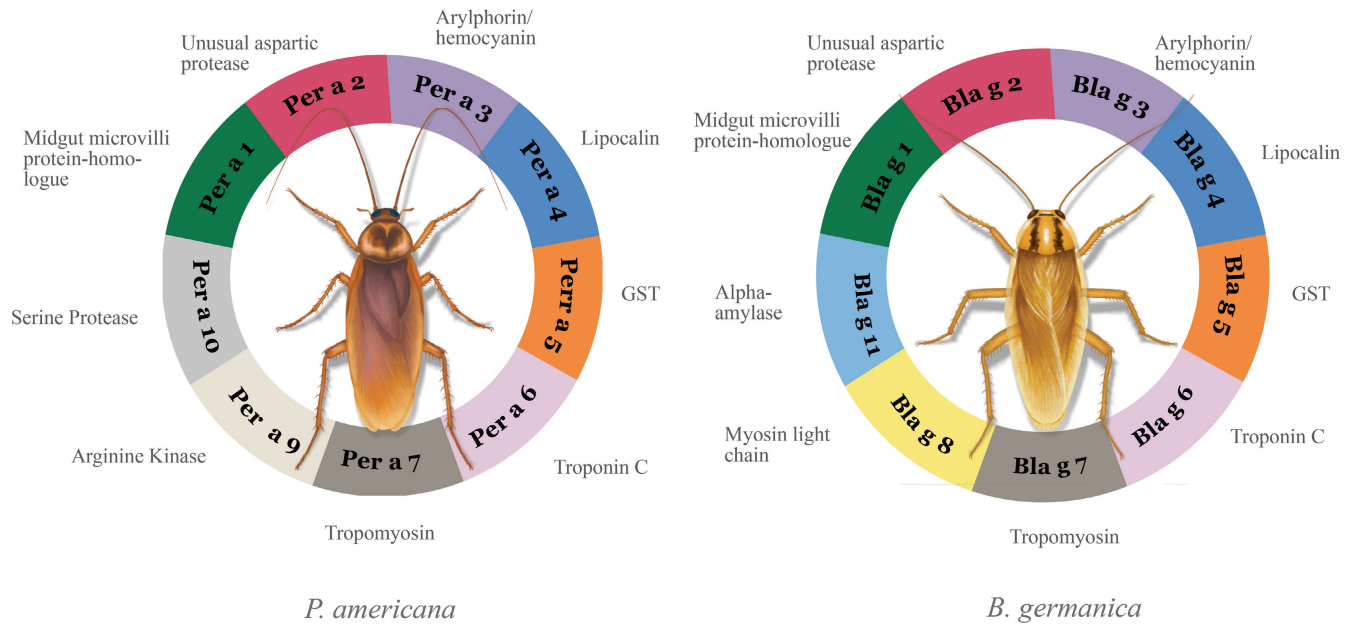


FIGURE 61 Some allergen components from American and German cockroaches. Homologous molecules have the same color. Complete in [Table 24](#)

TABLE 24 Cockroach allergenic molecules

Species	Allergenic molecule	Biochemical name	Prevalence of allergen-specific IgE among patients (%)	MW in kDa
<i>B. germanica</i>	Bla g 1	Midgut microvilli protein-homologue	20-50	21-90
	Bla g 2	Unusual aspartic protease	18-73	36
	Bla g 3	Arylphorin/hemocyanin	22	78.9
	Bla g 4	Lipocalin	11-47	21
	Bla g 5	Glutathione S-transferase	39-73	23
	Bla g 6	Troponin C	14-0	17
	Bla g 7	Tropomyosin	16	33
	Bla g 8	Myosin light chain	14	21
	Bla g 9	Arginine kinase	25-53	40
	Bla g 11	Alpha-amylase	29-73	57
	Bla g 12	Chitinase	30	58
	<i>P. americana</i>	Per a 1	Midgut microvilli protein-homologue	30 - 50, 100
Per a 2		Unusual aspartic protease	63	42
Per a 3		Arylphorin/hemocyanin	26-95	46-79
Per a 4		Lipocalin	15	17
Per a 5		Glutathione S-transferase	100	23
Per a 6		Troponin C	17	17
Per a 7		Tropomyosin	13-54	33
Per a 8		Myosin light chain	20	23
Per a 9		Arginine kinase	80-100	43
Per a 10		Serine protease	82	28
Per a 11		Alpha-amylase	83	55
Per a 12		Chitinase	64	45
Per a 13		Glyceraldehyde-3-phosphate dehydrogenase	3''3	36

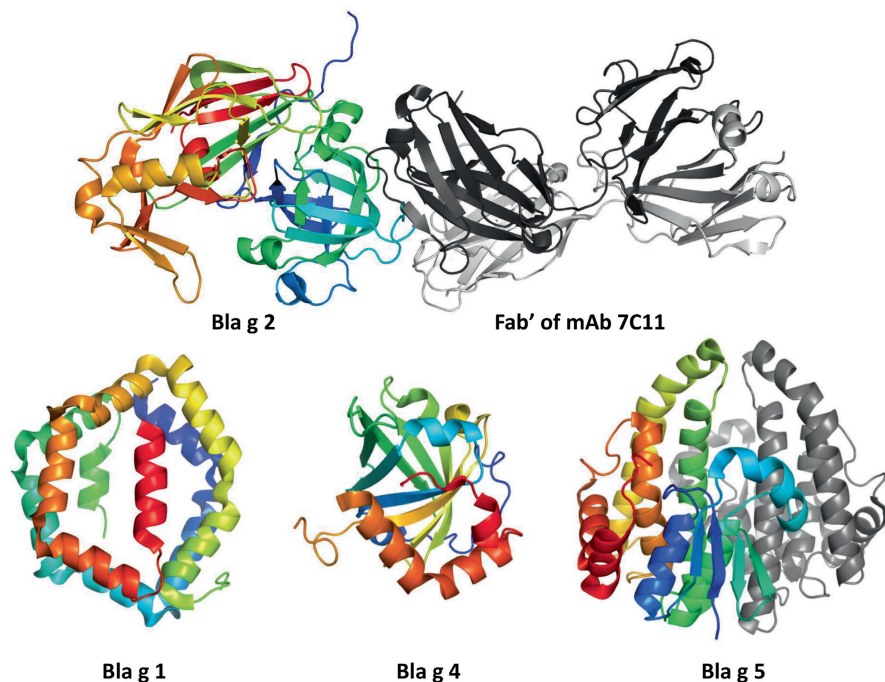


FIGURE 62 Crystal structures of the cockroach allergens Bla g 2 in complex with Fab' of the monoclonal antibody 7C11, Bla g 1, Bla g 4 and Bla g 5 (Protein Data Bank accession numbers are 2nr6, 7jrb, 3ebk, and 4q5r, respectively). The heavy and light chains of the mAb 7C11 Fab' are shown in dark and light grays, respectively. The allergen molecules are shown from the N- (blue) to the C-termini (red). One of the two molecules in the Bla g 5 dimer is shown in gray.

Group 4 Bla g 4 and Per a 4 are lipocalins. These molecules are very stable, and their structure consists of a C-terminal α -helix and a β -barrel enclosing an internal hydrophobic cavity that binds small ligands such as retinoids, glucocorticoids, and pheromones (Figure 62).

Group 5 Bla g 5 is a sigma class glutathione S-transferase (GST) that has a high IgE response in cockroach sensitized individuals (Figure 62). Cross-reactivity with GSTs of several sources (for example, Der p 8 and Tyr p 8) is known. However, lack of significant IgE cross-reactivity among GSTs from cockroach, mite and *Ascaris* was found in a temperate US population.⁷⁰⁸

Group 6 The allergens of this group are homologues to insect troponin C and vertebrate calmodulins (61% to 78% and 42% to 44% amino acid identity, respectively) and have 2 EF-hand calcium-binding domains. Interestingly, IgE binding to Bla g 6 has proven to be calcium dependent indicating that IgE preferably binds to one of the conformers.⁷⁵²

Group 7 Invertebrate tropomyosins are important pan-allergens among dust mites, chironomids, silverfish, crustaceans, nematodes and mollusks. Tropomyosins from *B. germanica* and *P. americana* have been described. IgE-binding frequency to cockroach tropomyosins are very different in some populations and this may reflect differences in environmental conditions (see chapter C05).

Group 8 Bla g 8 shares 81-84% amino acid sequence identity with the myosin light chain of several insects and the shrimp *Litopenaeus vannamei*. The myosin regulatory light chains are small acidic polypeptides noncovalently bound to the neck region of the myosin head, which regulate the interaction of the myosin head with actin.

Group 9 Per a 9 and Bla g 9 were identified as major allergens in Thai and US patients, respectively.^{753,754} Arginine kinase homologues have also been reported in the shrimp *Penaeus monodon*

(Pen m 2), *D. pteronyssinus* (Der p 20) and the Indian meal moth *Plodia interpunctella* (Plo i 1). There is evidence suggesting that arginine kinase is an invertebrate pan-allergen.⁷⁵⁵

Group 10 Per a 10 is a serine protease isolated from *P. americana* and an important allergen in Indian allergic patients.⁷⁵⁶ Other important allergens are also serine proteases (Der f 3, Der p 3, Der p 6 and Der p 9), but cross-reactivity between cockroach and mite serine protease is unlikely due to low amino acid identities (32-41%) among these molecules.

Group 11 Bla g 11 shares 56% sequence identity with pig α -amylase and with group 4 mite allergens Blo t 4 (50%), Der p 4 (50%) and Eur m 4 (47%). Bla g 11 seems to be an important novel allergen because the recombinant α -amylase inhibited 55% of specific IgE of German cockroach extract.⁷⁵⁷ The Per a 11 allergen has been described in China.⁷⁵⁸

Group 12 These allergens are chitinases, essential for digestion of chitin. Per a 12 and Bla g 12 have been reported in Chinese and US populations, respectively, with very different IgE prevalence (Table 24).^{758,759} Their amino acid identities with the house dust mite chitinases Der p 15 and Der f 15 are low (~35%).

Group 13 Allergens from this group are glyceraldehyde-3-phosphate dehydrogenases and have only been reported for *P. americana* as Per a 13.

4 – Sensitization to individual molecules and its clinical relevance

Cockroach allergens are strong inducers of sensitization and asthma^{760,761} and cockroach allergy is an important risk factor for emergency room visits and hospital admissions. Most characterized

allergens are from *B. germanica* and *P. americana*, although homologous from other species have been purified. Satinover S et al. found that Bla g 2 and Bla g 5 have the highest IgE prevalences among five cockroach allergens tested in US patients,⁷⁴⁶ but there are important differences in the profiles of IgE reactivity among individual patients and populations worldwide. Three recent studies in US cohorts, using a larger set of 8-10 cockroach allergens, highlight that other allergens (Bla g 3, Bla g 6, Bla g 9, Bla g 11) also show high prevalence among subjects highly sensitized to cockroach.^{754,759,762} One of the main findings from these studies is that there are no immunodominant cockroach allergens for B and T cell reactivity.

In a study performed in Taiwan to determine whether sensitization to different cockroach allergenic components correlates with different clinical manifestations and severities, eight *P. americana* allergens (Per a 1 through Per a 7 and Per a 9) were evaluated. IgE binding to Per a 2 was more frequent in patients with persistent asthma than in patients with rhinitis only, suggesting that this allergen could be a marker for more severe airway disease. Also, IgE to Per a 9 was strongly associated with rhinitis.⁷⁶³

The availability of cloned and purified allergens is allowing further investigation of their particular effects on the immune responses and the possibilities to be used as reagents for component-resolved diagnosis (CRD) and markers of severity and response to treatment. A recent study reported unique B and T cell reactivity patterns to 10 cockroach allergens per subject, without correlation with clinical phenotype/disease severity.⁷⁵⁹ The B cell reactivity to an expanded set of 8 cockroach allergens was compared in the URECA cohort between subjects with asthma and rhinitis, and subjects without these diseases. Recognition of more cockroach allergens with higher allergen-specific IgE levels was associated with asthma and rhinitis.⁷⁶²

Clinical relevance

- Cockroach allergens are strong inducers of sensitization and asthma
- Sensitization to cockroach allergens needs to be further investigated in asthmatic patients worldwide
- In some places co-exposure to cockroaches and mite allergens occurs
- CRD could help to detect genuine sensitization to mite and cockroach allergens

In the US cockroach allergy was first recognized as a risk factor for asthma in 1979 in Kansas City, MO.⁷⁶⁴ Subsequently, it became clear that this group of insects, but particularly, the German cockroach, *Blattella germanica*, was an important cause of sensitization in many large cities.⁷⁶⁵⁻⁷⁶⁷ However, even within the US there are large regional variations related to climate and housing conditions.

Notably, the large Inner City Asthma Study published in the New England Journal in 1997 found that among children cockroach allergy and exposure to cockroach allergens were more relevant for asthma morbidity than dust mite.⁷⁶⁸ On the other hand, it is important to realize that that study was largely carried out among children living in apartments in Chicago and New York, where the winters are very dry, which impairs growth of dust mites. By contrast, in most southern towns, including Atlanta, Wilmington DE, and Dallas, particularly in areas of single housing, the pattern of sensitization is consistent to both cockroach and dust mite allergens.⁷⁶⁵⁻⁷⁶⁷ A further element of this pattern was that cockroach infestation is not common in single homes, as distinct from large apartments, unless there are at least eight months of the year where these insects can live outdoors. Thus, it is easy to see why cockroach infestation of houses and sensitization of children to cockroach allergens are significant factors in towns from tropical or sub-tropical areas and completely absent in Scandinavia and rare in suburban areas of northern states in the USA and in most northern areas of Europe. In Southern China and Korea, sensitization to cockroach allergens has been reported, sometimes associated with co-sensitization to shrimp and moth.⁷⁶⁹ The important practical fact is that home interventions to reduce exposure is possible. Since mite and cockroach co-exposure is common, a differential CRD of sensitization might be necessary. In some populations (e.g., from Colombia), there is cross-reactivity between Bla g 5 and other Glutathione-transferases (GST), such as Der p 8 and or Asc I 13. In these areas, the high correlation between IgE antibodies to Bla g 5 and *Ascaris lumbricoides* GST (Asc I 13) suggests the presence of cross-reactivity between these molecules. However, the frequency of sensitization to Asc I 13 and Bla g 5 in a tropical Caribbean population is only around 23% and, in comparison to that of the mite allergen Der p 2, the strength of the IgE response to these allergens was low, which makes it difficult to assess cross-reactivity.⁷⁷⁰ By contrast, no significant cross-reactivity was found among cockroach, mite and *Ascaris* GST allergens in temperate areas of the US. This result is consistent with low amino acid sequence identity at the level of the allergen molecular surfaces, despite sharing a similar three-dimensional structure.⁷⁰⁸ The clinical importance of potential cross-sensitization between helminth and cockroach GSTs should be further investigated.

Bla g 7 and Per a 7, two of the cockroaches' tropomyosins, are pan-allergens and positive correlations between shrimp, cockroach, and dust mite IgE levels have been described. In this study, high exposure to cockroach in the home showed significant correlation to higher IgE levels to cockroach and shrimp but not to mite. Sensitization rates to tropomyosins, including the ones from mites and cockroaches, are low in the US and Europe and high in tropical countries^{771,772} more likely because of cross-reactivity with helminth tropomyosins.⁷⁷³⁻⁷⁷⁵ Arginine kinases have been described as allergens not only in seafood and other sources but also in cockroaches (Per a 9) and mites (Der p 20). Figure 63 shows predicted (thin lines) and experimentally confirmed (solid lines) cross-reactivity of *B. germanica*. Potential species-specific components are also shown (no lines).

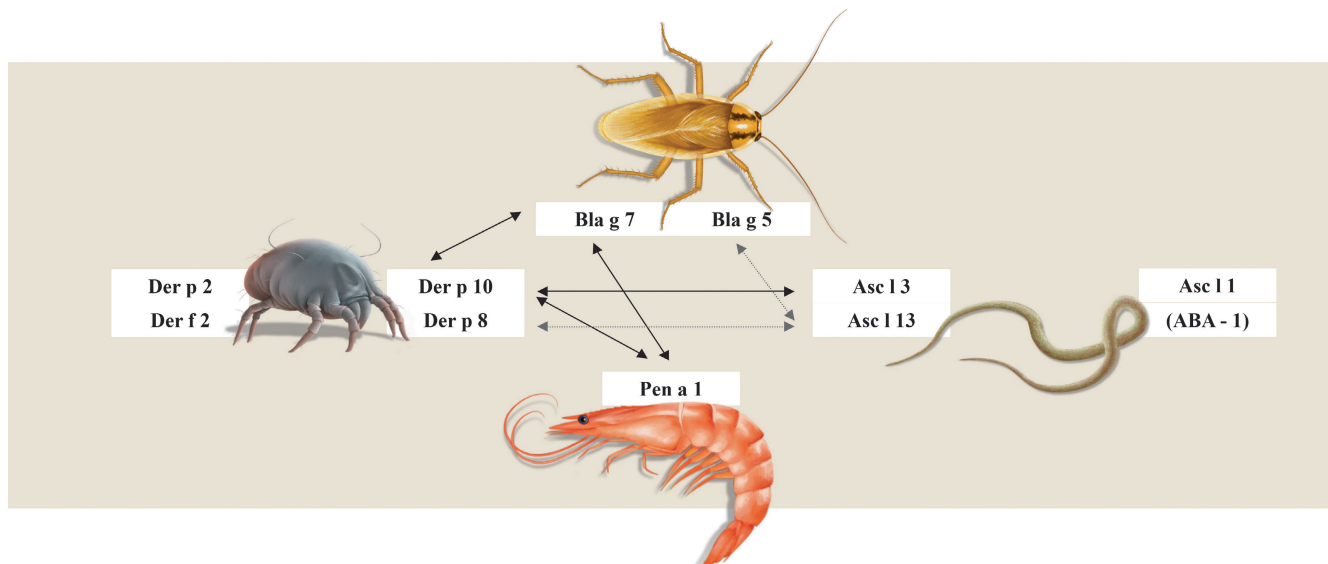


FIGURE 63 Clinically relevant cross-reactivity of cockroach allergens

5 – Clinical Management

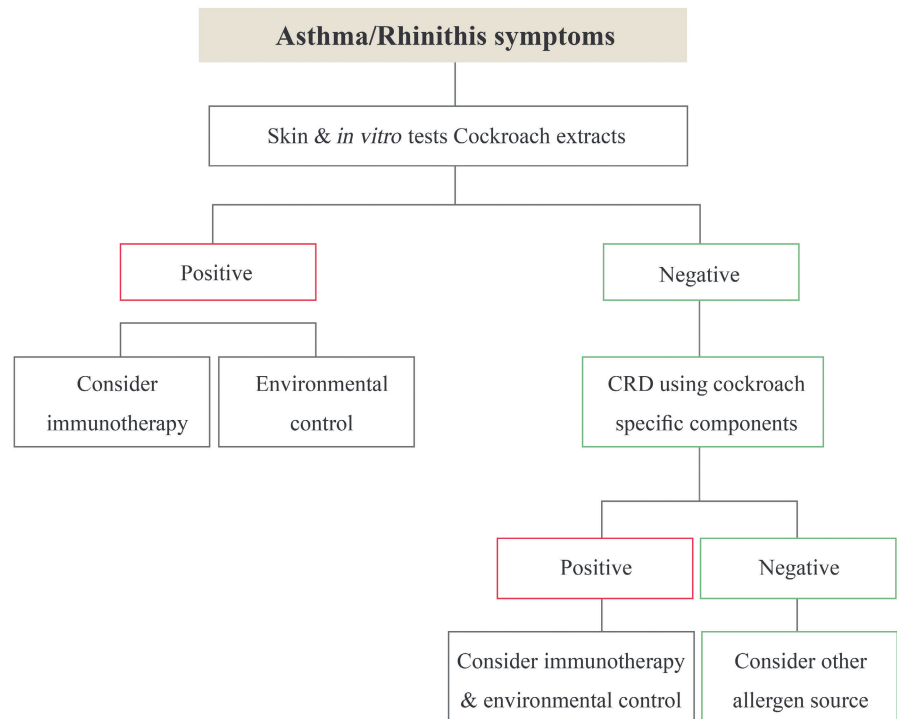
Cockroach allergy should be investigated in all patients with respiratory allergy (Figure 64). Diagnosis is performed by skin testing and/or measurement of specific IgE to cockroach, using crude extracts. However, inconsistent protein and allergen contents and relative B and T cell potencies have been reported in the commercially available cockroach extracts.^{754,776,777} To investigate the quality of commercial diagnostic skin testing extracts, Mindaye et al quantified *B. germanica* allergen levels in US extracts and compared them to what patients are exposed to in the environment. They used a multiple reaction monitoring assay involving liquid chromatography combined with mass spectrometry.⁷⁷⁷ While Bla g 1, Bla g 2, Bla g 3, Bla g 4 and Bla g 11 levels were similar in commercial extracts and environmental samples, of concern was the fact that Bla g 5, Bla g 6, Bla g 7 and Bla g 8 were readily present in the environment but largely absent in commercial diagnostic extracts. The absence of select allergens in US extracts may contribute to the skewing of cockroach sensitization profiles reported in the literature.⁷⁷⁷ *In vitro* testing for sensitization to components (CRD) is commercially available for Bla g 1, Bla g 2, Bla g 5 and Bla g 7. In contrast to allergens cross-reactive between mite and cockroach (e.g., tropomyosins), Bla g 1 and Bla g 2 are useful for detecting genuine sensitization to cockroaches in patients co-exposed to mites and cockroaches. The effectiveness of recombinant Bla g 2, Bla g 4, Bla g 5, Per a 1 and Per a 7 for skin testing was evaluated in cockroach allergic patients living in Brazil.⁷⁷² In this study, sensitization to Per a 7 was dominant with a frequency of 42% (likely due to frequent *Ascaris* infections in this area that can cause sensitization to tropomyosin), in contrast with results from other places where a heterogeneous IgE-reactivity profile among cockroach-allergic patients has been found. For example, in the US, a panel of 5 recombinant allergens (rBla g 1, rBla g 2, rBla g 4, rBla

g 5, and rPer a 7) could identify 64% of cockroach-allergic patients, and group 7 was not the dominant one as in Brazil.⁷⁴⁶ A larger battery of recombinant allergens was tested in cockroach-allergic patients in Taiwan showing that all patients reacted to at least one allergen and discovering that vitellogenin is an important allergen of *B. germanica*.⁷⁷⁸ Together, these studies suggest that a cocktail of five cockroach allergens (Bla g 1 and/or Per a 1, Bla g 2, Bla g 4, Bla g 5, Bla g 7, and/or Per a 7) would be expected to diagnose 50–64% of cockroach allergic patients worldwide. The use of an extended set of cockroach allergens (reported up to 10) can improve the diagnostic capacity of cockroach allergy.^{754,759}

Bla g 1 and Bla g 2 allergens are secreted in the digestive system and excreted in fecal particles, being good markers of cockroach allergen exposure. Threshold levels of exposure for sensitization and asthma symptoms in the susceptible population are 2 and 8 U/g of dust; however, sensitization by chronic exposure of very low levels (1 – 10 µg/g of dust) of Bla g 2 is associated with asthma and also a risk factor for wheezing in children.⁷⁷⁹ Reducing the environmental allergen exposure in homes of patients with cockroach-induced asthma, could lead to improvement of symptoms.⁷⁸⁰ However, cockroach allergens may persist for months following eradication of the insects. A controlled intervention including professional cleaning, bait traps, insecticides, and HEPA filters, decreased allergen levels, which correlated with decreased asthma symptoms, suggesting that allergen reduction is possible but difficult because continuous efforts and nonaccessible equipment might be necessary; also, the level of expertise that would be required to achieve significant cockroach extermination should be determined.

Immunotherapy (IT) is currently performed with crude extracts and there are reports supporting its effectiveness.⁷⁸¹ In a work including four pilot studies of IT with *B. germanica* extract,

FIGURE 64 Decision algorithm for cockroach allergy. Please note: No evidence-based proof of efficacy or long-term safety of cockroach. Immunotherapy in patients with asthma is available.



subcutaneous IT was more effective at modifying immune parameters than sublingual IT, although both types proved to be safe. Potential cockroach allergen immunotherapy has been tested in mouse models for prophylaxis (Bla g 2 DNA vaccine) or treatment (liposome entrapped Per a 9) of airway inflammation.⁷⁸² Currently the Inner-City Asthma Consortium is performing a subcutaneous cockroach immunotherapy trial (CRITICAL) that includes allergen B and T cell component analyses. Cockroach extracts for immunotherapy are not standardized and are highly variable in allergen content.^{754,776} Since both, the allergen content in German cockroach extracts and the sensitization profiles determine *in vitro* extract potency for IgE reactivity, the selection of appropriate extracts to be used for immunotherapy is important.⁷⁵⁴

6 – Clinical Cases

Case 1

Asthma in an African American Child in Atlanta

An eight-year-old boy presented to an emergency department (ED) of Grady Memorial Hospital with acute asthma. He responded well to treatment in the ED and was subsequently seen in clinic. Serum assays showed high total IgE and high specific IgE to both dust mite (94 kU/L) and German cockroach (65 kU/L). A subsequent home visit identified high levels of both dust mite (Der p 1 and Der p 2) and very high levels of Bla g 2 in the dust from the bedroom and the kitchen areas (see⁷⁶⁵ for methods).

Case 2

56-year-old African American Lady with Severe Atopic Dermatitis in Central Virginia

A 56-year-old lady presented to clinic in Virginia with poorly controlled AD. In the clinic she was unable to stop scratching her legs and they were severely excoriated. Her serum showed a total IgE of 3,043 kU/L and specific IgE to cockroach of 204 kU/L and to *D. pteronyssinus* of 9.4 kU/L. Furthermore, she had class 5 IgE specific for both Bla g 1 and Bla g 2. A subsequent visit to her home found extensive evidence of cockroach infestation and high levels of Bla g 2 measured by monoclonal antibody ELISA assay, on extracts of dust obtained from both bedroom and kitchen.

7 – Research and future perspectives

Clinical and basic research on cockroach allergy is expanding, giving a broader perspective of its successes and limitations. One important aspect will be the definition of the allergenic activity and clinical relevance of the individual IgE-binding molecules, including the evaluation of the statistical association of the IgE-binding frequency of each molecule between cases and controls. Besides, the detailed analyses of potential non-IgE-mediated mechanisms will bring a more balanced landscape of the clinical impact of individual allergens. This, together with the epidemiological surveys on IgE sensitization in additional developing countries will help to evaluate the need of regional arrays for CRD.

B06 – Furry animals

Marianne van Hage, Jon R Konradsen, Christiane Hilger

Highlights

- IgE to Fel d 1 is as good as IgE to cat extract for diagnosing cat allergy
- Multisensitization to dog allergen molecules is associated with dog allergy

1 – The allergen sources

Mammalian furry animals are an important source of indoor allergens.⁷⁸³ They are considered as risk factors for the development of allergic rhinitis and asthma in the domestic and occupational environment. Pets are present in up to 60% of European and US households, with cats and dogs being the most popular pets, followed by birds and small mammals. Horse riding is a favorite leisure activity for many people. Animal allergens are present in urine and saliva⁷⁸⁴ (Figure 65). They stick to animal hair and dander and are dispersed indoors. They also adhere to human clothes and are easily transported to public places. Exposure measurement studies have shown their presence in schools, day-care centres, public transport and households of nonpet owners.⁷⁸⁵

Allergic reactions have been described upon:

- Inhalation by direct contact with the animal
- Inhalation by indirect contact in a contaminated environment
- Animal bite
- Ingestion of raw or medium cooked meat

Most sensitized patients experience allergic symptoms like rhinitis or asthma upon direct exposure to the animal. As animal allergens are easily transported by human clothes, they are ubiquitous. There is evidence that exposure to cat allergens in schools may lead to asthma exacerbations in cat-sensitized students.⁷⁸⁶ In classrooms with a high number of cat-owners, allergen levels

measured are considered to be high enough to induce sensitization to cat.⁷⁸⁷ Animal bites are also capable of provoking anaphylactic reactions. Several cases of anaphylaxis upon rodent bites have been described in the literature.⁷⁸⁸ Anaphylaxis to cat, dog or horse bites does not seem common. However, anaphylaxis to bites from cat, horse, hamster, and laboratory animals have been reported in the literature.^{789–791} There is a market for “hypoallergenic pets” that are claimed to shed less allergens into their surroundings or are supposed to have genetic mutations making the responsible molecules less allergenic. However, there is no scientific evidence proving the existence of hypoallergenic dog, cat, cattle or horse breeds.^{792–794}

Serum albumins present in meat are easily inactivated by heat, but they can induce symptoms in sensitized patients upon ingestion of raw meat such as ham or sausages.⁷⁹⁵ Horse and donkey milk have been reported as allergen source upon ingestion or upon application on the skin as an ingredient of cosmetics.⁷⁹⁶

2 – The allergen families

Although a number of furry animal allergens have been described, cats and dogs are the best characterized pet animals (Table 25 and Figure 66). Lipocalins constitute the most important allergen protein family and lipocalin allergens have been isolated for each furry animal^{477,345} (Figure 67). Lipocalins are characterized by a common three-dimensional structure and a low sequence identity (see chapter C07). They are synthesized in salivary glands and are dispersed into the environment by saliva and dander. Serum albumins are highly cross-reactive molecules generally considered as minor allergens (see chapter C04). They are abundant in saliva and dander. Fel d 1, the major cat allergen, is a secretoglobin expressed in salivary glands and skin. Two allergens that are members of the latherin protein family are known to have surfactant properties, Equ c 4 and Fel d 8. Can f 5, a prostatic kallikrein was isolated from urine of male dogs. Fel d 3 and Can f 8 belong to the cystatin A protein family. These allergens were isolated from skin and are detected in dander. The lysozymes Equ c 6 and Equ a 6 were identified as allergens in donkey and horse milk. Recently, Niemann pick type C (NPC2) proteins have been identified in both cat and dog.^{257,797}

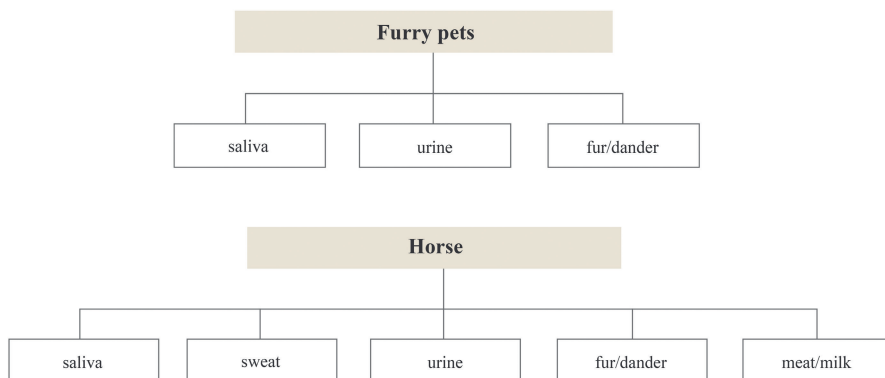


FIGURE 65 Animal allergen sources

TABLE 25 Allergenic molecules from furry animals

Allergen source	Allergen	Biochemical name	Prevalence of allergen-specific IgE among patients (%)	MW (kDa)
Domestic cattle <i>Bos taurus</i>	Bos d 2	lipocalin	>90- (of cow allergic patients)	20
	Bos d 3	S100 calcium-binding protein A7	Single cases	11
	Bos d 4	alpha-lactalbumin	>90 (of cow milk allergic patients)	14.2
	Bos d 5	beta-lactoglobulin	>90 (of cow milk allergic patients)	18.3
	Bos d 6	serum albumin	>90 (of cow milk allergic patients)	67
	Bos d 7	immunoglobulin	IgE reactivity not reported in allergen.org	160
	Bos d 8-12	caseins	63 (of milk-allergic children had IgE to Bos d 8)	19-30
	Bos d 13	myosin light chain	27 (of beef allergic patients)	21
Dog <i>Canis familiaris</i>	Can f 1	lipocalin	50-90	23-25
	Can f 2	lipocalin	22-35	19
	Can f 3	serum albumin	25-60	69
	Can f 4	lipocalin	35-59	18
	Can f 5	kallikrein	31-76	8
	Can f 6	lipocalin	56	27-29
	Can f 7	Niemann Pick type C2	10-20	14
	Can f 8	cystatin	10-14	14
Guinea-pig <i>Cavia porcellus</i>	Cav p 1	lipocalin	83	20
	Cav p 2	lipocalin	62	17
	Cav p 3	lipocalin	45	18
	Cav p 4	serum albumin	41	66
	Cav p 6	lipocalin	59	18
Donkey <i>Equus asinus</i>	Equ a 6	lysozyme	single cases	15
Domestic horse <i>Equus caballus</i>	Equ c 1	lipocalin	76-100	25
	Equ c 2	lipocalin	33-62	17
	Equ c 3	serum albumin	50	67
	Equ c 4	latherin	77-100	17, 20.5
	Equ c 6	lysozyme	single cases	15
Domestic cat <i>Felis domesticus</i>	Fel d 1	secretoglobin	>90	18
	Fel d 2	serum albumin	14-23	69
	Fel d 3	cystatin-A	10	11
	Fel d 4	lipocalin	63	22
	Fel d 5	immunoglobulin A	20-40	400
	Fel d 6	immunoglobulin M	not reported in allergen.org	800-1000
	Fel d 7	lipocalin	38	17.5
	Fel d 8	latherin	19	24
Golden hamster <i>Mesocricetus auratus</i>	Mes a 1	lipocalin	single cases	20.5, 24, 30
House mouse <i>Mus musculus</i>	Mus m 1	lipocalin	>90	17
Rabbit <i>Oryctolagus cuniculus</i>	Ory c 1	lipocalin	>90	17-18
	Ory c 2	lipocalin	75	22
	Ory c 3	secretoglobin	77	19-21
	Ory c 4	lipocalin	46	24
Siberian hamster <i>Phodopus sungorus</i>	Phod s 1	lipocalin	>90	23
Rat <i>Rattus norvegicus</i>	Rat n 1	lipocalin	>90	17
Domestic pig <i>Sus scrofa</i>	Sus s 1	serum albumin	single cases of cat allergic individuals	60

Molecular weight (MW) is as stated on WHO/IUIS Allergen Nomenclature Sub-Committee Website, unless otherwise referenced. Prevalences are from www.allergen.org, reference 803 and Florin-Dan P et al. World J Methodol. 2021;11:46-60 and Torres JA et al. J Biol Chem. 2014;289(34):23382-8.

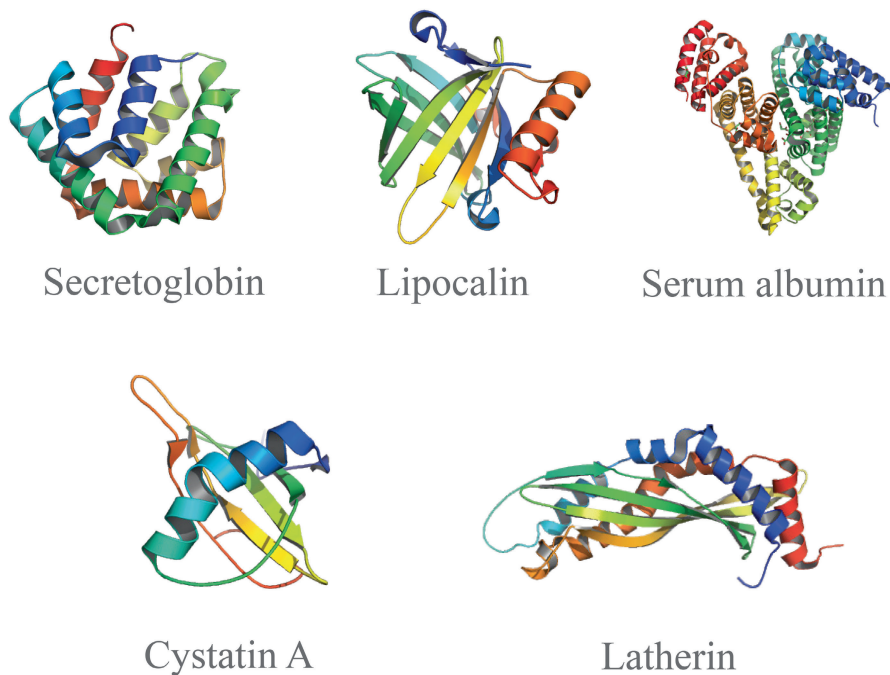


FIGURE 66 Molecular structures of animal allergens. The secretoglobin family is represented by Fel d 1 (1ZKR), lipocalins by Equ c 1 (1EW3), serum albumins by Equ c 3 (4F5U), cystatins by human cystatin A (1GD3) and latherins by Equ c 4 (3ZPM). In parentheses, ID numbers of the crystal structures are accessible in the PDB databank <https://www.rcsb.org>

3 – Epidemiology and geographical variation of allergenic molecules

Large epidemiology studies are based on skin prick test results and determination of specific IgE to animal dander. These studies are hampered by the fact that cross-reactive molecules such as serum albumins are present in the extracts used and this may lead to an overestimation of sensitization rates to a particular animal. Furthermore, commercial skin prick test extracts for, e.g., dog allergy diagnosis have shown extensive variation in allergen composition.²⁶¹

A survey of almost 13,000 German children and adolescents reported sensitization rates of 9.7% to dog, 8.1% to cat and 4.4% to horse dander.⁷⁹⁸ Interestingly, animal sensitization prevalence raised from 5.7% in the age group 3-6 years to 17.2% in the 14-17 years old adolescents. The Swedish BAMSE study, which is an unselected population-based birth cohort of more than 4000 children, lately reported a similar increase from 4 to 24 years, reaching 19.6% to cat, 16.9% to dog and 9.8% to horse in young adulthood.⁷⁹⁹ Furthermore, an increase in sensitization to furry animals has also been reported among adults in two population based studies measured 15 years apart, where sensitization to cat increased from 16% to 26% and to dog from 13% to 25%.⁸⁰⁰ The GA²LEN skin test study has revealed striking geographic sensitization pattern among 14 European countries.⁸⁰¹ Among patients presenting at allergy centres with suspected allergic reaction to inhalant allergens, prevalence to cats and dogs was highest in Denmark and lowest in Austria. sensitization to animals tended to be higher in Nordic countries, which probably depends on the fact that, e.g., cats are kept indoors in a higher frequency in the Northern part of Europe. Moreover, as much as 26% of European adults coming to the clinic for suspected allergy to inhalant allergens are sensitized to cat and 27% to dog.⁸⁰²

4 – Sensitization to individual molecules and their clinical relevance

A number of furry animal components are now available and their clinical value has been addressed in several studies.⁸⁰³ IgE to the major cat allergen Fel d 1 has shown to be as good as IgE to cat extract for diagnosing cat allergy.⁸⁰⁴ Moreover, children with asthma due to cat have also been reported to have higher IgE antibody levels to Fel d 1 compared to children with rhinoconjunctivitis.⁸⁰⁴

Fel d 1 has likewise been reported to be the most common sensitizing cat component (8.9%) in an adult population.⁸⁰⁵ In a study among Swedish schoolchildren current asthma and asthma symptoms following contact with cats were associated with co-sensitization to the cat lipocalin Fel d 4.⁸⁰⁶ Furthermore, sensitization to Fel d 4 and Fel d 2 has shown to be independently related to type-2 inflammation among young patients with asthma.⁸⁰⁷ In a longitudinal study, adults sensitized to at least one cat component (Fel d 1, Fel d 2 or Fel d 4), in addition to cat extract, had more bronchial hyperresponsiveness, higher fractional exhaled nitric oxide (FeNO) and were more likely to develop rhinitis and asthma compared to those sensitized to cat extract only.⁸⁰⁸ Moreover, IgE to Fel d 4 and Fel d 2 have also been associated with atopic dermatitis in children with cat allergy⁸⁰⁹ [32] and a single case of a cat-induced anaphylactic reaction in a child sensitized exclusively to Fel d 1 has been reported.⁸¹⁰

Molecular allergy diagnostics has shown to refine characterization of children sensitized dog dander. So far 6 dog allergen molecules (Can f 1 – Can f 6) are available for dog allergy diagnosis. Most children sensitized to dog are sensitized to more than one component, and co-sensitization to Can f 5 and Can f 1 or Can f 2 has shown to be related with asthma.⁸⁰⁶ Käck U et al. found a

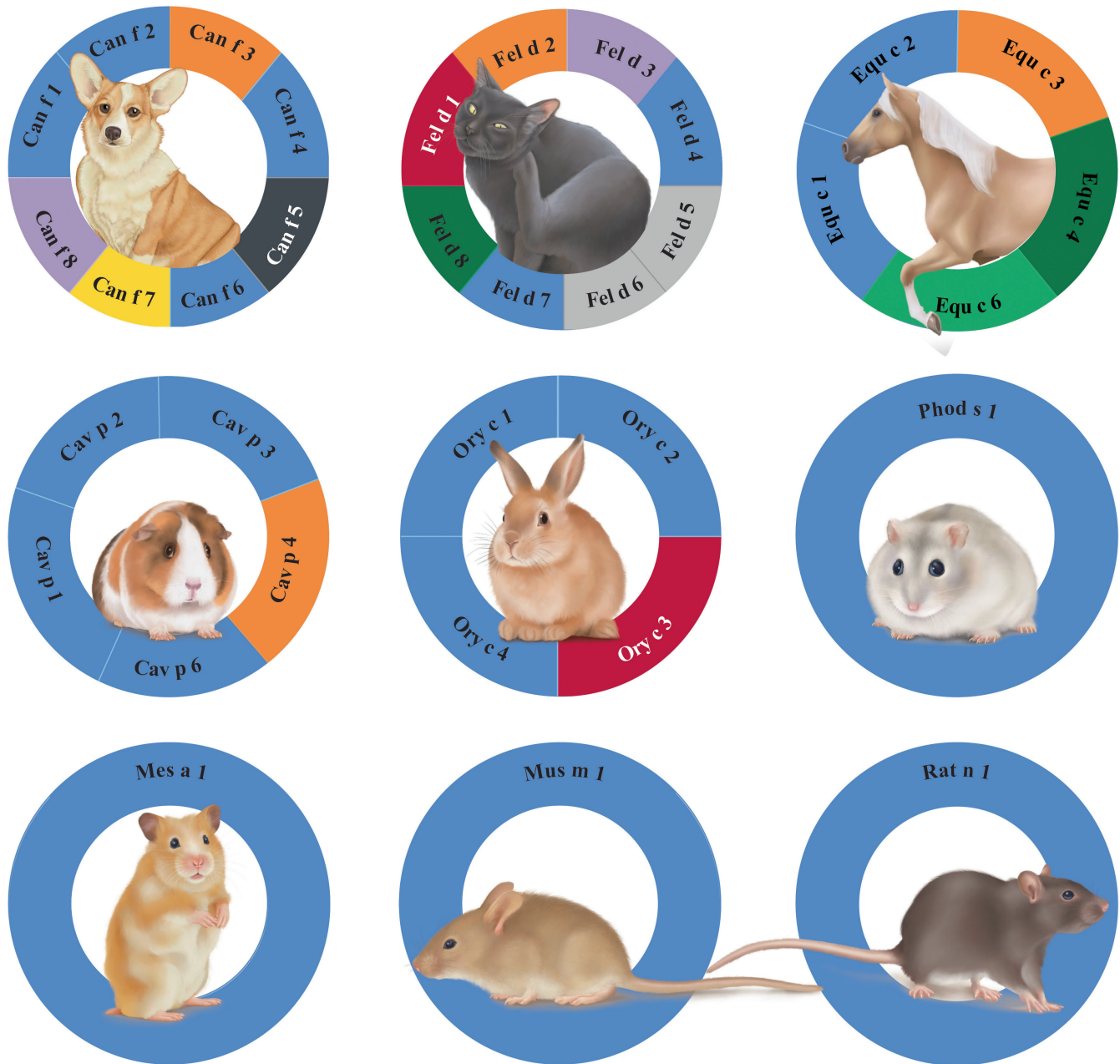


FIGURE 67 Known allergens of furry animals, as listed in the database of the WHO/IUIS Allergen Nomenclature Sub-Committee (www.allergen.org). Proteins belonging to the lipocalin family are depicted in blue, serum albumins are shown in orange, latherins in dark green, immunoglobulins in light grey, cystatin in purple, secretoglobins in dark red, NPC2 in light orange, kallikrein in dark grey, and lysozyme in light green.

significant association between sensitization to the lipocalins Can f 4 and Can f 6 as well as with an increasing number of sensitizing allergen components and clinical symptoms of dog allergy in children evaluated by nasal provocation with dog dander extract.⁸¹¹ Furthermore, multi-sensitization to allergens from furry animals and high IgE levels to dog lipocalins were associated with asthma and asthma severity.¹⁶³⁸ However, monosensitization to the male dog allergen Can f 5 has been related to a negative nasal challenge.⁸¹¹ As Can f 5 is a kallikrein, monosensitization to this allergen has shown to be highly specific for sensitization to male dogs.⁸¹² Recently Schoos et al, showed that patients allergic to dog

and monosensitized to Can f 5 tolerated a conjunctival challenge with female dog extract but not with male dog extract.⁸¹³ Can f 5 has been reported to be the most common sensitizing dog component (3.6%) in an adult population.⁸⁰⁵ Up to 76% of patients with horse allergy are sensitized to Equ c 1.⁸¹⁴ In an adult Swedish population, sensitization to Equ c 1 was present in 2% and in 12% among patients with asthma.⁸⁰⁵

Using an allergen chip (MeDALL chip) containing several individual pet allergens, sera from nearly 800 randomly collected children from the BAMSE birth cohort at 4, 8 and 16 years were analyzed in relation to symptoms to these animals up to 16 yrs. The

authors reported that IgE to Fel d 1 and Can f 1 in childhood are predictive markers of allergy to cat or dog, respectively, at 16 years. Furthermore, IgE to Can f 1 was the most important prognostic marker of dog allergy and superior to IgE to dog allergen extract. IgE to Can f 5 is to a lower extent associated with allergy to dog than IgE to Can f 1.³¹²

Sensitization to lipocalins, which are predominantly derived from furry animals, has been associated with asthma in children⁸¹⁵ and multiple sensitization towards lipocalins, kallikrein and secretoglobulin components with increased bronchial inflammation in severe asthmatics.⁸¹⁶ In addition, in children with severe asthma and allergy towards furry animals, sensitization to Can f 2 (22% vs. 0%, $p = 0.009$) and Equ c 1 (51% vs. 25%, $p = 0.03$) was shown to be more common than in children with controlled asthma.⁸¹⁷ Furthermore, in adults, sensitization to Fel d 1, Can f 1, Can f 2 and Can f 3 and polysensitization (sensitization to more than 2 components) was associated with rhinitis, asthma and asthma severity and related with increased FeNO and eosinophil levels.⁸¹⁸

Although a number of small furry animal allergens have been isolated, there are no epidemiological studies nor studies on the clinical relevance of single components.

With respect to allergen-specific IgG and IgG4, Käck et al. found no significant differences in IgG- or IgG4 levels to dog dander or to any dog allergen molecule between dog dander sensitized children with a positive and a negative provocation test with dog dander extract.²⁶² They concluded that the responses rather reflected exposure than tolerance to dog, in line with the study by Burnett and colleagues.⁸¹⁹

Epidemiological studies have shown that the presence of animal allergens in the indoor environment has been associated with an increased risk of developing allergic symptoms. Monitoring of allergen contamination allows to determine allergen levels and to assess eviction strategies. Methods of dust collection and antibody-based allergen quantification assays allow to measure allergen levels of Fel d 1, Fel d 4, Can f 1, Equ c 1, Mus m 1, Ory c 3, Cav p 1 and Rat n 1 in settled dust, but not all are commercially available.⁸²⁰

5 – Clinical management

Exposure to furry animals can lead to different sensitization patterns with different clinical implications. A careful record of the clinical history such as the presence of pets at home or regular pet contact is of great value. Skin prick test or allergen-specific IgE using extracts from furry animals will confirm sensitization. In this context the dose of exposure is also of importance. As furry animals contain cross-reactive molecules such as serum albumins, some of the cross-reactive lipocalins and potentially other cross-reactive molecules, it is important to define the primary allergenic source, especially if a specific immunotherapy is intended. Co-sensitization has to be distinguished from cross-sensitization. It is important to acknowledge that IgE-cross-reactivity may not always imply clinical cross-reactivity. If the cross-reactive IgE is against allergens with low to

moderate degree of sequence homology, which is the case for many of the lipocalins, the patient may not experience symptoms to these allergen sources. However, if the cross-reacting lipocalin allergens have high sequence homology, patients may experience symptoms to all these allergen sources. Moreover, there are few data on symptoms clearly related to cross-reactive molecules as monosensitization to these components seems to be rare.

Taken together: Fel d 1, Fel d 2, Fel d 4, Fel d 7 and, Can f 1 to Can f 6 are commercially available markers of cat and dog sensitization. Equ c 1 may cross-react with Fel d 4 and Can f 6.⁸²¹ The coverage is rather good for cat and dog, but only two cross-reactive molecules, Equ c 1 and Equ c 3, are available for horse and some molecules are available for component-resolved diagnosis of small furry pets. Cav p 1 and Ory c 3 are specific markers of allergy to guinea-pig and rabbit.^{822,823} Mes a 1 and Phod s 1 are marker allergens of the golden and dwarf hamster, respectively.⁴⁷⁷ Not all components, however, are available on all platforms.

Sensitization to major cat/dog/horse allergens (e.g., Fel d 1 / Can f 1, Can f 5/Equ c 1) are specific markers of cat/dog/ horse sensitization. Sensitized patients may experience symptoms from the upper and/or lower airways to cat/ dog/horse. IgE to Fel d 1 and Can f 1 in childhood have shown to be predictive markers of cat or dog allergy in adolescence.³¹² In patients with suspected horse allergy, only sensitization to Equ c 1 had been found to be clinically relevant.⁸¹⁶ Some lipocalins (Can f 6, Fel d 4, Equ c 1; Fel d 7 and Can f 1) share a high sequence identity and are markers of cross-sensitization (Table 26). As Can f 1 is also a primary marker of dog allergy, the decision algorithms in chapter C07 may be helpful. See also Figure 68 for clinical algorithm. The newly identified cat allergen, NPC2, has shown to have high cross-reactivity to Can f 7.²⁵⁷

Cross-reactive animal allergens with high sequence homology are, e.g., serum albumins. Serum albumins are involved in pork-cat syndrome, where sensitization to cat serum albumin represents the primary event in the development of cross-reactive IgE.⁷⁹⁵ For further information, please see chapter C04 on Serum albumins.

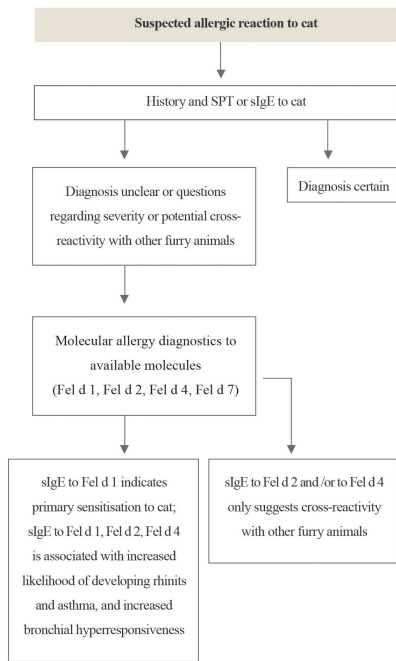
Other domestic animals

Bovine allergens are important inducers of occupational allergic airway diseases in cattle-exposed farmers. The European Farmers' Project Study Group has determined that the prevalence of work-related respiratory symptoms was 21.8% among cattle farmers. The

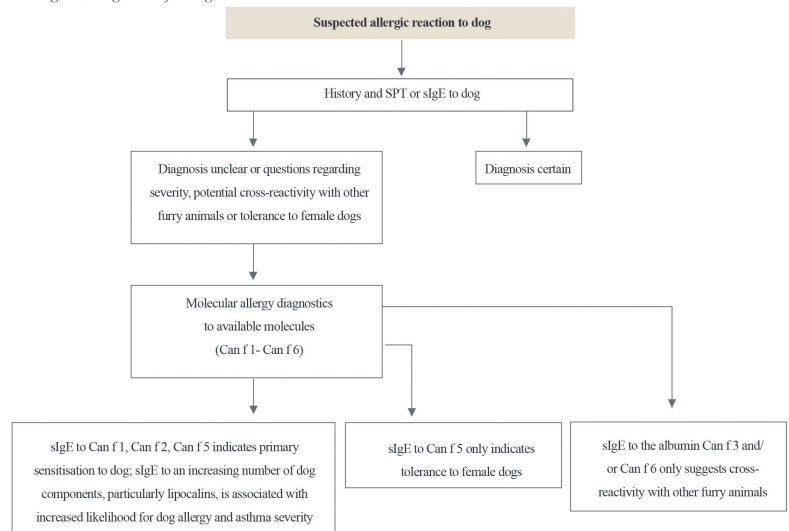
TABLE 26 Cross-reactive allergen from furry animals

Allergen	Degree of cross-reactivity
Can f 1, Fel d 7	moderate risk of cross-reactivity
Can f 3, Fel d 2, Equ c 3, Sus s 1	high risk of cross-reactivity with other serum albumins
Can f 6, Fel d 4, Equ c 1, Cav p 6, Mus m 1	moderate risk of cross-reactivity with some lipocalins
Can f 8, Fel d 3	moderate risk of cross-reactivity
Equ c 6, Equ a 6	high risk of cross-reactivity

1. Diagnostic algorithm for cat.



2. Diagnostic algorithm for dog.



3. Diagnostic algorithm for horse.

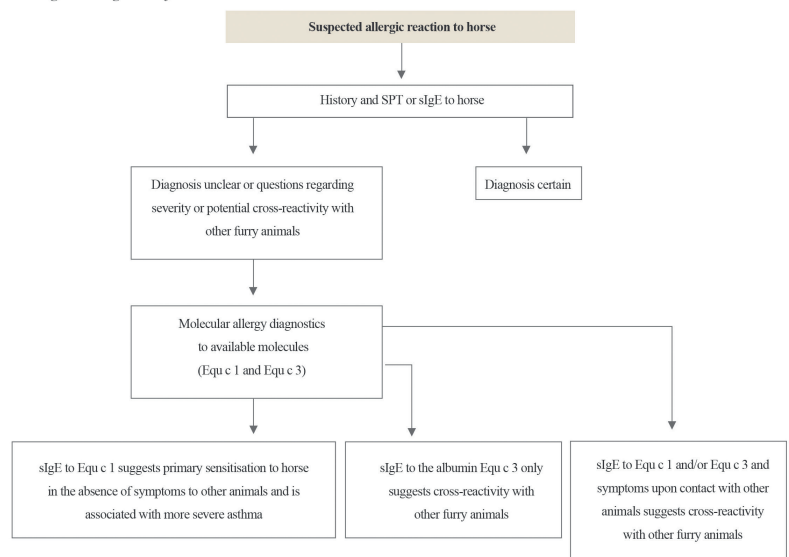


FIGURE 68 Diagnostic algorithms for cat, dog, and horse allergy

main sources of bovine allergens are cow hair and dander, but allergens are also found in urine, saliva, milk, and beef. Early investigations of bovine dander extracts have identified 17 different antigenic components. Three of these, having molecular weights of 24, 22 and 20 kDa, have been characterized as major allergens. Subsequent studies have shown that the 20-kDa protein, designated as Bos d 2, is the most important allergen in cow allergen extracts and belongs to the lipocalin family of proteins (see chapter C07). ELISA are available to quantify Bos d 2 or cow hair proteins⁸²⁴ in the air and dust samples to monitor the allergen load in occupational and home environment.

Clinical diagnosis

1. Skin prick test (SPT):

Commercial cat extract can be used, but dog extract has shown marked variations between companies in their content of major dog

allergens.²⁶¹ There are no data available on the usefulness of horse extract.

2. IgE-Testing:

Total IgE has no added value in this context. Testing of single components will allow to determine the primary sensitization source (Figure 68). Different sensitization patterns are discussed in the chapters C07 on Lipocalins and C04 Serum albumins.

3. Challenge tests

Nasal provocation testing using natural extracts is feasible in complicated cases and this option may be particularly relevant in patients sensitized to several dog allergen molecules⁸¹¹. Challenge tests using natural cat extracts are usually not needed but may be indicated in selected cases such as polysensitization or when discordances are observed between skin tests and IgE results. Challenge tests using a cat challenge chamber are only performed in clinical

trials to evaluate efficacy of new molecules used for immunotherapy or pharmacological treatment.

4. Advices and avoidance

A - If the patient experiences asthma symptoms at exposure to dog or cat even after proper medication the patient should be informed that such direct and continuous exposure may have detrimental effects on health.

B - If the patient experiences asthma at indirect exposure to cat or dog despite symptomatic treatment, allergen-specific immunotherapy is recommended.

5. Pharmacotherapy

Symptomatic treatment as required.

6. Allergen-specific immunotherapy (AIT)

Allergen-specific immunotherapy with extracts from cat yield better clinical results than those from dog. The higher complexity of dog allergy sensitization patterns, the lack of preparations with an adequate balance of major allergens is likely to explain this divergence.^{261,825,826} AIT for cat or dog is recommended if the patient experiences asthma at indirect exposure to cat or dog despite symptomatic treatment.

6 – Clinical cases

Case 1 (original): Dog allergy

Clinical history: A 17 year-old-boy, diagnosed with asthma, and symptoms triggered following exposure to some but not all dogs. He had no symptoms of rhinitis.

Test with extract: Specific IgE to dog dander was positive (12 kU/L).

Test with molecules: Specific IgE was analysed against Can f 1-6 and only IgE to Can f 5 was positive (7.0 kU/L).

Nasal challenge with dog dander extract: The patient did not develop symptoms.

Conclusion: As the patients was IgE positive to the male kallikrein Can f 5, it may be possible that the patient tolerates female dogs but develop symptoms upon exposure to male dogs.

Case 2 (original): Dog allergy

Clinical history: A 16 year-old-boy, diagnosed with rhinitis and asthma. He develops symptoms of rhinitis but no symptoms of asthma upon exposure to dog. His family wants to get a dog.

Test with extract: Specific IgE to dog dander was positive (9 kU/L).

Test with molecules: Specific IgE was analysed against Can f 1-6 and was positive to Can f 1 (5.3 kU/L), Can f 4 (0.5 kU/L) and Can f 6 (0.8 kU/L).

Nasal challenge with dog dander extract: The patient developed symptoms.

Conclusion: As the patient is sensitized to three dog allergens his asthma will probably worsen if the family gets a dog.

Case 3 (theoretical): Cat allergy

Clinical history: A female, 25 years old, experiencing asthma symptoms to cat at indirect exposure, e.g., when travelling by public transport or visiting public places. The patient is investigated for AIT against cat.

Test with extract: Specific IgE to cat dander was positive (15 kU/L).

Test with molecules: Specific IgE was analysed against Fel d 1, Fel d 2, Fel d 4 and Fel d 7 and only IgE to Fel d 1 (12 kU/L) was positive.

Conclusion: As the patient is sensitized to Fel d 1, which is the major allergen in cat extract, she will most likely benefit from AIT with cat extract.

7 – Research and future perspectives

Molecular allergy testing in furry animal allergy is still to be considered as a complement to extract based testing. More knowledge regarding sensitization patterns associated with severe respiratory symptoms and the impact of polysensitization are needed. With respect to treatment, sensitization profiles that are likely to be associated with a positive outcome of AIT are lacking. Furthermore, studies revealing whether molecular allergy testing can be used to monitor the effect of AIT are required. This issue is further complicated by the fact that allergen extracts used for AIT vary in their content of allergens and more clinical studies are needed for evaluating AIT to dog and horse. AIT for small furry animals is still lacking.

The most important allergen molecules from furry animals are available and they may have a role in improving AIT for furry animal allergy by developing patient-tailored treatment. A vision would be to aim for mixtures of allergen molecules matching the patients' profiles. However, clinical studies testing whether AIT with furry allergen molecules will improve symptoms, efficacy, safety and quality of life are warranted.

A new approach for treating allergy to furry animals is to reduce the secretion of immunologically active allergens from the pet. This was demonstrated for Fel d 1 in a study by Satyaraj et al.⁸²⁷ where introduction of anti-Fel d 1 immunoglobulin Y in cat food reduced secretion of the immunologically active Fel d 1 and lowered Fel d 1 levels in the environment.

B07 – Allergy to moulds

Sabine Kespohl and Monika Raulf

Highlights

- Of the huge variety of moulds worldwide, only few species can be tested.
- The mould species with greatest clinical relevance are: *Alternaria alternata* and *Cladosporium herbarum* (outdoor); *Aspergillus fumigatus* and *Penicillium chrysogenum* (indoor).
- Moulds are ubiquitous, but in contrast to spores in the air, the sensitization rate to mould is relatively low.
- Guidelines recommended diagnostic tools are skin prick tests and serological IgE measurement.
- A mould mix may be recommended as serological screening tool.
- Component-resolved mould allergen diagnosis is available for Alt a 1, Alt a 6, Cla h 8, Asp f 1 - 4 and Asp f 6.
- Component-resolved diagnosis is useful to verify allergic bronchopulmonary aspergillosis (ABPA) and also for patients sensitized to *Alternaria alternata* before starting specific immunotherapy (SIT).

1 – The source

The predicted number of fungal species varies from 0.6 – 1 million worldwide.⁸²⁸ In principle, IgE-mediated sensitization can occur against any fungal species. Fungi reproduce by spores, which are airborne spreading units, usually between 2 and 100 µm in diameter, which is small enough to infiltrate lungs and alveoli. The concentration of spores in the air depends on the temperature and humidity. The highest concentration of mould spores in outdoor air occurs in northern Europe from June to October and in southern Europe from May to August.⁸²⁹ But climate changes can increase total atmospheric mould by mean of longer spore season with possibly quantitatively higher spore releases. Furthermore, extreme weather conditions such as frequent storms, extreme rainfalls and increased flooding in many areas of the world contribute to the increased growth and spread of moulds and spores. This applies both to outdoor mould, which often gets into indoor areas due to strong winds, and to the problem of prolonged dampness in buildings due to water damage, resulting in significantly increased occurrence of indoor mould.⁸³⁰ Besides spores, fragments of mycelial filaments (0.2 - 10 µm) are also airborne allergen carriers and can occur in even greater amounts than spores. In real life

patients are exposed to both spores and hyphae. Several studies have shown that spores and hyphal fragments are liberated from natural occurring mould cultures and became airborne.⁸³¹ It was shown that particular mould allergens, Asp f 1⁸³² and Alt a 1 were detected in spores.^{833,834} But other allergens like Alt a 8, a mannitol dehydrogenase, were exclusively localized in vacuole-like compartments of the hyphae.⁸³⁴ Fungal source material, used for preparation of diagnostic test solution, e.g., for skin prick tests, was shown to consist of a spore and hyphal material mixture.

According to medical mycology, fungi are divided into: dermatophytes, yeasts and moulds. Dermatophytes, which cause dermatophytosis on the horny layer of the skin, hair and nails. Unlike other skin fungi, they can feed on keratin (keratinase). Yeasts, on the other hand, are unicellular, spherical fungi that reproduce by budding. The most common diseases are candidiasis (*Candida* species) or infections / type IV allergy of the skin caused by *Malassezia*. By contrast, moulds often trigger respiratory problems in the form of an allergic type I (IgE-mediated) immune reaction, or an allergic type III / IV reaction as hypersensitivity pneumonitis. In immuno-compromised individuals, moulds, especially thermotolerant species such as *Aspergillus fumigatus*, can also grow in the lungs (mycosis / aspergillosis). The rate of sensitization to moulds in the general population is below 5%, which is significantly lower compared to those of other environmental allergens like pollen, animal allergens or mites shown in Table 27. Sensitization to fungi is more common when individuals already have allergic sensitization or suffer from asthma. In particular, *Aspergillus fumigatus* seemed to be important in patients with severe asthma with fungal sensitization (SAFS).⁸³⁵

2 – Allergen families and allergic molecules

Altogether, there are currently 113 fungal allergens listed in the official WHO/IUIS database allergens originating from 30 fungal species (www.allergen.org; 10/2021). From these 106 allergens could be found in 42 allergen families. The AllFam database of allergen families (<http://www.meduniwien.ac.at/allfam/>) summarizes common phylogenetic, structural and functional properties of allergens. In the following table fungal allergens are grouped according to their biological function, molecular weight, way of exposure, sensitization rates of single allergens. sensitization rates have been summarized as minor allergen (<50% sensitization in study group) or major allergens (>50% sensitization in study group) (Table 28) modified and updated from⁸³⁶.

TABLE 27 Prevalence of mould sensitization among different population groups (modified from⁸³⁶)

Moulds	General population	Patient group with allergic symptoms	Asthmatic group
<i>Alternaria</i>	3-4% ¹²³¹ ; 5% ¹⁶²⁴	8-10% ⁸⁰¹ ; 3% ¹⁶²⁷ ; 9-12% ¹⁶²⁶	22% ⁸³⁵ ; 6% ¹⁶²⁷
<i>Aspergillus</i>	2-3% ¹²³¹ ; 3% ¹⁶²⁴	4-5% ⁸⁰¹ ; 3% ¹⁶²⁷ ; 7-10% ¹⁶²⁶	45% ⁸³⁵ ; 11% ¹⁶²⁷
<i>Cladosporium</i>	1-2% ¹²³¹ ; 2% ¹⁶²⁴ ;	4-6% ⁸⁰¹ ; 2% ¹⁶²⁷ ; 8-10% ¹⁶²⁶	24% ⁸³⁵ ; 4% ¹⁶²⁷
<i>Penicillium</i>	5% ¹⁶²⁴ ; 8% ¹⁶²⁵	13-29% ¹⁶²⁶	29% ⁸³⁵

TABLE 28 Major and minor relevant allergen molecules from fungi

Species	Medical mycology	Allergen	Type of protein	MW (SDS-PAGE)	Exposure	Classified as
Proteases (Serin proteases*) n=24						
<i>Alternaria alternata</i>	Mould	Alt a 15	Serine protease	58 kDa	Airway	Minor allergen
<i>Aspergillus flavus</i>	Mould	Asp fl 13	Alkaline serine protease	34 kDa	Airway	Major allergen
<i>Aspergillus fumigatus</i>	Mould	Asp f 5	Metallo protease	40 kDa	Airway	Major allergen (ABPA)
		Asp f 10	Aspartate protease	34 kDa	Airway	Minor allergen (ABPA)
		Asp f 13	Alkaline serine protease	34 kDa	Airway	-
		Asp f 18	Vacuolar serine protease	34 kDa	Airway	Major allergen (asthma)
<i>Aspergillus niger</i>	Mould	Asp n 18	Vacuolar serine protease	34 kDa	Airway	-
<i>Aspergillus oryzae</i>	Mould	Asp o 13	Alkaline serine protease	34 kDa	Airway	Major allergen (asthma)
<i>Aspergillus versicolor</i>	Mould	Asp v 13	Extracellular alkaline serine protease	43 kDa	Airway	Minor allergen
<i>Cladosporium cladosporioides</i>	Mould	Cla c 9	Vacuolar serine protease	36 kDa	Airway	Major allergen
<i>Cladosporium herbarum</i>	Mould	Cla h 9	Vacuolar serine protease	45 kDa	Airway	Minor allergen
<i>Curvularia lunata</i>	Mould	Cur l 1	Serine protease	31 kDa	Airway	Major allergen
		Cur l 4	Subtilisin like serine protease	54 kDa	Airway	Major allergen
<i>Epicoccum purpurascens</i>	Mould	Epi p 1	Serine protease	30 kDa	Airway	Minor allergen
<i>Fusarium proliferatum</i>	Mould	Fus p 9	Vacuolar serine protease	36.5 kDa	Airway	Major allergen
<i>Penicillium brevicompactum</i>	Mould	Pen b 13	Alkaline serine protease	33 kDa	Airway	Major allergen (asthma)
<i>Penicillium chrysogenum</i>	Mould	Pen ch 13	Alkaline serine protease	34 kDa	Airway	Major allergen (asthma)
		Pen ch 18	Vacuolar serine protease	32 kDa	Airway	Major allergen (asthma)
<i>Penicillium citrinum</i>	Mould	Pen c 13	Alkaline serine protease	33 kDa	Airway	-
<i>Penicillium oxalicum</i>	Mould	Pen o 18	Vacuolar serine protease	34 kDa	Airway	Major allergen (asthma)
<i>Rhodotorula mucilaginosa</i>	Yeast	Rho m 2	vacuolar serine protease	31 kDa	Airway	Major allergen
<i>Trichophyton rubrum</i>	Dermatophyt	Tri r 2	Putative secreted alkaline protease Alp1	29 kDa	Contact	Minor allergen
		Tri r 4	Serine protease	85 kDa	Contact	-
<i>Trichophyton tonsurans</i>	Dermatophyt	Tri t 4	Serine protease	83 kDa	Contact	Major allergen
Ribosomal proteins (P1* and P2*) n=9						
<i>Alternaria alternata</i>	Mould	Alt a 5	Ribosomal protein P2	11 kDa	Airway	Minor allergen
		Alt a 12	Acid ribosomal protein P1	11 kDa	Airway	-
<i>Aspergillus fumigatus</i>	Mould	Asp f 8	Ribosomal protein P2	11 kDa	Airway	-
		Asp f 23	L3 ribosomal protein	44 kDa	Airway	-
<i>Cladosporium herbarum</i>	Mould	Cla h 5	Acid ribosomal protein P2	11 kDa	Airway	Minor allergen
		Cla h 12	Acid ribosomal protein P1	11 kDa	Airway	-
<i>Fusarium culmorum</i>	Mould	Fus c 1	Ribosomal protein P2	11 kDa	Airway	Minor allergen
<i>Penicillium brevicompactum</i>	Mould	Pen b 26	Acidic ribosomal prot. P1	11 kDa	Airway	-
<i>Penicillium crustosum</i>	Mould	Pen cr 26	60S acidic ribosomal phosphoprotein P11	1 kDa	Airway	Minor allergen
Isomerases (Cyclophilins*) n=6						
<i>Aspergillus fumigatus</i>	Mould	Asp f 11	Peptidyl-prolyl cis-trans isomerase (Cyclophilin)	24 kDa	Airway	Major allergen
		Asp f 27	Peptidyl-prolyl cis-trans isomerase (Cyclophilin)	18 kDa	Airway	Major allergen
<i>Aspergillus terreus</i>	Mould	Asp t 36	Triosephosphate isomerase (TIM)	28 kDa	Airway	Minor allergen
<i>Malassezia sympodialis</i>	Dermatophyt	Mala s 6	Peptidyl-prolyl cis-trans isomerase (Cyclophilin)	17 kDa	Contact	Minor allergen
<i>Psilocybe cubensis</i>	Mushroom	Psi c 2	Peptidyl-prolyl cis-trans isomerase (Cyclophilin)	16 kDa	Airway	Major allergen
<i>Rhizopus oryzae</i>	Mould	Rhi o 2	Peptidyl-prolyl cis-trans isomerase (Cyclophilin)	18 kDa	Airway	Major allergen

ABPA: allergic bronchopulmonary aspergillosis; *cross-reactive pan allergen families according to [1629]

Enolases* n=6

<i>Alternaria alternata</i>	Mould	Alt a 6	Enolase	45 kDa	Airway	Minor allergen
<i>Aspergillus fumigatus</i>	Mould	Asp f 22	Enolase	46 kDa	Airway	Minor allergen
<i>Cladosporium herbarum</i>	Mould	Cla h 6	Enolase	46 kDa	Airway	Minor allergen
<i>Curvularia lunata</i>	Mould	Cur l 2	Enolase	48 kDa	Airway	-
<i>Penicillium citrinum</i>	Mould	Pen c 22	Enolase	46 kDa	Airway	Minor allergen
<i>Rhodotorula mucilaginosa</i>	Yeast	Rho m 1	Enolase	47 kDa	Airway	Minor allergen

Dehydrogenases n=6

<i>Alternaria alternata</i>	Mould	Alt a 8	Mannitol dehydrogenase	29 kDa	Airway	Minor allergen
		Alt a 10	Aldehyde dehydrogenase	53 kDa	Airway	Minor allergen
<i>Candida albicans</i>	Yeast	Cand a 1	Alcohol dehydrogenase	40 kDa	Airway	Major allergen (asthma)
<i>Cladosporium herbarum</i>	Mould	Cla h 8	Mannitol dehydrogenase	28 kDa	Airway	Minor allergen
		Cla h 10	Aldehyde dehydrogenase	53 kDa	Airway	Minor allergen
<i>Malassezia furfur</i>	Dermatophyt	Mala f 4	Mitochondrial malate dehydrogenase	35 kDa	Contact	Major allergen

Peroxisomal protein (Redoxin*) n=6

<i>Aspergillus fumigatus</i>	Mould	Asp f 3	Peroxisomal protein (Redoxin)	19 kDa	Airway	Major allergen
<i>Candida albicans</i>	Yeast	Cand a 3	Peroxisomal protein (DJ-1/Pfpl family)	20 kDa	Airway	-
<i>Candida boidinii</i>	Yeast	Cand b 2	Peroxisomal membrane protein A (Redoxin)	20 kDa	Airway	-
<i>Penicillium citrinum</i>	Mould	Pen c 3	Peroxisomal membrane protein (Redoxin)	18 kDa	Airway	Minor allergen
<i>Malassezia furfur</i>	Dermatophyt	Mala f 2	Peroxisomal membrane protein (Redoxin)	21 kDa	Contact	Major allergen
		Mala f 3	Peroxisomal membrane protein (Redoxin)	20 kDa	Contact	Major allergen
<i>Malassezia sympodialis</i>	Dermatophyt	Mala s 5	Peroxisomal membrane protein (Redoxin)	18 kDa	Contact	Minor allergen

Thioredoxins* n=6

<i>Alternaria alternata</i>	Mould	Alt a 4	Disulfide isomerase (Thioredoxin)	57 kDa	Airway	Minor allergen
<i>Aspergillus fumigatus</i>	Mould	Asp f 28	Thioredoxin	13 kDa	Airway	Minor allergen (ABPA)
		Asp f 29	Thioredoxin	13 kDa	Airway	Major allergen (ABPA)
<i>Fusarium culmorum</i>	Mould	Fus c 2	Thioredoxin-like protein	13 kDa	Airway	Major allergen
<i>Coprinus comatus</i>	Mushroom	Cop c 2	Thioredoxin	12 kDa	Airway	-
<i>Malassezia sympodialis</i>	Dermatophyt	Mala s 13	Thioredoxin	13 kDa	Contact	Major allergen

Heat shock proteins* n=4

<i>Alternaria alternata</i>	Mould	Alt a 3	Heat shock protein 70	70 kDa	Airway	Minor allergen
<i>Aspergillus fumigatus</i>	Mould	Asp f 12	Heat shock protein P90	90 kDa	Airway	Minor allergen (ABPA)
<i>Penicillium citrinum</i>	Mould	Pen c 19	Heat shock protein P70	70 kDa	Airway	Minor allergen
<i>Malassezia sympodialis</i>	Dermatophyt	Mala s 10	Heat shock protein 70	86 kDa	Contact	Major allergen

Mn Superoxide dismutases* n=3

<i>Alternaria alternata</i>	Mould	Alt a 14	Manganese superoxide dismutase	24 kDa	Airway	-
<i>Aspergillus fumigatus</i>	Mould	Asp f 6	Mn superoxide dismutase	26.5 kDa	Airway	Major allergen (ABPA)
<i>Malassezia sympodialis</i>	Dermatophyt	Mala s 11	manganese superoxide dismutase	23 kDa	Contact	Major allergen

Transaldolases n=3

<i>Cladosporium cladosporioides</i>	Mould	Cla c 14	Transaldolase	36.5 kDa	Airway	Minor allergen
<i>Fusarium proliferatum</i>	Mould	Fus p 4	Transaldolase	37.5 kDa	Airway	Minor allergen
<i>Penicillium chrysogenum</i>	Mould	Pen ch 35	Transaldolase	36.5 kDa	Airway	-

YCP (Flavodoxin) n=2

<i>Alternaria alternata</i>	Mould	Alt a 7	YCP4 protein	22 kDa	Airway	Minor allergen
<i>Cladosporium herbarum</i>	Mould	Cla h 7	YCP4 protein	22 kDa	Airway	Minor allergen

Alt a 1 family n=2

<i>Alt a 1 family n=2</i>	Mould	Alt a 1	acidic glycoprotein	15.3/16.4 kDa	Airway	major allergen
<i>Alternaria alternata</i>	Mould	Ulo c 1	Alt a 1 homologue	17 kDa	Airway	major allergen
<i>Ulocladium chartarum</i>						

Fungal allergens can be distinguished from other allergen sources, like pollen or animal dander, by typical protein families, particularly by subtilisin-like serine proteases.⁹ These subtilisin-like serin proteases are characterized mostly as major allergens, that means more than 50% of mould sensitized subjects had specific IgE to these serine-protease allergens.⁸³⁷⁻⁸³⁹ Unfortunately, these allergens are currently not available for diagnostic purposes, therefore their clinical relevance could not be investigated in clinical trials or patient collectives. Cross-reactions were described for alkaline as well as for vacuolar serine proteases (group 13 and 18 allergens of Asp f, Asp fl, Pen b, Pen c, Pen ch and Pen o) based on positive sIgE in 20 to 80% of mould-sensitized subjects.^{840,841}

Another fungal specific cross-reactive allergen family belongs to 60S acidic ribosomal proteins. For Fus c 1 sensitization prevalence of 35% was measured in *Fusarium*-allergic subjects.^{840,841} It was further shown that the mycoprotein (Quorn) produced for human consumption by continuous fermentation of *Fusarium venenatum* on glucose substrate could induce IgE-mediated gastrointestinal

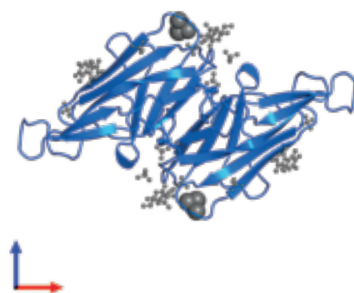
reaction 1-4 hs after ingestion.⁸⁴² In this clinical case the 60S acidic ribosomal protein P2 of *F. venenatum* was probably the reason.

The term fungal isomerases summarized five peptidyl-prolyl-cis-trans isomerase (cyclophilin) and one triosephosphate isomerase (TIM) as allergens. Protein family of cyclophilin were identified as allergens in mould and pollen. Mould Asp f 11 was ascertained as the major allergen (90% sensitization rates in *Aspergillus* sensitized subjects and Mala s 6 induced sensitization rates between 21 and 25% in patients with atopic dermatitis⁸⁴¹ [Twaroch, 2015 #1434]. The first fungal TIM was identified as allergen in *Aspergillus terreus* as Asp t 36 inducing allergic rhinitis and asthma in sensitized patients.⁸⁴³ TIM is highly conserved and a common allergen of sea food and mite allergy. Clinical relevance of fungal TIM has to be determined.

The Allfam enolase protein family comprised currently 12 allergens, of which six were identified in mould, four in fish, one in latex and one in chicken (Figure 69). Cross-reactions are described among enolase, Alt a 6, Cla h 6 and Hev b 9,⁸⁴⁴ as well as among Asp f 22, Pen c 22 and Alt a 6. Sensitization prevalence to fungal enolases was about 14 - 30% (minor allergen) in mould-sensitized subjects.^{840,841}

(A) Alt a 1 family AF196

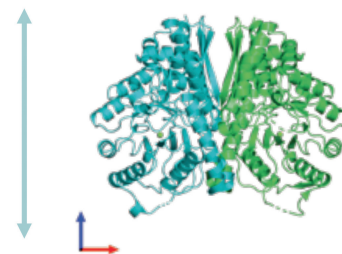
Alt a 1 ↔ Ulu c 1**



(B) Enolase AF031

Alt a 6 ↔ Cla h 6
Asp f 22

Cur l 2
Pen c 22
Rho m 1

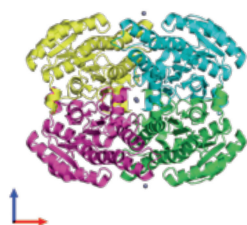


Hev b 9
Cyn d 22** Amb a 12**

Gal d 9
Thu a 2*
Cyp c 2*

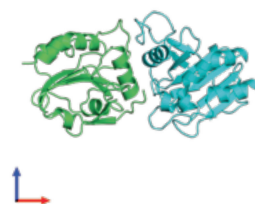
(C) Short chain dehydrogenase AF028

Cla h 8 ↔ Alt a 8



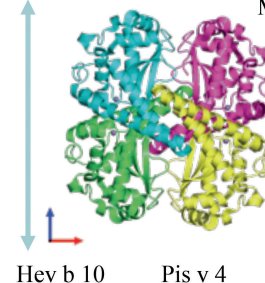
(D) Redoxin AF131

Asp f 3 ↔ Cand b 2 Pen c 3
Mala f 2 Mala f 3



(E) Fe/Mn superoxid dismutase AF020

Asp f 6 ↔ Alt a 14
Mala s 11



Hev b 10
Pis v 4

FIGURE 69 Ribbon diagram of commercially available mould allergens from EMBL-EBI Protein Data Bank in Europe (www.ebi.ac.uk/pdbe) showing (A) Homo dimer of Alt a 1 from *Alternaria alternata* (pdb-No: 3v0r); (B) Homo dimer of enolase of *Aspergillus fumigatus* (pdb-No: 7rhv); (C) Homo tetramer of NADP-dependent mannitol dehydrogenase from *Cladosporium herbarum* (Cla h 8) (pdb-No: 3gdf); (D) homo dimer of peroxiredoxin of *Aspergillus fumigatus* (Asp f 3) (pdb-No: 5j9b); (E) Homo tetramer of MnSOD of *Aspergillus fumigatus* (Asp f 6) (pdb-No: 1KKC). * not classified as AF031 allergen family but with biochemical function of beta-enolase according to WHO/IUIS database; ** not listed in Allfam

Fungal dehydrogenase were characterized as allergens covering four different allergen families and cross-reactivity was shown among mannitol dehydrogenases from *Cladosporium herbarum* Cla h 8 and Alt a 8.^{845,846} The sensitization rate against mould dehydrogenases was between 41 and 57% in mould-sensitized subjects.⁸⁴¹

Peroxisomal membrane proteins belong to the redoxin allergen family (Figure 69) and were exclusively found in fungi. Cross-reactive epitopes were described for Asp f 3 and peroxisomal membrane protein in *Candida boidinii*.⁸⁴⁷ In particular, Asp f 3 demonstrated high sIgE-binding potential of 49 - 72% in *Aspergillus*-sensitized subjects⁸⁴¹ and is useful for diagnostic differentiation between asthma and ABPA in *Aspergillus*-sensitized subjects. Five out of eight allergens characterized as thioredoxins are derived from moulds. About 50% of patients allergic to *Fusarium* had specific IgE against thioredoxin Fus c 2.⁸⁴¹ Another cross-reactive fungal allergen family comprised heat shock proteins (HSP 70) with Alt a 3 (5% sensitization (www.allergen.org)) and Pen c 19 (41% sensitization) in mould-sensitized subjects.⁸⁴⁰

Highly conserved protein structure is also found in manganese superoxide dismutases (MnSOD) with confirmed cross-reactivity between Asp f 6 and Alt a 1⁸⁴⁰ (Figure 69). MnSOD from *Aspergillus fumigatus*, Asp f 6, is also useful for diagnostic differentiation between asthma and ABPA in *Aspergillus*-sensitized subjects.

Three fungal transaldolase allergens have been identified exclusively in mould species. IgE cross-reactivity of Cla c 14 and Pen ch 35⁸⁴⁸ as well as Fus p 4 and Cla h 14⁸⁴⁹ has been shown. A possible contribution of transaldolase to allergic disorders has been discussed due to its homology to human autoantigens.^{848,849}

Mould allergens Alt a 7 and Cla h 7 belong to the flavodoxin protein family⁸⁴⁰ but had only minor sIgE-binding potency of 7 - 22% in mould-sensitized patients (www.allergen.org). Alt a 1, the major allergen of *Alternaria alternata* with a sensitization prevalence of more than 90% is one of the most clinically relevant fungal allergens.^{840,850} Alt a 1 consists of two subunits of a unique, dimeric β -barrel structure.⁸⁵² and a new allergen family with unknown function, but exclusively occurrence in fungi was introduced in AllFam list, as Alt a 1 family (Figure 69).

Among clinically important *A. fumigatus* single allergens Asp f 1 is a major allergen in patients suffering from ABPA (80 - 85%) as well as in *A. fumigatus* sensitized asthmatics (50 - 84.5%).⁸⁵³⁻⁸⁵⁵ Asp f 1 is

related to ribotoxins, which are known to inhibit protein translation and are highly toxic for humans and effectiveness of this allergen in diagnosis and therapy is still controversial.⁸⁴⁰ The protein family was not structurally classified by Allfam until now and cross-reaction to other allergens were not published. Asp f 2 has been described as major allergen in ABPA patients (87 - 100%)^{840,856} and was classified as metalloprotease M35 family AF211. However, there are no other allergens listed in this allergen family. Regarding Asp f 4, there was no classification to any allergen family, but in patients with cystic fibrosis or ABPA, Asp f 4 is a major allergen with about 80%.⁸⁴⁰

3 - Sensitization to individual molecules and their clinical relevance

The clinical availability of both skin prick tests and serological tools for IgE-mediated mould allergy diagnosis are continuously reducing, and standardization of mould extract is still difficult.^{857,858} The comparison of mould test solutions from different manufacturers showed a heterogeneous protein content, despite being prepared from supposedly identical allergen sources.⁸⁵⁸ This might be one reason for the discrepancy between skin prick test results and serologic IgE determinations. The concordance between skin tests and serological tests can be less than 30% depending on the mould species,^{835,1383} and skin tests were more sensitive compared with serological IgE-diagnosis. Therefore, molecular allergy diagnosis with recombinant mould allergens can offer valuable results. Using component-based serological tests rAlt a 1 and rAsp f 1, 2, 3, 4, 6 to measure serological sensitization to *Aspergillus fumigatus* and *Alternaria alternata*, 80% of extract-based serological sensitization were covered.⁸⁶⁹ Even though numerous fungal allergens have been identified, there are currently only eight single mould allergens commercially available for testing as shown in (Figure 70).

IgE to rAlt a 1 (available as single allergen and on multiplex platform) was measured in patients with sensitization to *Alternaria alternata* in 47% with atopic dermatitis and up to 98% in patients with allergic asthma.^{841,849,859} IgE-mediated sensitizations to *Alternaria* can be detected by testing rAlt a 1, which makes this single allergen valuable for standardization of test extracts.^{835,840,850,869} Among

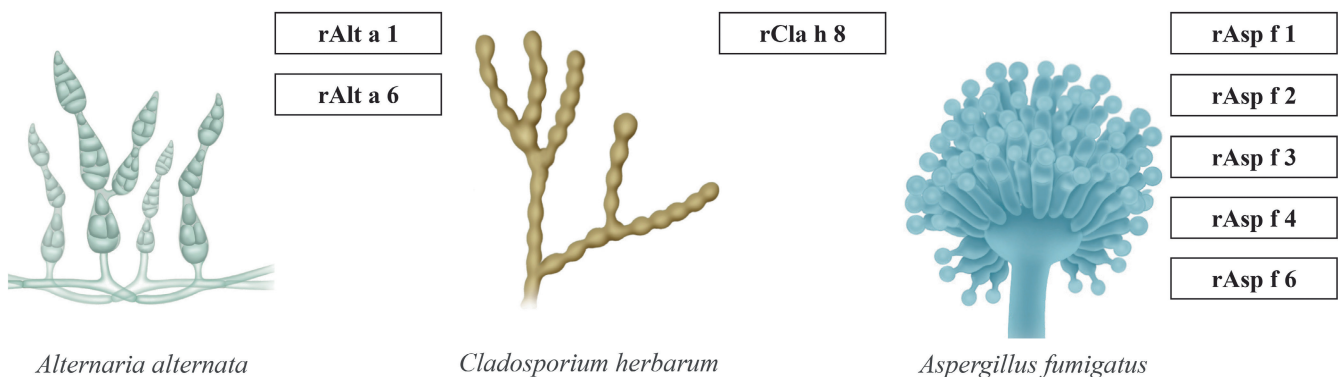


FIGURE 70 Electron-microscopic image of mould species with commercially available single allergens

Alternaria alternata sensitized patients (92% reported allergic rhinitis and 64.2% asthma) Alt a 1 sensitization occurred significantly more frequently in children (69.8%) than in adults (30.2%) as shown in a recent Spanish study.⁸⁶⁰ Sensitization to Alt a 1 is closely associated with asthma and increased asthma medication.^{55,841} The protein structure of Alt a 1 (Figure 69) is formed as a dimer of acidic glycoprotein without known biochemical function, with a unique butterfly-like dimer protein structure, which was exclusively found among mould proteins.⁸⁵² Cross-reactive structures of Alt a 1-homologues were identified in other Pleosporaceae genera like *Ulocladium* but not in mould genera such as *Aspergillus*, *Penicillium*, or *Cladosporium*. A clinical trial of Alt a 1 specific immunotherapy was recently published,⁸⁶¹ showing efficacy and safety of the applied subcutaneous immunotherapy, particularly with higher dose of Alt a 1. A comparison of this newly introduced component-based Alt a 1 SIT with extract-based *Alternaria alternata* SIT has to be evaluated.

IgE to Alt a 6 (available as allergen on multiplex platform) belong to enolase family and is a minor allergen in *Alternaria alternata*-sensitized patients with sensitization rates between 20 and 30%.⁸⁶² There are currently six fungal enolases (5 mould, 1 yeast, Figure 69) sharing sequence identity of 72 – 94% and IgE-binding epitopes were shown to be highly conserved and cross-reactive.⁸⁶² Enolases were identified further as allergens in animals (food) and plants (pollen and natural rubber latex) as shown in (Figure 69). Based on the known sequence homology, and conserve IgE-binding epitopes cross-reactions between these allergens are likely.⁸⁶² To date, IgE-cross-reactions were shown by inhibition studies for rHev b 9, rAlt a 6 and rCla h 6.⁸⁴⁰ IgE to Cla h 8 (available as allergen on a multiplex platform) is a short-chain dehydrogenase (Figure 69), with sensitization prevalence of 57.1% among *Cladosporium herbarum*-sensitized subjects.⁸⁴¹ Cross-reactions to other members of the short chain dehydrogenase family was described for Alt a 8 from *Alternaria alternata*.⁸⁴⁰

IgE to Asp f 1, 2, 3, 4, 6 (available as single allergens and multiplex platform) are valuable tools in differential diagnosis of ABPA in asthmatics with *Aspergillus fumigatus* sensitization^{854-856,863} (see clinical case⁸⁶⁴ below). Diagnostic criteria of ABPA in patients with asthma are still based on Rosenberg-Patterson criteria,⁸⁶⁵ which are applied until today with small modifications.⁸⁵⁵ The diagnosis of ABPA can be made if six out of eight main criteria are given. One of these main ABPA diagnosis criteria is sIgE-binding to *Aspergillus fumigatus* and previous studies showed sIgE to Asp f 2 plus Asp f 4 plus Asp f 6 occurred more frequently in patients with ABPA than in asthmatic.^{854,866} A more recent meta-analysis⁸⁶³ investigating Asp f recombinant allergens in 26 studies (including 1694 patients) revealed that IgE to Asp f 1 or Asp f 3 had the highest sensitivity (96.7% in asthmatics and 93.3% cystic fibrosis (CF)-patients) to differentiate ABPA among these patients, but Asp f 4 or Asp f 6 had the highest specificity with 99% in asthmatics versus Asp f 6 alone with 98% in CF-patients. It is therefore not trivial to designate one specific Asp f allergen or a combination pattern of Asp f single allergens as diagnostic markers for ABPA. What has almost always been shown, however, is that sIgE to recombinant Asp f allergens were

detected significantly more often and with higher concentrations in patients with ABPA.

Regarding type I allergy diagnosis a typical major allergen, comparable to Alt a 1 in *Alternaria alternata*, is missing in *Aspergillus fumigatus*, as well as in all other mould species. Recombinant Asp f allergens can be grouped into secreted allergens comprising Asp f 1 and Asp f 3 and nonsecreted allergens (Asp f 4 and Asp f 6).⁸⁶³ In a study⁸⁶⁹ investigating single *Aspergillus fumigatus* components in *Aspergillus*-sensitized patients with and without asthma most frequently sIgE to rAsp f 1 with 53% and rAsp f 3 with 47% were measured, followed by rAsp f 2 and rAsp f 4 with 26% and rAsp f 6 with 16% in all sensitized subjects. There was no significant difference in sIgE sensitization to single rAsp f components depending on asthma, sIgE to rAsp f 1 / rAsp f 3 was measured in 46% / 46% of asthmatic and 67% / 50% of nonasthmatic *Aspergillus* sensitized patients. Frequency of sIgE to rAsp f 2, Asp f 4 and Asp f 6 were 15 – 31% in asthmatics and 17% in nonasthmatics comparable. These results correspond with the previously described compartments of Asp f 1 and Asp f 3 as secretory proteins with high IgE-binding frequency compared with Asp f 2, Asp f 4 and Asp f 6 as intracellular proteins with lower IgE-binding frequency.

4 – Clinical management

For clarification of a mould-associated respiratory allergy anamnesis, prick testing or serological IgE determination are recommended according to the diagnostic allergy algorithm (Figure 71). Since more and more mould test solutions are being withdrawn from the market,⁸⁶⁷ serological IgE determination is almost the only test tool available, although it is often less sensitive than skin prick tests.¹³⁸³ In principle any mould can cause IgE sensitization and the exact determination of mould exposure is not possible in most cases. *In vitro* testing of a mould mixture (mx1) consisting of *Alternaria alternata*, *Cladosporium herbarum*, *Aspergillus fumigatus* and *Penicillium chrysogenum* was shown to be sufficient to detect IgE reactions to all the contained individual mould species.^{868,1383} If mould-associated IgE is measurable, a possible exposure should be verified anamnestically (indoor versus outdoor) and possible co-sensitizations such as grass pollen or house dust mites, which represent overlapping allergen exposures, must be investigated (Figure 71).

5 – Clinical Cases

The presented case report was recently published by.⁸⁶⁴

Patient history

A 55 year old man reported rhinitis and cough with viscous secretion over two month and occasional discrete shortness of breath and mucus plug secretion associated with cough in 2010. Tree pollen allergy with seasonal rhino-conjunctivitis in March - April and oral allergy syndrome to *Rosaceae* fruits (e.g. apple) has been known for many years but had improved during last years. The patient had a

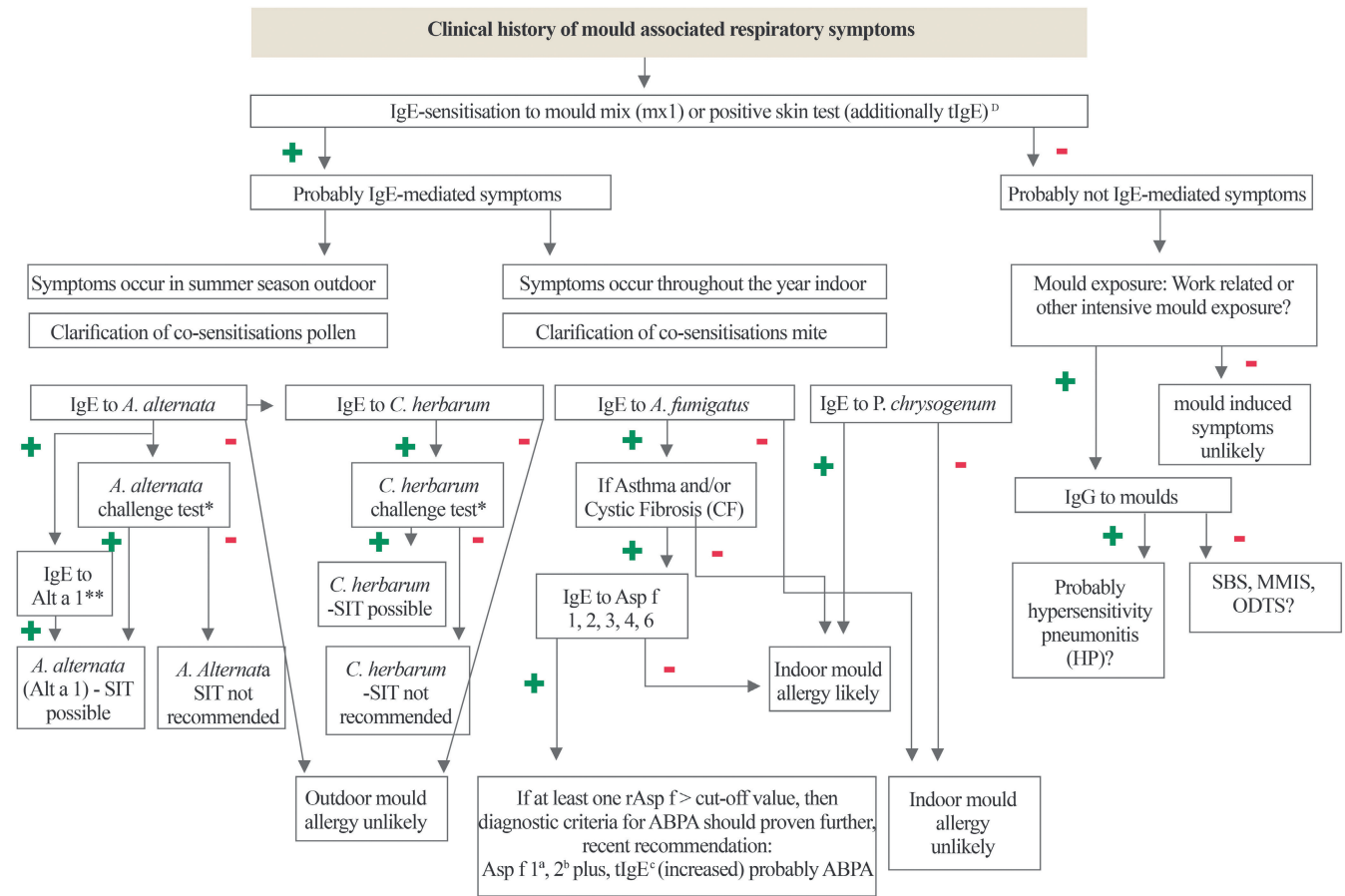


FIGURE 71 Decision algorithm for patients with clinical history of mould associated respiratory allergy; Mould mix (mx1): *Aspergillus fumigatus*, *Penicillium chrysogenum*, *Cladosporium herbarum*, *Alternaria alternata*; D recommendation according to ¹⁴⁵; *recommendation according to ¹³⁹⁷ **optional, a cut-off IgE to Asp f 1 > 4.47 kU/L; b cut-off IgE to Asp f 2 > 1.3 kU/L; c cut-off total IgE > 417 IU/ml according to ⁸⁵⁶; SBS: sick building syndrome; MMIS: mucous-membrane irritation syndrome, ODTs: organic dust doxic syndrome (endotoxin, mycotoxins)

good general condition and was neither obviously exposed to dust or mould nor to pets.

Clinical examination

The clinical examination in 2010 showed apically attenuated breath sounds on auscultation in both lungs with otherwise normal findings. Lung function showed a borderline obstructive disorder with normal vital capacity, but fractionated FeNO was significantly elevated at 95 ppb, indicating a Th-2 asthma bronchiale.

SPT

In 2010 strong skin reactions were shown in prick test to birch and ash pollen, as well as to the moulds *Aspergillus fumigatus* and *Alternaria alternata* and a weak reaction to house dust mites.

In-vitro testing

Serologically, a massively increased total IgE (>6000 kU/L) was measured, as well as strongly increased sIgE concentrations to *Aspergillus fumigatus* (78.5 kU/L, CAP class 5) and *Alternaria alternata* (100 kU/L, CAP class 6). Additionally, high sIgG concentration on *Aspergillus fumigatus* in the sense of a type III allergic reaction, as well as an eosinophilia, were indicative of a possible ABPA. Serological testing for the components rAsp f 2 (11.1 kU/L,

CAP class 3), rAsp f 4 (0.53 kU/L, CAP class 1) and rAsp f 6 (0.40 kU/L, CAP class 1) underlined the suspicion of ABPA.

Diagnosis

According to the Rosenberg-Patterson diagnostic criteria,⁸⁶⁵ five major and two minor criteria were present and the criteria of the International Society for Human and Animal Mycology (ISHAM)⁸⁵⁵ were also fulfilled, therefore the diagnosis of ABPA was made.

Disease progression

After a long stable course under inhaled asthma therapy and a steady decrease in total IgE and sIgE to *Aspergillus fumigatus*, clinical worsening occurred in 2014 and 2015 with significant increases of total IgE and sIgE to *Aspergillus fumigatus* and the components rAsp f 2, rAsp f 4 and rAsp f 6. The relapses were ameliorated by systemic steroid administration for several weeks, and no further attacks occurred during the last four years under inhaled asthma therapy. A chest CT performed in May 2016 did not reveal bronchiectasis.⁸⁶⁴

Diagnostic tools

The importance of sIgE to Asp f 2, 4 and 6 in the diagnosis of ABPA in both asthma and cystic fibrosis (CF) patients, as described initially,⁸⁶⁶ and calculation of a recent meta-analysis⁸⁶³ showed

that ABPA diagnose specificity based on sIgE ≥ 0.35 kU/L for Asp f 4 plus Asp f 6 was 99.2%. A further study from India⁸⁵⁶ was able to show that Asp f 1 (≥ 4.4 kU/L) and Asp f 2 (≥ 1.3 kU/L) are valuable tools to differentiate between *Aspergillus fumigatus*-sensitive asthmatics and asthmatic patients with ABPA with a sensitivity of 100% and a specificity of 81%. Thus, in the future, sIgE to Asp f 1 and Asp f 2 in combination with total IgE can prevail instead of sIgE to *Aspergillus fumigatus* extract. To confirm the ABPA diagnosis, sIgE against Asp f 4 and Asp f 6 could be measured. However, the transfer of results obtained with the serological parameters (Asp f 1 and Asp f 2) to European patient collectives still needs to be verified. As general recommendation for patients with asthma or cystic fibrosis determination of total IgE is useful to avoid overlooking ABPA.⁸⁶⁴

6 – Research and future perspectives

Due to the difficult production and standardization of mould allergen extracts, it is highly demanded to improve mould allergy diagnosis using single allergen components.

In the future, subtilisin-like proteases and other mould typical cross-reactive allergen families could be helpful in molecular allergy diagnosis of moulds.

Especially diagnostic evaluation of single Asp f allergens for differentiation between asthma and ABPA should be verified for more ethnic groups of patients.

B08 – Microbial allergens /antigens

Carole Guillet, Rebecca Czolk, Philipp Bosshard, Peter Schmid-Grendelmeier, Annette Kuehn

Highlights

- *Malassezia species* are commensals of the normal skin flora and are part of the skin microbiome.
- Sensitization to *Malassezia species* allergens can frequently be found in head and neck type atopic dermatitis.
- Fourteen allergens from 3 *Malassezia species* have been characterized to date.
- The skin microbiome, especially *Malassezia spp* and *Staphylococcus aureus*, can be a target in AD therapy.
- The impact of commensal microbiomes on allergies and other barrier diseases is a rapidly growing research field.

1 – Introduction

The skin is a complex ecosystem harboring diverse and site-specific microbial communities referred to as the skin microbiome. Phylogenetic profiling of the skin microbiome of healthy individuals revealed that bacteria are predominant at most body sites.⁸⁷⁰ Additionally, fungi—also referred to as skin mycobiome—play an essential part in these microbial communities. They account for 1% to 22% of the phylogenetic composition of the skin microbiome. In healthy skin, the fungal flora almost exclusively harbors *Malassezia species (spp.)*.⁸⁷⁰

Studies suggest a significant role of the skin microbiome in the development and progression of atopic dermatitis (AD).^{871,872} AD is a chronic inflammatory skin disease characterized by eczematous lesions, pruritus, and a chronic/ relapsing history of symptoms.^{872,873} Its prevalence has increased over the last decades affecting 15–30% of children and 10% of adults.^{873,874} Several factors such as an impaired barrier function of the skin, altered skin immune system, and skin microbial dysbiosis contribute to the development of AD.^{874,875} Cutaneous yeasts can trigger or aggravate inflammation of the skin in AD. Especially in patients with head and neck type AD, a common subtype, IgE specific to *Malassezia* antigens, can be found.^{875,876} This can be explained by an increased sebaceous gland activity in this area.^{875,876}

Malassezia spp. specific IgE levels were identified as a marker for the severity of AD^{876,877} and in AD patients with elevated specific IgE to *Malassezia* allergens, antifungal treatments can be beneficial.^{877,878} In the following sections, we will discuss the importance of the skin microbiota in AD and review the possible interactions between microbial allergens and the immune system in atopic skin. We will focus on fungal allergens, but we will also briefly discuss the role of allergens from bacteria.

2 – The allergen sources

Malassezia is a genus of lipophilic yeasts and belonging to the phylum of Basidiomycota. Of currently 14 known species, nine can be isolated from human skin and five from animal skin (Table 29).^{878,879} Zoonotic transmission of *M. pachydermatis*, for example, from dogs to neonates by dog owning health care workers is possible.^{879,880}

Malassezia spp. lack genes for synthesizing fatty acids and are therefore dependent on an exogenous fatty acid source, such as skin lipids, to meet their nutritional needs.^{880,881} *M. globosa* and *M. restricta* are the two predominant species found on healthy human skin and different body sites.^{882,883,884} A geographical variation in distribution patterns of *Malassezia* species owing to climatic factors was found in several studies. In Japan, *M. furfur* was the most frequent species, and in Canada, Russia, and Sweden, *M. sympodialis* was the most common.^{883,884} Furthermore, a study from Switzerland and Tanzania recently showed that Swiss AD patients living in Switzerland are quite frequently sensitized to *Malassezia spp.*—whereas patients from patients with AD living in Tanzania are rarely sensitized to it. This finding suggests that there may also be significant ethnic differences between *Malassezia* sensitization.^{884,885} Several studies have compared the colonization of different *Malassezia spp.* in healthy and AD skin, though no consistent difference was found.^{883,884}

3 – Allergen families

Currently, 14 different *Malassezia* allergens are characterized, and all of them are produced by three *Malassezia* species, namely *M. furfur*, *M. sympodialis*, and *M. globosa* (Figure 72). The function of some *Malassezia spp.* allergens are known.

M. furfur allergens Mala f 2 and Mala f 3 are peroxysomal membrane proteins, and Mala f 4 is a mitochondrial malate dehydrogenase. The functions of *M. sympodialis* allergens are known for Mala s 6, s 10, s 11, s 12, and s 13. Mala s 6 is a cyclophilin, and Mala s 13 is a thioredoxin—both being potential pan-allergens. The crystal structure of some of these allergens has been resolved (Figure 73).^{885,886}

4 – Allergenic molecules (epidemiology incl. geography and function)

Thirteen *Malassezia* allergens, all of which are produced by *M. furfur* or *M. sympodialis*, are listed in the official allergen nomenclature list of the International Union of Immunological Societies (IUIS, www.allergen.org). Two *Malassezia* allergens have raised special attention, namely Mala s 11 and Mala s 13. Mala s 11 is 50% homologous in its amino acid sequence with human manganese superoxide dismutase (MnSOD)⁸⁸⁸ and 56% homologous to the MnSOD from *Aspergillus fumigatus* (rAsp f 6). On the Compare Database (<https://comparedatabase.org>) cross-reactivity to other

MnSODs such as Hev b 10 and Alt b 14 is below 50% and thus cross-reactivity should not be expected. Mala s 13 is a thioredoxin and has a 45% sequence identity with human thioredoxins and can thus also lead to cross-reactivity and autoreactivity in patients suffering from AD.^{871,887,889} Furthermore, the allergen MGL_1304 derived from *M. globosa* was shown to induce mast cell degranulation and trigger the release of IL-4 in basophils. Elevated levels of

IgE against this allergen in sweat were detected in AD patients and patients suffering from cholinergic urticaria.⁸⁹⁰ Crystal structures are given in (Figure 73).

5 – Sensitization to individual molecules and their clinical relevance

As *Malassezia* spp. are part of the normal skin flora, specific IgG and IgM antibodies to *Malassezia* spp. can regularly be found in non-atopic human patients.⁸⁸¹ However, healthy individuals usually do not have detectable levels of *Malassezia*-specific IgE antibodies.

By contrast, 30-80% of adult AD patients are sensitized to *Malassezia* spp. as demonstrated by positive atopy patch tests, skin prick tests (SPT), or detectable serum levels of specific IgE antibodies.^{892,893} *Malassezia*-specific IgE is found in 5 - 27% of children and 29 - 65% of adults with AD, consistent with the rates found by SPT.^{876,877} The lower frequency of *Malassezia* sensitization in children compared with adults could be related to the poor growing conditions for *Malassezia* spp. in children. The lipid content of sebum, a prerequisite for skin colonization for most *Malassezia* spp., is low in children but rises during puberty.⁸⁹⁴ Accordingly, sensitization to *Malassezia* spp. seems to occur preferably in adulthood, and therefore later than the sensitization to food allergens and aeroallergens, which frequently occurs during childhood.⁸⁷⁷ The sensitization rate against particular allergens from *Malassezia* spp. is shown in the Online Repository Table 29. The currently proposed role of *Malassezia* allergens in the pathogenesis of AD is depicted in (Figure 74).

TABLE 29 Currently identified *Malassezia* species

<i>Malassezia</i> species	Degree of cross-reactivity	Isolated from Animal	Description as species (year)
<i>M. caprae</i>		x	2007
<i>M. cuniculi</i>		x	2011
<i>M. dermatis</i>	x		2002
<i>M. equina</i>		x	2007
<i>M. furfur</i>	x	x	1889
<i>M. globosa</i>	x	x	1996
<i>M. japonica</i>	x		2003
<i>M. nana</i>		x	2004
<i>M. obtusa</i>	x		1996
<i>M. pachydermatis</i>		x	1925
<i>M. restricta</i>	x		1996
<i>M. slooffiae</i>	x	x	1996
<i>M. sympodialis</i>	x	x	1990
<i>M. yamatoensis</i>	x		2004

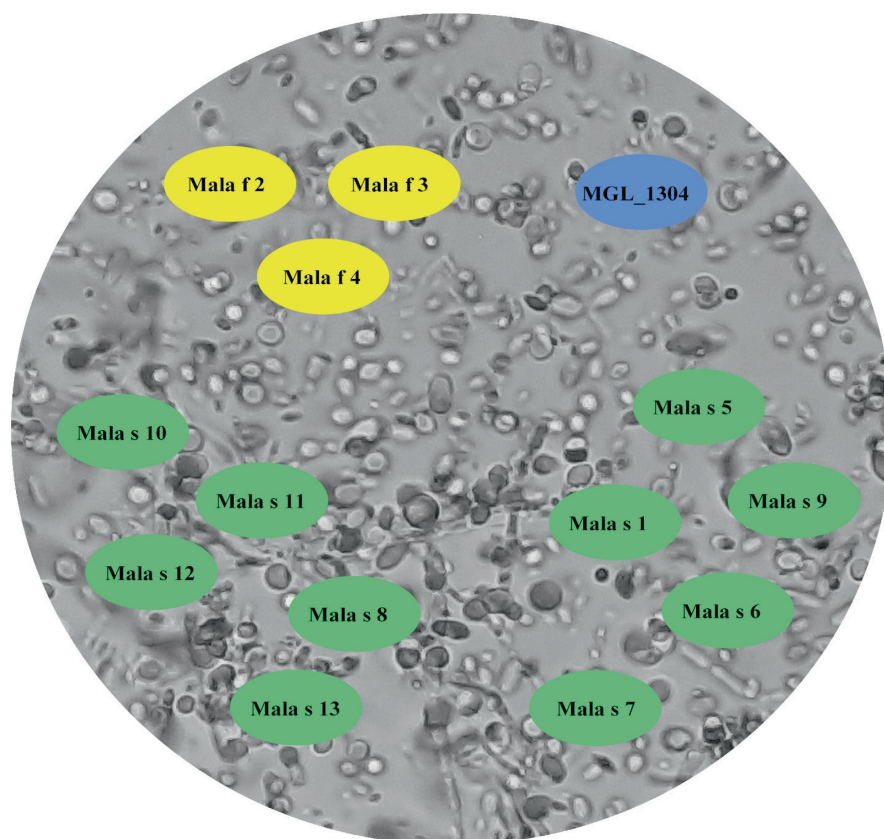


FIGURE 72 14 known *Malassezia* allergens from three *Malassezia* species

FIGURE 73 (A) Crystal structure of Mala s 13. Image from the RCSB PDB (rcsb.org) of PDB ID 2J23.⁸⁸⁶ Image created with Mol*.⁸⁹¹ (B) Crystal structure of Mala s 6. Image from the RCSB PDB (rcsb.org) of PDB ID 2CFE.⁸⁸⁷ Image created with Mol*.⁸⁹¹

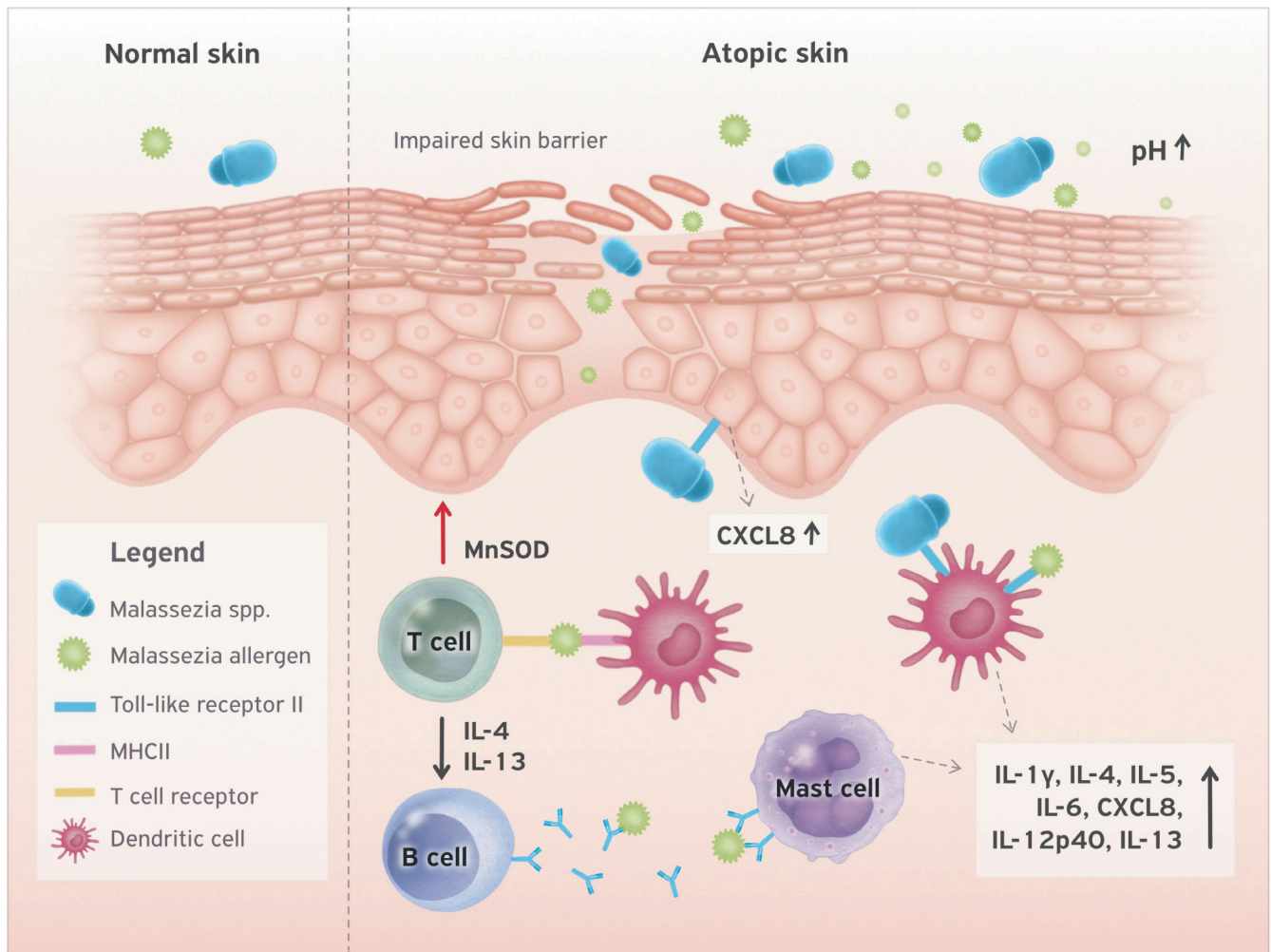
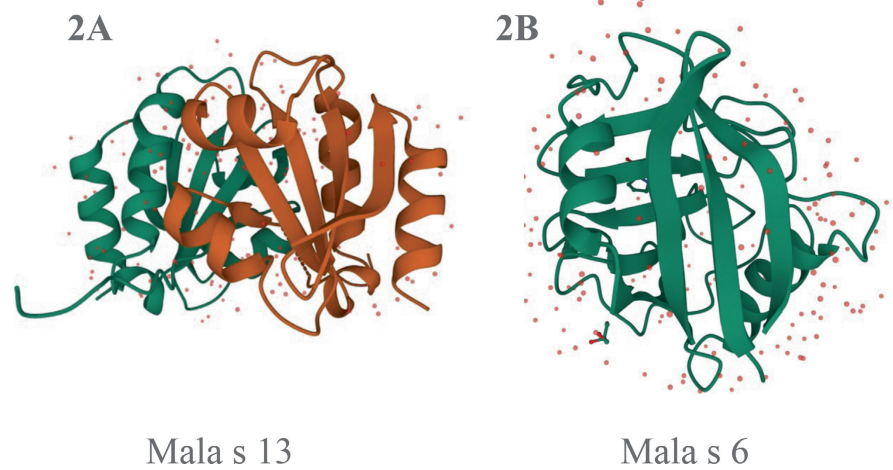


FIGURE 74 Proposed mechanisms of *Malassezia* spp. allergen-induced skin inflammation in atopic dermatitis (AD)

6 – Clinical relevance of sensitization

An elevated skin pH as in AD leads to an increase in release of *Malassezia* spp. allergen. These allergens can consecutively

penetrate the skin barrier, which is disturbed in atopic skin. Allergens are recognized by dendritic cells and keratinocytes via Toll-like receptor II. This stimulates the release of pro-inflammatory cytokines and induces the production of IgE antibodies. Autoreactive T cells

cross-react between fungal and human manganese-dependent superoxide dismutase (Mala s 11) or thioredoxin (Mala s 13), hence sustaining skin inflammation.

The interaction between *Malassezia* and the skin immune system contributes to the inflammation typical of AD. *M. sympodialis* produces higher amounts of the allergen Mala s 12 when cultured under high pH conditions reflecting the higher pH of atopic dermatitis compared with normal skin. This might contribute to *Malassezia*-related skin inflammation in AD.⁸⁹⁵

7 – Clinical management

Diagnosis

The diagnosis of *Malassezia*-associated AD is based on the clinical picture. It may be supported by a positive type I allergic reaction to *Malassezia spp.*, measured by a positive skin prick test, or by measuring *Malassezia*-specific serum IgE with a commercially available standardized assay (the ImmunoCAP Specific IgE test m227) based upon three different *Malassezia* species.⁸⁷⁶ Furthermore, a recently developed multiplex IgE macroassay (MacroArray Diagnostics GmbH, Vienna, Austria) is available, including the allergens Mala s 5, 6, and 11. Based on its sequence homology, Asp f 6 shows high cross-reactivity with Mala s 11 and can be measured additionally. Total IgE measurements can allow to determine the sensitization attributable to the whole extract, e.g., it can be expressed as a ration or percentage; it also gives hints on the reduced sensitivity of specific gE in very low amounts of total IgE (<25 kU/l). Atopy patch testing has shown varying results. Some studies have shown no correlation between IgE and atopy patch test for *Malassezia*. By contrast, others have found a positive atopy patch test in 41% of patients with head and neck dermatitis and 30% in AD patients without head and neck involvement.^{876,892,896} Culturing *Malassezia spp.* from the skin is not commonly used in the routine clinical care of AD patients.

Treatment

The benefit of topical or systemic antifungal treatment for clinical improvement of AD is controversial. Azole antifungals are the most commonly prescribed class of antifungals for AD patients. Azole antifungals show inhibitory effects against *Malassezia spp.* *in vitro*.^{894,897}

Based on our anecdotal experience in routine clinical practice, topical application of ketoconazole to the face of patients with head-and-neck-type AD often improves eczema.

Several randomized, placebo-controlled trials have investigated the effect of systemic antifungal treatment on AD. Some have shown a significant difference in reduction of AD severity in patients treated with oral ketoconazole vs. placebo or oral itraconazole vs. placebo.^{898,899} However, the relevance of these results to routine clinical practice remains to be demonstrated.

8 – Clinical case⁹⁰⁰

Clinical history

A 37-year-old patient presented with severe head and neck type atopic dermatitis (EASI score: 43). Since childhood, the patient had suffered from AD. The eczema flare-ups occurred mainly after physical exertion and heavy sweating. Other trigger factors, such as seasonal factors or the consumption of certain foods, were negative. Previous therapies included topical emollients, topical steroids, phototherapy for three months, and the use of cyclosporine for one month (intolerance due to severe headache).

Test with extracts and molecules

Skin prick tests with the most common seasonal and year-round inhaled allergens were negative. Serum levels of total IgE (523 kU/L; norm <100 kU/L) and specific IgE against *Malassezia spp.* (m227) (53.2 kU/L; norm <0.35 kU/L) and rAsp f 6 (22.4 kU/l; norm <0.35 kU/L) were markedly elevated while, IgE against rAsp f1 and rAsp f4 were not elevated.

Patch testing showed positive reactions to *Malassezia spp.* extract (+++), as well as to the isoforms of manganese superoxide dismutase (MnSOD) from *Aspergillus fumigatus*, rAsp f 6, (+++), and humans (++) (Table 30)

Conclusion

These findings are consistent with a marked sensitization to fungal allergens (MnSOD) and their human homologues. Treatment with a peroral antifungal (itraconazole 100 mg 2× daily for two weeks) in addition to emollients and topical steroids was initiated resulting in rapid but transient improvement of his AD. Currently, the patient uses topical antifungals on his face and neck and an antifungal shampoo every four to six weeks, which has resulted in a marked improvement in eczema and a decrease in the frequency of AD flare-ups.

TABLE 30 Test results

Serum IgE	Value [KU/L]	Interpretation
Total IgE	523.0	Elevated
Inhalant allergen screening (sx1)	0.2	CAP-Class
Food Screening (fx5) <i>Malassezia spp.</i> (m227) <i>Aspergillus fumigatus</i> (m3)	0.3	0 CAP-Class
rAsp f 6 (m222)	53.2	0 CAP-Class
rAsp f 1 (m218)	12.4	5 CAP-Class
rAsp f 4 (m221)	22.4	3 CAP-Class
Mold mix (mx2)	0.2	4 CAP-Class
	0.3	0 CAP-Class 0
	24.1	CAP-Class 4

Patch testing (assessment after 48 hours)

<i>Malassezia spp.</i> Extract Fungal	+++	Highly positive
MnSOD (r-Asp f 6) Human	++++	Highly positive
MnSOD	++	Positive

Suggested serological investigations in patients with confirmed atopic eczema and suggested analyses in patients with suspicion of AD are shown in Figure 75.

9 – Research and future perspectives

Atopic Dermatitis: skin microbial agents and their role Singleplex assays currently used in the diagnosis do not provide component-resolved analysis based on *Malassezia* allergens: Complementary to the usual skin prick and extract tests, allergen-specific IgE might give an outlook on disease prognosis and severity, as said earlier. Even though molecular diagnostic tools are not yet well established in routine use, as a perspective, they might even become a helpful marker for disease endotypes. Widespread clinical use of allergen-based assays

will contribute to the elucidation of these connections. *Malassezia* spp. do not overgrow in AD patients, giving rise to the question how *Malassezia* becomes a sensitizing agent specifically in AD.⁸⁸³ From a mouse model it seems that *Malassezia* spp may have important regulatory function in AD by inducing IL-17 and related cytokines.⁸⁹⁹

Another hypothesis is that a disturbed skin barrier leads to an altered interplay between fungal and bacterial communities, triggering allergic sensitization. *Staphylococcus aureus*, one of the main bacteria in the skin microbiome, more frequently colonizes lesional (70%) and nonlesional skin (39%) of AD patients than the skin of healthy individuals (10%). *Staphylococcus aureus* enterotoxins are the primary source for sensitization. 33% of AD patients have specific IgE against enterotoxin A (SEA), and 35% against enterotoxin B (SEB), with lower sensitization numbers for other SEs. Sensitization to *S. aureus* allergens correlates with the severity of AD. Other bacterial strains, such

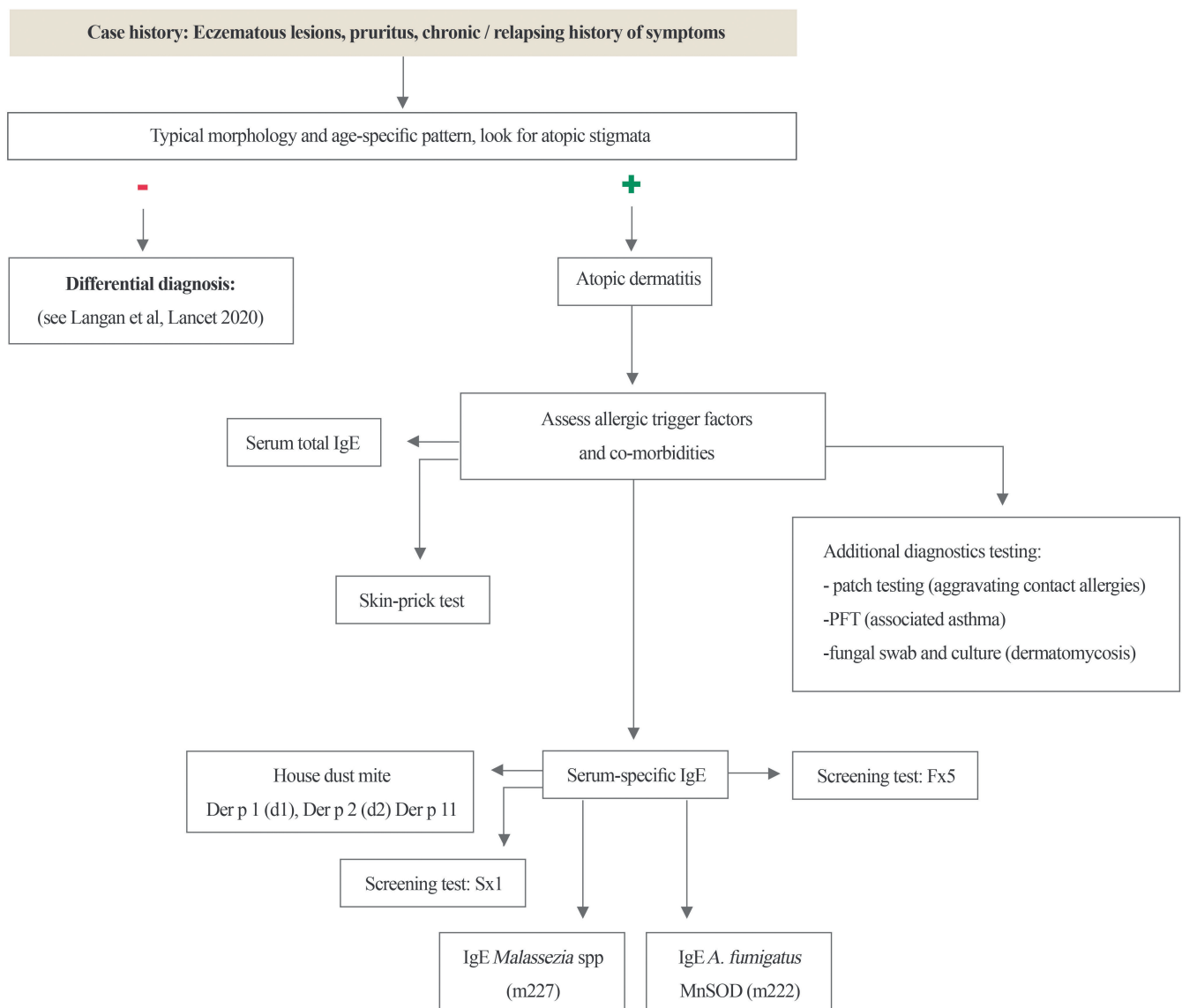


FIGURE 75 Diagnostic algorithm in suspected atopic dermatitis and suggested serological investigations in patients with confirmed atopic eczema. Abbreviations: PFT Pulmonary Function Test. Reference: 873

as *Corynebacterium* and the *Proteobacteria*, have been associated with AD severity; however, no IgE-reactive proteins could be identified so far.⁹⁰¹ Further research is needed to understand the interplay between fungal and bacterial skin microbiome components, to illuminate different possible cause and effect mechanisms of antigen-immune interactions on the skin.

Asthma: disrupted barriers and pathogen interactions Other barriers between host and microbiome are also the scene of allergic reactions, such as the respiratory tract in allergic asthma or rhinitis. In the lungs, fungal and bacterial antigens appear implicated in aggravating allergy symptoms. Fungal allergens from

Aspergillus, *Cladosporium*, *Penicillium*, and *Alternaria* have been shown to play a significant role in asthma (see additionally chapter B07). The IgE-reactive *S. aureus* proteins involved in AD are also of importance in asthmatic lungs. Approximately 25% of asthma patients present with SEB-sIgE and 15% were sensitized to SEA. Other bacterial proteins, mostly from strains associated with lung infections, also seem to elicit an allergic response. *Chlamydia pneumoniae*'s cysteine-rich membrane protein A (CrpA), major outer membrane protein (MOMP), lectin-binding proteins (LBPs), chlamydial heat shock protein 60 (HSP60), and lipopolysaccharide (LPS) were identified to bind specific IgE. For *Haemophilus influenzae*, IgE is bound to the outer membrane proteins P4 and P6 and the surface protein C (PspC) of *Streptococcus pneumoniae*. The presence of *Moraxella* in the lungs early in life has also been associated with increased asthma risk, although the mechanism and reactive structures are not known yet.⁹⁰² So far, known IgE reactive bacterial antigens are not classified as named allergens and therefore not yet available for diagnostic purposes, although the field is evolving rapidly. Measurement of IgG against bacteria may be useful in the diagnostic workup of other

immune-mediated diseases, such as hypersensitivity pneumonitis; however, this is beyond the scope of this article.

Food allergy: intestinal microbiome and immune modulation

The intestinal tract is one of the body's most significant barriers between the host, a complex microbial community, and foreign agents, such as food. The commensal microbiome has been associated with beneficial immune modulation, but a disturbance in the cross-talk between microbes and host may have the opposite effect. This field of research is ever-expanding and has established connections between the corruption of host barriers and allergy. Primary sensitization to peanuts through the skin, *S. aureus* colonialization of the skin as a driver for food allergy, or gut microbial dysbiosis in asthmatic children have been reported.

A disrupted and dysfunctional intestinal barrier appears to be relevant in the pathogenesis of food allergy.⁹⁰³ An increase of IgE+ B-cells in patients with peanut allergy gives even credence to the thought of tissue-specific effects in allergic disease.⁹⁰⁴ This seems to be accompanied by dysbiosis, showing a pattern of over- or underrepresentation of bacterial strains to be food allergy-specific.⁹⁰³ Fecal bacteria turned out to be a target for IgE binding, leading to the question of the role of the microbiome in eliciting allergic responses.⁹⁰³ The concept of bacteria mimicking disease-related targets has recently been demonstrated in celiac disease, a chronic autoimmune disorder.⁹⁰⁵ Overall, disruptions in the delicate balance between host immune system, barrier integrity, and microbiome seem to have an influence on disease development, as well as progression and severity.⁹⁰⁷ More research will be needed to identify diagnostically relevant antigen structures on commensal bacteria and fungi to verify their IgE reactivity and biomarker capacity.

B09 – Edible insects

Kitty C. M. Verhoecx, André C. Knulst

Highlights

- Clinically relevant cross-reactivity between mealworm and shrimp has been found.
- Primary sensitization to insects (mealworms) is possible.
- Important allergenic proteins are tropomyosin and arginine kinase (cross-reactivity).
- Currently good diagnostic tools for insect food allergy are missing.
- In case of unclear clinical history and serology, food challenges are necessary to confirm the diagnosis.

1 – The allergen sources

With an increasing world population and demand for sustainable food sources, insects are a promising alternative source of protein.⁹⁰⁷ Almost 2000 insect species are consumed globally by approximately two billion people.⁹⁰⁸ Insects are consumed in Asia, Latin America, and Africa. Entomophagy is not yet common practice in Europe and North America (FAO, 2013). Nevertheless, people already unknowingly ingest approximately 500g of insect traces per year.⁹¹⁰ The top eight most frequently consumed insect orders are Coleoptera (beetles), Lepidoptera (caterpillars), Hymenoptera (ants, wasps, and bees), Orthoptera (locusts, grasshoppers, and crickets), Hemiptera (leafhoppers, plant hoppers, cicadas, scale insects, and true bugs), Odonata (dragonflies), Isoptera (termites), and Diptera (flies).

Because insects were not frequently eaten in Europe before May 1997, they are classified as novel food by the EU Commission.⁹¹¹ Recently the EU Commission approved the introduction of the yellow mealworm (*Tenebrio molitor*) on the food market.⁹¹² Insects such as the yellow mealworm consist mainly of protein, fat and fibre and are proposed to be consumed as a whole, dried insect or in the form of powder, added to various products such as energy bars, pasta, and biscuits. Information on adverse reactions after eating insects is scarce, they are sporadically reported in case reports. The prevalence of food allergy to insects was only described in three population studies. In Laos a prevalence of 7.6% was found under entomophagists consuming insects,⁹¹³ in China 18% of reported cases of anaphylaxis to food was related to the ingestion of insects⁹¹⁴ and in Korea 3.1% of food allergic patients were allergic to silkworm.⁹¹⁵ More information can be found on allergic reactions caused by insect sting bites or inhalant allergies due to insect exposure, e.g., to cockroach. For information on these allergies we refer to other chapters (B05, B20, and B21).

2 – Allergen families

According to the simplified phylogenetic tree (Figure 76) insects are part of the Arthropoda phylum and closely related to Crustacea (shrimp and lobster) and to the subclass Acari (house dust mite), which are (food) allergenic sources. They contain the well-known invertebrate pan-allergens tropomyosin and arginine kinase.⁹¹⁶

Tropomyosin belongs to the tropomyosin family and has been identified as a major allergen in house dust mite (Der p 10), crustaceans (Pen m 1), moths (Bomb m 3), and cockroach (Bla g 7) but also in herring worm *Anisakis simplex* (Ani s 3) and common roundworm *Ascaris lumbricoides* (Asc l 3) (see also chapters B04, B05, B12, B13, C05). Until now 39 tropomyosins have been registered, 27 as food allergen, 11 as airway allergen and one as injection allergen, according to the WHO/ IUIS allergen nomenclature subcommittee. Tropomyosin typically consists of two parallel alpha-helical tropomyosin molecules that are wound around each other forming a coiled-coil dimer and are characterized by high amino acid (AA)-sequence identity (Figure 77).³³⁴ Arginine kinase, belongs to the ATP guanido phosphotransferase family, and is an enzyme present in insects and crustaceans. According to the WHO-IUIS allergen nomenclature committee until now 13 arginine kinases have been registered as allergens, 7 food allergens (crab (Cal b 2, Scy p 2), shrimp (Pen m 2, Cra c 2, Lit v 2), crayfish (Pro c 2), silk moth (Bomb m 1), 6 airway allergens (cockroach (Bla g 9, Per a 9), house dust mite (Der p 20, Der f 20), Indian meal moth (Plo l 1), and storage mite (Tyr p 20). Arginine kinases have a highly conserved amino acid sequence among various invertebrate species that are characterized by a β -sheet domain surrounded by α -helices.⁹¹⁷ No 3D structure of insect arginine kinase is currently available.

3 – Allergenic molecules (epidemiology including geography and function)

In UniProt many isoforms of tropomyosin (7566 entries) and arginine kinase (8754 entries) can be found. Of these, officially only silkworm (*Bombyx mori*) arginine kinase (Bomb m 1) and tropomyosin (Bomb m 3) are recognized by the WHO-IUIS (www.allergen.org) database as an insect food allergen.

Mealworms (*Tenebrio molitor*) were recently authorized by the European Commission as (novel) food for humans. IgE binding to many different proteins from mealworm was described, namely: tropomyosin, arginine kinase, paramyosin, chitinase, troponin C, myosin light and heavy chain, hexamerin, α -amylase, trypsin-like proteinase, cockroach-like allergen and larval cuticle protein. These proteins were identified using immunoprecipitation with serum from shrimp and mealworm allergic patients and LC-MS^{918,919} (Figure 78).

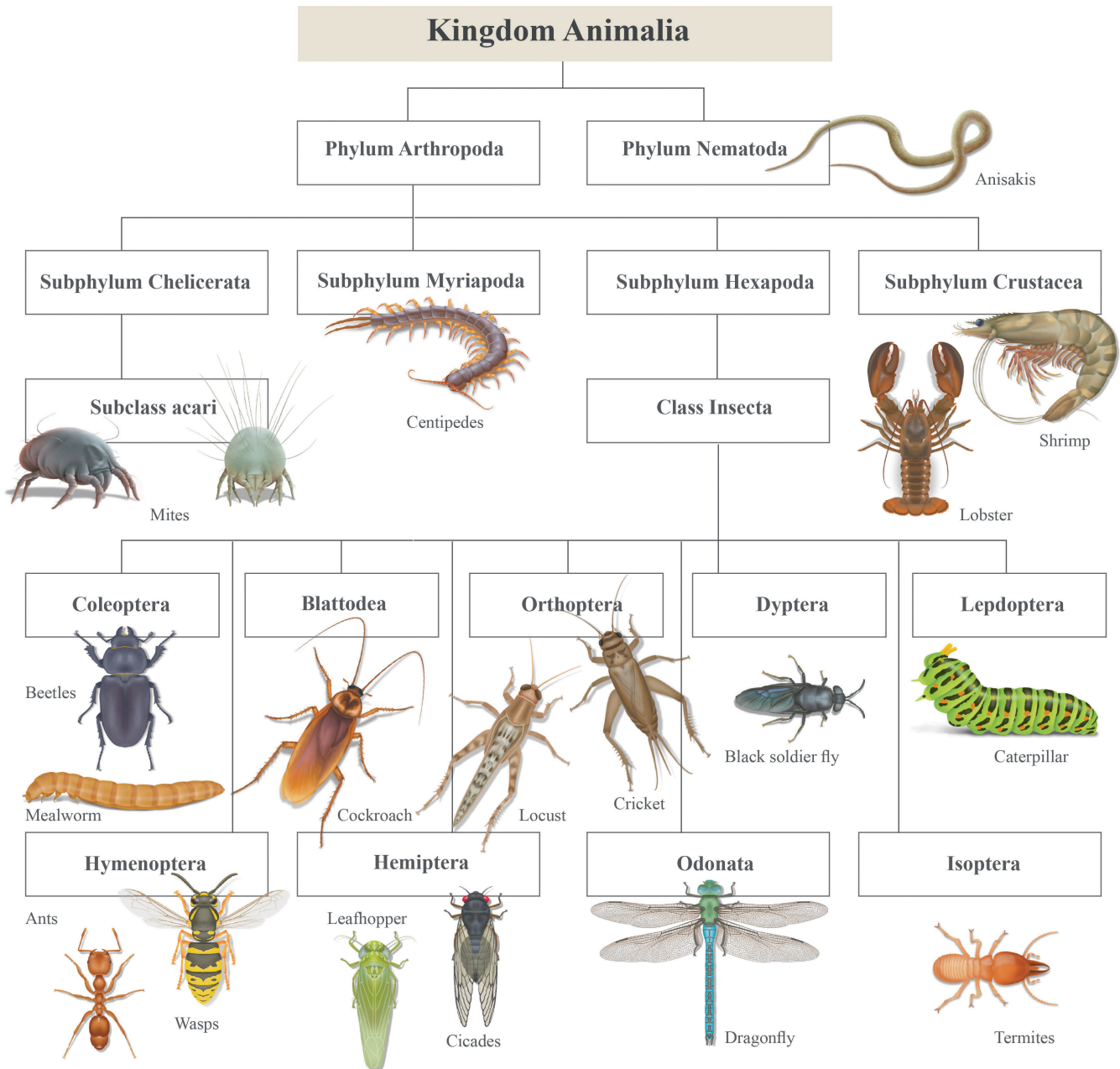


FIGURE 76 Simplified representation of the phylogenetic relationship between insects, mites, and crustaceans

Allergenic proteins were also reported for locust (*Patanga succincta*): arginine kinase, enolase, GAPDH, hexamerin and pyruvate kinase⁹²⁰; for cricket: arginine kinase, hexamerin-like protein 2, tropomyosin⁹²¹⁻⁹²⁴ and for Indian meal moth: arginine kinase.⁷⁵⁵ Table 31 only lists allergenic proteins where information on prevalence of IgE binding was previously reported.

Below the different putative allergens are briefly described. Tropomyosin is a muscle protein that, together with myosin and actin, is involved in muscle contraction.

Arginine kinase is an enzyme present in insects and crustaceans and contributes to cellular homeostasis by catalysing the transfer of phosphate between ATP and arginine.⁹²⁵

Other putative allergenic proteins in silkworms are paramyosin, chitinase⁹²⁶ and a 27-kDa glycoprotein.⁹²⁷ Paramyosin is a myosin filament-related protein found in the striated muscle of invertebrates, which plays an important role in the process of myosin filament assembly and mainly acts as a major muscle component in invertebrates. Paramyosin belongs to the paramyosin family. Paramyosin is known as an inhalation allergen in mites (Blo t 11, Der f 11, and Der p 11) and as a food allergen in Veined rapa whelk, *Rapana venosa*, a sea snail (Rap v 2) and *Anisakis simplex* (Ani s 2).

Chitinase belongs to the chitinase family (family 18 of glycoside hydrolases (GH18)) and is a component of the exoskeletal of

arthropods. Chitinase is a hydrolytic enzyme that breaks down glycosidic bonds in chitin.⁹²⁸ Allergenic chitinase (inhalant and food) can be found in mites (e.g., Der p 15) and in cockroach (Bla g 12 and Per a 12), fruits such as bananas (Mus a 2), pomegranate (Pun g 14) and avocado (Pers a 1) (see chapter B15).

Troponin C belongs to the troponin C family and is the calcium-sensing component of the troponin complex that can attach to and detach from tropomyosin. Troponin C is involved in muscle

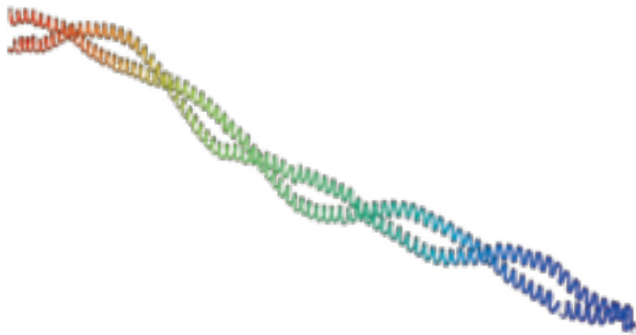


FIGURE 77 3D structure of tropomyosin from *Bombyx mori* (Q1HPU0 (TPM1_BOMMO), Q1HPU0 | SWISS-MODEL Repository (expasy.org))

contraction.⁹²⁹ Troponin C is also recognized as a food allergen in shrimp (Cra c 6 and Pen m 6). Myosin light and heavy chain belonging to the myosin family, are part of the sarcomeric units in muscle tissue. Myosin is involved in muscle contraction.⁹²⁹ Myosin light chain is also recognized as a food allergen in various shrimp species (Art fr 5, Cra c 5, Lit v 3, and Pen m 3).

Hexamerin belongs to the tyrosinase family, closely related to arthropod hemocyanins, is present in insect haemolymph as a storage protein and sometimes has a transporter function. In addition, hexamerin is incorporated in the cuticle and possibly involved in humoral immune defence.⁹³⁰ Alpha-amylase belongs to the glycoside hydrolase 13 (GH13) family and serves as a key digestive enzyme in most insects. Alpha-amylase hydrolyses starch into simple sugar units, which provides energy for survival and the development of insects.⁹³¹ Allergenic α -amylases can be found in mites (Der p 4, Der f 4), cockroach (Bla g 1, Per a 11), all inhalation allergens and as food allergens in barley (Hor v 16).

Trypsin like proteinase belongs to the proteases of the mixed nucleophile, superfamily A and is involved in protein digestion. Allergenic trypsin is mostly found in mites (Blo t 3, Der f 3, and Der p 3) as an inhalant allergen. Cockroach like allergen is a nitrile-specifier protein with a detoxifying function localized in the midgut

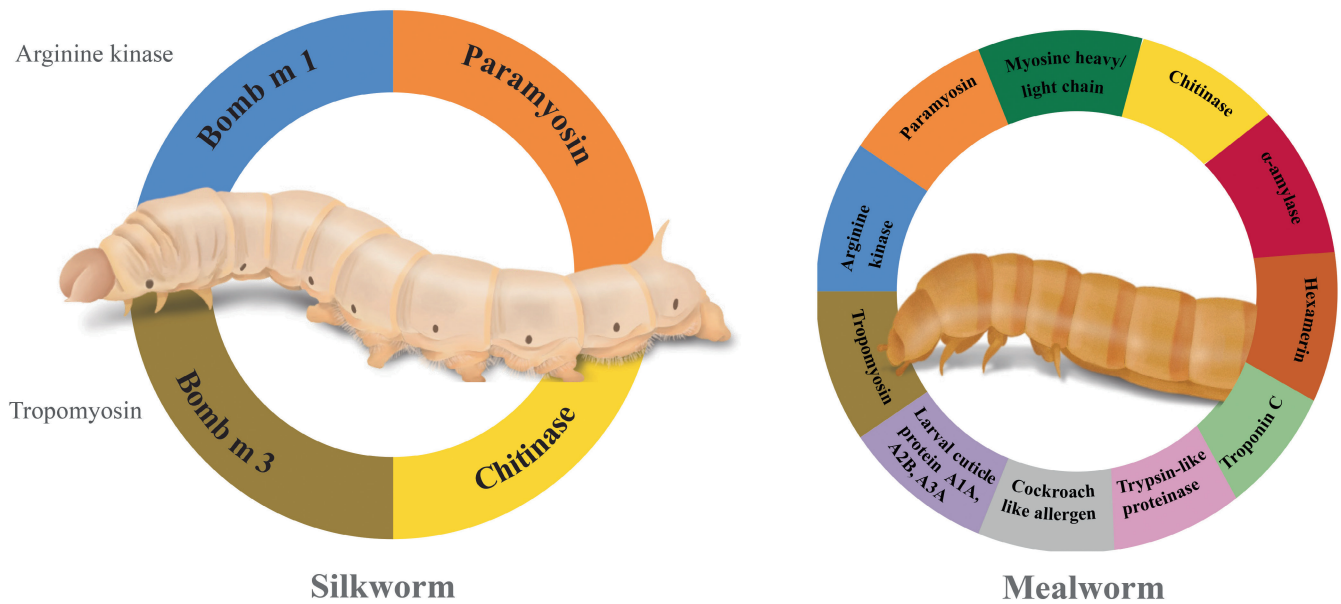


FIGURE 78 Allergen components from silkworm and mealworm. The same colour is used for related proteins.

TABLE 31 Relevant insect allergens *unpublished data

Species	Allergenic molecule	Protein family	Frequency of IgE	MW (kDa)
Silkworm	Bomb m 1	Arginine Kinase	100% (n=10) ¹⁷⁰⁵ [doi:10.1159/000210375]	42
<i>Bombyx mori</i>	Bomb m 3	Tropomyosin	53.3% (n=15) ¹⁷⁰⁶ [doi:10.3892/mmr.2017.6373]	38
Mealworm	NA	Arginine Kinase	23.1% (n=13)*	27
<i>Tenebrio melitor</i>	NA	Tropomyosin	76.9% (n=13)*	34
	NA	LCPAIA	100% (n=2) ⁹¹⁵	18

microvillar part of the insect. The cockroach allergen-like protein can only be found in the yellow mealworm (*Tenebrio molitor*). Larval cuticle protein (family unknown) is a mealworm specific protein, having a conserved domain in arthropod cuticles known as R&R consensus and binds chitin. The chitin-binding complex links the soft internal tissue to the exoskeleton of the larvae.⁹¹⁸

4 – Sensitization to individual molecules and their clinical relevance

Cross-reactivity/co-sensitization was assessed for mealworm, cricket, grasshopper, black soldier fly, moth, locust, termite, and cockroach with serum obtained from crustacean and/or house dust mite (HDM) allergic patients. The pan-allergens arginine kinase and tropomyosin were frequently involved in insect cross-reactivity between different insect species and crustaceans (e.g., shrimp) because tropomyosins and arginine kinases from different species are highly homologous (>70% sequence identity) (Figure 79). The sequence identity of other allergenic proteins from insects (e.g., paramyosin, chitinase) ranges from 35 to 90%.⁹³³ Unfortunately, the clinical relevance of this cross-reactivity has not been investigated.⁹³³

Only one study with 15 shrimp allergic patients showed clinically relevant co-sensitization of mealworm in 13 patients in a double-blind placebo-controlled food challenge (DBPCFC). All 15 patients were sensitized to mealworm extract (basophil activation test (BAT), the ImmunoCAP Specific IgE test and Western blot).⁹³⁴

Ten mealworm allergic patients had IgE against tropomyosin and 3 against arginine kinase (Table 31). These 15 patients had also sIgE

against House cricket, Giant mealworm, Lesser mealworm, African grasshopper, Large wax moth and Black soldier fly and this sIgE was able to activate basophils. Tropomyosin and arginine kinase were the most dominant allergens responsible for cross-reactivity between shrimp and the tested insects, but cross-reactivity to other allergens could not be excluded. It is most likely that shrimp allergic patients will react to various edible insects, but the clinical relevance needs to be further assessed.⁹³⁵ Primary sensitization to edible insects (mealworm) was demonstrated in two studies, within a total of 6 subjects, that all worked in a facility that reared or processed mealworms, which suggests exposure different from ingestion (e.g., inhalation or skin contact) and might have played a role in the onset of primary mealworm allergy as well.

Two employees, who worked in the production of yellow mealworm flour, complained after repetitive exposure to mealworm (rhinoconjunctivitis, itching and contact erythema) when entering the rearing room. Both subjects were used to eat edible insects such as wax moth, crickets and black soldier fly without any complaints. They experienced oral allergy syndrome (OAS) the first time eating a hamburger containing mealworms. Both patients refused to undergo a provocation test. The skin prick test for inhalant and food allergens were negative except for grass in subject 1 and *Alternaria* in subject 2. Specific IgE was found for mealworm extract but was negative for HDM and shrimp. The results indicate a primary food allergy to mealworm. The cockroach allergen like protein, early-staged encapsulation protein and troponin C were identified as responsible proteins.⁹³⁶

Another study showed that two mealworm breeders became food allergic to mealworm after repeated ingestion and exposure to mealworm (DBPCFC proven mealworm allergy) while two other

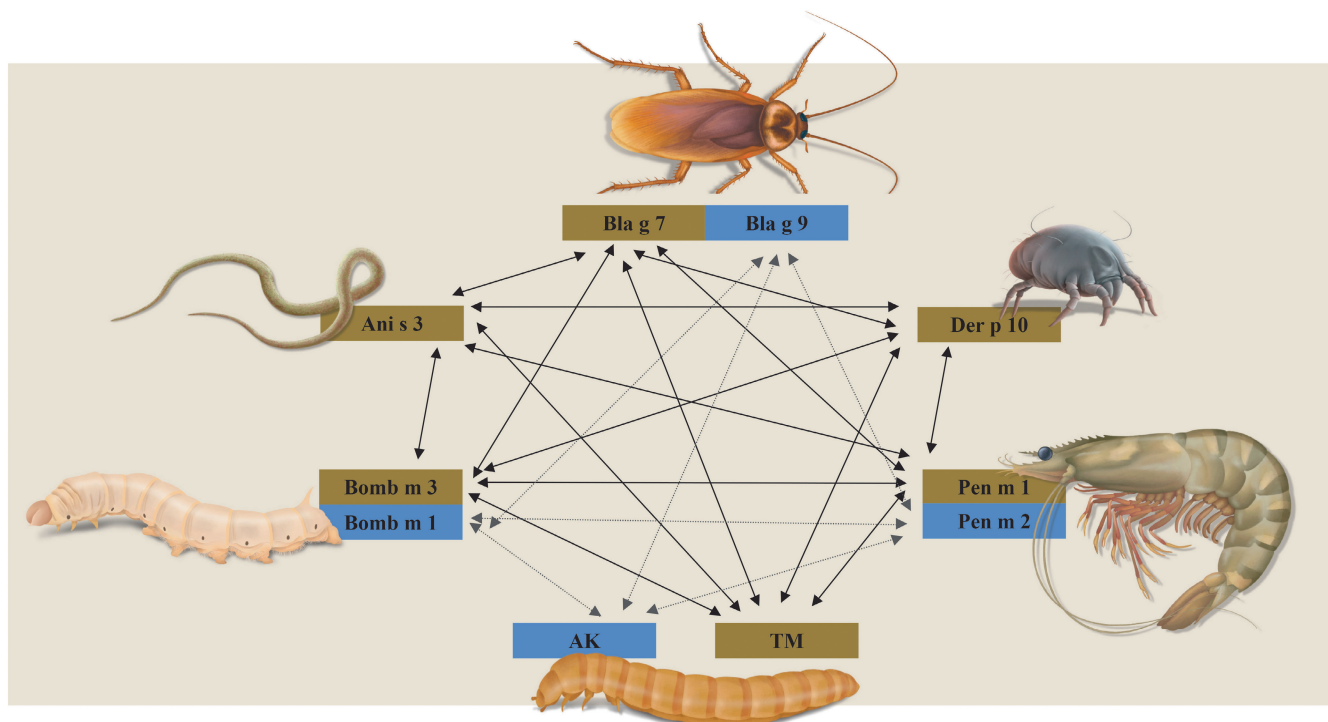


FIGURE 79 Cross-reactivity of tropomyosin (TM) and arginine kinase (AK) between different allergenic sources (Solid line=tropomyosin; dashed line=arginine kinase)

mealworm breeders only experienced complaints when working in the rearing facility. The mealworm food allergic breeders had higher sIgE to mealworm, consumed larger amounts of mealworm (~50 g), and were exposed for a longer period (7-9 years) than the two with respiratory allergy (~1 g mealworm and 2-5 years of exposure). This might suggest that occupational exposure for a longer period of time and/or oral exposure with high doses are required to develop a food allergy to mealworm. The mealworm allergic breeders were not allergic to shrimp (the open challenge was negative) or any other food, which suggested a primary food allergy to mealworm. The culprit allergens were the larval cuticle proteins A1A, A2B, and A3A.⁹¹⁸ The serum of the 4 mealworm allergic breeders had only sIgE against some of the tested insects (House cricket, Giant mealworm, Lesser mealworm, African grasshopper, Large wax moth, and Black soldier fly) and basophils' activation was not seen for all insects. This might suggest that primary mealworm allergy is not indicative of insect allergy and suggests the possibility of species-specific insect allergy when primarily sensitized to insect-specific proteins.⁹³⁵ This is confirmed by the fact that the mealworm allergic workers were able to eat wax moth, crickets and black soldier fly without any complaints.⁹³⁶

Insects intended for food formulations are necessarily subjected to postharvest processing, e.g., blanching, pasteurization, and sterilization to ensure their microbiological safety. It is well known that heat processing could affect the allergenic potency of proteins. Unfortunately, there is limited information concerning the effects of processing on the allergenicity of insects. Most studies investigated the effect on IgE binding, and the results are contradictory, possibly due to solubility issues.^{933,937} Furthermore, the impact of treatment on the IgE-binding capacity does not necessarily correlate with clinical symptoms. One study investigated the effect of thermal processing of mealworms on IgE-binding capacity and IgE cross-linking (basophil activation and skin prick test) and showed that processing did not lower IgE binding and functionality of mealworm allergens.⁹³⁸ Another study showed that both, thermal processing and hydrolysis using food grade enzymes of locust proteins abrogated the functionality of locust allergens in a skin prick test (n=5).⁹³⁹

5 – Clinical management

Diagnosis of insect food allergy is not routinely performed, because insects are seldom eaten in Europe and North America and diagnostic tests are not available yet.

The diagnosis of food allergy to insects has to start with a careful clinical history, followed by a prick-to-prick test or skin tests with commercial extracts (not yet available) and/or sIgE tests. Many insects can cross-react with shrimp/shellfish, so that it is advisable to include these in the evaluation (Figure 80).

In addition, sera can be tested for the presence of IgE to tropomyosin of the insect or to other (more or less related) species (e.g., shrimp, HDM, *anisakis*), because tropomyosins are very homologous amongst different species, a positive test could indicate cross-reactive insect food allergy to shrimp.

Availability of other individual allergens from insects is limited and can therefore not be used for the diagnosis of primary or secondary insect food allergy. Extracts of the whole insect can also be used to measure sIgE (ELISA, BLOT). A positive test could either indicate a cross-reactive or primary food allergy.

Ideally, a food challenge (open or DBPCFC) is performed with the suspected insect(s) to confirm or exclude food allergy. A food challenge with shrimp/shellfish should be considered to determine if insect allergy is cross-reactivity or a primary food allergy. In case of confirmation of food allergy to insect(s), elimination from the diet has to be advised and cross-reactive allergies need to be discussed (Figure 80).

6 – Clinical cases

Various case reports were described, reporting on food allergic reactions to different insects, e.g., (larvae of) beetles: mealworm, sago worm, lentil weevil, larvae of moths: silkworm, mopane worm, pine processionary caterpillar, woolly bear caterpillar, *Clanis bilineata*, and other insects such as locusts, crickets, grasshoppers, cicadas, and bees. Allergy was also reported following ingestion of carmine (E120), a colour additive, which is not a protein but a chemical pigment, obtained from female *Dactylopius coccus var. Costa*.⁹³³ Of all insects, allergy to silkworm (7 cases) and the food additive carmine (9 cases) were most frequently described. It is highly likely that not all clinical cases are described, so the prevalence of insect allergy is underestimated. Moreover, it can be expected that the prevalence of allergy to insects will increase, as the global consumption is increasing, due to the recent acceptance of mealworms to the European market. Below 3 cases of insect food allergy are highlighted.

Case 1⁹⁴⁰

Clinical History

A 47-year-old man experienced a severe allergic reaction, within 30 min anaphylaxis after the first consumption of approx. 5 grams of cricket (*Acheta domestica*) and mealworm (*Tenebrio molitor*) mixture. He developed nausea, erythema of the neck, cough and difficulty of breathing, requiring the use of antihistamines, corticosteroids and epinephrine followed by a 24-hour hospitalization. No co-factors, such as alcohol, NSAIDs, or exercise were reported by the patient. The patient reported, anaphylactic reactions occurring at the age of 20 and 24 years following consumption of crab, mussels, and ground snails. These reactions manifested as hives, gastrointestinal symptoms and breathing difficulties which led to practicing strict exclusion of all crustaceans, molluscs and gastropods from his diet.

Test with extracts

The patient had positive skin prick tests (SPT, not commercially available) to native cricket, mealworm, crab, mussel, and snail. Skin prick tests were also positive for shrimp despite the absence of any clinical reaction and negative for house dust mite (HDM). Specific IgE was positive to shrimp extract, and HDM. Reactivity was further investigated with basophil activation tests (BAT) with cricket,

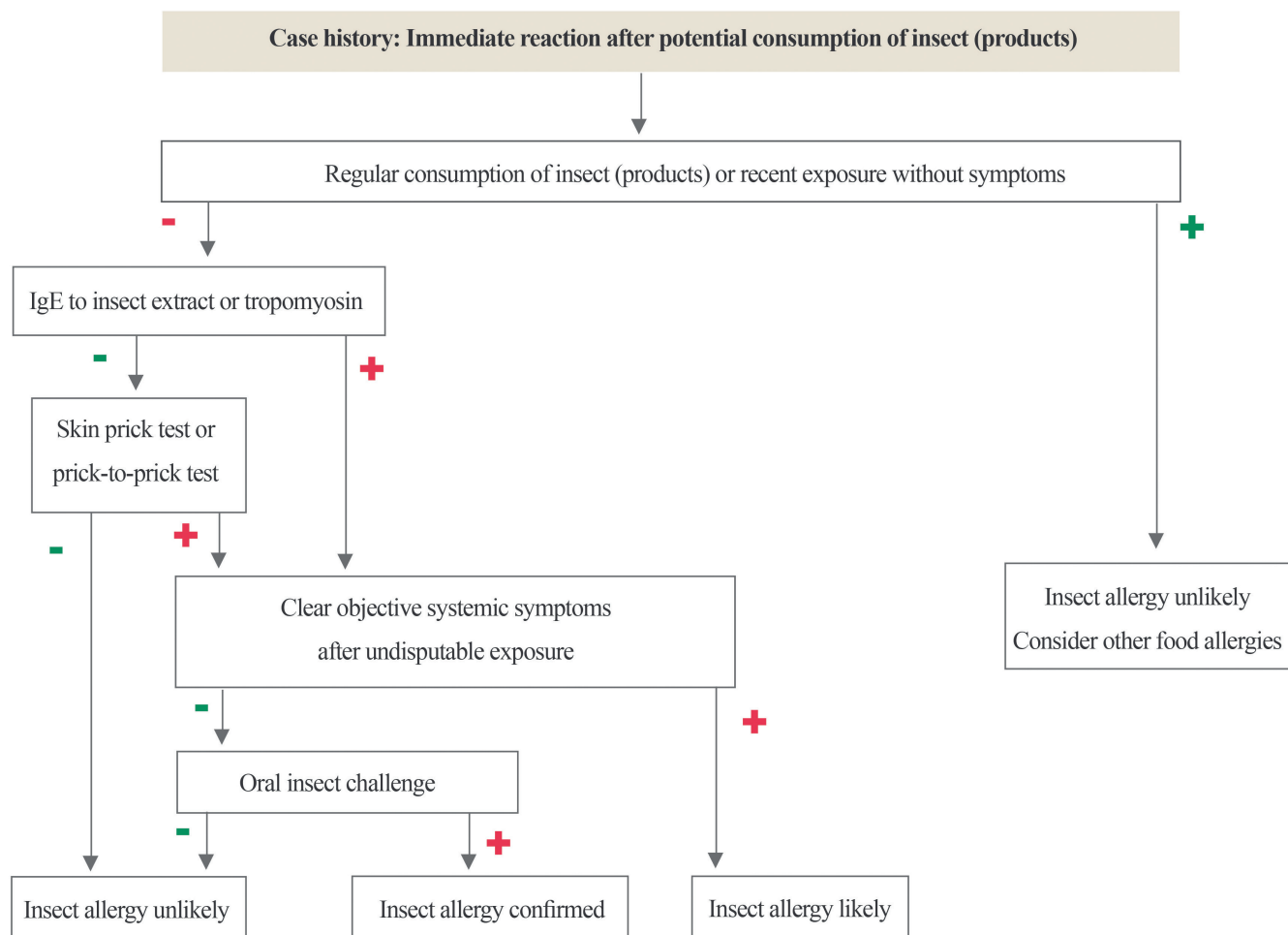


FIGURE 80 Diagnostic algorithm for insect food allergy

mealworm, shrimp, and snail extracts. All but shrimp extract induced basophil activation.

Food challenge

An open oral food challenge test was carried out with shrimp and was negative up to 100 g, excluding shrimp allergy.

Test with molecules

No sensitization to shrimp allergens Pen m 1 (tropomyosin), Pen m 2 (arginine kinase) or Pen m 4 (sarcoplasmic calcium-binding protein) was found with the ImmunoCAP ISAC allergen microarray. In addition, no IgE(s) to HDM, cockroaches or *Anisakis simplex* allergens was detected with ImmunoCAP ISAC.

Conclusion

Taken together, the data suggested that the occurrence of an anaphylactic reaction upon the first consumption of insect was explained by cross-allergy between crickets and mealworm, with mussel, crab, and snail, however, without the involvement of shrimp or HDM. In addition, the culprit allergen did not appear to be either tropomyosin, arginine kinase or the sarcoplasmic calcium-binding protein of crustaceans.

Case 2⁹²²

Clinical History

A 50-year-old woman experienced oral pruritus, oral itching, and oropharyngeal and lingual oedema after cricket ingestion. She could,

however, handle them in the kitchen without any problem. She also showed similar symptoms with the grasshopper. She ate scorpions, worms, and tarantulas without any symptoms.

Test with extracts

The patient had sIgE-positive for shrimp and against four cricket extracts: 0.6 kU/L for *G. assimilis*, *G. bimaculatus*, and *A. domesticus*, and 0.8 kU/L for *G. sigillatus*, *A. domesticus*, and *G. bimaculatus* being the species most frequently used in human food.

A skin prick test for *D. pteronyssinus* and *D. farinae* was positive, and so was a prick-to-prick test with shrimp head; however, a prick-by-prick test with shrimp body was negative. Prick-to-prick with four cricket species, including *Gryllus assimilis*, *Gryllus bimaculatus*, *Grylloides sigillatus*, and *Acheta domesticus* were also positive.

Food challenge

An oral provocation test with shrimp showed that she could safely eat them peeled.

Test with molecules

The patient's serum recognized a 75 kDa protein on the immunoblot, which was identified as hexamerin-like protein 2 with LC-MS.

Conclusion

The patient was food allergic to cricket and probably grasshopper but not to peeled shrimp. This is most likely due to sIgE against hexamerin-like protein 2, which is present in the shrimp head.

Case 3⁹⁴¹

Clinical History

A 15-year-old Zimbabwean boy experienced within 10 minutes headache, dyspnea, cough, wheeze, palatal pruritus, urticaria, tongue, and lip swelling after eating mopane worm, the larva of the emperor moth (*Imbrasia belina*). Symptoms gradually resolved after antihistamine use, but drowsiness persisted for 48 hours. The boy had eczema, which resolved after the age of 2 years. Since the age of 8 years, he had mouth and ear itching to mopane worm ingestion. Summer seasonal rhinitis started at the age of 3 years. He was neither asthmatic nor drug or latex allergic. His mother has allergic rhinitis, asthma, and oral allergy syndrome. Two siblings had a food allergy and allergic rhinitis, respectively. No long-term medications are used.

Test with extracts

Skin prick testing was positive for tree pollen (oak, Acacia), grass pollen (Bermuda, Timothy, maize), English plantain, dust mite mix (*Dermatophagoides farinae*, *Dermatophagoides pteronyssinus*), and cockroach (*Blattella germanica*). SPT results were negative to moulds, cats, and dogs. SPT with mopane worm was strongly positive (7 mm wheal and 15 mm flare).

A total IgE level of 622 kU/L was found. Positive the ImmunoCAP Specific IgE test results were as follows: *D. pteronyssinus*, 5.07 kU/L; *Anisakis*, 0.06 kU/L; tree mix, 0.06 kU/L; weed mix, 0.55 kU/L; grass mix, 4.98 kU/L; mealworm, 3.39 kU/L; *Schistosoma*, 0.59 kU/L; and *Ascaris*, 0.18 kU/L.

Food challenge

Not available.

Test with molecules

Allergen microarray test results (ImmunoCAP ISAC, Thermo Fisher Scientific, Uppsala, Sweden) were positive for the following: Bermuda grass (nCyn d 1): 23 ISU - Timothy grass (rPhl p 1): 4.6 ISU - Japanese cedar (nCry j 1): 1.7 ISU - cypress (Cup a 1): 14 ISU - *D. pteronyssinus* (nDer p 1): 2.3 ISU - *D. pteronyssinus* (nDer p 2): 2.8 ISU - *D. farinae* (rDer f 2): 3 ISU - olive (nOle e 2): 0.9 ISU - and latex (rHev b 8): 0.7 ISU.

Microarray test results were negative to foods (fruits, nuts, peanut, milk, egg, soybean, wheat, shrimp, codfish, carp), pollens (plane, ragweed, mugwort, saltwort), tropomyosin in shrimp (rPen a 1, nPen i 1, nPen m 1), *D. pteronyssinus* (rDer p 10), cockroach (nBla g 7), and *Anisakis simplex* (rAni s 3). Western blot with mopane worm extract showed a positive band at 50 kDa, which was not identified.

Conclusion

The results of both SPT and Western blot to MW were positive, confirming sensitization. sensitization to dust mites (SPT, ImmunoCAP Specific IgE and ImmunoCAP ISAC tests), cockroach (SPT), *Ascaris* (the ImmunoCAP Specific IgE), and *Anisakis* (ImmunoCap RAST and Western blot) suggest a cross-sensitization. This may result from glutathione transferases or tropomyosin, which have been implicated in cross-reactivity among *Ascaris*, dust mites, cockroaches, crustaceans, and molluscs.

7 – Research and future perspectives

Currently only allergens (tropomyosin and arginine kinase) from silkworms are recognized by the WHO-IUIS (www.allergen.org) database as a food allergen, while more and more evidence is available that also other insects contain putative food allergens. In addition to tropomyosin and arginine kinase, other proteins might be involved.

Clinically relevant IgE binding and cross-reactivity was only found for mealworm in shrimp allergic patients. Unfortunately for other insects, no data are available yet.

None of the case reports found confirmed the food allergy to insects with a food challenge.

Mealworms were recently approved by the EU Commission as a novel food. Allergic patients and their health care providers should be informed about the possible risk the introduction of insect proteins might pose and labelling of mealworm allergens should be required by authorities. Not only cross-reactive risk may be expected but also primary food allergy caused by insects may occur.

Most studies investigated shrimp allergic and HDM allergic patients with IgE to tropomyosin but also 22% of the HDM allergic patients without tropomyosin, arginine kinase or shrimp sensitization and 16% of a seasonal rhinitis population showed mealworm-protein reactive IgE. Although a higher prevalence of sensitization to mealworm was found in the population of shrimp allergic patients (88%), HDM allergy and seasonal rhinitis are much more prevalent.⁹⁴² The clinical relevance of this IgE binding should therefore be investigated. It should be noted that sensitization to mealworm in the seasonal rhinitis and HDM allergic populations could be caused by cross-reactivity to other insects. Such primary sensitization may result from historical exposure to insect proteins. We are all exposed to insect allergens, both aerosolized and as food contamination. Primary allergy to mealworms was also demonstrated. In theory, besides the development of such primary insect allergy, cross-reactive allergies might develop leading to broader insect-protein sensitization and allergy. Reasoning the other way around, theoretically, primary insect allergy could lead to the development of cross-reactive allergy to shrimp or HDM. This should be investigated in the future for instance by post-launch monitoring. Post-launch monitoring would help to identify new allergies when novel (insect) foods will enter the food market and to increase awareness in patients at risk and their caregivers.

Advices for use of molecular diagnostics for insects

1. Specific IgE to tropomyosins of different species (Shrimp, HDM and *Anisakis*) is a marker for potential sensitization and (cross)allergy to insects.
2. Different extraction buffers should be used to extract as many proteins from insects as possible for a good diagnosis of insect sensitization.

B10 – Cow's milk allergy

Anna Nowak-Wegrzyn, Rebecca Grohman, Antonella Muraro

Highlights

- Cow's milk allergy is the most common food allergy universally and is often outgrown.
- The utility of IgE to allergen components does not exceed that of IgE to cow's milk extract to support the diagnosis of cow's milk allergy.
- Sensitization to heat-resistant proteins (e.g., casein) and sequential epitopes have been associated with reactivity to baked milk and persistent milk allergy.

1 – The allergen sources

Cow's milk (CM) is a liquid product of the mammary glands of cow's (*Bos domesticus*). It is commonly consumed in large quantities by children and adults in a liquid form, as well as in a form of various dairy products, such as cheeses, butter, yogurt, and cream. CM is a base source for the majority of infant formulas, including hypoallergenic hydrolyzed and amino acid-based formulas. CM is commonly the first foreign protein introduced into the diet of infants who are not exclusively breast-fed. CM and dairy products are the major source of protein, calories, and calcium in a diet of infants and young children under the age of 2 years, and elimination of CM poses a risk for nutritional deficiencies. CM proteins are among the most common food allergens in infant and children with IgE and non-IgE-mediated food allergy, and among adults with eosinophilic esophagitis. The frequency of CM allergy has been estimated to range from 0.5 to 7.5% in westernized countries.^{73,74,940,941} Nevertheless, the perceived prevalence of allergic reactions to CM milk is much higher than the actual number of true cases of CM allergy. CM proteins are classified as class I food allergens, due to their resistance to digestion and heating. They do induce sensitization via gastrointestinal tract. Proteins in CM have a high sequence homology (>80%) with proteins from goat and sheep and are highly clinically cross-reactive (>90%) with these species. By contrast, the laboratory and clinical cross-reactivity is very low (<5%) with milks from donkey, mare, buffalo, or camel.⁹⁴²

2 – Major and relevant minor allergenic molecules

CM contains approximately 30 to 35 g of proteins per liter. Under the influence of rennin or upon acidification of the milk to pH 4.6, proteins segregate into 2 fractions: casein which contains approximately 80% of the CM proteins and whey (lactoserum) which contains approximately 20% of the CM proteins (Table 32). All of the proteins present in cow's milk are also present in human breast milk, with an exception of beta-lactoglobulin. Caseins, beta-lactoglobulin

and alpha-lactalbumin are considered major allergens, i.e., more than 50% of the individuals with CMA are sensitized to these proteins. Most of the patients are polysensitized to several proteins.^{943,944}

Casein supplies amino acids, carbohydrates, and the two inorganic elements calcium and phosphorus. Casein fraction is very resistant to high temperatures, retaining strong IgE binding after 90 minutes of boiling at >90°C.⁹⁴⁵ Except for short alpha-helical regions, caseins have little secondary or tertiary structure.^{946,947} The caseins of cow's milk exist in the form of colloidal complexes called micelles. The micelles contain an amorphous micellar calcium phosphate core, surrounded by a casein shell.^{946,947} (Figure 81, from ref 10).⁹⁴⁷

Alpha_{s1}-casein is the most abundant protein of bovine milk. It exists as a major and minor form and is highly phosphorylated. Alpha_{s2}-casein is also highly phosphorylated and has four isoforms. Beta-casein has one isoform. Limited hydrolysis of beta-casein by endogenous peptides (e.g., plasmin) present in milk produces gamma-caseins 1, 2, and 3. Kappa-casein is the only casein soluble in the presence of calcium ions. It also has the smallest amount of phosphate, with phosphorylation sites being present only in the C-terminal region. Kappa-casein is the only casein to contain carbohydrate moieties.

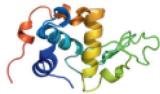

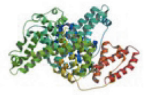

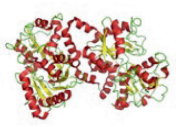
Whey is a mixture of beta-lactoglobulin (~65%), alpha-lactalbumin (~25%), bovine serum albumin (~8%) and immunoglobulins.⁹⁴⁸ These are soluble in their native forms, independent of pH. Whey proteins are more sensitive to heating than caseins and lose IgE binding following 15–20 minutes of boiling at >90°C.⁹⁴⁵

Alpha-lactalbumin is a protein present in the milk of almost all mammals. In primates, alpha-lactalbumin expression is upregulated in response to the hormone prolactin and increases the production of lactose.⁹⁴² Alpha-lactalbumin forms the regulatory subunit of the lactose synthase (LS) heterodimer and beta-1,4-galactosyltransferase forms the catalytic component. Together, these proteins enable LS to produce lactose by transferring galactose moieties to glucose. As a multimer, alpha-lactalbumin strongly binds calcium and zinc ions and may possess bactericidal and / or antitumor activity.

Beta-lactoglobulin under physiological conditions forms dimers but dissociates to a monomer below pH 3. Beta-lactoglobulin solutions form gels in various conditions, when the native structure is sufficiently destabilized to allow aggregation.⁹⁴³ No clear function has been identified for beta-lactoglobulin, although it binds to several hydrophobic molecules, suggesting potential role in their transport. Beta-lactoglobulin is the only CM protein that is not present in the human breast milk.

Bovine serum albumin (BSA) is a globular, water-soluble, unglycosylated serum protein. Albumin functions primarily as a carrier protein for steroids, fatty acids, and thyroid hormones in the blood and plays a major role in stabilizing extracellular fluid volume by contributing to oncotic pressure of plasma. BSA is highly homologous with human serum albumin and albumins of other species, e.g., cow (beef), cat, and dog. BSA has been identified as one of the major beef allergens and is responsible for clinical cross-reactivity between CM and raw beef.^{948–951} Immunoglobulins present in CM are predominantly of the G class. Immunoglobulins may play a role in cross-reactivity with beef.⁹⁴⁹

TABLE 32 Allergens in Cow's Milk (source: IUIS Allergen Database, July 2015)

Protein name	Allergen name	Molecular mass (kDa)	AA #	Tertiary structure
Curd (coagulum) - Casein family				
Caseins	Bos d 8	20-30		Caseins don't have a rigid tertiary structure but develop a random coil conformation stabilized by hydrophobic interactions
Alpha s1-casein	Bos d 9	23.6	199	
Alpha s2-casein	Bos d 10	25.2	207	
Beta-casein	Bos d 11	4	209	
Kappa-casein	Bos d 12	19	169	
Whey (lactoserum)				
Alpha-lactalbumin	Bos d 4	14.2	123; 4 disulphide bridge, 70% homology with human alpha-lactalbumin	
Beta-lactoglobulin Protein family: lipocalins	Bos d 5	18.3; exists as a dimer	162; 2 disulphide bridges, one free cysteine; exists as isoforms A and B; binds and carries hydrophobic molecules	
Bovine serum albumin; Serum albumins	Bos d 6	67	583	
Immunoglobulins (mostly IgG) Family: Immunoglobulins	Bos d 7	160		
Lactoferrin Family: Transferrins		80	703; forms two homologous globular domains named N-and C-lobes Lactoferrin exists in various polymeric forms: monomers to tetramers xac	

Lactoferrin is a multifunctional protein of the transferrin family. Lactoferrin is a globular glycoprotein with a molecular mass of about 80 kDa that is widely represented in various secretory fluids, such as milk, saliva, tears, and nasal secretions. Lactoferrin is one of the transferrin proteins that transfer iron to the cells and control the level of free iron in the blood and external secretions. Lactoferrin is one of the components of the immune system of the body; it has antimicrobial activity (bactericide, fungicide) and is part of the innate immune defense, mainly at mucosal surfaces. In particular, lactoferrin provides antibacterial activity to human infants. Lactoferrin interacts with DNA and RNA, polysaccharides and heparin. Lactoferrin is a minor allergen in CM.⁹⁴⁴

3 – Sensitization to individual molecules and its clinical relevance

The patterns of sensitization to the individual CM proteins vary significantly by study population and age of the affected individuals. In general, most of the affected subjects are polysensitized to

several casein and whey proteins. Caseins, beta-lactoglobulin and alpha-lactalbumin are the major allergens, with over 50% of CM-allergic subjects having evidence of IgE antibodies directed at these proteins. IgE sensitization to caseins, beta-lactoglobulin and alpha-lactalbumin is closely related, whereas IgE sensitization to BSA is independent of other CM proteins, and may reflect cross-reactivity with beef.⁹⁴⁹ (Table 33).

Effect of heating on CM protein allergenicity

CM proteins contain both conformational and sequential IgE-binding epitopes. Children with persistent milk allergy have been shown to predominantly generate IgE antibodies directed against sequential casein epitopes.^{952,953} Extensive heating e.g., baking, affects the allergenicity of CM protein, with caseins being more resistant to heating compared with whey proteins that are susceptible to heating. Heating of beta-lactoglobulin results in formation of the intermolecular disulphide bonds and binding to other food proteins that result in a reduced allergenicity of beta-lactoglobulin.⁹⁵⁴ The majority (70-80%) of the CM-allergic children tolerate CM as an ingredient in the baked products.^{385,954} Reactivity to baked milk is a marker of a more severe and more persistent CM allergy. Inclusion

of the baked products containing CM into the diet of children with CM allergy is associated with more rapid advancement to inclusion of liquid milk, but there is no conclusive evidence that it accelerates development of tolerance to unheated CM.⁹⁵⁵ High levels of specific IgE antibodies directed against casein are predictive of clinical reactivity to baked milk.^{956,957} In a peptide microarray assay, subjects with persistent milk allergy had increased epitope diversity to caseins and beta-lactoglobulin compared with those who outgrew their CM allergy.⁹⁵⁸ Baked milk-tolerant subjects had IgE-binding

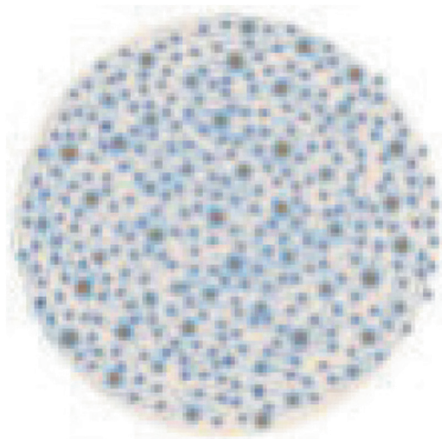


FIGURE 81 Casein supplies amino acids, carbohydrates, and the two inorganic elements calcium and phosphorus. Casein fraction is very resistant to high temperatures, retaining strong IgE binding after 90 minutes of boiling at $>90^{\circ}\text{C}$ ⁹⁵⁰. Except for short alpha-helical regions, caseins have little secondary or tertiary structure^{951,952}. The caseins of cow's milk exist in the form of colloidal complexes called micelles. The micelles contain an amorphous micellar calcium phosphate core, surrounded by a casein shell^{951,952}. (Figure from ref⁹⁴⁷).

patterns similar to those who had outgrown CM allergy, but IgG4-binding patterns that were more similar to those of the allergic group. Binding to higher numbers of IgE peptides was associated with more severe allergic reactions during an oral CM challenge. There was no association between IgG4 peptides and clinical features of milk allergy. Using a competitive peptide microarray assay, CM-allergic patients had a combination of high- and low-affinity IgE binding, whereas baked milk-tolerant subjects and those who had outgrown their CM allergy had primarily low-affinity binding.

4 – Clinical management

Diagnosis of CM allergy begins with an assessment of clinical history and an assessment of the potential immunologic mechanism involved in the reactions.

Suspected IgE-mediated CM allergy

Diagnostic testing: Routine testing involves skin prick (SPT) and/or serologic testing with complete CM extract. Molecular diagnosis is not recommended for standard evaluation of suspected CM allergy. Diagnostic decision points have been proposed; they vary by population studied and age. Negative SPT and undetectable serum level of CM-specific IgE antibodies have a very high negative predictive value $>90\%$ for IgE-mediated CM allergy. The positive predictive value of the test increases with an increased size of the wheal of the SPT and serum level of the specific CM-IgE antibody (Table 34).

Molecular diagnosis may be helpful for evaluation of reactivity to baked milk, based on the differential resistance to heating among the CM protein. As caseins are more resistant to extensive heating, higher levels of casein-specific IgE are associated with increased likelihood of reactivity to baked milk. Basophil activation test with CM proteins has been utilized in a research setting, but it is not yet recommended for a routine diagnosis of CM allergy.^{956,959}

TABLE 33 Sensitisation and cross-reactivity patterns of the CM proteins

Allergen name	Allergenicity	Sensitisation rate % among those reactive to CM	Laboratory cross-reactivity	Clinical cross-reactivity
Curd (coagulum) - Casein family				
Caseins (Bos d 8)	Major	63	>85% with sheep and goat milk caseins	>90%
Alpha s1-casein (Bos d 9)	Major	98 *		
Alpha s2-casein (Bos d 10)	Major	94 *		
Beta-casein (Bos d 11)	Major	91 *		
Kappa-casein (Bos d 12)	Major	91 *		
Whey (lactoserum)				
Alpha-lactalbumin (Bos d 4)	Major	51	80% with beef	15-20% with raw beef
Beta-lactoglobulin (Bos d 5)	Major	61		
Bovine serum albumin (Bos d 6)	Minor	43		
Immunoglobulins (Bos d 7)	Minor	36		
Lactoferrin	Minor	35		

TABLE 34 Proposed specific IgE diagnostic decision points for CM allergy diagnosis derived from studies in children, majority of whom had atopic dermatitis. This might be a practical guidance for the clinical ambulatory setting, aiming to identify the optimal candidates for OFC and to limit unnecessary OFC. It would however be recommended that specific values are developed for the local population. It is important to recognize that OFC can always be performed at the discretion of the treating physician despite the elevated results of the allergy tests. In the research setting, DBPCFC OFC are recommended regardless of the CM-sIgE level.

	CM-sIgE [kUA/L]	OFC to unheated milk
>95% PPV	≥ 15 ; ⁵² ≥ 5 if less than 1 year old ⁵³	Defer
>50% to <95% PPV	5-15	Consider the OFC based on the clinician and patient's/family preference, social and nutritional importance of dairy, history of recent reactions and type of symptoms
<50% PPV	<5 CM skin prick test mean wheal diameter, mm	Perform
>95% PPV	≥ 8 ⁵⁴ Casein-sIgE [kU/L]	OFC to baked milk
>95% PPV	≥ 10 ²¹	Defer
>50% to <95% PPV	5-10	Consider the OFC based on the clinician and patient's/family preference, social and nutritional importance of dairy, history of recent reactions and type of symptoms
<50% PPV	≤ 5 ²¹ CM skin prick test mean wheal diameter, mm	Perform
>90 NPV	<12 ⁵⁵ Casein skin prick test mean wheal diameter, mm	Perform
>90% NPV	≤ 9 ⁵⁵	Perform

Not recommended: Testing for CM-specific IgG / IgG4 antibodies is not recommended in the diagnosis of CM allergy as these antibodies reflect the presence of CM in the diet, not an allergy.

Elimination-Challenge testing: In general, the conclusive diagnosis of CM allergy requires elimination of CM proteins from the diet followed by a supervised oral food challenge. Double-blind placebo controlled oral food challenge (DBPCFC) remains the gold standard for food allergy diagnosis and it is commonly utilized in the research setting. Open controlled challenge can replace DBPCFC in the children younger than 2 years of age and serve as a useful screening

test for patients of any age in the clinical setting. The initial assessment of reactivity to baked milk is also recommended to be conducted under the physician-supervised food challenge condition because children reactive to baked milk may experience anaphylaxis. However, such approach may be unnecessarily restrictive and not practical when access to food challenges is limited due to the paucity of allergy specialists or during the COVID-19 pandemic.⁹⁶⁰ Several reports indicated that home introduction of baked milk and egg may be safely done in carefully selected young children, e.g., under the age 3 years, without prior history of anaphylaxis or wheezing from any causes and skin prick test wheal diameter less than 8 mm for cow's milk.^{961,962} Home introduction starts from a significantly lower dose of baked milk and progresses slowly over the course of days as compared to a single supervised feeding over hours to a higher dose of baked food. However, severe and even delayed reactions are possible and caution is needed.^{963,964} The implementation of this approach must be adapted to the local context including quick access to emergency facilities, if required.

Suspected non IgE-mediated CM allergy

Laboratory testing: There is no reliable laboratory diagnostic testing for non-IgE-mediated CM allergy.^{74,944} Atopy patch testing may be considered in selected cases of EoE but not as a routine diagnostic test.⁷⁴ Lymphocyte transformation test, serum CM-specific IgG / IgG4 antibodies, or stool measurements of pro-inflammatory mediators (e.g., calprotectin, eosinophilic cationic protein, eosinophil derived neurotoxin) are not recommended [1]. As some non-IgE-mediated disorders may be associated with a concomitant IgE-mediated food allergy, testing for CM-specific IgE antibodies may be utilized in such cases, e.g., eosinophilic esophagitis (EoE) and food protein-induced enterocolitis syndrome (FPIES) to diagnose IgE-mediated CM allergy. The ultimate confirmation of diagnosis in non-IgE-mediated CM allergy requires an elimination of CM proteins from the diet and followed by an oral CM challenge. With an exception of FPIES, reintroduction of CM can be done at home. When FPIES is suspected, reintroduction during a supervised food challenge should be considered, due to the risk of severe reactions (hypotension). Tolerance to baked milk among patients with non-IgE-mediated CM allergy has not been systematically characterized. Based on anecdotal reports, a subset of patients with EoE might tolerate baked milk in the diet; however, such patients likely represent a minority, unlike with IgE-mediated CM allergy.

Management of CM allergy

Management primarily relies on dietary avoidance of CM proteins. However, emerging data emphasize a shift from the traditional passive approach of avoidance, to a proactive one that seeks to modulate the immune system.⁹⁶⁵ In infants and young children, substituting alternative sources of protein, calories, and calcium with a specialized hypoallergenic formula may be necessary. The alternative formula choices include casein-hydrolysate, whey-hydrolysate, and amino-acid based formulas, as well as soy-based and rice hydrolysate.⁹⁶⁶ The selection of the most appropriate formula depends on the age and allergic profile of the child. Soy formulas are based on an intact protein and are not hypoallergenic but can be a suitable

alternative to cow's milk. Soya milk should be used with caution, especially in younger infants with gastrointestinal manifestations as they are at risk of reacting to soya when this is introduced in place of cow's milk via an inflamed gut. In non-IgE-mediated food allergy, co-reactivity between cow's milk and soya in the first 6 months of life is about 40%. Nutritional consultation is recommended for those with severe form of CM allergy, multiple food allergies and poor growth. Multiple studies of CM allergy have shown that avoidance of CM compared with avoidance of other allergens resulted in greater deficits in height and weight.⁹⁶⁷ Education about recognition of allergic symptoms and prompt treatment of anaphylaxis is crucial in the patients at risk for anaphylaxis. As most children outgrow CM by school age, periodic re-evaluations every 6-12 months with laboratory testing and oral food challenges are recommended. A drop in the specific CM IgE level by 50% or more over 12-24 months is a favorable prognostic indicator of developing tolerance.⁹⁶⁸ Basophil activation tests, in combination with serum specific IgE and SPT, can also help identify patients that have developed tolerance to CM.¹⁸¹ Children with peak lifetime CM-IgE >50 kU/L are more likely to retain milk allergy until teenage years and may need less frequent testing.⁹⁶⁹ Introduction of baked products with CM should be attempted under physician supervision for patients with IgE-mediated FA. Baked milk products may be tolerated by a subset of patient with EoE.⁹⁷⁰ It is unknown if children with FPIES can tolerate baked milk products and therefore strict avoidance is recommended.

Cross-reactivity with beef and oligosaccharide galactose- α -1,3-galactose (α -gal) syndrome

The prevalence of beef allergy among those with CM allergy has been estimated as 13-20%.⁹⁷¹ Conversely, the prevalence of CM allergy among those with beef allergy is considerably higher. In a double-blind placebo-controlled food challenge study of 335 patients with atopic dermatitis (AD) and possible food hypersensitivity, 11 were found to have symptomatic beef allergy, 8 (73%) of which were also sensitive to CM. Mammalian meat allergy or α -gal syndrome is a recently identified delayed food allergy associated with tick bites, leading to the development of IgE to the α -gal. Many patients with α -gal syndrome have IgE antibodies that recognize α -gal present in CM extract and have positive SPT to CM. However, avoidance of dairy products is not routinely recommended in these patients, as most patients are able to tolerate CM or cheese.²⁰ In a study of 24 patients with IgE to α -gal, 14/24 participants showed tolerance to CM despite positive skin prick test and serum titers. While avoidance of mammalian meat is recommended in α -gal syndrome, avoidance of cow's milk is not always required, in patients with clinical tolerance of CM.⁹⁷²

Natural history of CM allergy

CM allergy is the most common childhood allergy with a prevalence estimated of 2.5% including both IgE and non-IgE-mediated reactions.^{969,973,974} Sensitization typically occurs within 1 year of age. Multiple prospective and retrospective observational cohort studies in the US, UK and Israel have estimated the rates of resolution to be approximately 50% by age 10.⁹⁷⁵ A study of 244 with CM allergy by

Wood et al found resolution at 52.6% at median age of 63 months, with CM-IgE, milk SPT wheal size and AD severity as important predictors of prognosis.⁹⁷⁶ Skripak et al reviewed 807 patients with CM allergy and estimated rates of resolution at 4, 8, 12, and 16 years to be 19%, 42%, 64% and 79% respectively. Those with persistent CM allergy had higher CM-IgE levels up until 16 years of age and those with concurrent asthma and allergic rhinitis were associated with worse outcomes.⁹⁶⁹ Other studies have shown faster rates of tolerance. A Danish birth cohort of 1749 children with CM allergy showed tolerance in 56% at 1 year and 77% at 2 years.⁹⁷⁷ Resolution in non-IgE-mediated CM allergy have been shown to occur more rapidly compared with IgE-mediated CM allergy. The EuroPrevall birth cohort study found that tolerance at 1 year occurred in 100% of those with non-IgE CM allergy, compared with 57% in those with IgE-mediated CM allergy. In contrast to childhood CM allergy, adult onset of IgE-mediated CM allergy is rare but characterized by more severe reactions including anaphylaxis that occur with low eliciting doses starting at 0.3 mg CM protein.⁹⁷⁸

Prevention of CM allergy

Early introduction of peanut and egg has been now established in the prevention of peanut and egg allergies, especially in population with high prevalence of the disease.⁹⁷⁹ However, the evidence has been less clear with regards to CM ingestion. A recent review article of very early CM introduction within the first month of life discussed three observational studies associated with decreased incidence of CM allergy.⁹⁷⁵ A randomized control of 491 infants showed that daily ingestion between 1-2 months of age of at least 10 mL of CM formula reported 2 CMA cases (0.8%) among the 242 members of the ingestion group and 17 CMA cases (6.8%) among the 249 participants in the avoidance group (risk ratio = 0.12; 95% CI = 0.01-0.50; P < .001). The risk difference was 6.0% (95% CI = 2.7-9.3%).⁹⁸⁰ This is an area ongoing area of research that may impact future consensus guidelines on timing to introduce CM.

Novel therapies for CM allergy

Oral (OIT), sublingual (SLIT) and epicutaneous (EPIT) immunotherapy routes have been evaluated for CM allergy with promising results in clinical trials.^{981,982} OIT, SLIT, and EPIT utilize native CM proteins in a form of a CM powder. In a trial comparing CM OIT and SLIT, 10% receiving SLIT (maintenance daily dose 7 mg CM) were desensitized, 60% receiving SLIT/low dose OIT (maintenance daily dose 1000 mg CM) were desensitized, and 80% receiving SLIT/high dose OIT (maintenance daily dose 2000 mg CM) were desensitized.⁴⁰⁵ In general, CM SLIT was associated with very mild side effects mostly oro-pharyngeal pruritus, whereas CM OIT was associated with more systemic side effects, involving gastrointestinal tract (nausea, vomiting, abdominal pain, diarrhea), or respiratory system (rhinorrhea, sneezing, congestion, cough, wheezing).³⁸³ CM OIT has been associated with cases of EoE. More studies are needed to determine the potential of inducing permanent oral tolerance to milk with CM OIT. In a small pilot study, after 90 days, CM EPIT treatment tended to increase the cumulative tolerated dose, from a mean \pm SD of 1.77 \pm 2.98 mL at day 0 to 23.61 \pm 28.61 mL at day 90.⁹⁶⁷

5 – Clinical cases

Case 1:

Parents of a 2-year old child with atopic dermatitis and history of milk-induced generalized urticaria at the age 6 months inquire about the likelihood of their child outgrowing milk allergy. There are no additional allergic reactions to milk or milk products. Skin prick test with a commercial cow milk extract is positive at a mean wheal diameter at 10mm. Serum CM-specific IgE antibody level is 17 kU/L. Based on these results, the child has more than 95% chances of reacting to liquid milk. However, considering that about 70-80% of milk allergic children tolerate milk in the baked products, further diagnostic testing is performed. Serum specific IgE antibodies directed against casein level is 4.5 kU/L and beta-lactoglobulin IgE is 25 kU/L. Based on the level of the casein-specific IgE, it is estimated that the

likelihood of tolerating baked milk products in form of a muffin is approximately 50%. A physician-supervised oral challenge with baked milk in a form of a muffin is performed in the office and the child tolerates it without an adverse reaction. Baked milk products are incorporated into the diet.

Case 2:

A 10-year-old asthmatic male has history of severe anaphylaxis to trace amounts of milk in a cookie. He wants to know what his chances of outgrowing his milk allergy are His CM-IgE is 75 kU/L, casein IgE is 90 kU/L; SPT to CM extract is 20mm diameter. Based on his past history of anaphylaxis to baked milk and the current test results highly predictive of clinical reactivity to both baked and unheated milk, it is likely that he will remain-milk allergic until his teenage years.

B11 - Allergy to egg

Mattia Giovannini, Philippe A. Eigenmann, Jean-Christoph Caubet, and Antonella Muraro

Highlights

- Egg allergy is one of the most frequent food allergies in children.
- The use of egg white components can help distinguishing between allergy to baked, cooked and raw egg.
- The use of egg white components is clinically helpful for distinguishing between transient and persistent allergy to eggs.
- The result of an IgE test can confirm the diagnosis of egg allergy in the case of a clear clinical history of reaction; in equivocal cases, an oral food challenge to egg may be needed to clarify the diagnosis.

1 - The allergen sources

Hen's egg is a ubiquitous food eaten in most parts of the world. It is a cheap and easily accessible food source, used in many home-made dishes but also widely used by the food industry in processed foods. Allergenicity of baked egg (180°C for at least 20 minutes) might be reduced because interaction with the food matrix might block epitope access, and heating might destroy conformational epitopes. Individuals are mostly exposed to egg proteins in foods. Nevertheless, egg proteins can be found in aerosolized particles produced by cooking. Respiratory clinical manifestations to aerosolized egg proteins have been reported in bakery workers.⁹⁸³ Exposure to egg proteins via the respiratory route might also contribute to primary sensitization to eggs, similar to what has been

shown for peanut proteins⁹⁸⁴ Moreover, an increased risk of peanut allergy has been reported in infants with atopic dermatitis after a low-dose exposure to peanut proteins through the skin. It appears likely that low-dose cutaneous exposure can end in allergic sensitization to egg.⁹⁸⁶

2 - Major and relevant minor allergenic molecules and their clinical relevance

Five proteins most commonly involved in allergic reactions to hen's egg have been identified and characterized (Gal d 1 to 5, see Figure 82 and Table 35). Despite being present in a lower quantity in egg white than ovalbumin, ovomucoid is probably the immunodominant egg allergen.^{988,989} Among the various physicochemical characteristics, resistance to chemical denaturation has a direct clinical significance. Structural modification of egg allergens might allow safe consumption of cooked/baked egg-containing foods.

Clinical cross-reactivity occurs between various bird egg proteins (e.g., hen, turkey, duck and seagull).⁹⁸⁷ Thus, avoidance of other bird's eggs should be recommended when providing dietary guidance to egg-allergic patients.

3 - Clinical relevance, diagnosis and management

According to the IgE sensitivity of a given patient, three different clinical scenarios should be distinguished in a patient with a positive skin prick test or detectable levels of IgE to egg proteins^{990,991}:

1. Sensitized to eggs but clinically tolerant

Can eat all forms of eggs. Such patients will generally present a positive serum IgE test to egg white, in a low to mid-range value,

Major egg allergens:

ovomucoid

egg lysozyme

ovoalbumin

α -livetin

ovotransferrin

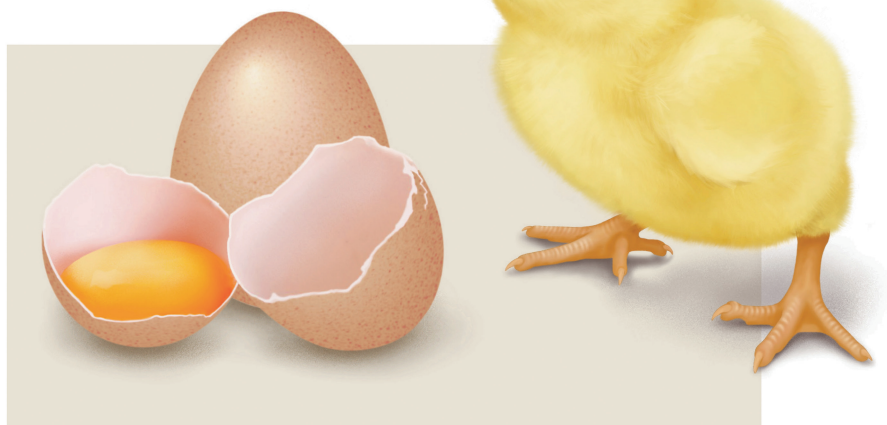


FIGURE 82 Major egg allergens

TABLE 35 Allergenic molecules of hen's egg and clinical relevance of specific proteins Adapted from [989]

Protein name	MW (kDa)	Protein family	Biological function(s)	Resistance to heating and chemical denaturation	Clinical relevance
Egg White Proteins					
Ovomucoid (Gal d1)	28	Kazal-type serine protease inhibitor	serine protease inhibition activity antibacterial activity	high	Heat-stable and highly allergenic. Risk for reaction to all forms of egg. High levels of specific IgE might indicate sustained egg allergy.
Ovalbumin (Gal d 2)	45	serine protease inhibitor	storage protein?	low	Heat-labile. Most abundant egg white protein. Risk for clinical reaction to raw or slightly heated egg.
Ovotransferrin or conalbumin (Gal d 3)	76-77	transferrin	iron-binding capacity with antimicrobial activity	low	Heat-labile. Risk for clinical reaction to raw or slightly heated egg.
Egg lysozyme (Gal d 4)	14.3	glycoside hydrolase family 22	antibacterial activity	moderate	Risk for clinical reaction to raw or slightly heated egg.
Ovomucin	165	contains trypsin inhibitor-like domains	heavily glycosylated protein with potent antiviral activities	n.a.	
Egg Yolk Proteins					
Phosvitin	35	transferase?	Metal-chelating agent	n.a.	
α -livetin (Gal d 5)	65-70	serum albumin	bind ions, fatty acids, hormones in physiological conditions	n.a.	
Apovitellenins I	9.5	very low-density lipoprotein	potent lipoprotein lipase inhibitor	n.a.	
Apovitellenins VI (orapoprotein B)	170	unknown	lipid-binding activity	n.a.	

as well as a negative or low serum IgE test to ovomucoid. Serum specific IgE to ovalbumin might be elevated in a similar range to the test to egg white.

2. Allergic to raw or partially raw eggs only

Tolerant to baked eggs or cooked eggs. These patients will generally present similarly to scenario one, with a positive serum IgE test to egg white, in a low to mid-range value, as well as a negative or low serum IgE test to ovomucoid. Serum specific IgE to ovalbumin might be elevated in a similar range to the test to egg white.

3. Allergic to all forms of egg

These patients generally have serum specific IgE to egg white in the middle to upper range. They might also have elevated serum specific IgE to ovomucoid and to ovalbumin.

Clinical history

The case history is decisive. It needs to be assessed if the patient has a concomitant atopic disease (e.g., atopic eczema), which might predispose to a positive test to egg white. If the child has a history of an allergic reaction after eating eggs, the history needs to specify to which form of egg the child reacted (baked, cooked, or raw eggs).

Skin prick test (SPT)

Skin prick test can be done with commercial egg white extracts or with raw eggs. Both have good accuracy for showing IgE sensitization. Extracts of major egg allergens (ovomucoid, ovalbumin or others) are not commercially available and are not used in routine diagnostic testing. A systematic review on diagnosis of egg allergy in children using cut-offs established that heated egg allergy seems

very likely if SPTs with egg white extract are >5 mm in children <2 years and >11 mm in children ≥2 years. In children <2 years, raw egg allergy appears very likely when SPTs with egg white extract are ≥4 mm; in children ≥2 years, raw egg allergy appears very likely when SPTs with egg white extract are ≥10 mm.⁹⁹²

Specific IgE testing

IgE to the following allergens are commercially available for testing: egg, egg white, egg yolk, ovomucoid (Gal d 1), ovalbumin (Gal d 2), ovomucoid (Gal d 3), egg lysozyme (Gal d 4).

Testing for specific IgE to egg white is, in general, mostly recommended for primary diagnosis of egg allergy in children. Egg white extract combines the most common major allergens recognized by egg allergic patient (ovomucoid and ovalbumin) and therefore constitutes the most accurate test for the initial diagnostic step.⁹⁹³ Moreover, levels of specific IgE to egg white might indicate the severity of egg allergy.⁹⁹⁴ In addition, egg white specific IgE levels have been studied in order to determine cut-off values indicative of true clinical egg allergy. However, diagnostic cut-offs vary with the characteristics of the patient populations, for instance age and presence or absence of eczema, and thus should be applied to populations with similar characteristics.⁹⁹⁵⁻⁹⁹⁸ A systematic review on diagnosis of egg allergy in children using cut-offs established that in children <2 years, raw egg allergy seems very likely when specific IgEs are ≥1.7 kU/l and in children ≥2 years raw egg allergy seems very likely when specific IgEs are ≥7.3 kU/l.⁹⁹²

Molecular diagnosis can be helpful to distinguish patients who are reactive to raw or partially raw eggs only from patients who are allergic to all forms of egg. Previous studies have defined a positive decision point for at least 95% clinical specificity for ovomucoid-specific IgE to diagnose allergy to cooked/ baked eggs.^{999,1000} Differences between studies done with different patient populations can limit the application of cut-off values to other populations.^{992,1001} However, high levels of specific IgE to ovomucoid can support the diagnosis of cooked/baked eggs allergy and persistent egg allergy as well.^{1002,1003} (Table 35).

The heat-labile egg white allergen ovalbumin can contribute to distinguish between the various pattern of clinical reactivity to eggs. Sequential testing starting with IgE measurement to egg white, followed by measuring IgE to ovalbumin and ovomucoid, can significantly improve the diagnosis of raw and cooked/baked egg allergy.^{999,1000} (Table 35).

It has been postulated that egg extracts modified by denaturation for mimicking the heating of eggs or egg digestion in the gut might provide more accurate proteins for clinical diagnosis. For distinguishing between egg sensitized subjects and patients allergic to all forms of eggs, native egg proteins provide reliable extracts for diagnosis as determined by receiver operating characteristic curves. For more refined diagnosis, denatured egg allergens might be helpful.¹⁰⁰⁰ Nevertheless, the clinical utility of such tests needs to be confirmed in larger patient populations.

Oral food challenge

The oral food challenge can be performed as open, single blind or double-blind, placebo-controlled challenge. Patients with

subjective symptoms should preferably be challenged in a double-blind, placebo-controlled challenge. Food challenges are helpful to get a definite diagnosis, in cases with a discrepancy between the clinical history and specific IgE results, as well as for the follow-up of food allergy. Depending on the clinical question, eggs might be given as raw, cooked, or in baked forms. Routine testing does not include challenges with isolated egg proteins. A study regarding the natural history of egg allergy reported that it resolved in 49.3% of egg-allergic children at a median age of 72 months.¹⁰⁰⁴ Thus, due to the natural history of egg allergy, which is frequently outgrown by 5-7 years of age, natural tolerance acquisition should be tested at regular intervals in average 6-12 months in the absence of an accidental reaction.⁷³ Moreover, introduction of baked egg might accelerate tolerance acquisition to all forms of eggs, but this requires further research.^{392,1005}

Clinical Management

Avoidance diet should be restricted to the form of egg not tolerated by the patient. All other forms should be regularly consumed. The diagnostic work-up, including history, SPT, specific IgE and oral food challenge as appropriate should aim to correctly identify forms of eggs to which the patient is tolerant. In addition to allergen avoidance, patients should be provided with medication, such as antihistamines, adrenaline auto-injectors and salbutamol, for treatment of acute allergic reactions due to accidental ingestions.

Allergen-specific immunotherapy

Various studies have shown clinical efficacy for specific oral tolerance induction protocols.³⁷⁷ Nevertheless, this procedure is not yet applicable to all patients.

5 - Clinical cases

Case 1

History: Girl, 8 months old, severe atopic eczema. Allergy testing is performed for ruling out food allergy as a triggering factor of her severe atopic eczema. She has never eaten eggs, neither isolated nor in processed foods.

SPT: 10 mm to egg white, negative to milk, wheat, soy, fish, peanut and hazelnut.

In-vitro testing: Total IgE 1825 kU/L, specific IgE to egg white 5.02 kU/L, ovalbumin 1.64 kU/L, ovomucoid 0.82 kU/L.

Oral challenge: Negative with baked products, well-tolerated, without immediate reactions or flaring of atopic eczema. The egg is progressively introduced at home in baked forms and in pasta with eggs.

Diagnosis: Sensitization to egg white in the context of severe atopic eczema.

Recommendation: Continue eggs in baked forms, retesting and perform a food challenge before introducing egg in cooked or raw forms.

Case 2

History: Girl, 13 months old, in good health. She has eaten cooked eggs, either isolated or processed foods, without any clinical

manifestations from 8 months of age. The girl is given for the first time a chocolate mousse made with raw beaten egg white. She presents within minutes a facial rash spreading to the upper thorax, a dry cough, and several episodes of sneezing. The signs and symptoms rapidly disappear after the administration of an oral antihistamine.

SPT: 5 mm to egg white.

In-vitro testing: Specific IgE to egg white 3.65 kU/L, ovoalbumin 1.56 kU/L, ovomucoid 0.78 kU/L. A low ovomucoid allergen-specific IgE (relatively to the specific IgE to egg white) is indicative of probable tolerance to cooked egg, which the girl tolerated.

Diagnosis: Allergy to raw eggs only.

Recommendation: Eggs well-tolerated in baked foods or cooked can be eaten. Elimination diet of incompletely cooked or raw eggs in any form. Follow-up at 25 months of age with measurement of SPT and allergen-specific IgE to egg white, ovoalbumin and ovomucoid, assess clinical reactivity with oral food challenge if there is a reasonable chance of tolerance acquisition.

Case 3

History: Boy, 9 months old, history of moderate atopic eczema. He eats for the first time a hard-boiled egg. Present within minutes an urticarial rash over the thorax, followed by an episode of vomiting. The clinical manifestations rapidly disappear after the administration of an oral antihistamine.

SPT: 9 mm to egg white.

In-vitro testing: Specific IgE to egg white 18.23 kUA/L, ovoalbumin 17.12 kUA/L, ovomucoid 8.56 kU/L. Diagnosis: Allergy to all forms of eggs.

Recommendation: Eggs in all forms and foods containing eggs need to be avoided. Follow-up at 21 months of age with measurement of SPT and allergen-specific IgE to egg white, ovoalbumin and ovomucoid, assess clinical reactivity with oral food challenge at first to the baked eggs if there is a reasonable chance of tolerance acquisition. Not thoroughly cooked eggs and raw eggs will probably need to be continued to be avoided.

6 – Conclusion

At the present stage, the measurement of serum IgE or skin prick testing to egg white should represent the first diagnostic test when assessing a patient with suspected egg allergy. Using tests with egg white components is most helpful for fine-tuning the diagnosis to predict tolerance to baked, cooked and raw eggs and for the follow-up of egg allergy. A definite diagnosis should always be made in relation to the clinical history, and if necessary, by a standardized food challenge. For general recommendations about food allergy diagnosis, the reader might also refer to the European Academy of Allergy and Clinical Immunology Food Allergy Guidelines.

B12 – Allergy to fish and *Anisakis simplex*

Leticia de las Vecillas, Lars K. Poulsen, Martine Morisset, Annette Kuehn

Highlights

- Fish species may differ by their allergenic potency.
- Proteins present in fish muscle, roe, skin or blood can elicit fish allergy.
- Less than 1% of the general population suffer from a fish allergy.
- Allergens from fish versus from shellfish and the fish parasite *Anisakis simplex* are not the same.
- Parvalbumin is the major fish allergen, but IgE spreading to other allergens is also common.
- *Anisakis simplex* allergy is diagnosed best using a combination of extract and single molecules while excluding sensitization to other parasites.

1 – The allergen source

FISH—Fish together with egg, milk and crustaceans represent the animal kingdom in the “big eight” group of food allergens, to which the majority of food allergic patients react. As fish is both an important food component and a potent source of food allergen, fish has also become a part of the European Union regulation of food labelling (EU regulation No 1169/2011), as allergy hazard of fish-containing commercial food products.¹⁹⁵ Despite the broad biodiversity among fish (more than 30,000 individual species have been described),

commonly consumed species are members of the Osteichthyes group (bony fish) and belong to a limited number of orders, the salmon-like (Salmoniformes), cod-like (Gadiformes), perch-like (Perciformes), herring-like (Clupeiformes), carp-like (Cypriniformes), catfish-like (Siluriformes), and platfish (Pleuronectiformes) (Figure 83).

Globally, a high number of fish species is commercially available. The market share of these species varies in different countries according to regional production sites and eating habits. While cod and salmon are important food fish in Europe, other low-value freshwater species are popular in Asia (e.g., grass carp and Asian carp). Fish allergens have been described in about 40 species, but detailed analysis of the allergy-eliciting molecules was performed mainly for fish, which are commonly consumed in the European area such as carp, cod, salmon, trout and tuna.¹⁹⁵ Meanwhile the knowledge on food allergy to other species such as barramundi and catfish is growing.^{1009,1010} A large and clinically relevant cross-reactivity seems to exist between parvalbumins of different fish species (see chapter C11). The following fish products can be elicitors of mild to severe allergic reactions in sensitized patients.

Fish meat—The largest allergenic activity resides in the muscle of the fish.¹⁹⁵ Fish is consumed as cooked, fried, pickled or even raw food product. Food processing seems not to affect the allergenic potency of the fish but rather the allergen content, which varies in different species.¹⁰⁰⁹ Parvalbumins, the major fish allergens, are highly abundant in the fish muscle. With a serving size of 200 g cod filet, the consumer might ingest up to 0.5 g of parvalbumin per meal. Other fish allergens present in the muscle are enolases, aldolases, collagen, tropomyosin and others. As a food ingredient, fish must be listed specifically on a product label regardless of the percentage of content.

Eggs, roe, caviar—There are case reports that caviar has elicited allergic reactions. Typically, roe is consumed in its raw form. Fish

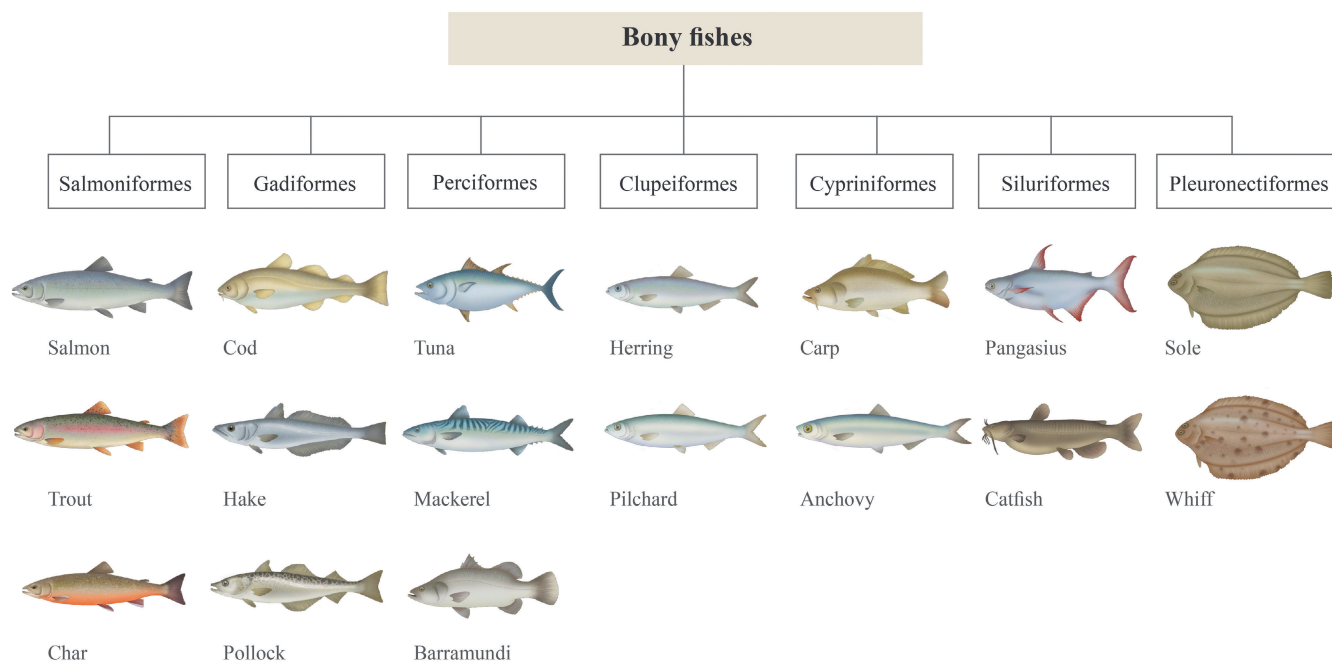


FIGURE 83 Most important food fish are members of seven taxonomic orders.

muscle allergens are not relevant in this context. Vitellogenin has been identified as an important fish egg allergen.¹⁹⁵ This protein and its metabolites represent nearly the total protein content in roe. The knowledge about fish egg allergens improved over the past year, including the production of the first recombinant molecules.¹⁰¹¹

Fish gelatin, isinglass, and similar products—Concern has been raised as to whether fish-derived products such as fish gelatin may have allergenic properties. Fish gelatin, hydrolysed collagen, is made from fish skin and bones. Isinglass is derived from fish swim bladder and largely contains collagen. Food (beverages, candy), pharmaceutical (gel capsules and coatings) or biological (vaccines, sublingual immunotherapy) products may contain these ingredients. Allergenicity appears to be inherent to collagen-like products¹⁰¹² but might also stem from contaminations by fish meat residues. Consumers are not aware of these fish-derived food ingredients as they are exempted from the food labelling regulation.

Fish blood—Fish hemin (fish blood) or other blood proteins have been used by the food industry as additives or processing aids, but it seems to be a relevant source of allergens only in the fish-processing environment. Occupational asthma might be linked to the aerosolization of potentially blood-derived allergens during processing of fish. Serum albumin has been suggested as a potential allergen, but this and other allergens could be not confirmed so far.^{1013,1014}

The term seafood comprises both fish and shellfish (e.g., shrimps, crabs, lobster, mussels, oysters, octopus, squid¹⁰¹⁵). Considering the large phylogenetic distance between fish and these other organisms it is not surprising that little cross-reactivity occurs. Therefore, seafood other than fish as allergenic food will not be discussed further in the context of fish allergy (see chapter B13). Nevertheless, a case of cross-allergy between fish and shrimp tropomyosins has recently been reported.¹⁰¹⁶

ANISAKIS SIMPLEX—*Anisakis simplex* is a parasite of the Nematoda phylum, which is able to induce IgE sensitization.¹⁰¹⁷ It is increasingly recognized as a relevant allergenic component mostly in fish.¹⁰¹⁸ It is important to keep *Anisakis simplex* allergy in consideration when diagnosing patients experiencing allergic reactions after eating fish mainly when specific fish such as European hake, Atlantic horse mackerel, blue whiting or anchovies are involved. Debenedetti et al (2019); see comment in reference list¹⁰¹⁶ Humans become an incidental host after eating raw or undercooked fish containing live larvae. Freezing fish at -20°C for at least 24 h will kill the larvae, however. When parasitized fish is consumed, larvae can penetrate the gastrointestinal mucosa and induce abdominal pain, digestive symptoms and sometimes fever (anisakiasis). Upon reexposure, sensitized individuals may also develop allergic signs. Reactions can include typical allergic and/or gastrointestinal symptoms (gastroallergic anisakiasis). It is assumed that sensitization can also occur to dead larvae material i.e., without first developing anisakiasis. In this case freezing will not ascertain full safety, albeit the parasites are killed. It is important to keep *Anisakis simplex* in consideration when diagnosing patients experiencing allergic reactions following fish ingestion. When testing for IgE against parasites it should be remembered that there is a considerable cross-reactivity between different nematode species e.g., *Anisakis* and *Ascaris*.^{1020,1021}

2 – Fish allergens (parvalbumin and others) and *Anisakis* allergens.

FISH—A search in the WHO/IUIS database currently reveals 40 entries while the database Allergen Online (www.allergenonline.org, version 21) comprises 83 fish allergens of known sequence. Sixteen and 40, respectively, of these belong to the parvalbumin family (Table 36). Further allergens are enolases (n=5), aldolases (n=4), tropomyosin (n=3), vitellogenin from salmon roe (n=1) and others (n=11). These are discussed further below.

Fish as an allergenic source

- Fish species may differ by their allergenic potency.
- Allergy might be elicited by proteins present in fish muscle, skin or blood.
- Allergens from fish and shellfish (e.g., crustaceans, molluscs) are not the same.
- *Anisakis simplex*, a parasite residing in fish muscle, can be another source of IgE-mediated hypersensitivity after fish ingestion.

Fish meat—The dominating major allergen in fish muscle is parvalbumin of which the codfish molecule Gad c 1 was the first to be identified (see chapter C11).¹⁹⁵ Subsequently, studies were performed with a number of homologous proteins such as Gad m 1 from Atlantic cod, Cyp c 1 from Common carp and Sal s 1 from Atlantic salmon (Figure 84; left panel). Parvalbumins are small muscle proteins (10–12 kDa) of remarkable stability towards physicochemical effects by food processing. During fish preparation and cooking, these allergens may become aerosolized and inhaled causing respiratory symptoms.^{1014,1022,1023} Because of specific characteristics of their protein structure, these calcium-binding allergens belong to the so-called EF-hand family (Figure 85).¹⁰²⁴ The parvalbumin levels vary considerably in different fish tissues and species.¹⁰⁰⁹ Carp and herring muscle contain about 100-times more parvalbumin than mackerel and tuna. Most fish-allergic patients have specific IgE to these allergens (Table 36). Highly conserved parvalbumin epitopes have been used to explain not only IgE but also clinical cross-reactivity among various fish species. Parvalbumins cluster into two molecular subtypes, parvalbumins from the alpha- and the beta-lineage. Common fish allergens, as listed in Table 36, are beta-parvalbumins. Alpha-parvalbumins, such as parvalbumins found in ray and shark, appear to have minor cross-reactivity with beta-homologues (see chapter C11). Beyond parvalbumin, other fish allergens were identified, namely 50 kDa-enolases and 40 kDa-aldolases from cod, salmon, tuna and more recently Cyp c 2 from carp and Pan h 2 and Pan h 3 from catfish.^{1010,1022} These glycolytic enzymes are highly expressed in the fish muscle. Their potency as food allergens still needs to be defined as they are less stable than parvalbumins. However, a number of fish-allergic subjects seem to

TABLE 36 Major and relevant minor fish allergenic molecules

Order	English name (species)	Allergenic molecule ^A	Biochemical name	Prevalence [%] ^B	MW [kDa]
Clupeiformes	Herring (<i>Clupea harengus</i>)	Clu h 1	parvalbumin	45	12
	Pilchard (<i>Sardinops sagax</i>)	Sar sa 1	parvalbumin	80	12
Cypriniformes	Carp (<i>Cyprinus carpio</i>)	Cyp c 1	parvalbumin	100	12
		Cyp c 2	enolase	17	47
	Grass carp (<i>Ctenopharyngodon idella</i>)	Cten i 1	parvalbumin	94	9
Gadiformes	Atlantic cod (<i>Gadus callarias</i>)	Gad c 1	parvalbumin	100	12
		Gad m 1	parvalbumin	100	12
	Atlantic cod (<i>Gadus morhua</i>)	Gad m 2	enolase	56	50
		Gad m 3	aldolase	37	40
Perciformes	Tuna (<i>Thunnus albacares</i>)	Thu a 1	parvalbumin	95	11
		Thu a 2	enolase	19	50
		Thu a 3	aldolase	13	40
	Barramundi (<i>Lates calcarifer</i>)	Lat c 1	parvalbumin	77-83	11.5
		Lat c 6	collagen	22	130, 140
	Mozambique tilapia (<i>Oreochromis mossambicus</i>)	Ore m 4	tropomyosin	100	33
	Indian mackerel (<i>Rastrelliger kanagurta</i>)	Ras k 1	parvalbumin	83	11.3
	Atlantic mackerel (<i>Scomber scombrus</i>)	Sco s 1	parvalbumin	95	12
	Swordfish (<i>Xiphias gladius</i>)	Xip g 1	parvalbumin	71	11.5
Pleuronectiformes	Megrim (<i>Lepidorhombus whiffiagonis</i>)	Lep w 1	parvalbumin	100	11.5
Salmoniformes	Pacific salmon (<i>Oncorhynchus keta</i>)	Onc k 5	vitellogenin	nd	18
		Rainbow trout (<i>Oncorhynchus mykiss</i>)	Onc m 1	parvalbumin	95
	Salmon (<i>Salmo salar</i>)	Sal s 1	parvalbumin	49-64	12
		Sal s 2	enolase	24-34	50
		Sal s 3	aldolase	16-26	40
		Sal s 4	tropomyosin	13	37
		Sal s 6	collagen	22	130, 140
		Sal s 7	creatine kinase	14	43
		Sal s 8	triose-P isomerase	34	25
Sal s 9	nd	nd	nd		
Scorpaeniformes	Redfish (<i>Sebastes marinus</i>)	Seb m 1	parvalbumin	95	11
Siluriformes	Striped catfish (<i>Pangasianodon hypophthalmus</i>)	Pan h 1	parvalbumin	42	11
		Pan h 2	enolase	21	50
		Pan h 3	aldolase	21	40
		Pan h 4	tropomyosin	6-32	35
		Pan h 7	creatine kinase	10	43
		Pan h 8	triose-P isomerase	19	21
		Pan h 9	pyruvate kinase	6	65
		Pan h 10	lactate DH	13	34
		Pan h 11	glucose-6-P DH	8	60
		Pan h 13	glyceraldehyde-3-P DH	6	36

^AAllergens recognized by the WHO/IUIS allergen nomenclature subcommittee (for parvalbumins from other species, see chapter 'Parvalbumins').

^BPrevalences are extracted from www.allergen.org/literature reference cited there. DH, dehydrogenase; P, phosphate. nd, not determined.

have IgE against these allergens (Table 36). *In-vitro* cross-reactivity occurs for homologues from cod, salmon and tuna. Other fish muscle allergens are relevant, e.g., tropomyosin, creatine kinase and triosephosphate isomerase described in salmon and catfish as well as pyruvate kinase, lactate dehydrogenase, glucose-6-phosphate

dehydrogenase, and glyceraldehyde-3-dehydrogenase discovered in catfish.¹⁰¹⁰ It can be expected that further studies will confirm the clinical value of including those allergens into a diagnostic panel.

Fish gelatin and collagen—Collagen consists of three individual polypeptide chains corresponding to two alpha-subunits (a1, a2;

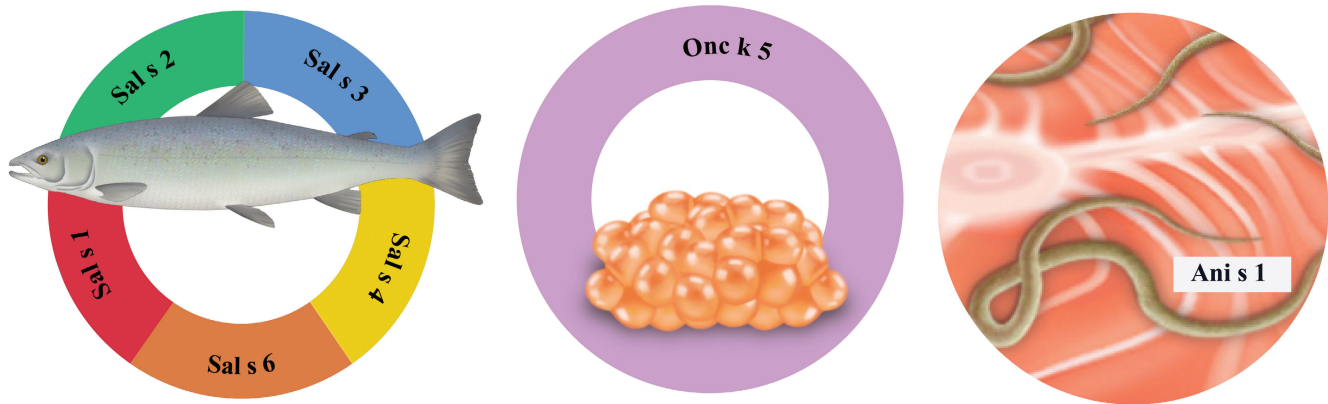


FIGURE 84 Most important allergens from Atlantic salmon muscle, roe, and contamination with *Anisakis simplex*

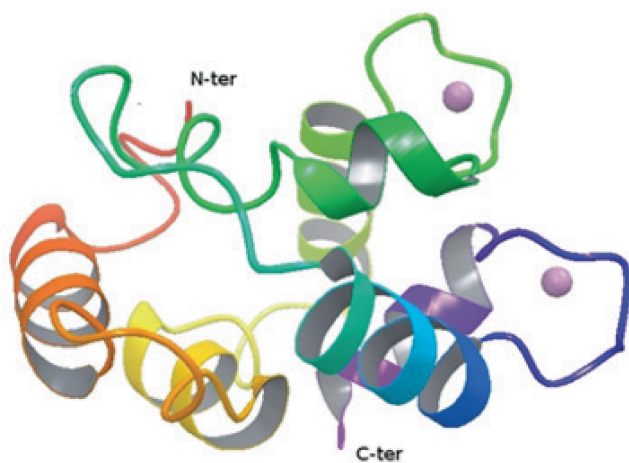


FIGURE 85 Protein structure of parvalbumin Cyp c 1 from carp (pdb 4CPV). Two EF-hand motifs bind each a Ca^{2+} -molecule.

each 110 kDa) and one beta-subunit (210 kDa). These chains forming a tight right-handed twist causing them to form a rod shape triple helix. Fish gelatin is a heterogeneous product being obtained from acidic acid extraction of collagen followed by chemical hydrolysis. According to the molecular weight of fish gelatin components, it is available at different hydrolysate grades. Anaphylaxis to fish gelatin has been documented in case reports.^{1025,1026} Fish gelatin differs considerably by its amino acid composition from mammalian homologues. It is therefore coherent that there is no cross-reactivity among these products. More recently, the allergenic potency of fish collagen was confirmed in several fish species, salmon, barramundi and catfish, corroborating earlier reports.^{1012,1025} It is important to be aware that fish gelatin and collagen may be used as additives or processing aids in drugs, vaccines and food products normally thought to contain fish proteins, and may therefore be more prone to act as a hidden allergen.

Roe—The allergens of roe, also referred as caviar or fish eggs, are different from those of fish meat and fish skin. Patients with roe allergy often tolerate fish meat and vice versa. Vitellogenins are glycolipoproteins of high molecular weight (>150 kDa) belonging to the

family of lipid transport proteins. Studies of allergens from salmonid roe have led to the identification of a 35-kDa vitellogenin fragment consisting of two partly identical subunits (18 and 16 kDa) named *Onc k 5* (Figure 84).¹⁹⁵ Cross-reactivity has been proven for roe allergens from different fish species by IgE and skin testing. However, no cross-reactivity was found to homologues from chicken yolk.

ANISAKIS SIMPLEX—Fourteen allergens are available via official allergen names (Table 37), allergen online contains 33 entries in total.¹⁰²⁷ These cluster according to their origin from the parasite into allergens from dead/ disintegrated (somatic, SO; cuticular, C) and from living larvae (excretory/secretory, ES)¹⁰²⁸. There is a notion that ES allergens are more potent than SO/C allergens.¹⁰¹⁷ Further allergens are known from *Anisakis pegreffii*; however, focus will be given here to the officially approved allergens.

SO allergens—They are present in the body of the parasite. Specific IgE reactivity to those allergens relates to sensitization but not necessarily clinical allergy.

Ani s 2 (paramyosin) and *Ani s 3* (tropomyosin) bear high homology and strong cross-reactivity to house dust mite and crustacean homologues.^{1017,1028} The biological function of *Ani s 10*, another SO allergen, remains to be clarified.

C allergens—They are released during a specific window of the larval life cycle in transition from L3 to L4 stage. It seems that these antigens are involved in a chronic stimulus inducing granulomas and other chronic lesions. *Ani s 4*, an antigen that belongs to the cysteine protease inhibitors family, it has been shown to be presented not only in the excretory gland but also in the cuticle of the parasite.

ES allergens—These antigens are histolytic enzymes secreted through the dorsal oesophageal gland and the excretory cells on the digestive tract of L3-stage larvae. Their function is to facilitate the parasite's infiltration through the digestive mucosa of its host. *Ani s 1*, *Ani s 4*, *Ani s 5*, *Ani s 6*, *Ani s 7*, *Ani s 8*, *Ani s 9* and *Ani s 13* can induce both sensitization and elicitation of allergic symptoms.^{1029–1031} Three of these are considered major allergens, *Ani s 1*, an inhibitor of Kunitz-type serine proteases, *Ani s 7*, a protein of unknown biological function and *Ani s 13*, a protein of haemoglobin function. Structural homologues to *Ani s 7* and *Ani s 13* in other allergen sources are unknown so far.

TABLE 37 Major and relevant minor *Anisakis* simplex allergenic molecules

Allergenic molecule ^a	Biochemical name	Prevalence [%] ^a	MW [kDa]
Ani s 1	Kunitz serine protease inhibitors	85	24
Ani s 2	Paramyosin	88	97
Ani s 3	Tropomyosin	nd	41
Ani s 4	Cysteine protease inhibitor	27	9
Ani s 5	SXP/RAL-2 family protein	25	15
Ani s 6	Serine protease inhibitor	18	7
Ani s 7	Glycoprotein	83–100	139
Ani s 8	SXP/RAL-2 family protein	25	15
Ani s 9	SXP/RAL-2 family protein	nd	14
Ani s 10	nd	39	21
Ani s 11	nd	47	27
Ani s 12	nd	57	31
Ani s 13	Haemoglobin	64	37
Ani s 14	nd	54	24

^aAllergens recognized by the WHO/IUIS allergen nomenclature subcommittee.

^bPrevalences are extracted from www.allergen.org/literature reference cited there. nd, not determined.

3 – Sensitization to individual molecules and its clinical relevance

FISH—So far, epidemiological studies on fish allergy are missing to present consistent data of sensitization to fish and fish allergens. Prevalence rates specifically to fish have been determined in studies of variable design and methodology.^{1032–1034} Overall, it seems that <1% of the global population are affected by allergy to fish. A higher percentage is observed in paediatric cohorts and in countries with long coastlines, which have a high fish consumption, as well as in regions with fish-processing industries (up to 3%). Patients get sensitized to fish not only upon ingestion but also skin contact and inhalation of fish steam during processing of this food.^{195,1018} Occupational asthma has been reported in 7–36% of workers in industrial fish production lines.¹⁰²³

Clinical relevance of fish allergens

- Less than 1% of the general population suffer from a fish allergy.
- Parvalbumin is the major fish allergen (prevalence rates 70–95%).
- Most patients have often sIgE to multiple fish allergens, including enolases, aldolases, collagen and tropomyosin.

Parvalbumins have been defined as pan-allergens in fish.¹⁹⁵ In this chapter, we will focus on parvalbumins from the beta-lineage, which are known as important fish allergens. More details on alpha-parvalbumins, including their low cross-reactivity with beta-homologues can be

found in the chapter C11. Sensitization rates for beta-parvalbumins were based on studies of allergen characterization. First it was concluded that 90–95% of the patients had specific IgE to these muscle proteins. Studies of the past decade showed that the fish-allergic population can be subdivided into the following clinical clusters, i. highly sensitized patients reacting to all fish, ii. oligo-sensitized patients reacting to several, specific fish and iii. patients with “selective reactions” to individual fish species only.^{195,1035} Patients of these clinical clusters vary by their IgE-recognition profiles. It was shown that the prevalence of IgE binding to parvalbumin was lower than assumed for long time. The sensitization rate to this major allergen might be rather range at about 70 to 95%, depending on the study cohort. Beyond parvalbumin, a polyclonal immune response to multiple fish allergens correlates with clinical reactivity, as demonstrated for cod, salmon and catfish allergy.^{1025,1036} A single study demonstrated that fish-allergic patients with specific IgE to cod parvalbumin might be co-sensitized to cod enolases (81%) and aldolases (58%).¹⁰¹⁰ The clinical origin and relevance of this co-sensitization is still not yet resolved. However, specific parvalbumin-negative patients seem to develop IgE antibodies to fish enolase (47%) and aldolase (41%), which is rather linked to species-specific fish allergies.¹⁰³⁷ It is important to note that there are still limited data available to delineate how many patients can be categorized in each proposed clinical cluster. Also, it has to be taken into consideration that a geographical and/or a temporal gradient might be relevant for such a prevalence data collection.

ANISAKIS SIMPLEX—The seroprevalence appears to vary between countries, such as a pronounced occurrence reported in Mediterranean countries.^{1031,1038} The vast majority of allergic cases to the parasite are after food intake; however, contact dermatitis and conjunctivitis as well as occupational bronchial asthma have been described as well.¹⁰¹⁷ In the literature, there is a lack

of consistency to differentiate between allergy and asymptomatic sensitization. In fact, traditional test such as skin prick test (SPT) and *Anisakis* simplex-specific IgE using the whole extracts have shown low specificity.¹⁰³⁸ Various studies approached the identification of clinically relevant allergens in order to discriminate genuine allergy from molecular cross-reactivity. IgE reactivity to ES-allergens showed to correlate with clinical reactivity. Due to the lack of homology with other allergens, Ani s 1 and Ani s 7 bear a good diagnostic capacity to identify true *Anisakis* simplex allergy.^{1039,1040} Ani s 1-specific IgE are found predominantly on patients presenting with severe allergic reaction. Though Ani s 7 is a frequently IgE-recognized molecule, it seems less clinically relevant, which can be explained by a parallel IgG4-response resulting into a protection against adverse symptoms.¹⁰⁴¹ The ES allergen Ani s 13 has been reported as another marker for primary sensitization and clinical allergy. Ani s 2 and Ani s 3 are *Anisakis* simplex pan-allergens but with high cross-reactivity to other allergen sources such as mites, insects, shellfish, cockroach, and chironomids, thus a less specific marker.^{1017,1018,1029}

Clinical relevance of *Anisakis* simplex allergens

- The seroprevalence ranges between 0.2 and 15% in the general population.
- Specific IgE to the whole extract is not always related to symptomatic allergy.
- Ani s 1 appears to be a clinically relevant allergen from *Anisakis* simplex.

4 – Clinical management

FISH—Fish allergy diagnosis is mostly based on clinical history, skin tests (prick tests to fish extract or prick-to-prick with the culprit fish -raw and cooked-) and IgE tests, followed (if needed) by an oral food challenge (ideally, double-blind placebo-controlled challenge) with the fish that has elicited the reaction.^{195,1031} Level of serum IgE antibodies have been correlated with the clinical reactivity to predict allergy to fish. In a US population, an IgE level of 20 kU/L to cod extract (ImmunoCAP Specific IgE test, Thermo Fisher) allowed to predict an allergy to this fish with 95% certainty.¹⁰⁴² More recently, a large food challenge-based study reported that combining an obvious clinical history of patients with sIgE to cod extract >8.2 kU/L or to salmon extract >5 kU/L should result in advising to avoid consuming all fish species.¹⁰³⁶ A specific cod IgE titer >5 kU/L has been even reported to be useful regarding an unfavorable prognosis to outgrow fish allergy.¹⁰³⁵ The availability of individual allergens for IgE testing is still limited and thus, not of much help in predicting whether the patient is allergic to other fish species. However, an outline of the future diagnosis using single

allergens is presented in the “Clinical cases” and in the chapter C11. Meanwhile, a novel multiplex platform (MadX, MacroArray Diagnostics) made a number of parvalbumins from several fish species available, in addition to the other fish allergens cod enolase and aldolase (Gad m 2, Gad m 3).

Two important questions should be addressed if the initial suspicion of fish allergy is confirmed by the challenge procedure (Figure 86). Firstly, how sensitive is the patient? This can normally be deduced from the titrated challenge procedure, and the patient should be advised for future dietary precautions based on his or her individual threshold. Of note, the scheme in (Figure 87) reflects a complete workflow, rather than a temporal sequence. Skin test results might be earlier available than IgE serology. Food challenges are advised against in case of a suspected severe reaction. As reviewed under “Parvalbumins,” some fish-allergic patients can develop a cross-reactivity to chicken meat due to parvalbumin cross-reactivity.¹⁹⁵ Prick-to-prick testing with chicken meat (both, leg and breast meat) and serum IgE testing to chicken meat might be recommended in case of a positive clinical history. During the procedure of diagnosis as proposed in Figure 86, the assessment of a putative *Anisakis* simplex allergy shall be included, especially if results of fish allergy tests are unequivocal.¹⁰¹⁷ Skin prick tests and IgE serology can be useful to demonstrate sensitization. It is important to keep in mind that IgE testing with *Anisakis*-extracts can produce false-positive results due to molecular cross-reactivity, such as to shellfish or insect allergens.

The second question relates to the degree of cross-reactivity between fish species (Figure 87). If the patient reacts with IgE of similar magnitude and reacts to a parvalbumin it is likely that there is a broad cross-reactivity. If the sensitization pattern suggests a more “selective” reaction to specific fish, an open challenge may be performed to confirm this tolerance. For this, the choice of the fish can be adapted according to the clinical history of the patient. Especially fish with a low parvalbumin content, such as tuna, as well as fish distantly related to cod, such as ray, a cartilaginous fish with low cross-reactive alpha-parvalbumins, might be of importance to test for oral tolerance and alternative introduction into the diet (see chapter C11).²⁰⁸ If the patient presents primarily with digestive symptoms without cutaneous signs, non-IgE-mediated food allergy might be suspected (food protein enterocolitis syndrome/FPIES in children, eosinophilic oesophagitis (EoE) in children and adults.¹⁰⁴³ Also, histamine fish poisoning leads to the induction of allergy-like symptoms.

History of exposure—As for diagnosis of fish-allergic patients, it should be remembered that most people are aware of ingesting fish, and thus the patient history is often quite reliable as for the exposure (which does of course not exclude other ingredients in a meal). While probably extremely rare, there are examples of patients reacting to fish allergens that are hidden in foods.¹⁹⁵ It is obviously difficult to demonstrate a 100% safety level, but several studies have suggested that some fish-derived food additives seem to have a quite low risk of causing reactions in previously sensitized fish allergic persons.

Case history: Immediate reaction after potential consumption of fish (product)

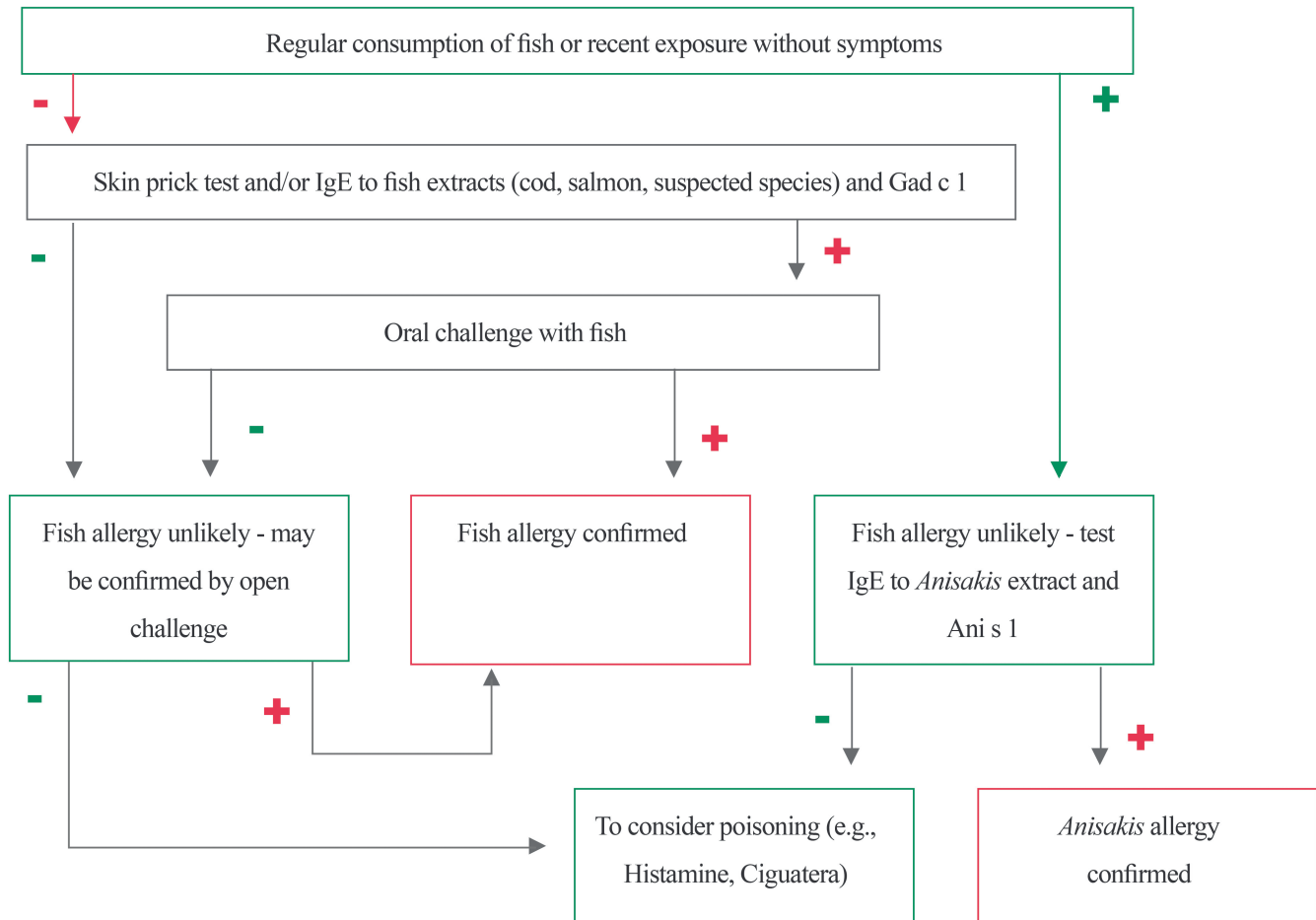


FIGURE 86 Diagnostic algorithm in patients with suspected fish allergy

Quantitative risk assessment—As relating to the dose of fish producing food-allergic symptoms only data for fish meat are available in the published literature. According to the literature, the lowest provoking dose is in the low milligram range. A larger population was tested in the EuroPrevall project, an EU-funded project the prevalence, costs, and basis of food allergy across Europe, and an ED10 of 27.3 mg of cod protein was found, which was confirmed later.^{554,988,1036}

Other risk factors—It is important to notice that parvalbumins, the major fish allergens, are highly heat-stable.^{195,208} Thus, their allergenicity cannot be expected to be reduced upon food processing. However, its proteolytic resistance seems to be lower, for example, to pepsin at low pH. Accordingly, maintenance of a well-functioning digestive system with low ventricular pH may be of importance for avoiding fish allergy.

ANISAKIS SIMPLEX—The diagnosis of anisakiasis is mainly based on the clinical presentation and the observation of larvae during an endoscopy.

Differential diagnosis—How the differential diagnosis is proceeded along with a genuine fish allergy diagnosis, is represented in (Figure 86). When specific IgE to *Anisakis* extract is positive in a patient with ambiguous clinical history, sensitization to invertebrates (e.g., house dust mites, crustaceans and nematodes) should be considered.^{1017,1028,1038} Previous studies have also shown that the *Anisakis* simplex allergy evaluation should also include IgE testing to *Ascaris*, another potentially cross-reacting nematode. When doing this, it has been shown that diagnostic specificity increases: by forming the ratio between both (*Anisakis*/*Ascaris*-IgE ≥ 4.4 , specificity $>95\%$).¹⁰³⁸ Further studies will be needed to elaborate on reliable diagnostic cut-off points.^{1039,1044}

Risk factors—In addition to fish consumption habits, such as raw fish intake and intake of species that are known to be more often contaminated with parasites (e.g., hake, mackerel, anchovies), certain professions related to fish handling appear to be also a risk factor for sensitization.¹⁰⁴⁴

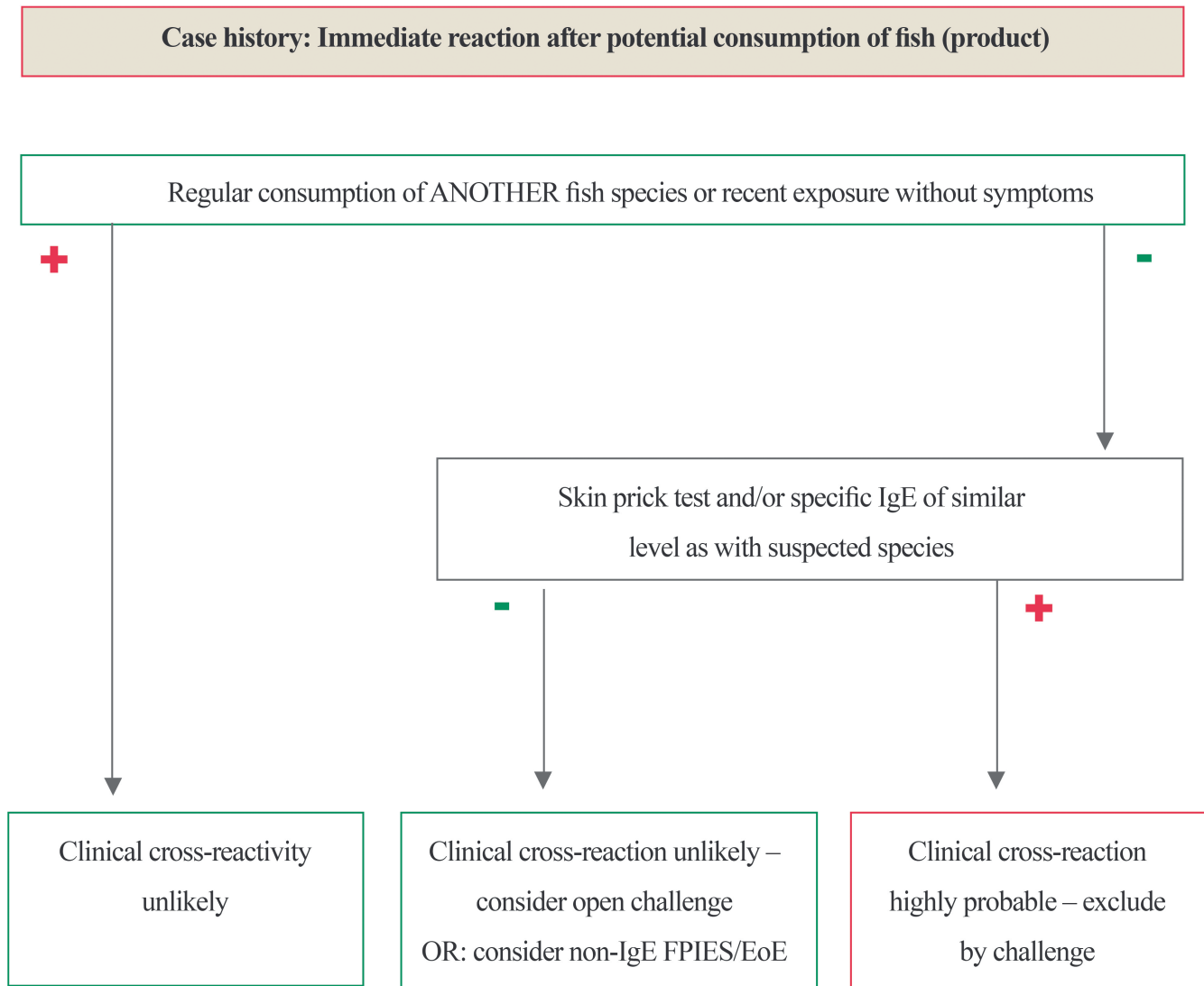


FIGURE 87 Diagnostic algorithm in patients with suspected allergy to single or specific fish

5 – Clinical cases

Most cases of fish allergy present with classical food allergic symptoms short after intake of fish. Symptoms may include oral allergy syndrome, rhinitis/conjunctivitis, asthma, urticaria, and gastrointestinal symptoms. There is an increasing number of reports on non-IgE-mediated fish allergy (FPIES and EoE), involving mostly symptoms of the digestive tract.¹⁰⁴³ For the clinical cases, we will focus on IgE-mediated fish allergy to demonstrate the value of molecular diagnosis. However, FPIES and EoE should be always considered in alignment with clinical symptoms and negative IgE tests. Like genuine fish allergy, clinical manifestations of *Anisakis simplex* allergic occur also very quickly, leading to food allergy-typical symptoms.

Case 1 (published)¹⁰³⁶ (Figure 88)

Clinical History: A young patient, 11 years, had a clinical history of fish allergy with clinical symptom development on several occasions.

Test with extracts: Specific IgE were positive for cod extract (117 kU/L), salmon (144 kU/L) and mackerel (52.1 kU/L). Food challenge—The patient has a positive food challenges with cod, salmon and mackerel (cumulative eliciting doses 1 g, 1 g and 2 g, respectively).

Test with molecules: Specific IgE were found for cod, salmon and mackerel parvalbumins (121.7 kU/L, 30.3 kU/L and 49.2 kU/L, respectively) but also for enolases (61.5 kU/L, 9.5 kU/L and 1.1 kU/L, respectively) and aldolases (63.1 kU/L, 18.3 kU/L and 0.5 kU/L, respectively).

Conclusion: In this case, the clinical cross-reactivity to unspecific fish was confirmed by the detection of specific IgE to a broad panel of fish allergens, including parvalbumins, enolases and aldolases.

Case 2 (published)¹⁰¹² (Figure 89)

Clinical History: Female patient, 17 years old, presenting with oral allergy syndrome and rhinitis upon consumption of fish (species unknown, tuna suspected).

Test with extracts: Skin testing was negative with tuna and salmon. ImmunoCAP Specific IgE test for tuna extract was 3.2 kU/L.

Food challenge: The patient refused a food challenge. Test with molecules—IgE-ELISA was positive for purified collagen from tuna, barramundi, and salmon. IgE ELISA was negative for tuna parvalbumin. IgE reactivity was further confirmed by immunoblot analysis using purified tuna collagen and in basophil activation assay.

Conclusion: The patient demonstrated IgE reactivity to tuna collagen but absence of reactivity to tuna parvalbumin. Negative SPT to tuna extract may be explained by low amount of collagen in the fish extract used for SPT.

Case 3 (published)¹⁰⁴⁵ (Figure 90)

Clinical History: Male patient, 7 years old, presenting with urticaria and vomiting upon consumption of fish as well as vomiting upon consumption of chicken meat.

Test with extracts: Skin testing were positive with cod and chicken. ImmunoCAP Specific IgE test for cod extract was 5.4 kU/L and with chicken meat 8.9 kU/L.

Food challenge: The patient reacted in a food challenge upon ingestion of a dose of 100 mg chicken meat.

Test with molecules: IgE-ELISA was negative with purified parvalbumins and aldolases from cod and chicken. IgE ELISA was positive for both cod and chicken meat enolase (4.3 kU/L and 4.6 kU/L, respectively).

Conclusion: A clinical cross-reactivity was confirmed by positive IgE reactivity for cross-reactive allergens cod Gad m 2 and chicken Gal d 9.

Case 4 (original) (Figure 91)

Clinical History: A 45-year-old woman presented left hemi-abdominal pain, urticaria and dyspnea with desaturation, 30 minutes after eating raw anchovies.

Test with extracts: Skin testing was positive for *Anisakis simplex* extract. Specific IgE were positive for *Anisakis simplex* (14.3 kU/L) and borderline positive for anchovy (0.3 kU/L) and *Ascaris* (0.5 kU/L). The ratio for *Anisakis/Ascaris*-IgE was 28.6.

Food challenge: The patient refused a food challenge with anchovy.

Test with molecules: Specific IgE were positive for Ani s 1 and Ani s 7 in allergen-specific ELISA.

Conclusion: In this case, *Anisakis simplex* allergy was confirmed by the detection of IgE to specific allergen Ani s 1.

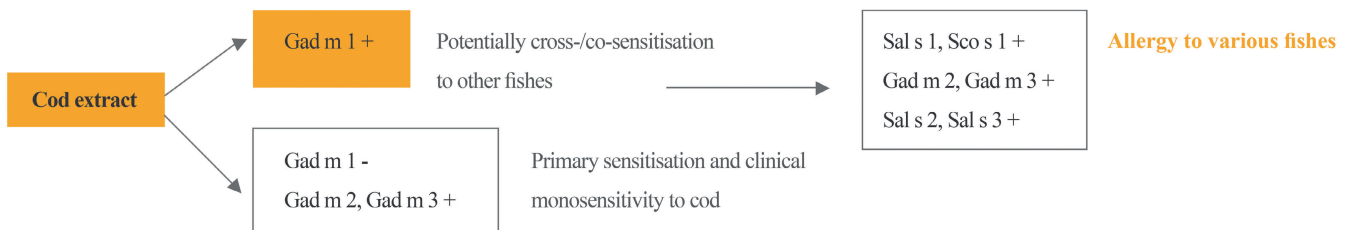


FIGURE 88 Diagnostic procedure Case 1. Orange text box = established diagnosis

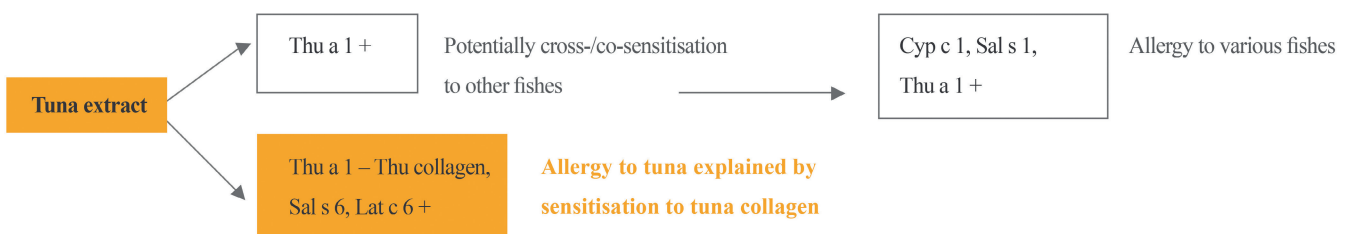


FIGURE 89 Diagnostic procedure Case 2. Orange text box = established diagnosis

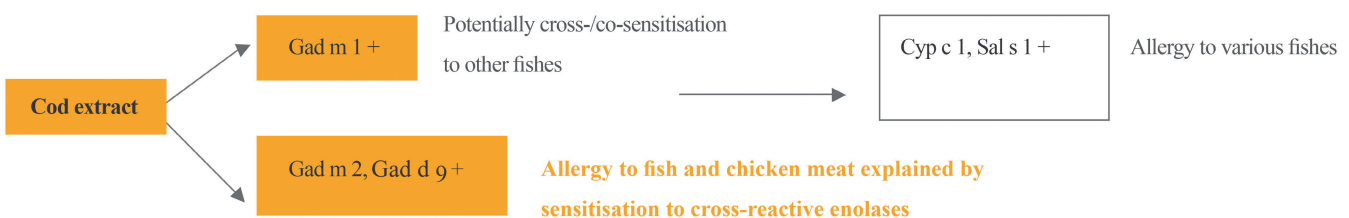


FIGURE 90 Diagnostic procedure Case 3. Orange text box = established diagnosis

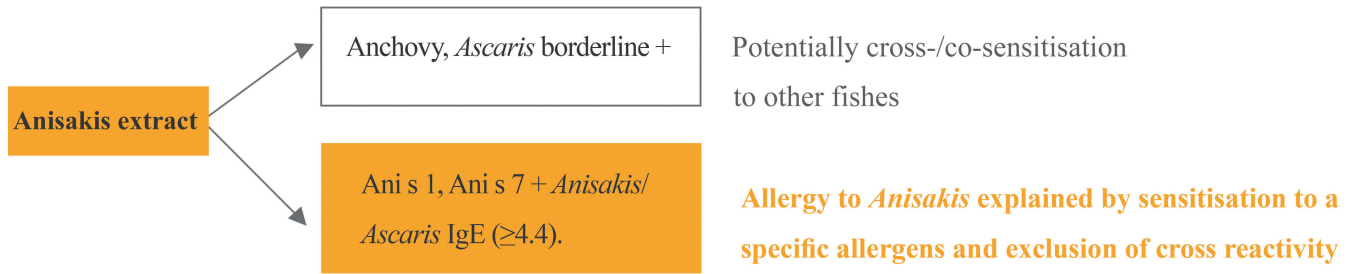


FIGURE 91 Diagnostic procedure Case 3. Orange text box = established diagnosis

B13 – Allergy to crustacean and molluscs

Sandip D. Kamath, Roni Nugraha, Dianne E. Campbell, Andreas L. Lopata

Highlights

- Tropomyosin and arginine kinase are highly cross-reactive allergens and are responsible for clinical cross-reactivity among crustaceans, molluscs, insects, and mites.
- Some shellfish allergens can sensitize via the oral and inhalation route (tropomyosin, arginine kinase, triosephosphate isomerase, hemocyanin).
- There is a need for the incorporation of component allergen testing for mollusc allergy.

1 – The allergen sources

The shellfish group is included among the “Big Eight” food groups, which are responsible for more than 90% of all food allergy cases. It is estimated that up to 3% of the population are affected by food allergy to shellfish, including the crustacean and mollusc groups, depending upon geographical region.^{1015,1018} Shellfish allergy, particularly to shrimps, has one of the highest rates of food-induced anaphylaxis with nearly 42% of shellfish allergic adults and 12–20% of allergic children reporting anaphylaxis.^{1046,1047}

It is noteworthy that although shellfish, along with fish are commonly termed as seafood, these two groups are very distinct in evolutionary terms and contain different molecular repertoires of food allergens. All shellfish species are invertebrate animals, in contrast to fish, which are regarded as lower vertebrates. Aquatic animals of other phyla have not been investigated comprehensively regarding allergy due to limited consumption (e.g., jellyfish) and hence are not discussed in this chapter. The culinary term “Shellfish” combines two major invertebrate groups, which are taxonomically very different, the crustaceans and the molluscs. The edible crustaceans belong to the subphylum Crustacea and more specifically to the order Decapoda, which can be broadly grouped into shrimps (prawns), crabs and lobsters. While “shrimps” and “prawns” belong to two different taxonomical classifications, the terms are often used interchangeably commercially and in research publications (Figure 92). The Mollusca is the second largest phylum with over 100 edible species recorded by the Food and Agriculture Organization (FAO). The three most important subphyla in terms of consumption include the Gastropoda (e.g., abalone, snail), Bivalvia (e.g., mussel, oyster) and Cephalopoda (e.g., squid, cuttlefish). Comparing evolutionary distance, crustaceans are placed closer to insects and arachnids but not molluscs, and this seems to be the major factor for molecular cross-sensitization and clinical cross-reactivity between crustaceans, house dust mites and insects.

These classifications are important for understanding clinical and immunological cross-reactivities. The allergenic proteins present in these shellfish species have frequently different isoforms and often present a challenge in allergen detection as well as accurate allergy diagnosis and management (see below). In addition, the availability and consumption of different shellfish species vary to a high degree in different parts of the world, with two-thirds of the global seafood production consumed in Asia.

Increased awareness of the high nutritional value of crustaceans and molluscs has led to a rise in shellfish consumption, and this has been associated with more frequent reported of allergic reactions. The following types of consumption and exposure can be potent elicitors of severe allergic reactions to shellfish;

A – Raw and cooked shellfish meat—Allergenic proteins are found in high concentrations in the edible muscle parts of shellfish. In crustaceans, it is found in the abdominal, tail and pincer meat. Food processing methods such as thermal or pressure treatment do not seem to denature most of the allergens but, on the contrary, may enhance their allergenic activity.^{1048,1676} The tropomyosin family represents the major heat-stable allergen present in all shellfish species, may constitute up to 20% of the total protein content and can be considered as a shellfish pan-allergen (see also Chapter C05). For food safety, food products containing shellfish must be appropriately labelled. Moreover, the European Union has mandated separate food allergen labelling for crustaceans and molluscs; however, appropriate tests are only available for crustaceans.¹⁰⁴⁹ Determining the eliciting dose of shellfish allergic reactions threshold distributions is important for the appropriate allergen labelling on seafood-based products. Recent studies have demonstrated that approximately 0.1–1.0 g of shellfish meat has to be ingested to trigger an allergic response.⁹⁸⁸ Of note, shrimp is estimated to have one of the highest ED50's (amount of allergic protein required to trigger an allergic reaction in 50% of sensitized individuals) of the “big 8” allergen groups, with about 8 g of shrimp protein (approximately half a shrimp).⁵⁵⁴ Only 1% of shrimp allergic individuals develop allergic reactions following exposures to 26 mg or more of shrimp meat. This high ED may explain variable clinical histories of tolerance to small ingested amounts, while subsequent severe reactions can be observed.

B – Food additives containing shellfish-derived proteins—Shellfish products such as dried shrimp or shrimp paste are widely used as flavouring agents in various packaged and processed foods such as instant noodles and soups. This may be a potential source and cause of accidental consumption and exposure to shellfish allergens (see Table 38 for food products indicating the presence of shellfish groups).

C – Occupational exposure—In the seafood processing industry, workers are constantly exposed to aerosolized shellfish particulate matters arising from different processing activities leading to the inhalation of airborne allergens and/or cooking fumes.¹⁰⁵⁰ Such occupational exposure to shellfish allergens may be a primary route of sensitization to shellfish, and upon re-exposure can elicit upper and lower respiratory tract symptoms such as cough, wheeze, laryngeal

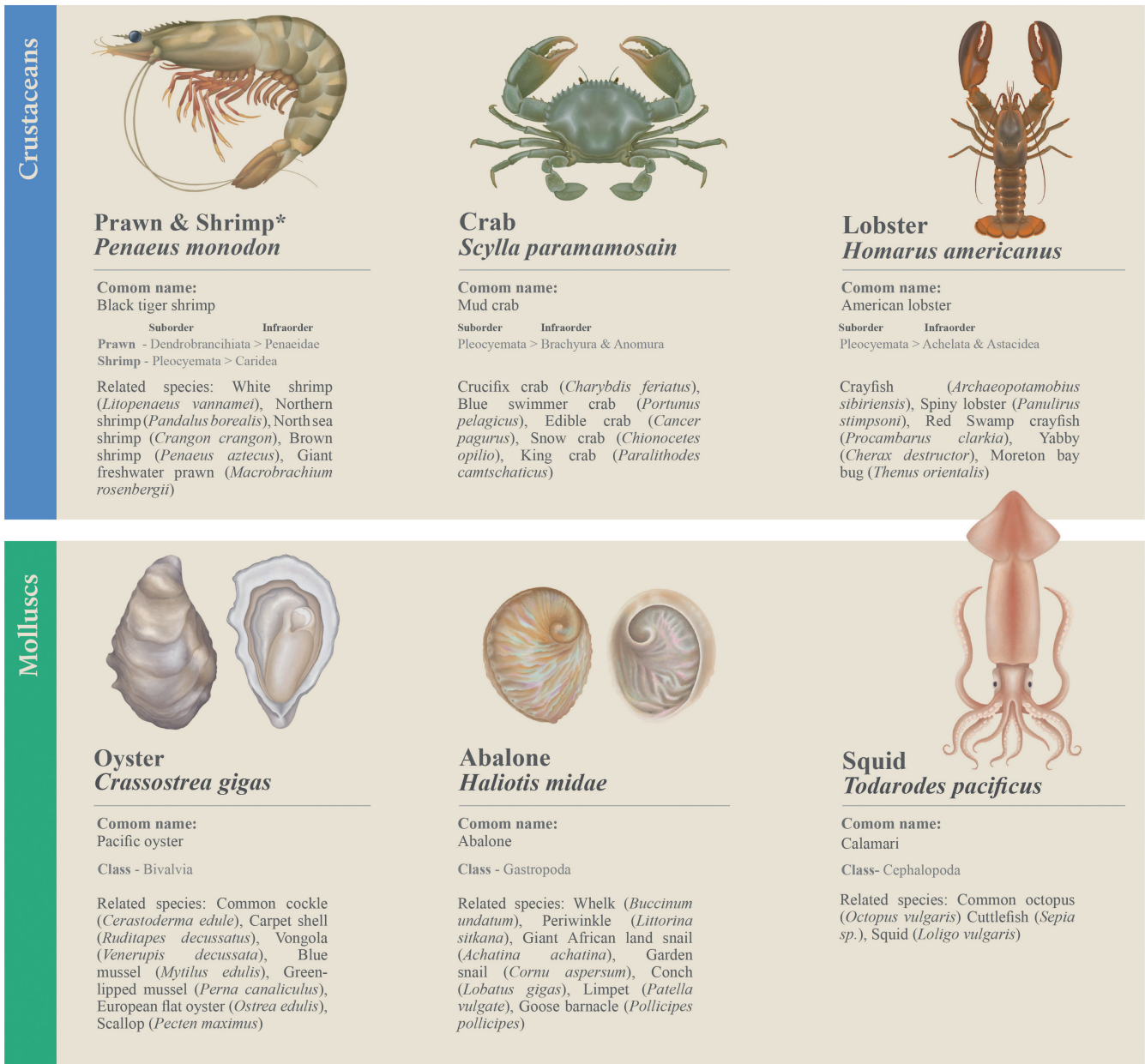


FIGURE 92 Classification of edible crustacean and mollusc species * The term prawn and shrimp are used synonymously or interchangeably in different regions. Taxonomically, they belong to different suborders of crustaceans.

symptoms, and rhinitis.¹⁰²³ Occupational exposure may also result in contact urticaria¹⁰⁵¹ or contact dermatitis.^{1052,1053} Workers with shellfish-induced occupational asthma are at risk of developing allergic reactions upon ingestion of seafood.¹⁰⁵⁴

D - Fish parasites -The food-borne parasite *Anisakis* or hering worm is an important food allergen source. *Anisakis* is a parasitic nematode that mainly infects fish, but also crustaceans and squid, and the ingestion of contaminated fish or shellfish can result in severe allergic reactions.¹⁰⁵⁵ More importantly, the allergens of the tropomyosin family are thought to be responsible for cross-reactivity between *Anisakis* and other invertebrates such as insects, mites and crustaceans.

2 - Allergen families

Edible shellfish species can be broadly categorized into crustaceans and molluscs (Figure 92). Crustaceans include prawns, shrimp, crab, lobster, and several other species. Molluscs include oysters, mussels, squid, octopus, and abalone. Although a few hundred different shellfish species are consumed worldwide, nearly 80% of all allergic incidences to shellfish are reported to shrimps or prawns. This is partly due to the high production and consumption rate in comparison to other shellfish species of commercial importance. Biologically, all edible shellfish species are invertebrates belonging to Arthropoda or Mollusca phyla. Naturally, most of the identified shellfish allergens

TABLE 38 List of ingredients that may contain allergenic Crustacean or Mollusc proteins

Crustaceans species that may be included as food ingredients
Barnacle, Balmain bugs, Crab, Crawfish, Crayfish, Krill, Lobster, Marron, Moreton bay bugs, Prawns, Shrimp (Crevette, Scampi), Yabbie
Mollusc species that may be included as food ingredients
Abalone, Barnacles, Clam, Cockle, Cuttlefish, Limpet, Mussel, Octopus, Oyster, Periwinkle, Sea cucumber, Sea urchin, Scallop, Snail, Squid (calamari), Whelk
Food preparations that may contain shellfish
Bouillabaisse, Cuttlefish Ink, Clam chowder, Clam broth base powder, Crab extract powder, Condiments and spices, Scallop extract powder, Fish stock, Fish Sauce, Glucosamine, Lobster extract powder, Marinara, Oyster juice powder, Paella, Pescatore sauce, Prawn crackers, Prawn chips, Shrimp powder, Seafood flavouring, Surimi, Squid ink,

belong to a common set of protein families that is shared across a diverse range of species.

Shellfish allergens currently identified belong mainly to the tropomyosin (Protein family, PF00261), EF-hand (PF00036), phosphotransferase (PF00217), triosephosphate isomerase (PF00121), fatty acid-binding protein (PF00061), and hemocyanin families (PF00372) (Figures 93 and 94). The major allergens found across all crustacean and mollusc species belong to the tropomyosin family. Multiple isoforms are found depending on function and location; for example, the fast-twitch or slow-twitch isoform is found in crab tail or pincer muscle respectively.

Allergens from the tropomyosin family have a highly conserved primary structure, and this is the main reason for immunological and clinical cross-reactivity not only among crustaceans and molluscs but also among insects, mites, and nematodes (Figure 95). Arginine kinase belongs to the phosphotransferase family while myosin light chain, sarcoplasmic calcium-binding protein, and troponin C belong to the EF-hand domain family. Interestingly, all identified shellfish allergens are proteins involved in cytoskeletal functions or metabolic enzymes (see Table 39).

Due to the complexity and heterogeneity of proteins among crustaceans and molluscs, the relationship between their structure and subsequent allergenicity has only partly been elucidated. In the past, mainly tropomyosin from many crustaceans and a few molluscs had been characterized in detail. The major allergen, tropomyosin was first identified in 1993 as the major shrimp allergen.¹⁰⁵⁶ Recently, fatty acid-binding protein, filamin C and hemocyanin have been identified and characterized as shrimp allergens. In addition, paramyosin was identified recently in whelk. In the past 10 years, five additional shellfish proteins have been identified to elicit IgE-mediated hypersensitivity through ingestion and inhalation and are now officially accepted by the IUIS Allergen Nomenclature Sub-Committee (Tables 39 and 40).

3 – Allergenic Molecules

As of 2021, 54 allergens from 20 crustacean and 8 mollusc species have been identified and registered on the WHO IUIS Allergen Nomenclature database, despite an even higher number of species and allergens described in the current literature. All of the currently

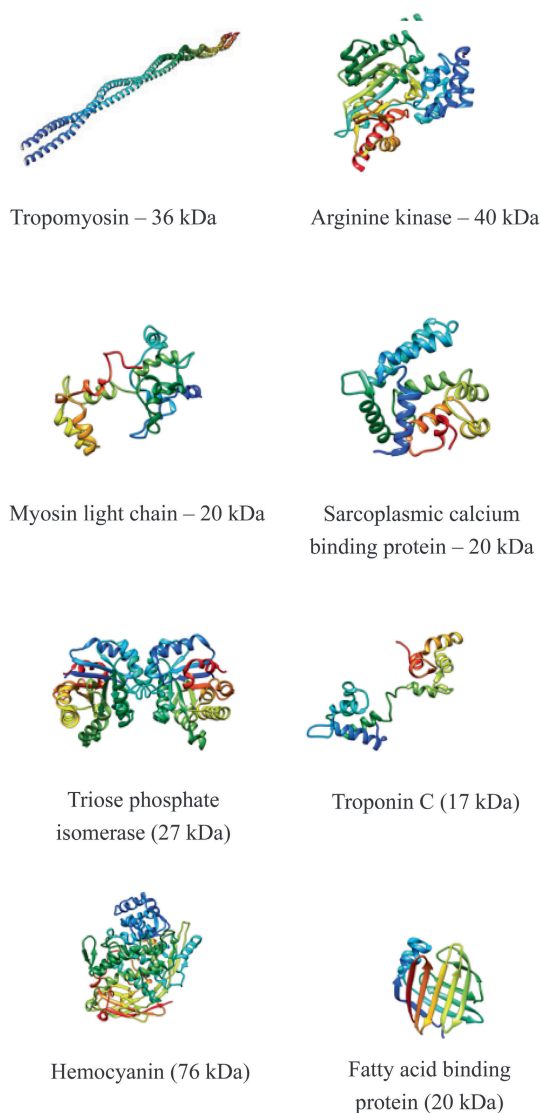


FIGURE 93 Three-dimensional structures of shellfish allergens currently identified and registered the WHO-IUIS Allergen nomenclature. The recently IUIS-registered Paramyosin and filamin C allergens are not depicted in this figure.

identified shellfish allergens demonstrate common properties such as low molecular weight (15–75 kDa), propensity to form a dimer or high oligomer, and good aqueous solubility (Tables 39 and 40).

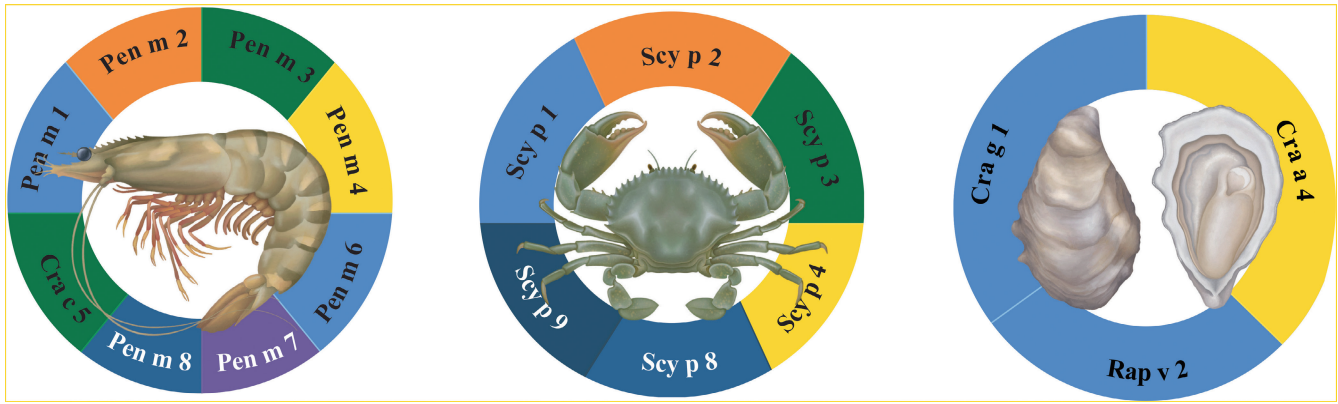


FIGURE 94 A summary of the different crustacean and mollusc allergens identified and registered in the WHO/IUIS Allergen nomenclature database. Allergens belonging to a common protein family are highlighted in the same colour.

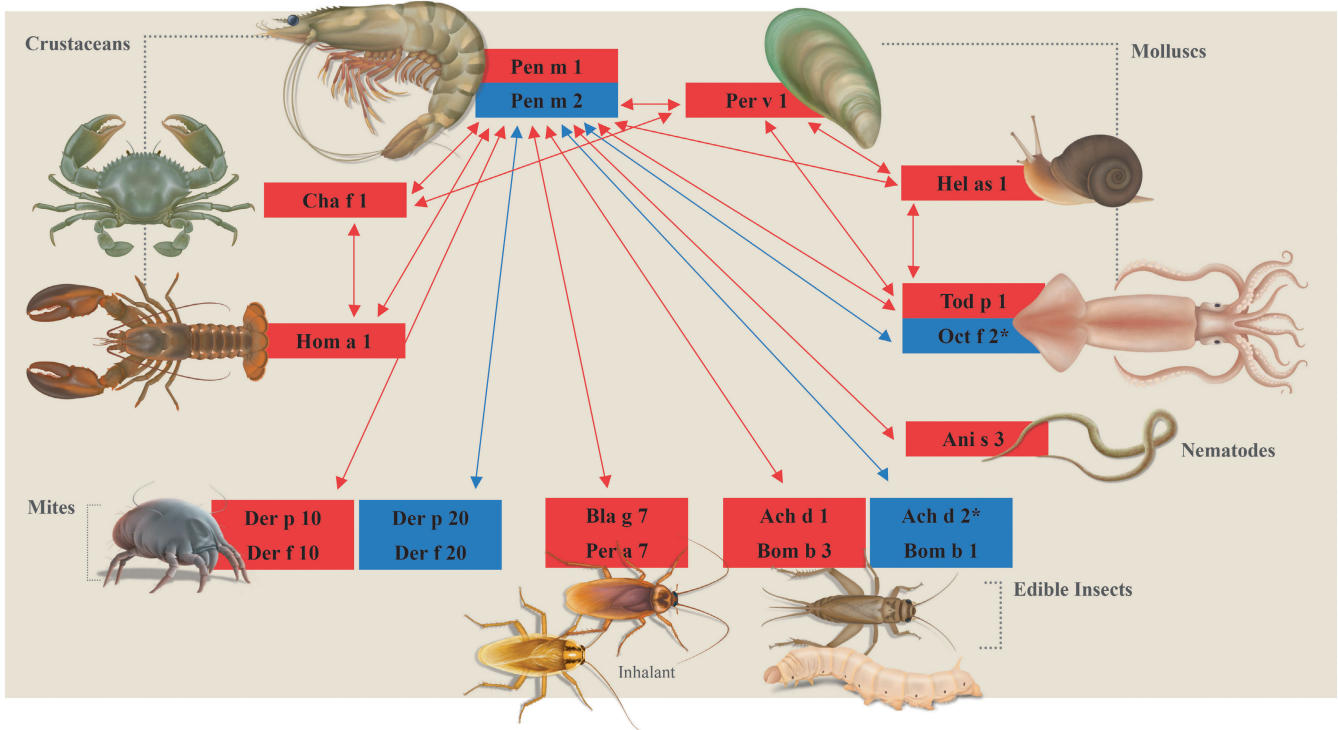


FIGURE 95 Clinically relevant cross-reactivities between shellfish (crustacean and mollusc) and invertebrate (mite, insect, and nematode) allergens. Cross-reactivity due to different allergen families is depicted in red (tropomyosin) or blue (arginine kinase) arrows. * indicates allergens that are not currently registered in the WHO-IUIS Allergen nomenclature database.

Tropomyosin is an alpha-helical coiled-coil protein that interacts with actin filaments in muscle and nonmuscle cells. Present mainly in the edible meat, it is one of the most abundant proteins representing up to 20% of the total protein content in a shrimp. This allergen is shown to be highly heat stable and relatively resistant to proteases. Several studies have shown that tropomyosin is the prime cause for IgE cross-reactivity among shellfish, insects (including edible insects) and mite species. Interestingly, recent studies have indicated

that tropomyosin may not show T-cell cross-reactivity as a function of structural stability.¹⁰⁵⁷

Arginine kinase has been identified in several crustaceans and one mollusc species. Arginine kinase is a phosphotransferase that catalyzes the reversible transfer of the phosphoryl group from ATP to arginine, yielding ADP and N-phosphoarginine. In higher vertebrates, creatinine kinase catalyzes this reaction. Recent studies have shown that arginine kinase is susceptible to heat treatment or

TABLE 39 Allergenic molecules present in crustacean species and registered in the WHO/IUIS Allergen Nomenclature database

	Species frequently implicated	Allergenic name (IUIS)	Biochemical name	Molecular weight	Heat stability	Physiological function	Route of exposure
1	<i>Penaeus monodan</i> (black tiger prawn) <i>Litopenaeus vannamei</i> (white leg shrimp)	Cha f 1, Cra c 1, Hom a 1, Lit v 1, Mel l 1, Met e 1, Pan b 1, Pen m 1, Por p 1, Scy p 1	Tropomyosin	34-38 kDa	Highly heat stable	Muscle contraction	Ingestion Inhalation
2	<i>Penaeus aztecus</i> (Brown shrimp)	Cra c 2, Lit v 2, Pen m 2, Scy p 2	Arginine kinase	40-45 kDa	Stable	Energy metabolism in muscles	Ingestion Inhalation
3		Hom a 3, Lit v 3, Pen m 3, Cra c 5, Scy p 3	Myosin light chain	17-20 kDa	Stable	Muscle contraction	Ingestion
4	<i>Homarus americanus</i> (American lobster)	Cra c 4, Lit v 4, Pen m 4, Scy p 4	Sarcoplasmic calcium binding protein	20-25 kDa	Stable	Muscle contraction regulation	Ingestion
5	<i>Crangon crangon</i> (Sand shrimp)	Cra c 6, Hom a 6, Pen m 6	Troponin C	20-21 kDa	Unknown	Calcium-dependent activation of muscle contraction	Ingestion
6	<i>Charybdis feriatus</i> (Crucifix crab)	Pen m 7	Hemocyanin	75 kDa	Stable	Copper-containing Oxygen transport protein, anti-microbial property	Ingestion Inhalation
7	<i>Portnus pelagicus</i> (Blueswimmer crab) <i>Scylla paramamosain</i> (Mud crab)	Arc s 8, Cra c 8, Scy p 8 Pen m 13	Triose-Phosphate isomerase Fatty-acid binding protein	28 kDa 20 kDa	Labile Unknown	Glycolysis (energy metabolism) Transport protein for lipophilic molecules (fatty acids)	Ingestion Inhalation Ingestion

thermal food processing. This is an important fact to consider while using *in vitro* diagnostics often based on heated shrimp or crab extract to avoid bacterial contamination and therefore include mainly heat-stable proteins; component resolved diagnostics might offer a better solution. Arginine kinase has been implicated in cross-reactivity between shellfish and edible insects.⁹³⁷

Myosin light chain (MLC), troponin C & I, and sarcoplasmic calcium-binding protein (SCP) are EF-hand domain proteins. All have been identified in several crustacean species but only SCP is identified in molluscs. Similar to tropomyosin, MLC and troponin C are involved in muscle function. SCP, similar to parvalbumin, is a calcium-binding protein regulating cytosolic calcium concentration. Hemocyanin was first identified as an allergen in the giant freshwater shrimp. **Hemocyanins** are copper-containing, oxygen transport proteins mainly found in the hemolymph of invertebrate animals. Consumption of cephalothorax is common in Asian populations and could lead to higher exposure to this allergen.¹⁰⁵⁸ The 75 kD subunits create a hexameric structure for their physiological

function. Hemocyanins-derived peptides are also known to have anti-microbial properties.¹⁰⁵⁹ Hemocyanin (Pen m 7) from Black tiger prawn was recently registered as a shrimp allergen. A recent study evidenced the presence of more than 10 different isoforms in Black tiger prawn hemolymph.¹⁰⁶⁰

Triose-phosphate isomerase is a glycolytic 28 kDa protein that, catalyzing the conversion of dihydroxyacetone phosphate to glyceraldehyde 3-phosphate. It has been identified not only in shrimps and crayfish but also in cockroaches.

Fatty acid-binding protein is a 20 kDa protein that belongs to a family of intracellular transport proteins for fatty acids, eicosanoids, retinoids, and other lipophilic molecules. This protein was recently registered as a shrimp allergen; Pen m 13. The thermal stability and presence of this protein in heated shellfish extracts are not known.

Additional IgE-binding proteins have been identified and partially characterized in crustacean and molluscs, including myosin heavy chain, pyruvate kinase, enolase, and paramyosin, but not yet registered with the WHO/IUIS.¹⁰⁶¹

TABLE 40 Allergenic molecules present in mollusc species and registered in the WHO/IUIS Allergen Nomenclature database

	Species frequently implicated	Allergenic name (IUIS)	Biochemical name	Molecular weight	Heat stability	Physiological function	Route of exposure
1	<i>Haliotes midae</i> (Abalone)	Hel as 1, Hal m1, Tod p 1	Tropomyosin	34-49 kDa	Highly heat stable	Muscle contraction	Ingestion Inhalation
2	<i>Helix aspersa</i> (Garden snail)	Rap v 2	Paramyosin	99 kDa	Unknown	Muscle contraction	Ingestion
3	<i>Todarodes pacificus</i> (Flying squid) <i>Amphioctopus fangsio</i> (Octopus)	Unassigned	Arginine kinase	40-45 kDa	Stable	Energy metabolism in muscles	Ingestion Inhalation
4	<i>Crassostrea gigas</i> and <i>Crassostrea angulata</i> (Pacific oyster)	Unassigned	Actin	42 kDa	Heat - Labile	Muscle contraction	Ingestion
5	<i>Fulvia mutica</i> (Cockle)	Cra a 4	Sarcoplasmic calcium binding protein	20-25 kDa	Unknown	Muscle contraction regulation	Ingestion

4 – Sensitization to individual molecules and their clinical relevance

Previously published sensitization rates to shellfish were based predominantly on skin or IgE testing to whole shellfish extracts.^{335,1062}

Studies have estimated the prevalence of shellfish allergy to be up to 3% in the adult population.^{1018,1063} In the Asia-pacific region self-reported rates of shellfish allergy in children range from 0.9%-1.19% among 7 years or below, and 5.12%-7.71% in adolescents and adults.

Allergen-specific IgE sensitization to various shellfish allergens have been demonstrated (Table 41). In general, 60% of individuals with confirmed allergy to shellfish elicit specific IgE binding to tropomyosin. More importantly, it has been demonstrated that serum-specific IgE to tropomyosin is a better predictor of shrimp allergy than shrimp SPT or IgE to whole shrimp extract.^{1064,1065} Tropomyosin (Pen m 1) and sarcoplasmic calcium-binding protein (Pen m 4) sensitization has been associated with clinical reactivity to shrimp allergy.¹⁵ However, the sensitization profile to specific allergens can differ geographically. For example, sensitization to tropomyosin seems to be much lower in Asian countries, and this could be due to eating habits where in addition to the shellfish muscle tissue other parts are consumed, including the cephalothorax that is rich in enzymatic proteins and hemocyanin.¹⁰⁶⁷

Notably, conclusions on true sensitization rates are hampered due to the highly cross-reactive nature of some shellfish allergens. The tropomyosin allergen group among the crustaceans demonstrates very strong clinical cross-reactivity (see Figure 95 and chapter C05), likely due to the high amino acid homology, with over 95% among all currently analyzed shrimps, crabs and lobsters. For example, 75% of shrimp allergic patients elicited immunological IgE cross-reactivity to crab tropomyosin Por p 1.¹⁰⁶⁸

By contrast, there is very limited information about tropomyosin among the mollusc group. This allergen from various mollusc species such as abalone, mussel, oysters, squid and cockle can have amino acid homologies as low as 70%, and even lower when compared with crustacean tropomyosin Por p 1.¹⁰⁶⁸

This can result in limited clinical cross-reactivity of allergic patients as demonstrated in a study where 54% of the recruited patients anaphylactic to crustaceans were tolerant to molluscs.¹⁰⁶⁹ Myosin light chain and Sarcoplasmic calcium-binding protein have a lower IgE-binding frequency; however, a higher rate of IgE sensitization is observed in children as compared to adults and may be used as diagnostic markers for shrimp allergy in children.^{15,1066,1677} IgE sensitization to shrimp hemocyanin has been reported to be 29% in DBPCFC-confirmed shrimp allergic patients¹⁵ and 40% in a Spanish population.¹⁰⁷⁰ In a recent study, strong IgE sensitization to crab hemocyanin was observed in crab-processing workers by inhalational exposure to aerosolized matter.¹⁰⁷¹ Therefore, hemocyanin-specific IgE may be a potential diagnostic marker for occupational exposure and symptoms to shellfish allergens.

5 – Clinical Management

Patterns of initial sensitization

IgE-mediated allergy is most likely the most common form of adverse reactions to shellfish; however, reliable population-based epidemiological studies are lacking. As recently reviewed by Cox et al, based upon most observational cohorts and case series, it would appear that prevalence of shellfish allergy generally follows shrimp/ prawn > lobster > crab > mollusc, although this may be confounded by first exposures and subsequent avoidance of other types of shellfish.¹⁰⁷² As

TABLE 41 Clinical relevance and IgE sensitization to allergenic molecules in crustaceans

IgE Sensitisation	Reference	Allergenicity (FC and SPT)	Risk factor
Tropomyosin (TM)			
Pen a 1 51% (total 45 subjects)	[1678]	61% (24 subjects)	Ingestion
Lit v 1 94% (34 children)	[1085]	37% (45 subjects)	Inhalation
61% (19 adults)		sIgE to tropomyosin is a better	Occupational exposure
Pen m 1 62% (16 subjects)	[1048]	predictor of shrimp allergy than	
Cra c 1 68% (31 subjects)	[1679]	shrimp SPT or sIgE to whole	
		shrimp	
71% (35 subjects)			
Arginine Kinase (AK)			
Pen m 2 50% (16 subjects)	[1048]	Not known	Ingestion
Lit v 2 67% (34 children)	[1085]		Inhalation
21% (19 adults)			Occupational exposure
Cra c 2 29% (31 subjects)	[1679]		
Myosin light chain (MLC)			
Pen m 3 31% (16 subjects)	[1048]	Not known	Ingestion
Lit v 3 70% (34 children)	[1085]		
31% (19 adults)			
Cra c 3 19% (31 subjects)	[1679]		
Sarcoplasmic calcium binding protein (SCBP)			
Pen m 4 19% (16 subjects)	[1048]	sIgE to SCBP may be a better	Ingestion
Lit v 4 59% (34 children)	[1085]	predictor of shrimp allergy in	
31% (19 adults)		children	
Cra c 4 19% (31 subjects)	[1679]		
Troponin C (TnC)			
Cra c 6 19% (31 subjects)	[1679]	Not known	Ingestion
Triose phosphate isomerase (TIM)			
Pen m 8 19% (16 subjects)	[1048]	Not known	Ingestion
Cra c 8 23% (31 subjects)	[1679]		Inhalation
Hemocyanin			
29% (58 subjects)	[1048]	Not known	Ingestion
47% (40 subjects)	[1679]		Inhalation

previously described, initial sensitization to shellfish may arise from initial oral exposure or from occupational exposure, which may be airborne (via the respiratory tract), or cutaneous (via antigen-presenting cells resident in the dermis and epidermis) (see also Table 42). In addition, it is postulated that as cockroaches and house dust mites also have allergenic tropomyosin, sensitization and allergy to shellfish may occur via primary sensitization to an insect in some individuals.^{1072,1073}

Non-IgE-mediated allergy to shellfish is also described, most commonly in the form of Food Protein-Induced Enterocolitis Syndrome

(FPIES).¹⁰⁷⁴ Shellfish is also a known trigger of IgE-mediated food-dependent exercise-induced anaphylaxis (FDEIA), whereby the combination of exercise and ingestion is required to trigger an allergic reaction. Subjects with FDEIA tolerate shellfish food in the absence of exercise. In several regions, including Japan, shellfish is the second most common trigger of FDEIA, after wheat.¹⁰⁷⁵

Clinical manifestations

In the most common manifestations of IgE-mediated shellfish allergy, symptoms occur within minutes to 2 hours following ingestion

TABLE 42 Characteristics of shellfish allergy

	Ingestion	Inhalation	Contact
Routes of sensitisation (IgE specific response)	1. Gastro-intestinal uptake and subsequent IgE sensitisation to stable shellfish allergens 2. Gastro-intestinal uptake of shellfish allergens and subsequent IgE cross-reactivity to shellfish or fish parasite allergens	1. Inhalation of air-borne particulate shellfish matter and subsequent IgE sensitisation to allergens tropomyosin and arginine kinase 2. Ingestion-induced IgE sensitisation and subsequent inhalation related cross-reactivity to dust mite or insect tropomyosin	1. Primary uptake and IgE sensitisation to shellfish allergens through IgE receptors on epidermal Langerhans' (dendritic) cells 2. IgE sensitisation to shellfish proteins via gastro-intestinal or inhalational route and subsequent IgE reactivity on skin contact
Affected age group	children/adolescents/ adults	adolescents / seafood processing workers/restaurant workers	children/ adolescents/ adults/ seafood processing workers/ restaurant workers
Shellfish allergens involved	TM (Pen m 1), AK (Pen m 2), MLC (Pen m 3), SCP (Pen m 4), TnC (Pen m 6), TIM (Pen m 8), HC (Pen m 7), FABP (Pen m 13)	Tropomyosin, Arginine kinase	Not known
Allergen abundance	High in fresh and cooked meat and related products	Moderate to high in aerosol allergen content of Pen m1 and Pen m2 near cooking stations	Not known
Thermal stability	Very high stability	High	High
Prevalence	2% adults 0.9% children	4-36% among shellfish process workers	65% among shrimp workers (irritant or allergic origin)
Elicitors	Fresh or cooked shellfish meat. Processed foods containing shellfish	Air-borne shellfish bio-matter and cooking vapours	Wet aerosols, splash on hands and face
Symptoms	Generalized reactions (anaphylaxis), cutaneous (urticaria, angioedema, atopic dermatitis), gastrointestinal (pain, nausea, diarrhoea, vomiting), oral allergy syndrome	Upper and lower respiratory tract symptoms: asthma. Ocular-nasal symptoms: rhinitis, conjunctivitis	Contact dermatitis, urticaria, eczema
Medical diagnosis	Mild, Moderate to severe food allergic reaction to shellfish proteins	Mild, Moderate to severe respiratory symptoms which may lead to ingestion induced food allergy to shellfish proteins	Contact dermatitis and urticaria due to primary sensitisation to shellfish proteins
Type of food allergy	Type I – immediate onset	Type I – immediate onset	Type IV – delayed onset
Avoidance/Technical solution	No oral intake of crustacean or mollusc products, even small amounts	Mild, Moderate to severe respiratory symptoms which may lead to ingestion induced food allergy to shellfish proteins	Use of hand gloves and facemask for protection
Product declaration	Mandatory on each shellfish containing protein. Separate for crustaceans and molluscs (EU legislation)		

and are well known to clinicians. Allergic individuals who are primarily sensitized via oral exposure are at risk of respiratory symptoms through inhalation of cooking fumes. Likewise, individuals who have been sensitized in an occupational setting are at risk of both symptoms on further respiratory exposure, and by ingestion. Sensitizing allergens in occupational settings comprise mostly heat-stable allergens (e.g., tropomyosin and arginine kinase). In this setting, cross-reactivity among members of the crustacean group is more common than among molluscs.

IgE sensitization can also evolve from exposure to different crustacean or mollusc species resulting in various degrees of cross-reactivity, prompting severe clinical symptoms after ingestion of unrelated shellfish products. These reactions have mainly been described in adults but also reported in children. Skin exposure to heated and unprocessed shellfish induce IgE-mediated sensitization to shellfish allergens with subsequent inhalant and ingestion allergies in exposed individuals.¹⁰⁵⁴ In food-dependent exercise-induced anaphylaxis (FDEIA) triggered by shellfish, several recent reports have attempted to identify the culprit allergens at a molecular level. 70-kDa and 43-kDa Tris-soluble proteins identified as P75 homologue and fructose 1,6-bisphosphate aldolase (FBPA) were speculated to be the sensitizing molecules.¹⁶⁸⁰ In FPIES, the clinical presentation is distinct from that of typical IgE-mediated symptoms and comprises of onset of profuse vomiting, typically between 1-3 hours after ingestion. Other typical features include diarrhoea, pallor, floppiness (in infants and young children), hypothermia and hypotension. Although typically described in young infants, shellfish and fish FPIES appears to be the most common form of FPIES in adults.¹⁰⁷⁶ The specific allergens responsible for shellfish FPIES are yet to be identified.

Clinical Cross-Reactivity

Clinical cross-reactivity among crustaceans, between crustaceans and molluscs, as well as between crustaceans and mites or cockroaches, is largely considered due to the high homology of several allergens, as discussed above. Based upon several case series, it was reported that approximately 45% of individuals with a crustacean allergy are also mollusc allergic, and between 70-80% of individuals who report mollusc allergy has also experienced allergic reactions to crustaceans.^{1062,1077} Individuals who appear allergic to only particular species of shrimp have also been reported, and exactly what determines an individual's likelihood of clinical cross-reactivity has not been established.^{1078,1079} To that point, more focus has been on the allergen tropomyosin, where several linear and conformational epitopes have been reported, which might help to define these patterns of cross-reactivity.¹⁰⁸⁰ Using a large directory of 96 shrimp tropomyosin IgE-binding epitopes, it was demonstrated that over 50% of the epitopes were conserved between shrimp, cockroach and mite tropomyosins.¹⁰⁸¹ By contrast, less than 20% were conserved across different molluscs, supporting the observation that less than 50% of individuals with crustacean allergy cross-react to a mollusc. Based on this epitope analysis a decision tree to diagnose molecular cross-reactivity to crustacean and mollusc tropomyosins has been developed.¹⁰⁸² Although incompletely defined, recognition of epitopes and allergens appears to

differ between shellfish allergic children and adults.¹⁰⁸⁵ True rates of clinical cross-reactivity between crustaceans and molluscs are unknown, and to date, there are no specific biomarkers or molecular diagnostics, which can reliably identify such individuals. It is postulated that developments in epitope mapping may assist in this regard.

Natural History

The natural history of IgE-mediated allergy to shellfish is not well described. Attainment of tolerance once allergic is not common, and unlike most other food allergies, although well described in childhood, onset in adulthood appear more frequent than with other foods.^{1063,1077,1084} Likely due to high homology, most individuals allergic to one type of crustacean (shrimp, lobster, crab) will also react to other crustacea. Regarding FPIES to shellfish in adults, limited data suggest that adult FPIES is characterized by a significant delay in diagnosis and a prolonged course. Likewise, children appear less likely to attain tolerance to shellfish.^{1063,1085}

Diagnosis

Specific targeted clinical questions related to the history of exposure, interpretation of sensitization tests (e.g., SPT, IgE) and food challenges (open or blinded) help to establish the diagnosis of shellfish allergy. Following workup (Figure 96) may facilitate a correct diagnosis. It is also important to consider that the symptoms elicited upon shellfish exposure may have been not directly related to the shellfish, such as *anisakis* simplex allergy, or in the case particularly of mussels and oysters, paralytic shellfish /diarrhoetic shellfish poisoning, which are caused by shellfish contaminated with algae producing toxins. Here, symptoms typically occur within 2 to 3 hours of ingestion and include tingling of the lips, tongue and throat, nausea, headache and fever, and are clinically quite distinct for a typical IgE-mediated allergic reaction.

In terms of seeking a history to establish or assist in confirming a diagnosis of shellfish allergy, the following framework can assist in gathering the essential information required to assist with diagnosis, which includes history, route of exposure, any relevant cofactors and/or relevant cross-sensitization (such as house dust mite/insects).

Skin prick test (SPT)

Commercial whole shellfish extracts are available and provide reasonable results in situations where the allergen responsible is a highly abundant allergen such as tropomyosin but are limited value due to false-negative reactions in case of heat-sensitive allergens (e.g., MLC; hemocyanin) or weak or non-cross-reactive allergens (e.g., arginine kinase). Lack of availability of commercial extracts for specific shellfish species consumed by the patient (e.g., Asia-pacific and Southern hemisphere).

Prick-to-prick tests using fresh shellfish (with suspected offending food) are commonly performed; however, there are no established positive and negative predictive values for determining the likelihood of clinical allergy based upon the results. In addition, fresh shellfish SPT should be performed with caution and in a setting experienced in the recognition and management of anaphylaxis, as the test itself is reported to be able to trigger anaphylaxis in sensitive individuals.

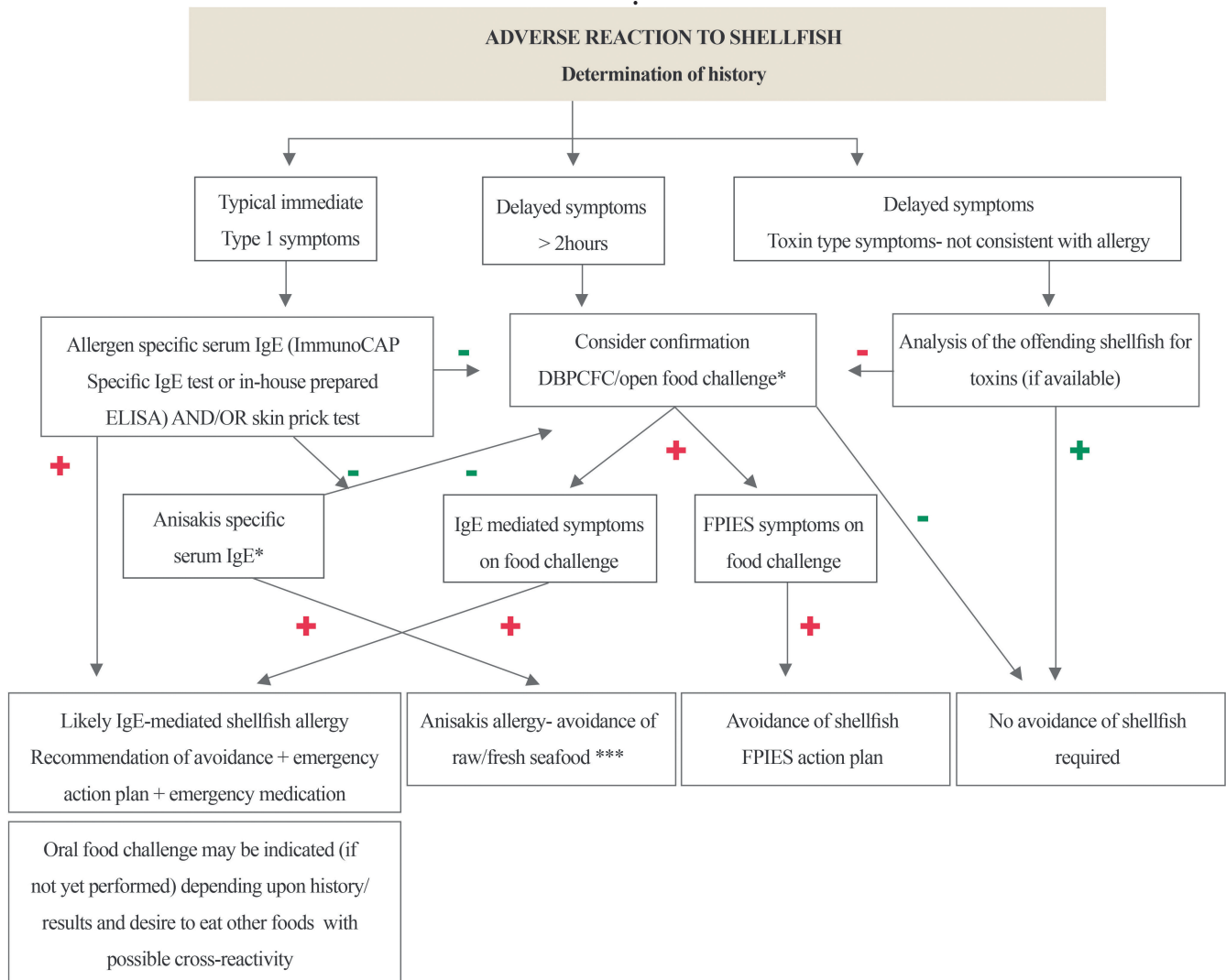


FIGURE 96 Diagnostic algorithm for shellfish allergy

* More common in fish/mollusk than crustaceans

**Consider exercise food challenge if history is suggestive of exercise related reaction and tolerance in other settings

*** Cooking at temperatures above 60°C or storage in industrial freezers for 2 days is required to kill the parasite.

Few studies have attempted to define a 95% PPV for SPT to shellfish in predicting clinical allergy based upon food challenges. A mean wheal diameter >20mm using commercial shrimp extracts and prick-to-prick was reported to provide 95% PPV in a cohort from Thailand; however, many shrimp allergic subjects do not have SPT this large, potentially limiting the value of a PPV this high.¹⁰⁷⁹

Allergen-specific IgE

Whole Shellfish extracts are commonly used, however do not have high sensitivity or specificity, and the positive predictive value of such tests appear to vary depending upon the region. Thalayasingam et al. reported shrimp-specific IgE by ImmunoCAP ISAC had relatively poor overall test performance, with a sensitivity of 62% and a specificity of 50% for detecting shrimp allergy in a Singapore based cohort of food challenge confirmed shrimp, allergic individuals.¹⁰⁸⁶ In addition, with the use of whole allergen extracts, there is the potential for false-negative or low titers in individuals

sensitized to low abundant allergens (such as triosephosphate isomerase). Moreover, in some situations, allergen extract does not represent the specific shellfish species consumed by the patient and may result in false-negative results (e.g., Southern versus Northern hemisphere).

Relevant major allergens are detailed in Table 43; however, they have limited commercial availability for routine diagnostics. Some purified allergens from shrimps, house dust-mite and *anisakis* are available on the allergen microchip (ImmunoCAP ISAC (Thermo Fisher Scientific); Alex (Macro Array Diagnostics) and used to quantify allergen-specific IgE. The reported sensitivity of tropomyosin varies significantly in the literature, with some reports as high as 71–88%. In a small selected cohort, tropomyosin specific IgE was found to be more specific for the diagnosis of clinical shrimp allergy than IgE to whole extract or SPT (with similar sensitivity across all three methods).¹⁰⁶⁵ These results contrast with that of Thalayasingam

TABLE 43 Currently available *in vitro* and skin prick tests for diagnosis of crustacean or mollusc allergy

Sub-group	Whole extract	Component allergens	SPT (test code)
Crustaceans			
Prawns, Shrimp	Shrimp- Black tiger prawn (<i>Penaeus monodon</i>), Northern shrimp (<i>Pandalus borealis</i>), Velvet prawn (<i>Metapenaeopsis barbata</i>), Shiba shrimp (<i>Metapenaeus joyneri</i>) (ImmunoCAP, f24), Northern prawn (<i>Pandalus borealis</i>) (MADx, f515), Shrimp mix (<i>Litopenaeus setiferus</i> , <i>Farfantepenaeus aztecus</i> , <i>Farfantepenaeus dourarum</i>) (MADx, f24)	Pen a 1 (<i>Penaeus aztecus</i>) (ImmunoCAP, f351), nPen m 1 (Tropomyosin) (ImmunoCAP ISAC) nPen m 2 (Arginine kinase) (ImmunoCAP ISAC), nPen m 4 (Sarcoplasmic calcium-binding protein) (ISAC), nPen m 1 (Tropomyosin) (MADx, f517), rPen m 2 (Arginine kinase) (MADx, f545), rPen m 3 (Myosin light chain) (MADx, f552), rPen m 4 (Sarcoplasmic calcium-binding protein) (MADx, f524), rCra c 6 (Troponin C) (MADx, f529)	Shrimp (6.89) ALK-Abello, Soluprick (<i>Pandalus borealis</i>) Shrimp (SHRI) ALK-Abello (<i>Penaeus spp.</i>) Shrimp (120) Stallergenes, Shellfish, mix (MISH) (crab, shrimp, lobster, oyster) ALK-Abello Shellfish Mix 4 (SHM4) (crab, clam, lobster, shrimp)
Crabs	Crab Edible crab (<i>Cancer pagurus</i>) (ImmunoCAP, f23), Crab (<i>Chionocetes</i> <i>spp.</i>) (MADx, f23)		Crab (6.9) ALK-Abello, Soluprick (<i>Cancer pagurus</i>) Crab (CRAB) ALK-Abello (<i>Paralithodescantschaticus</i>)
Lobsters	European Lobster (<i>Homarus gammarus</i>) (ImmunoCAP, f80), (MADx, f80), Spiny Lobster (<i>Panulirus vulgaris</i>) (ImmunoCAP, f304), Crayfish (<i>Astacus astacus</i>) (ImmunoCAP, f320)		Lobster (LOBS) ALK-Abello (<i>Panulirus spp.</i>) Spiny lobster (131) Stallergenes
Bivalves	Blue mussel (<i>Mytilus edulis</i>) (ImmunoCAP, f37) (MADx, f37), Oyster (<i>Ostrea edulis</i>) (ImmunoCAP, f290), (MADx, f290), Clam (<i>Ruditapes spp.</i>) (ImmunoCAP, f207), (MADx, f207), Scallop (<i>Pecten spp.</i>) (ImmunoCAP, f338), (MADx, f338)		Oyster (OYST), ALK-Abello Mussel (139), Stallergenes Oyster (131), Stallergenes
Gastropods	Abalone (<i>Haliotis spp.</i>) (ImmunoCAP, f346), Snail (<i>Helix aspersa</i>) (ImmunoCAP, f314)		
Cephalopods	Squid (<i>Loligo vulgaris</i> , <i>Loligo edulis</i>) (ImmunoCAP, f258) (MADx, f258), Pacific squid (<i>Todarodes pacificus</i>) (ImmunoCAP, f58), Octopus (<i>Octopus vulgaris</i>) (ImmunoCAP, f59),		

et al, who reported a low sensitivity for tropomyosin-IgE for the challenge has proven shrimp allergy (by ImmunoCAP ISAC), at 34%.¹⁰⁸⁶ Specificity, however, was superior at 85.2%.

Overall, it has been reported that the reliability of specific IgE to the whole extract is similar to that of the SPT, whereby the identification of sensitization does not correlate with clinical reactivity

nor with symptom severity.¹⁰⁷⁷ Reactivity to tropomyosin may be more specific but appears variable in sensitivity across reports and geographical regions. Furthermore, there are no purified allergens available from molluscs for diagnosis.

For further interpretation of SPT and IgE outcomes see also (Figure 96 and Table 43).

Food Challenge

Double-blind placebo-controlled food challenges are the gold standard for confirming a diagnosis of shellfish allergy. In clinical practice, they are, however, usually performed in an open, rather than blinded manner and usually in the circumstances where there is some doubt over the relationship between shellfish ingestion and allergic reaction, or where the history appears consistent, but the SPT/sIgE are low/absent. They may also be performed (much like a fish allergy) in cases where a shellfish allergic individual is interested in consuming a potentially cross-reactive mollusc. There are a variety of proposed schedules for shellfish challenges, usually commencing at low mg quantities of food, and then proceeding at 15-20 minutely intervals with sequentially larger (often semi-logarithmic) increases in quantities until an objective allergic reaction is observed. A variety of full cumulative doses are recommended in published guidelines, and because of the ED distribution of shrimp, these tend to be significantly higher than those for cow's milk, egg or peanut (ranging up to 24 g of seafood, e.g., 1-2 large shrimps).⁵⁵⁴

Management and avoidance

Because of the high degree of likely clinically relevant cross-reactivity, it is generally recommended to avoid all shellfish containing products, even with small amounts, regardless of the grade of shellfish processing once a diagnosis of shellfish allergy has been made. Emergency action plans in case of severe reactions and personal adrenaline auto-injectors are recommended, along with avoidance of inhalation of shellfish containing protein cooking fumes/steam and vapours and touching or handling shellfish.

A common miscomprehension surrounds iodine and shellfish allergy. Individuals who are allergic to seafood are not at an increased risk of allergic reactions to iodine (e.g., topical antiseptics such as Betadine or Povidine or intravenous x-ray radio-contrast agents). Conversely, people with iodine allergy are not at increased risk of seafood allergy.

Allergen-specific immunotherapy

At present commercially available products for allergen-specific immunotherapy of shellfish protein allergy are not available.

6 – Clinical cases

Case 1 (published¹⁰⁸⁷)

History: 19-year-old male, developed hives, circumoral swelling and systemic symptoms—faintness, shortness of breath, vomiting, diarrhoea, and abdominal cramp after running. He was brought into the Emergency Department (EMD). He had consumed a home-cooked

meal containing shrimp before exercise. The patient also had rashes when ingesting clams. He had previously been able to eat large amounts of shrimps without any problems but could not recall if he had ever exercised directly after eating a large shrimp meal.

SPT: Negative to an extensive list of foods, including wheat and shrimp but positive to Der p, Der f, Blo t. sIgE-omega-5-gliadin negative
Diagnosis: Food-dependent exercise-induced anaphylaxis (FDEIA) triggered by shrimp.

Recommendation: Given adrenaline for anaphylaxis in ED. Must avoid shellfish 2 hours before or following strenuous exercise. In cases where the diagnosis is in doubt, an exercise challenge can be performed, both without any prior feeding (i.e., fasted) and then following consumption of a shrimp containing meal. Such challenges are complex and can potentially trigger severe anaphylaxis and should be performed carefully by staff and centres familiar with the procedures and with experience in the management of severe anaphylaxis.

Case 2 (published¹⁰⁸⁸)

History: 22-months old Latin-American male with a history of cow's milk allergy, reactive airway disease, and eczema and no history of allergic rhinitis symptoms. On ingestion of one shrimp, there was immediate swelling of eyes and hives on his face without difficulty in breathing. Symptoms subsided within 24 hours on the administration of diphenhydramine.

In-vitro testing: Serum-specific IgE showed levels of 12.6 kU/L to shrimp, 12.3 kU/L to milk, 0.55 kU/L to egg white, 0.72 kU/L to wheat, 0.41 kU/L to soybean, 0.61 kU/L to peanut, and <0.35 kU/L to codfish.

Recommendations: Strict avoidance of shrimp and other shellfish in his diet. Autoinjector epinephrine was prescribed. No further episodes of angioedema or hives were observed.

7 – Research and future perspectives

The diagnosis and management of shellfish allergy are complicated by several homologous, cross-reactive proteins, including tropomyosin and arginine kinase. This results in patients having allergic sensitization (positive test) to several crustacean and mollusc species, however, often without demonstrating clinical reactivity, hampering the identification of true sensitization rates to specific species. Future studies need to establish sensitization rates to different shellfish allergens in different geographic environments, as this will directly impact of sensitivity and specificity of different *in vivo* and *in vitro* tests. The impact of environmental exposure should be taken into account, as high exposure and sensitization rates to cockroaches and HDM could increase allergen-specific IgE reactivity. Further investigation into the cross-sensitization to pan-allergens such as tropomyosin from inhaled HDM and cockroach will provide greater insight into the pathogenesis of the mite-shellfish oral allergy syndrome. Further clinical research is needed to analyze the relationship between sIgE specific sensitization profiles to tropomyosin from different shellfish species and other

invertebrates, including HDM and insects. Advice on future dietary precautions based on molecular reactivity is currently difficult to provide to patients, without oral food challenges. There is an urgent need to identify more specific marker allergens for IgE testing to discriminate between poly- or mono-sensitized patients to the crustacean,

mollusc and other invertebrates. Advice for use of molecular diagnostics for crustacean and mollusc (1) Specific IgE to shrimp tropomyosin has a positive predictive value of 0.72 in the diagnosis of shrimp allergy. (2) Tropomyosin and sarcoplasmic calcium-binding protein sensitization are associated with clinical reactivity to shrimp.

B14 - Allergy to mammalian meat

Marianne van Hage, Tilo Biedermann, Christiane Hilger, Thomas A.E. Platts-Mills

Highlights

- Farm animals provide a major part of the diet in many parts of the world
- Sensitization to meat can be acquired through different routes (inhaled, oral, skin)
- New forms of allergic reactions to meat have been recognized (cat-pork and red meat)
- IgE assays including meat allergen sources and components will help identifying the patients
- The only effective treatment is avoidance of relevant meat sources

1 - The allergen sources

Meat derived from domesticated mammals has been an important part of the human diet for at least ten thousand years. The animal tissue sold and eaten as meat includes blood, fat, innards, and tendons, as well as muscles. There is inevitably some cross-reactivity with serum proteins and milk proteins from the same animal. Milk is relevant only for goats, sheep, and cows in the USA and Europe, but it is important to remember that camels and other animals are milked in some parts of the world.

TABLE 44 Animals contributing to meat consumption and reactions

Animals	Source	Milk	Allergen molecules* #	Alpha-gal Reactions
<i>Bos domesticus</i> (cow)	Farm	+++	Twelve (10) Bos d 2-13	Yes
<i>Sus domesticus</i> (pig)	Farm/feral	No	Albumin (1) Sus s 1	Yes
<i>Capra aegagrus</i> (goat)	Farm/D/Feral	++	None (0)	Yes
<i>Ovis aries</i> (sheep)	Farm	++	None (0)	Yes
<i>Equus caballus</i> (horse)	Farm	++	Six (2) Equ c 1-6	Yes
<i>Odocoileus virginianus</i> (deer)	Wild/Farm	No	None (0)	Yes
<i>Oryctolagus cuniculus</i> (rabbit)	Wild/D/Farm	No	Three (0) Ory c 2-4	Yes
<i>Cavia porcellus</i> (guinea pig)	D/Farm/wild	No	Five (0) Cav p 1-4,6	?

D= domesticated; *IUIS Allergen Nomenclature Sub-Committee at www.allergen.org; #Number in brackets indicates the number of allergens defined as food allergen. Alpha-gal is not included as single allergen in the table as the carbohydrate is basically present in all mammalian tissues and bound to many proteins

2 - Allergen families

Further, although there is a limited range of animals that are sold commercially in the west, a much larger variety of wild animals may be hunted and eaten in rural communities worldwide (Table 44). Farm animals provide a major part of the diet in western societies and in many other parts of the world. These animals are prized for their meat and organs (Figure 97). In addition, there are hundreds of forms of processed meat, including sausages, salami, bacon, etc. Meat also incorporates significant quantities of protein derived from serum, which includes many proteins that are recognized as allergens in cow's milk. Other products derived from these mammals include different forms of fat, paté, and gelatin, which is derived from tendons, cartilage, or skin.

3 - Allergen molecules, epidemiology and geographical variation

Initially the identification of meat derived allergens focused on protein antigens recognized by patients who reported allergic reactions that occurred rapidly after exposure. Most of these cases presented in childhood and many of the allergens were species specific proteins.^{951,1089} However, it was already clear that some mammalian proteins showed cross-reactivity between species, and this included both immunoglobulins and albumins.^{1083,1090} The most important allergens from beef, *Bos domesticus*, are serum albumin (Bos d 6), actin, myoglobin and immunoglobulin IgG (Bos d 7) (Tables 44 and 45) and of these, serum albumin and immunoglobulin are the major allergens.^{951,974,1083,1090} Beef-allergic children have been reported to

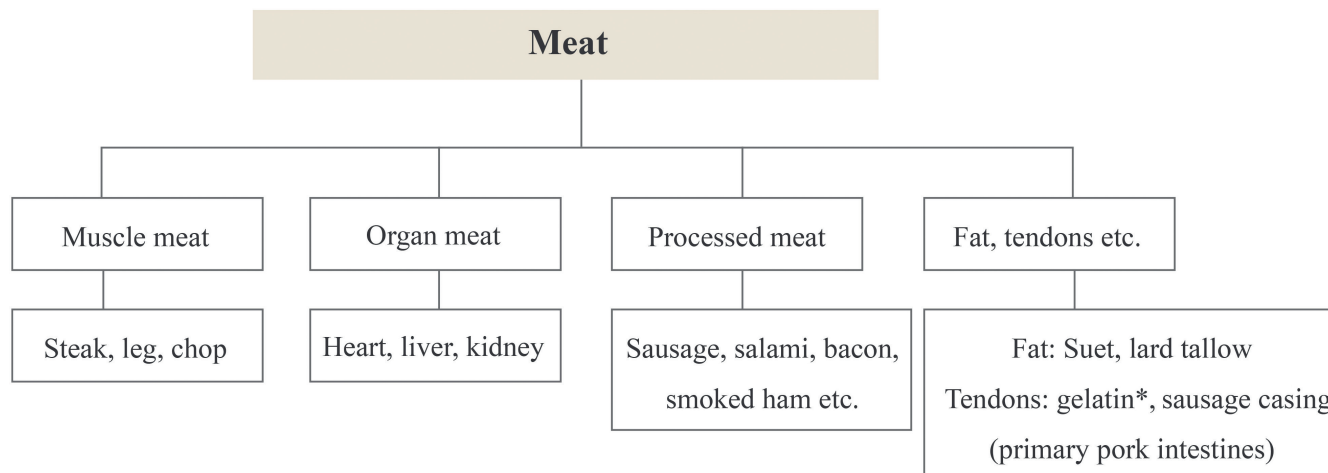


FIGURE 97 Any of these products can include serum proteins including proteins present in cow's milk (e.g., albumins, globulins, thyroglobulin) *Gelatin is made from tendons, cartilage, or skin and is a protein with varying quantities of glycosylation, used widely in food.

react to bovine serum albumin on SPT, but only some of them do so during challenge.⁹⁵¹

Despite the truly enormous quantities of meat eaten worldwide there are only a limited number of allergens defined (Table 44). Indeed, despite the extensive consumption of meat from sheep, goats and deer, there are no relevant allergens included in the IUIS database. Even for rabbit and guinea-pig, where there are 4 and 5 allergens, respectively, in the database, all of the defined allergens were recognized on the basis of inhalant symptoms. Thus, the only species with a significant number of food allergens recognized is the cow where ten of the allergenic proteins are recognized as food allergens. However, even in that case, most of the allergens were initially identified as allergens in cow's milk. Indeed, the majority of reported reactions to beef in childhood have occurred in cow's milk allergic children.^{951,974,1091} The same can occur with reactions to goat or sheep meat, with goat's milk or sheep milk as the primary sensitizer, but this is much less common. It is difficult to access the world literature on reactions to meat, because a large proportion of the populations eating goat and sheep have only primitive medical care. However, it is likely that the main meat proteins taken orally have very little allergenicity in man.¹⁰⁹²

In the last twenty years, two new forms of allergic reactions to meat have been recognized. In both of these syndromes, presentation is most often in adult life and in both cases the relevant allergens are characterized by extensive cross-reactivity between different mammals. First, it was recognized that some patients who had allergic reactions to pork, were reacting because of pre-existing IgE antibodies to cat albumin that cross-react with pork albumin (pork-cat syndrome).^{795,1093} Secondly, an enigmatic allergic reaction to the monoclonal antibody cetuximab led to the recognition that a surprisingly large number of individuals in the South East of the United States had IgE antibodies to the disaccharide galactose alpha-1, 3-galactose (alpha-gal).¹⁰⁹⁴ This oligosaccharide is a blood group substance of the nonprimate mammals and is present on all forms of tissue including red meat,^{1095,1634} organs such as kidney,^{1096,1633} gelatin,¹⁰⁹⁷ and cat

TABLE 45 Allergens available for diagnosis for different forms of mammalian meat allergy

Clinical syndrome	Allergens involved	Available allergen components
Pork-cat syndrome	serum albumins	Fel d 2, Can f 3, Sus s 1, Bos d 6
Alpha-gal syndrome (AGS)	alpha-gal	alpha-gal
Meat allergy related to milk	milk allergens	Bos d 4-6, Bos d 8
Primary meat allergy	meat allergens	Bos d 6, Sus s 1

TABLE 46 Routes of sensitization for allergens related to allergic reactions to meat

Inhaled:	Cat albumins related to systemic reactions to pork
Oral:	Cow's milk allergens related to anaphylactic reactions to beef
Skin:	Tick bites leading to alpha-gal sensitisation

IgA¹⁰⁹⁸ but also in some drugs (e.g., cetuximab, anti-venom, pancreatic enzymes, gelatin-based plasma expanders) and gelatin containing vaccines (e.g., varicella, measles, mumps, rubella, Zostavax).¹⁰⁹⁹ For a detailed description of the alpha-gal epitope, please see chapter "The role of CCD." The term "alpha-gal syndrome" (AGS) is the preferred term to describe allergic reactions to mammalian meat, which are based on sIgE to alpha-gal.^{20,1100} I. AGS has been reported worldwide.¹¹⁰¹⁻¹¹⁰⁴

4 – Sensitization to individual molecules and their clinical relevance

Prior to the year 2000, it was generally assumed that sensitization to food antigens was induced by oral exposure. However, we now have at least two alternative routes of exposure (Table 46).

Sensitization to cat albumin occurs predominantly in patients who own cats and is assumed to occur by inhaling dander particles carrying this protein. Thus the route of sensitization to the cross-reacting pork albumin reflects a sensitization that was initially established by inhaled exposure. The second alternative route is through the skin. For the oligosaccharide alpha-gal, the only established route for sensitization is by tick bites, although sensitization by inhalation, e.g., animal dander, occupational allergens is conceivable. Different tick species that have been implicated: *Amblyomma americanum* in the USA; *Amblyomma sculptum* in Brazil, *Ixodes holocyclus* in Australia; *Ixodes ricinus* in Europe and *Haemaphysalis longicornis*, and *Amblyomma testudinarium* in Japan. The presence of alpha-gal in the gut and salivary glands of *I. ricinus* has been reported^{1105,1106} as well as alpha-gal-carrying proteins in saliva from the ticks *I. ricinus*, *A. sculptum*, *H. longicornis*, *Hyalomma marginatum*.^{1107,1108,1631,1632} Furthermore, the IgE-binding saliva proteins have shown to be vitellogenins.¹¹⁰⁸ There is good evidence that tick bites are necessary since children or adults raised in arctic areas, where ticks are not present, can eat meat carrying this oligosaccharide without inducing IgE-mediated sensitization to alpha-gal.¹¹⁰⁹ However, it is possible that also other ecto-parasites such as "chiggers" could be relevant.¹¹¹⁰

AGS has several novel features that are relevant to diagnosis and management.²⁰ The onset is in the majority of cases in adult life after eating meat without problems for many years, the reactions start 2-6 hours after mammalian meat consumption, the patients have IgE against alpha-gal and nearly all report to have been tick bitten.^{975,1096,1111,1112} The majority of the patients suffer from urticaria and/or gastrointestinal symptoms. The most severe form of allergic reactions, anaphylaxis, is common. Furthermore, atopy has been shown to increase the risk of anaphylaxis.¹¹¹⁴ Some patients may tolerate red meat at some occasions but have severe reactions on others. This could be due to cofactors such as exercise, nonsteroidal anti-inflammatory medications, and alcohol that may modify the allergic response.¹⁰⁹⁶ In addition, the reaction is dependent on the concentration of alpha-gal in the meal: It is highest in innards like kidney when compared to muscle meat.¹¹¹³ The presence of alpha-gal in furry animal extracts has revealed the need of molecular allergen diagnosis to successfully identified AGS patients who are primarily sensitized to, e.g., cat, dog or horse.¹¹¹⁴

As the alpha-gal epitope is structurally related to blood group B, patients belonging to this blood group have been shown to have a reduced risk of developing the disease due to self-tolerance to the B-antigen.^{1112,1115} Beyond allergy, Dr. Platts-Mills and colleagues have reported that alpha-Gal sensitization could be a risk factor for coronary artery disease. They noted that there was significantly worse coronary artery disease in patients who had IgE to alpha-gal.¹¹¹⁶

5 – Clinical management

The diagnosis is based on (i) history, (ii) skin test and/or IgE antibody assays, and (iii) challenge protocols (Figure 98).

The main parts of management are accurate diagnosis and education. The only effective form of treatment for allergic reactions to meat is to avoid the relevant source or sources. As AGS also plays a role in occupational settings, this may require a change of profession, i.e., if cooks are affected.¹¹¹⁷ Discussion of avoidance may require written protocols, as well as discussion of the many forms in which proteins derived from meat are eaten. With meat sensitization in childhood it may be necessary to go dairy-free to establish a symptom-free condition. After that it should be possible to carry out challenge tests if necessary and to progressively modify details of the diet. For pork-cat syndrome, it is usually sufficient to avoid pork and pork products. In some cases, the cross-reactivity with beef albumin is strong enough to give symptoms with beef products. As albumins are thermolabile proteins, well-cooked meat is often tolerated whereas ham and sausage are not. Challenges may be useful to assess the tolerance of well cooked beef in children.

The diagnosis of alpha-gal sensitivity may be obvious from the history, skin tests or IgE analyses. However, it may be useful to have a panel of serum IgE assays to establish the diagnosis of meat reactions. This will need to include IgE to alpha-gal, beef, and pork, as well as IgE antibodies to milk, cat and cat albumin. Chicken, turkey and cod can be used as negative controls. If the IgE antibody concentration to alpha-gal is greater than or equal to 2 kU/L or more than 2% of the total IgE, this makes the diagnosis very likely. Furthermore, if the patient responds clinically to a diet avoiding red meat, this is a good criterion for diagnosis.²⁰

Full avoidance of all products containing alpha-gal is not easy because this includes all products derived from mammals including dairy.¹¹¹⁸ However, most cases require a significant dose of red meat (i.e., ≥ 20 g of meat) to cause reactions, and over 80% of cases can tolerate milk and milk products. In many cases, the patients have already recognized what they can tolerate before they present to physicians. As in other IgE-mediated food allergies, mastocytosis increases the risk for severe reactions also for alpha-gal allergic individuals. Thus, measurement of serum tryptase in the investigation of red meat allergy is recommended. Drugs of porcine origin such as pancrelipase and Enzynorm f contain alpha-gal and should be administered with caution in affected patients.¹¹¹⁹ Oral challenge tests may be necessary in patients where the diagnosis remains unclear or who do not always show reactions in response to red meat exposure. In the latter, cofactors may need to be included to elucidate clinically overt reactions. In these cases, patient management may also include the advise to regularly consume small amounts of meat that were tolerated in the absence of augmentation or cofactors to allow maintenance of tolerance.

Moreover, patients should be informed that further tick bites can maintain or lead to increases in the concentration of alpha-gal IgE.^{1120,1121} Appropriate avoidance, e.g., clothing and sprays should be recommended. Cofactors (for example, alcohol, ASS, physical exercise) can increase intestinal absorption and substitute for higher sensitivity to red meat.¹⁰⁹⁶

There are no consistent studies using immunotherapy for meat allergy, nor are there studies using anti-IgE as therapy.

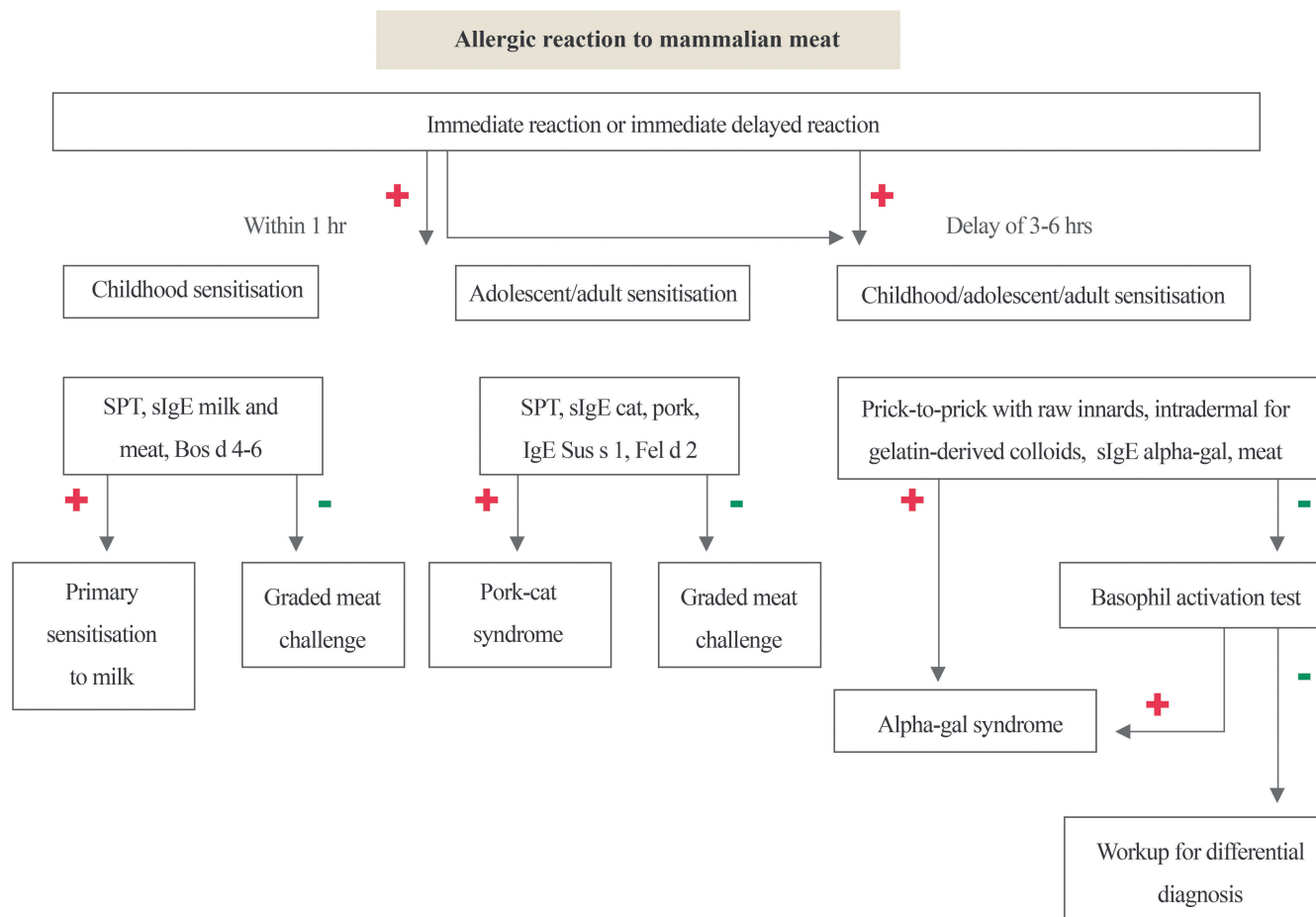


FIGURE 98 Diagnostic algorithm in patients with allergic reactions to meat

6 - Clinical cases

Case 1 (original)

History: Patient, 56-year-old female, who visited the emergency room (ER) in early autumn due to urticaria. She had eaten a sausage five hours earlier. Two months later she once more visited the ER due to an anaphylactic reaction six hours after eating a hamburger. She had during the summer obtained several tick bites and had noted prolonged redness and itching at the site of the tick bite.

In vitro testing: IgE against alpha-gal 80 kU/L, beef 14 kU/L, pork 7.6 kU/L and milk 1.7 kU/L.

Diagnosis: Red meat allergy.

Recommendation: She became symptom-free after avoiding red meat.

Case 2 (original)

Clinical history: An 18-year-old male patient described five, mostly nocturnal, anaphylactic reactions with hives, nausea, abdominal pain, and dyspnea in the last ten years with unknown trigger. In four of five episodes, allergic reactions occurred 3–5 h after a meal containing pork meat, once with physical exercise (cycling) where cutaneous reactions occurred shortly (1 h) after. The patient was otherwise healthy and had no history of atopy or other (food) allergies.

No further episodes occurred as the patient had become a vegetarian. There was a history of tick bites in the patient's childhood.

In vitro testing: Specific IgE to alpha-gal was highly positive (29.6 kU/L) and negative to pork (<0.1 kU/L), beef (<0.1 kU/L), chicken (<0.1 kU/L) and omega-5 gliadin (<0.1 kU/L). The tryptase level was 2.13 µg/L (<11.4 µg/L).

in vivo testing: Skin prick test was negative to beef, lamb, pork, and cow's milk, but prick-to-prick test revealed positive reactions to raw and cooked pork kidney. Intradermal testing was positive to the gelatin colloid plasma expander Gelafundin® 4% (gelatin polysuccinate) diluted 1:100.

Food challenge: An oral challenge was performed with cooked pork kidney (17 g) under careful monitoring. The patient developed urticaria approx. 3 h after challenge and was treated with antihistamines and corticosteroids.

Diagnosis: Late-onset anaphylaxis to red meat based on IgE recognizing alpha-gal.

Recommendation: The patient was informed to avoid red meat especially in combination with cofactors such as alcohol, acetylsalicylic acid or exercise as well as oral ingestion of large amounts of gelatin. Furthermore, an allergy pass listing Cetuximab and gelatin colloid plasma expander Gelafundin® was handed out.

It should be emphasized that skin prick test responses to beef, lamb, pork, and cow's milk can be very small in size or negative. In adults, intradermal skin tests may give much clearer results (Figure 98).

Case 3 (original)

Clinical history: A 34-year-old female presented to the clinic with repeated episodes of oral itching, with or without systemic urticaria following eating pork. She had a long history of cat and dog exposure and was known to be clinically allergic to cats.

In vitro testing: Serum results showed IgE to cat 34 kU/L, pork 13.5 kU/L, cat albumin (Fel d 2) 95 kU/L and alpha-gal <0.35 kU/L. Absorption studies showed 90% reduction with cat albumin, 70% with dog albumin and 10% with pork albumin.

Diagnosis: The implication is that her primary sensitization was to cat albumin and the symptoms after eating pork were due to cross-reactivity between the albumins. She responded fully to a diet avoiding pork.

7 – Research and future perspectives

As the tick population is increasing, mammalian meat allergy will become more common. This underlines that more knowledge regarding the disease is needed, e.g., which are the mechanisms of the delayed

reactions. From a clinical perspective biomarker/s that can identify early symptomatology that over time develops in severe allergic reactions, anaphylaxis, are warranted. Moreover, as only certain individuals develop anti-alpha-gal IgE there are possible other contributing factors, adjuvants, which need to be identified in tick saliva.

Textbox

- IgE to pork and cat albumin are markers of pork-cat syndrome
- IgE to alpha-gal is a marker of mammalian meat allergy (AGS)
- Patients with alpha-gal syndrome (AGS) should avoid tick bites

B15 – Fruit and vegetable allergy

Barbara Ballmer-Weber, Karin Hoffmann-Sommergruber

Highlights

- Allergies to fruits and vegetables can either be due to cross-sensitization with pollen allergens or are due to “true” food allergens
- The majority of plant food allergens can be assigned to a restricted number of protein families
- Frequently observed IgE cross-reactivity does not always coincide with clinical relevance
- Prick to prick testing using raw plant food is often superior to extract based testing
- Food challenges are the method of choice to rule out clinically silent IgE cross-reactivity

1 – The allergen sources

Plant foods, especially fruits and vegetables are part of a healthy diet and their consumption is recommended for prevention of cardiovascular and metabolic disorders. However, in predisposed individuals, food allergic reactions are caused/induced upon uptake of a range of fruits and vegetables.

Fruits

While the range of allergenic fruits is broad, the majority of frequent inducers of allergic reactions belong to the *Rosaceae* family. Therefore, this botanical family will be described in more detail. Among those, pyrenocarps (e.g., apple, pear) and stone fruits (e.g., peach) but also nuts (almond) are able to induce food allergic symptoms in atopic patients.

Fruits are consumed raw or processed, and peel, pulp and seeds contain allergens. For example, the nonspecific lipid transfer proteins (nsLTPs) are accumulated in the outer layer of fruits, and by removing the peel, the allergen exposure can be reduced. Also, certain apple cultivars are known to have low allergen content for the Pathogenesis-related 10 (PR-10) proteins such as Santana and Elise and nsLTPs such as Santana and Ecolette, while others are expressing higher amounts of these allergens such as Golden Delicious (high Bet v 1 and LTP content).^{1122,1123} Unfortunately, the reduced levels of Mal d 1 do not always coincide with low levels of Mal d 3, thus an overall hypoallergenic apple is so far not available. Also postharvest treatment processes may have impact on allergen levels, as storage under defined conditions has suggested for Mal d 1 and Mal d 3 levels.¹¹²⁴ Furthermore, fruits can be eaten in cakes, desserts, jams and jellies, as ingredients of dishes and as fruit juices either after pasteurization or without heat treatment, also mere cutting an apple into pieces may result in an improved tolerance due to oxidative degradation of Mal d 1. In “biological cosmetics” fruit extracts are also used and may pose an unexpected risk in highly sensitized patients.

In this chapter kiwifruit has been chosen as an example of a “novel food,” entering the European market in the late 70 s of the 20th century, and thus eventually developing into a relevant allergen source, previously not anticipated as such. Furthermore, citrus fruits, banana, melon, and grapes represent plant food allergen sources, affecting mostly Southern European patients/consumers. The well-known latex fruit syndrome, comprising allergic reactions against latex products and fruits and vegetables containing cross-reactive allergens will only be briefly mentioned in this chapter, more detailed information is provided in chapter B22.

Vegetables

Also vegetables represent a relevant source of allergens, with celery being an allergenic food to be labeled on food products according to the EU allergen legislation (European Directive 2007/68/EC). Celery and carrot, both belonging to the botanical Apiaceae family can be consumed raw as well as cooked, and several studies have investigated the impact on heat treatment on individual allergens, thus up- or downregulating their allergenic capacity. Especially in celery, the bulb (tuber; celeriac), and the green parts (stalks) are eaten raw as well as cooked. In addition, celery seeds can be used as a spice as well and are offered either as “celery salt” alone or as an ingredient in spice mixtures to be used for various dishes. In the latter case the presence of celery derived proteins may not be that evident and may lead to unexpected reactions in predisposed individuals. Also celery seed oil is sometimes used as a food ingredient or in cosmetics. In addition to celery and carrot, tomato and bell pepper are well known allergenic foods. In the recent past, additional tomato allergens belonging to the seed storage proteins have been identified from the seeds of the tomato fruit.

Finally a brief overview on Cannabis allergy is provided, reflecting the increasing number of allergic cases upon Cannabis exposure.

2 – Major and relevant minor allergenic molecules

Fruits

Within the *Rosaceae* PR-10 protein family allergenic members are known from apple, peach, apricot, pear, raspberry, and strawberry. These proteins are major allergens for instance in apple and peach, and are located in the pulp and skin of the fruits. In general, PR-10 proteins are labile proteins at extreme pH conditions and their structure is affected upon heat treatment and endogenous inhibitors such as polyphenols.¹¹²⁶ They are constitutively expressed in plant tissues. In addition, they are upregulated upon environmental stress and pathogen attack. They are supposed to act as plant steroid carriers. PR-10 proteins in fruits are supposed to induce mild local reactions in patients. Also heat treatment of fruits (e.g., pasteurized fruit juices and jams) affects PR-10 allergenicity (see also further information on allergenic PR10-proteins in chapter C02). Nonspecific lipid transfer proteins (nsLTPs) are small proteins with a rigid tertiary structure formed by 4 disulfide bridges. Their function is to transport lipids across cell membranes. For example, allergens from this protein family are identified from

Rosaceae fruits (apple, peach, apricot, cherry, plum, pear, raspberry, strawberry, and mulberry),³⁵ citrus fruits, kiwifruit, banana, and grape. They are major allergens and primarily located in the outer tissue layers (peel) of fruits. Upon pathogen attack they are upregulated and therefore classified as PR-14. In contrast to PR-10 allergens, they are stable proteins not affected by low pH environment and heat treatment. However, at neutral pH their resistance to heat treatment is much lower as compared at acidic pH.¹¹²⁷ In general, severe, generalized allergic symptoms are correlated with nsLTPs' intake. An inverse relationship between severity of LTP induced symptoms in peach and co-sensitization to profilin and Bet v 1 has been reported.^{1128,1129} Further information on allergenic nsLTPs is provided in chapter C03.

Profilins are small proteins with an ubiquitous expression throughout the plant kingdom. They are functional in various important cell-signaling pathways and bind actin. These small proteins are of intermediate to low stability when subjected to heat treatment. sensitization to profilin is frequently observed in patients; however, it often lacks clinical relevance. Allergens from the profilin family have been identified in *Rosaceae* fruits (e.g., apple, peach, pear, strawberry), citrus fruits (sweet orange, litchi), banana, kiwifruit, and melon. Further information on allergenic profilins is provided in chapter C01.

Thaumatococin-like proteins share a common 3 dimensional rigid structure defined by conserved cysteine residues forming 8 disulfide bridges. These proteins are expressed in ripening fruits and are upregulated upon biotic and abiotic stress (PR-5). They are regarded as minor allergens, based on data obtained from apple, peach, cherry, green kiwifruit, and banana.

The gibberellin-regulated protein (GRP), peamaclein, was identified from peach. This small protein is upregulated upon biotic stress and located in the peach peel.⁵⁵⁹ Later on, GRPs have been described in other fruits such as apricot, pomegranate, orange, and cherry^{591,1130} (see also chapter C09).

In pear another allergen, an isoflavone reductase related protein was identified, which showed allergenic activity in a small group of patients allergic to pear.¹¹³¹

The green kiwifruit contains PR-10, nsLTP, profilin, and thaumatococin-like proteins with allergenic activity. The cysteine protease, actinidin, enzymatically degrades seed storage proteins and is upregulated in blossoms and fruits. In kiwifruit monosensitized allergic patients it is a major allergen. In addition, a number of minor allergens have been identified such as phytocystatin, kiwellin, pectin-methylesterase and its inhibitor and a major latex-protein, which belongs to the Bet v 1 superfamily. 2S albumins and 11S globulins localized in the seeds were also characterized as allergens.¹¹³²

While actinidin is abundantly expressed in green kiwifruits, its expression level and allergenic activity is much lower in golden kiwifruits¹¹³³ and in certain kiwifruit cultivars.¹¹³⁴

Banana contains profilin, nsLTP and thaumatococin-like proteins with allergenic activity. In addition, beta-1,3 glucanase (PR-2) and class I chitinase (PR-3), both degrading fungal cell walls and the exoskeleton of insects, are banana allergens and contribute to the

cross-reactivity with latex allergens. In pomegranate, a class III chitinase has been described. From citrus fruits nsLTPs type 1 were identified, germin-like proteins, and gibberellin-regulated proteins as relevant allergens. In contrast to other fruits, profilins are regarded as major allergens with clinical relevance in citrus fruits.¹¹³⁵

From melon profilin,¹¹³⁶ cucumisin, an alkaline serine protease,¹¹³⁷ and a member of the PR-1 family are identified as allergens.¹¹³⁸

Papaya contains an allergenic endopolygalacturonase, Cari p 1¹¹³⁹ and a cysteine protease, Cari p 2,¹¹⁴⁰ (Figures 99 and 100, and Table 47).

Vegetable

In celery, the PR-10 protein is a major allergen, especially in Central Europe. Also, profilin is supposed to sensitize a relevant number of celeriac allergic patients. Less frequently, sensitization to the FAD-containing oxidase, a glycoprotein, is observed. In this case, the carbohydrate moieties of this enzyme seem to be relevant for the IgE-binding capacity.¹¹⁴¹ In the recent past, nsLTPs have been identified from celery. While the nsLTP type 1 is expressed in the stalks, the nsLTP type 2 is found in the tuber.^{1142,1143} Only limited IgE-cross-reactivity is observed between those two different proteins. Recently a new celery allergen, Api g 7, a defensin like protein 1, was detected in celery tuber.¹¹⁴⁴ Similarly to celery, the PR-10 protein is a major allergen in carrot. At least 2 isoforms of Dau c 1 seem to be responsible for sensitization and provide only partial cross-reactivity. In addition, profilin has been identified as a minor allergen.

Finally, the isoflavone-reductase-like protein is the most recently characterized food allergen. However, neither data on the prevalence of sensitization are available nor the clinical relevance of this allergen is known to date. From tomato, profilin was identified as a minor allergen. Additionally, beta-fructofuranosidase and cyclophilin and a PR-10 protein, are minor allergens. Recently nsLTPs, both, type 1 and type 2 were characterized; however, little is known about their prevalence in sensitization. For bell pepper, a gibberellin-regulated protein, profilin and the thaumatococin-like protein—called osmotin-like protein—have been identified as allergens. However, data about their relevance for diagnosis are rather limited.

A class I chitinase was identified from avocado. Finally from potato, several allergens were identified including patatin, cathepsin D inhibitor, cysteine protease inhibitor, and a serine protease inhibitor (Figures 99 and 101; Table 48).

3 – Sensitization to individual molecules and their clinical relevance

Epidemiology and sensitization/cross-reactivity rates

Prevalence data for plant food allergies are scarce, and the available data so far originate from a few studies. In a systematic review by Zuidmeer et al. the overall prevalence for fruits ranged from 0.1 to 4.3%.¹¹⁴⁵ Within a European Community Respiratory

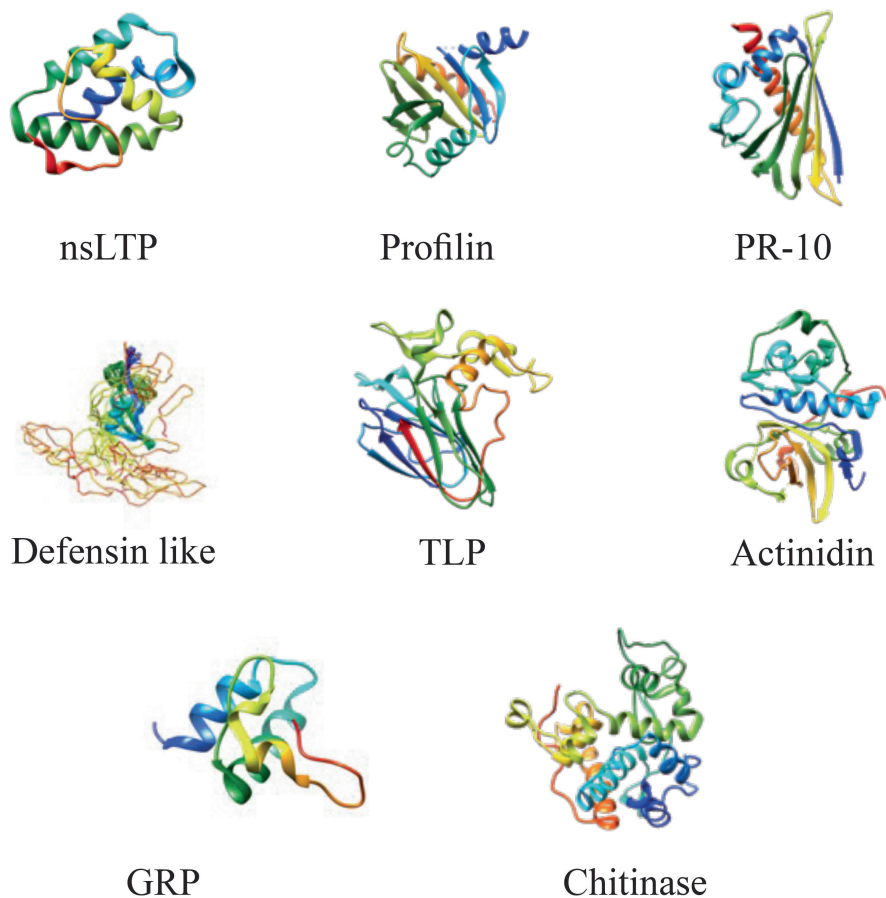


FIGURE 99 Molecular structures of well-known food allergen protein families. ID numbers of the crystal structures accessible in the PDB databank <https://www.rcsb.org>: Non specific lipid transfer proteins (nsLTP from peach, Pru p 3; PDB:2B5S); Profilin (birch pollen; Bet v 2; PDB:1CQA); PR-10 proteins (celeriaceae, Api g 1; PDB:2BK0); Defensin like proteins (mugwort, Art v 1; PDB:2KPY); Thaumatin-like proteins (TLP from cherry, Pru av 2; PDB:2AHN); Actinidin (from kiwifruit; *A. arguta*; PDB:3P5X); Gibberellin-regulated protein (GRP; potato; snakin like; PDB:5E5Y); Chitinase (from papaya; PDB:3CQL)

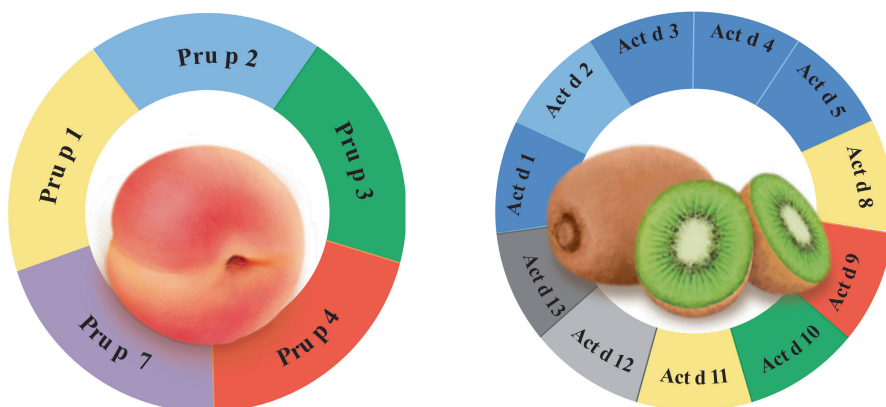


FIGURE 100 Peach and kiwifruit as selected examples of fruit allergen sources. Proteins belonging to the PR-10 family are depicted in yellow, TLPs in light blue, nsLTPs in green; profilins in red; GRP in light lilac; seed storage proteins (2S albumins and cupins in grey); kiwifruit specific allergens: Act d 1, Act 3-Act d 5 in dark blue

Health Survey (ECRHS) overall sensitization rates for fruits were assessed by Burney and colleagues in 2010 and 2014. Peach was the most frequent inducer of sensitization increasing from 5.4% to 7.9% in 2014. Apple ranked second with a sensitization rate of 4.2% and 6.5% followed by kiwifruit with 3.6% and 5.2% sensitizing capacity.^{1146, 1151} Prevalence data on allergen-specific sensitization have been generated by a few Europe-wide studies. For apple the SAFE study provided data on Mal d 1-Mal d 4,³⁶ while the peach allergens were investigated in Spanish and Italian studies.^{999,1129,1148} reflecting the clear cut difference in the frequency of LTP-sensitization predominant in the Southern European areas as compared to the PR-10 sensitization detected in areas with Fagales pollen exposure. Several

kiwifruit studies were performed including a multicenter, within the EuroPrevall project and single center studies.^{1149,1150}

Vegetables

In the systematic review the overall prevalence of food allergies caused by vegetables is around 1.4%.¹¹⁴⁵ The sensitization rates for vegetables were assessed by Burney et al. within the ECRHS study. Sensitization to carrot was determined as 3.6% and increased in 2014 to 5.0%, while celeriac sensitization was observed in 3.5% and 6.3% of the general population, respectively.^{1146,1151} In celeriac allergy, allergen-specific sensitization prevalence was investigated within the EuroPrevall project.¹¹⁵² For carrot allergy one study investigated the sensitization rate in Switzerland, Denmark and Spain.¹¹⁵²

TABLE 47 Allergens in Fruits (source: IUIS Allergen Database, Dec 2021; www.allergen.org). Molecular weight and IgE-prevalences are listed according to WHO/IUIS Allergen Nomenclature Sub-Committee Website (www.allergen.org), unless otherwise referenced.

Allergen source	Allergen	Biochemical name	MW (kDa)	IgE prevalence/ Sensitisation
<i>ROSALES</i>				
Apple (<i>Malus domestica</i>)	Mal d 1	Pathogenesis related protein 10 (PR-10)	17	15-70% of apple allergic patients ³⁶
	Mal d 2	Thaumatococin-like protein (TLP)	23	5-18% of apple allergic patients ³⁶
	Mal d 3	Non specific lipid transfer protein (nsLTP type 1)	9	1-50% of apple allergic patients ³⁶
	Mal d 4	Profilin	14	10-40% of apple allergic patients ³⁶
Peach (<i>Prunus persica</i>)	Pru p 1	Pathogenesis related protein 10 (PR-10)	17	11% of peach allergic pediatric cohort ¹¹⁴⁷ ; 7-13% in adults (Spain, IT) ^{1129, 1148}
	Pru p 2	TLP	23	Not available
	Pru p 3	nsLTP	9	96% of peach allergic children ¹¹⁴⁷
	Pru p 4	Profilin	14	10% peach allergic children (Spain), 7-34% adults (Spain, IT) ^{1147, 1148}
	Pru p 7	Gibberellin regulated protein (GRP)	7	62-65% peach allergic adults (FR, PN) ^{231, 1130}
<i>ERICALES</i>				
Green Kiwifruit (<i>Actinidia deliciosa</i>)	Act d 1	Actinidin	30	5-32% (Central Europe – Iceland) ¹¹⁴⁹
	Act d 2	TLP	23	2-18 % ¹⁷⁰⁷
	Act d 3	glycoprotein	40	Not available
	Act d 4	Phytocystatin	11	Not available
	Act d 5	Kiwifelin	28	2-18 % ^{1148, 1707}
	Act d 6	Pectin methylesterase inhibitor	18	Not available
	Act d 7	Pectin methylesterase	50	Not available
	Act d 8	PR-10	17	7-58% ^{1163, 1707}
	Act d 9	Profilin	14	7-31 % ¹⁷⁰⁷
	Act d 10	nsLTP type 1	10	3-2% ¹¹⁴⁹
	Act d 11	Major latex protein/ripening-related protein (MLP/RRP), Bet v 1 family member	17	24%
	Act d 12	Cupin, 11S globulin	50	71%
	Act d 13	2S albumin	11	18%
<i>SAPINDALES</i>				
Sweet orange (<i>Citrus sinensis</i>)	Cit s 1	Germin like protein	23	78% ¹⁶⁷⁴
	Cit s 2	Profilin	14	96% ¹⁶⁷⁴
	Cit s 3	nsLTP type 1	9	Not available
	Cit s 7	Gibberellin regulated protein (GRP)	7	86% ¹¹³⁰
<i>ZINGIBERALES</i>				
Banana (<i>Musa a - acuminata</i>)	Mus a 1	Profilin	14	44% (small cohort)
	Mus a 2	Class I chitinase	33	Only few cases reported
	Mus a 3	nsLTP type 1	9	20%
	Mus a 4	TLP	20	72%
	Mus a 5	Beta-1,3-glucanase	30	74-84% in a pediatric cohort
	Mus a 6	Ascorbate peroxidase	27	Only few cases reported
<i>CUCURBITALES</i>				
Melon (<i>Cucumis melo</i>)	Cuc m 1	Alkaline serine protease (cucumisin)	67	Not available
	Cuc m 2	Profilin	14	Only few cases reported
	Cuc m 3	Pathogenesis-related protein PR-1	17	Only few cases reported



FIGURE 101 Celery and tomato as selected examples of vegetable allergen sources. Proteins belonging to the PR-10 family are depicted in yellow, nsLTPs in green (type 1 in light green and type 2 in dark green); profilins in red; cyclophilin and defensin like protein in light grey FAD oxidase and beta-fructofuranosidase in dark grey

4 – Clinical relevance, diagnosis, and management

Although a number of well characterized components are available to facilitate the *in vitro* diagnosis in fruit and vegetable allergies, some important ones are still lacking¹¹⁵⁴ (the components offered for allergen specific *in vitro* diagnosis are indicated in the Appendix). To date the following proteins are used for CRD: cross-reactive allergens derived from inhalant allergenic sources (Bet v 1 and Bet v 2 from birch pollen and the latex allergens Hev b 6.01, 6.02, and 11) as well as food components from Rosaceae fruits (Mal d 1,2,3,4; Pru av 1,3,4; Pru p 1,3,4,7; Fra a 1,3),^{36,99,1148,1155} kiwifruit allergens (Act d 1,2,5,8,10; Act d 11), Apiaceae allergens (Dau c 1, Api g 1,2,6) and some tomato (Sola l 6) and potato (Sola t 1) allergens. Therefore, the following section focuses on Rosaceae, Apiaceae, kiwifruit allergy and the latex-fruit-syndrome.

Clinical relevance and clinical pattern

Rosaceae fruit allergy (Figure 102)

The Rosaceae family includes many edible fruits. Apple, cherry and peach are the best-studied species from an allergy point of view. Allergen components are available to date just from peach and apple. The allergens identified in the fruits of the Rosaceae family are 1) PR-10 (Bet v 1 family member, 2) profilin, 3) nsLTP type 1, 4) gibberellin-regulated protein and 5) thaumatin like protein. Due to high cross-reactivity between the PR-10 proteins, the profilins and the nsLTPs, the corresponding allergens derived from peach are usually applied for diagnostic approaches in all types of Rosaceae fruit allergies.

The Sensitization pattern to these allergens is geographically influenced. sensitization rates to the Bet v 1 homologous proteins are significantly higher in countries with high pollen exposure of the Fagales trees (birch, alder, hazel; see chapters B01 and C02), whereas sensitization to nsLTP is significantly higher in Mediterranean countries (see chapter C03).^{36,1146,1156} sensitization to Rosaceae fruit profilins (chapter C01) is more evenly distributed but most likely higher in the Mediterranean area.³⁶ sensitization to gibberellin-regulated protein has been described in Southern France and correlated with exposure to cypress pollen.^{231,1157}

Data on sensitization to thaumatin-like proteins in fruits are limited. Bet v 1-(PR-10) related food proteins, profilin and nsLTP are pan-allergens, depicting a high cross-reactivity across the plant kingdom and sensitization to these molecules is often not accompanied

by clinical symptoms.^{1158,1159} Therefore, determination of sIgE to these molecules should not be used as a screening tool (no prophetic testing!) and sensitization without convincing case history should always be validated by food challenge. All three protein families have been associated with the various types of clinical manifestations in Rosaceae fruit allergies ranging from contact urticaria of the oral mucosa (so called Oral Allergy Syndrome, OAS) up to anaphylaxis. The prevalence of systemic reactions in those patients with a confirmed fruit allergy is higher in nsLTP-mediated fruit allergies than in the Bet v 1 or profilin-mediated ones.^{34,36,1156} In the following, three typical patterns of Rosaceae fruit allergy are outlined.

- A** Patient with a sensitization to Fagales tree pollen and IgE to Bet v 1 may develop cross-sensitization to Bet v 1 homologous proteins from different *Rosaceae* fruits. Symptoms are elicited by unprocessed fruits. The usual manifestations are local oropharyngeal symptoms (OAS). *Caveat: in selected cases Bet v 1 (PR-10) related fruit allergy can be associated with systemic reaction,¹¹⁶⁰ i.e., in conjunction with co-factors (alcohol, exercise, NSAID intake, ingestion on an empty stomach¹¹⁶² or high quantity of the ingested Bet v 1 homologues).*
- B** Patient with a sensitization to nsLTP mainly derived from peach (Pru p 3) may develop cross-sensitization to other fruit nsLTPs. The clinical manifestations vary from local oropharyngeal symptoms up to anaphylaxis. The clinical pattern is influenced by co-factors (see under A), so called LTP syndrome.¹¹⁵⁷ Symptoms are elicited by unprocessed and processed fruits.
- C** Patients with a sensitization to profilin, frequently acquired via sensitization to grass pollen, might develop a cross-sensitization to profilin in *Rosaceae* fruits.³⁶ Sensitization to profilin is highly likely to be clinically silent but can elicit in a minor subset of patients local oropharyngeal symptoms (OAS). The risk for a systemic reaction is very low but has been described in patients with epithelial barrier damage of the oral mucosa in a Mediterranean area.³³⁹ *Caveat: sensitization to profilin is highly likely to be clinically asymptomatic.*

Kiwifruit allergy

Allergy to kiwifruit is one of the most frequently observed fruit allergies in Europe.¹¹⁴⁹ Thirteen kiwifruit allergens have

been identified to date (Table 47). An allergy to kiwifruit can be acquired via gastrointestinal tract (primary food allergy) or via cross-sensitization to birch or grass pollen and latex allergens. The allergic symptoms range from mild oropharyngeal symptoms to severe, generalized reactions. Actinidin, Act d 1, is the major allergen of kiwifruit and correlates significantly with a kiwifruit mono-sensitization.¹¹⁵⁰ Sensitization to Act d 8 and Act d 9 is specific for patients with pollen-kiwifruit allergies.^{1150,1163} The sequence homology between kiwifruit nsLTP (Act d 10) and other nsLTPs, particularly Pru p 3 from peach, is low and therefore there is a limited risk of cross-reactivity. Additionally, cross-reactivity between Hev b 11, a chitinase from latex, and a protein in kiwifruit has been identified. The sensitivity of IgE measurement to kiwifruit extract is low (17%) but could be increased by including different kiwifruit components (Act d 1–Act d 5 and Act d 8 Act d 9) to 77%.¹¹⁵⁰ Sensitization to Act d 1 was associated with the severity of the reaction¹¹⁴⁹ in a pan-European study and sensitizations to Act d 1 and Act d 3 were significantly correlated with anaphylactic reactions of patients from Spain.¹¹⁵⁵ In the following four typical patterns of kiwi allergy are outlined.

- A Patient with a sensitization to Fagales tree pollen and IgE to Bet v 1 may develop cross-sensitization to the Bet v 1 homologous protein Act d 8. The usual manifestations are local oropharyngeal symptoms (OAS).
- B Patient with a sensitization to profilin particularly from grass pollen may develop cross-sensitization to profilin in kiwifruit. The usual manifestations are local oropharyngeal symptoms (OAS).
- C Patient with a sensitization to latex proteins (i.e., Hev b 6 and 11) may develop cross-sensitization to homologous proteins in kiwifruit. The clinical pattern varies from mild oropharyngeal symptoms up to anaphylaxis.
- D Patients with a sensitization (usually monosensitization) to Act d 1 may develop a primary kiwifruit allergy. The risk to develop systemic reaction up to anaphylaxis is increased.

Apiaceae vegetable allergy

The major representatives of the Apiaceae family in terms of food allergy are celeriac (*Apium graveolens*) and carrot (*Daucus carota*). Celeriac allergy is highly associated with birch pollen and mugwort pollen sensitization referred to as birch-mugwort-celery-syndrome.

To date, 5 relevant celeriac allergens have been identified in celeriac tuber, Api g 1 (Bet v 1 homologue), Api g 2 (nsLTP type 1), Api g 4 (profilin), Api g 5 (flavoprotein) and Api g 7, the defensin like protein 1 (www.allergen.org). In addition Api g 6, an nsLTP type 2 protein was identified in celery stalk. The application of Api g 1, 4, 5 in component resolved diagnosis, increased the sensitivity from approximately 70% to 88% (75% rApi g 1, 42% rApi g 4 and 42% to nApi g 5).¹¹⁵² Celeriac-induced symptoms range from mild oropharyngeal symptoms (OAS) to anaphylaxis.¹¹⁶⁵ No marker allergen for prediction of severe reactions has yet been identified. Particularly severe reactions to celeriac occur in mugwort-sensitized patients.^{1152,1165} The culprit cross-reactive

allergens between mugwort and celeriac have not been identified so far. The clinical significance of the nsLTPs derived either from celeriac tuber (Api g 6) or from celery stalk (Api g 2) has not been confirmed to date.^{1143,1708}

Also carrot allergy is highly associated with a sensitization to birch and mugwort pollen.¹¹⁵³ Allergens identified in carrot are Dau c 1 (PR-10), Dau c 4 (profilin), Dau c 5 (isoflavone reductase), Dau c CyP (cyclophilin) and Dau c nsLTP. The diagnostic relevance of Dau c 5 and Dau c CyP has not been investigated and it is not clear whether Dau c nsLTP is indeed present in the edible parts of carrots. As for celeriac allergy, carrot allergy induced symptoms ranging from mild oropharyngeal symptoms (OAS) to anaphylaxis.¹¹⁵³ In the following two typical patterns of celeriac/carrot allergy are outlined.

- A Patient with a sensitization to Fagales tree pollen and IgE to Bet v 1 may develop cross-sensitization to Bet v 1 homologous proteins in Apiaceae vegetables such as carrot and celeriac. Symptoms are often elicited by unprocessed foods. The usual manifestations are local oropharyngeal symptoms (OAS).

Caveat: Bet v 1 (PR-10) related allergy to carrot and celeriac can be associated with systemic reaction. Systemic reactions are more frequently observed in PR-10-related celeriac and carrot allergy than in PR-10 related allergy to Rosaceae fruits¹¹⁶⁵ and might be elicited also by processed foods (particularly in celeriac allergy).¹¹⁶⁶

- B Patient with a sensitization to mugwort pollen may develop cross-sensitization to not yet defined allergens in celeriac and carrot. The clinical manifestation varies from local oropharyngeal symptoms up to anaphylaxis. Symptoms are elicited by unprocessed and processed vegetables. IgE determination and skin testing particularly to celeriac extract are often negative. Typical pattern: Sensitization to mugwort pollen, positive prick-prick test with native food, negative testing using celeriac extract.

Latex-fruit syndrome

In 30-70% of patients with latex associated food allergies have been observed, particularly to banana, avocado, chestnut, kiwifruit (see kiwifruit allergy), and many more.¹¹⁶⁵ Eleven percent of patients with a fruit allergy showed symptoms after latex challenge.¹¹⁶⁸ Oropharyngeal symptoms are frequently observed, but in about 10% of latex-associated food allergies, anaphylactic reactions have been observed. As cross-reactive allergens beta-1,3-glucanase (Hev b 2), hev-ein (Hev b 6.02) and the hev-ein-like domain of class I chitinases (Hev b 11) have been identified. However, further studies are needed since the pathogenic role of Hev b 6 and Hev b 11 have been questioned in a recent study.¹¹⁶⁹ Further information is provided in Chapter B22.

Cannabis-food syndrome

Cannabis sativa is a plant belonging to the Cannabaceae family. Hemp is a variety of *C sativa* grown for industrial use. The nsLTP Can s 3 is suspected to be the major cross-reacting allergen in the so called cannabis-food syndrome. In patients with cannabis-induced anaphylaxis, Can s 3 was the major allergen and 72% reported to suffer from a systemic food allergy, in part co-factor mediated.¹¹⁷⁰

TABLE 48 Allergens in Vegetables (source: IUIS Allergen Database, (www.allergen.org Dec 2021). Molecular weight and IgE-prevalences are listed according to WHO/IUIS Allergen Nomenclature Sub-Committee Website (www.allergen.org), unless otherwise referenced.

Allergen source	Allergen	Biochemical name	MW (kDa)	IgE prevalence/ Sensitisation
<i>APIALES</i>				
Celery (<i>Apium graveolens</i>)	Api g 1	Pathogenesis related protein 10 (PR-10)	16	75% ^{1152, 1165}
	Api g 2	nsLTP type 1	9	26%
	Api g 4	Profilin	14	42% BP risk factor; ^{1152, 1165}
	Api g 5	FAD-containing oxidase	58	45% ¹¹⁵²
	Api g 6	nsLTP type 2	7	38%
	Api g 7	Defensin like protein 1	12	50% ¹¹⁴⁴
Carrot (<i>Daucus carota</i>)	Dau c 1	Pathogenesis related protein 10 (PR-10)	16	58-100% ¹¹⁵³
	Dau c 4	Profilin	14	18% risk factor pollen profilin sensitisation ¹¹⁵³
	Dau c 5	Isoflavone reductase-like protein	33	6-20% ¹¹⁵³
<i>SOLANALES</i>				
Tomato (<i>Solanum lycopersicum</i>)	Sola l 1	Profilin	14	32%
	Sola l 2	Beta-fructofuranosidase	50	4/10 patients with CCD sensitisation
	Sola l 3	nsLTP type 1	9	Not available
	Sola l 4	Pathogenesis-related protein, PR-10, TSI-1	20	76%; Bet v 1 sensitisation risk factor
	Sola l 5	Cyclophilin	19	Not available
	Sola l 6	nsLTP type 2	7	71%
	Sola l 7	nsLTP type 1	13	71%
Potato (<i>Solanum tuberosum</i>) all data linked to potato	Sola t 1	Patatin	43	74% in a small pediatric cohort
	Sola t 2	Cathepsin D inhibitor PDI	21	51% in a small pediatric cohort
	Sola t 3	Cysteine protease inhibitor	21	58% in a small pediatric cohort
	Sola t 4	Serine protease inhibitor 7	16	67% in a small pediatric cohort
<i>LAURALES</i>				
Avocado (<i>Persea americana</i>)	Pers a 1	Chitinase class 1	32	75%
<i>ROSALES</i>				
Indian hemp (<i>Cannabis sativa</i>)	Can s 2	Profilin	14	16% (mixed exposure: airways and ingestion)
	Can s 3	nsLTP type 1	9	72%
	Can s 4	Oxygen evolving Enhancer Protein 2	27	No data published yet
	Can s 5	PR-10 homologue	18	78% (airway exposure –BP allergy risk factor)

However, further studies are needed. The content of the psychoactive component tetrahydrocannabinol (THC) is higher in **C sativa** than in hemp. Different parts of the plant can induce allergic reactions such as hemp seeds¹¹⁷¹ used in food industry or marijuana (dried flowering tops and leaves) and hashish (dried resin), both frequently consumed drugs.¹¹⁷² Furthermore, (occupational) allergy to Cannabis has been described reviewed in.¹¹⁷³ Cannabis allergy manifestations range from cutaneous contact urticaria to anaphylaxis. The allergens described so far in *C sativa* are Can s 3,¹¹⁷⁴ a nsLTP, Can s 5,¹¹⁷⁵ a Bet v 1 homologue, the cannabis profilin Can s 2 and Can s 4.¹¹⁷⁶ In a recent study, among 25 patients with immediate symptoms on

exposure to cannabis, 52% were sensitized to Can s 3, 80% to Can s 5 and 16% to Can s 2.¹¹⁷⁵ Only 7% of patients with a Cannabis allergy were sensitized to Can s 4 in another study.¹¹⁷⁶ The nsLTP, Can s 3, is suspected to be the major cross-reacting allergen in the so called cannabis-food syndrome. In patients with cannabis-induced anaphylaxis, Can s 3 was the major allergen and 72% reported to suffer from a systemic food allergy, in part co-factor mediated.¹¹⁷⁰

Clinical diagnosis of fruit and vegetable allergies

Allergies to fruits and vegetables are often initiated by a primary sensitization to pollen. Since the majority of fruit and vegetable allergens belong to a few protein families and are characterized by a

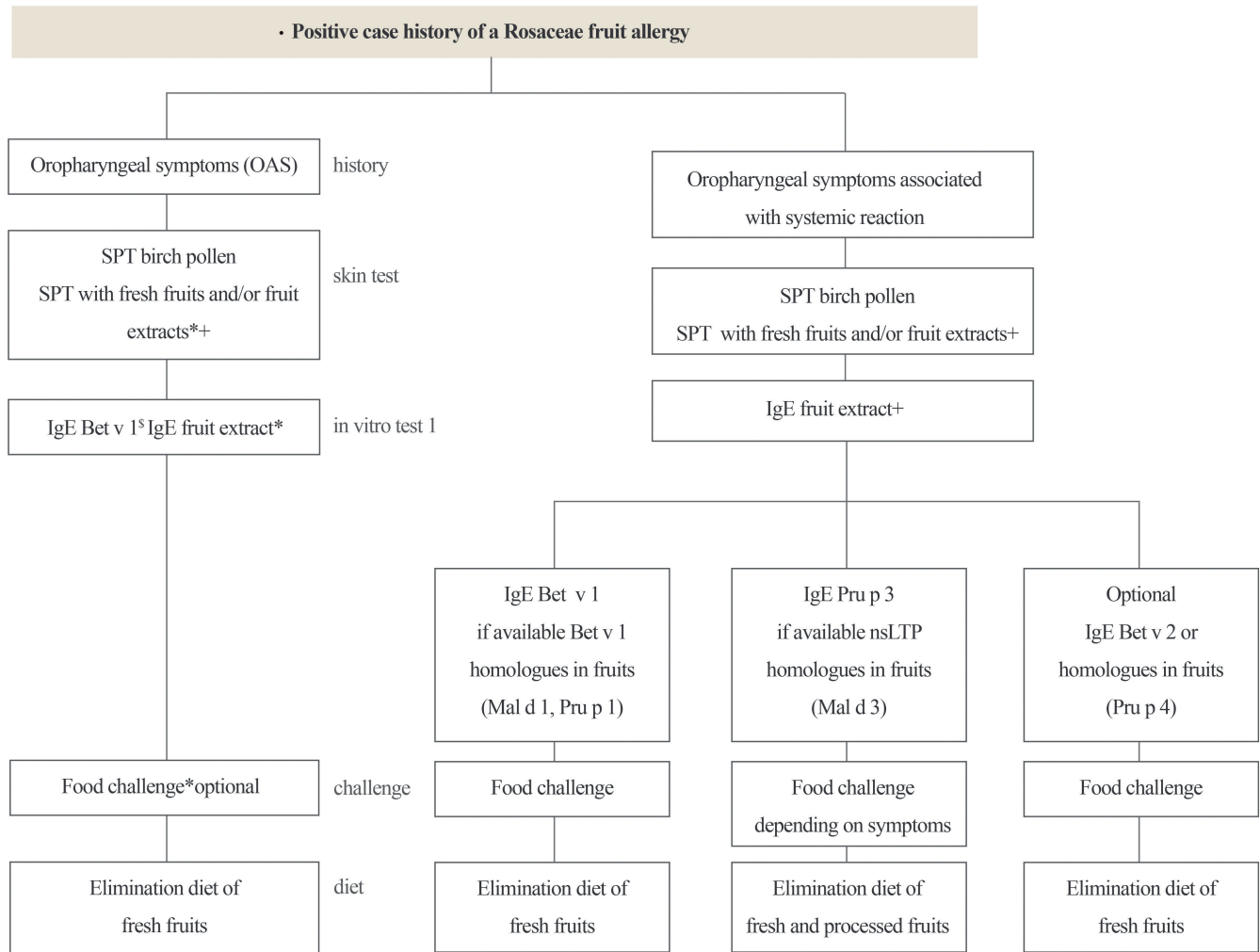


FIGURE 102 Diagnostic work-up in Rosaceae fruit allergy. * Patients with sensitization to birch pollen or other Fagales tree pollen and history of Rosaceae fruit induced oropharyngeal symptoms usually do not need further investigation; + Sensitivity of skin test or *in vitro* IgE determination using fruit extracts might be low due to underrepresentation of Bet v 1 homologues; \$ In patients from Mediterranean countries: OAS can also be linked to LTP or profilin sensitization. In case of LTP-mediated OAS, strict elimination of fresh and processed food is recommended.

high cross-reactivity, the clinical relevance of sensitization needs to be often established by food challenges.

IgE binding to cross-reactive carbohydrates (CCDs) is frequently found in sera from allergic patients and points to high cross-reactivity between inhalant (e.g., grass pollen allergies) and plant food allergies.⁶⁷ These glycan epitopes are also called “classical CCDs”—N-Glycans of the MMXF3, MMF3, and MUXF3-type.¹⁷ However, the clinical relevance of this IgE-based immune response is regarded as of low clinical relevance. Some multiplex assays either offer a specific testing for CCDs in parallel or even include a CCD blocking step before testing protein specific IgE recognition (more information on CCDs is provided in chapter A10).

Case history:

Allergies to pollen, latex, previous reaction(s) to the incriminated fruit/vegetable or fruits and vegetables from the same plant family.

Symptoms onset and course, elicitation by raw or processed food, co-factors (exercise, NSAID, alcohol etc.).

Skin prick test (SPT):

- commercial fruit and vegetable extracts limited due to false negative results as a consequence of under-representation of Bet v 1 homologous proteins and in part also nsLTPs
- prick-prick test with the offending nonprocessed fruits and vegetables has increased sensitivity but is limited by false positive results due to irritation of the skin.

Serum IgE testing:

- Due to the low stability of the Bet v 1 homologous proteins, these allergens are underrepresented (low sensitivity) in some but not all diagnostic food extracts, leading to false negative test results.

- IgE to Bet v 1 or Bet v 1 homologous proteins in reaction pattern A (Pru p 1, Mal d 1, Act d 8, Api g 1, Dau c 1) is indicative of a Bet v 1-related fruit/vegetable allergy but limited by low specificity.
- IgE to nsLTP (Pru p 3, Mal d 3) in reaction pattern B, might be associated with systemic reactions, limited by low specificity.
- IgE to Act d 1 is a risk factor for monosensitization and for systemic reactions to kiwifruit.
- IgE to Hev b 6.02 and Hev b 11 hint to possible latex induced fruit allergy.

Challenge tests:

- **A/C:** often not indicated if symptoms are limited to the oropharyngeal area, challenge with processed foods indicated in case of "unclear" history in terms of tolerance, i.e., in celeriac allergy.
- **B/D/E/F:** titrated challenge indicated in cases where allergy is not supported by clear-cut case history.

Clinical management

Recommendations

- **A/C:** Avoidance of symptom-eliciting raw fruits and raw vegetables; avoidance of processed foods only in patients with positive oral challenges with the respective processed food
- **B/D/E/F:** Avoidance of symptom-eliciting raw and processed fruits and vegetables, for celeriac allergy also traces.

Pharmacotherapy (emergency kit)

- **A/C:** Due to the small risk of systemic reactions or severe local reactions (angioedema lips, swelling oral mucosa) emergency medication for p.o. self-administration (antihistamines, eventually steroids).
- **B/D/E/F:** Emergency medication for p.o. self-administration (antihistamines, steroids), and in case of systemic reaction, epinephrine for self-administration (autoinjector).

Allergen-specific immunotherapy

Immunotherapy with birch pollen extract in Bet v 1-mediated fruit allergy showed contradictory results.^{1177,1178} Sublingual immunotherapy with rMal d 1 provided promising results for apple allergic patients in a first small trial.²²³ Recently a trial with Bet v 1-specific monoclonal antibody provided first positive results for birch pollen allergy, while data on BP-related food allergies are not available for this approach.¹¹⁷⁹

Oral tolerance induction using raw apples was observed in Bet v 1-related apple allergy,¹¹⁸⁰ but results need to be confirmed. Sublingual immunotherapy for patients with nsLTP-induced peach allergy using a Pru p 3 quantified peach extract has shown promising results.⁴⁰¹ In another study peach and peanut allergic patients were treated with the Pru p 3 enriched peach extract and showed reduced SPT reactivity and increased threshold levels in oral challenges for peach and also peanut in the peanut allergic group after 12 months of treatment.¹¹⁸¹

5 – Clinical cases

Case 1

History: 28 year old female patient, with recurrent anaphylactic reactions after unprocessed fruits. First anaphylaxis at the age of 4 years after ingestion of a plum, in the following after an apple, and at the age of 9 years after a peach.

Microarrayed specific IgE [ISU-E]:

Bet v 1 undetectable; Bet v 2 - 1.2; Ara h 9 - 2.9; Cor a 8 - 3.6; Jug r 3 - 8.8; Pru p 3 -12.0.

Diagnosis: LTP syndrome with recurrent anaphylactic reactions after plum, peach, apple

Recommendation: strict elimination of symptom inducing fruits in raw and processed form. Emergency kit with antihistamines, steroids and adrenaline pen. (SLIT with Pru p 3 quantified extract has been considered but denied by the patient).

Case 2

History: Male, 48 years old. Rhinoconjunctivitis to birch pollen and oropharyngeal itch to raw apples since school age. Regular ingestion of raw apples despite oral symptoms. He gets up in the night 3 am, ingests three apples on an empty stomach and develops oral itching, slight swelling of the lips and collapses. Two weeks later he gets up again in the night, ingests several apples on an empty stomach, develops severe itching of the oral mucosa, swelling of the lips and loses consciousness for few minutes. After 1 hour, recovers spontaneously.

In-vitro testing for specific IgE [kU/l]: Bet v 1: 88; Bet v 2 <0.35; Pru p 3 <0.35

SPT: Birch pollen extract, raw apple strongly positive

Oral food challenge: No symptoms with cooked apple puree, contact urticaria with blisters of the oral mucosa and slight angioedema of the lips after one quarter of a raw apple

Diagnosis: Anaphylactic reaction with oral contact urticaria, angioedema of lips and collapse after ingestion of large amount of raw apples on an empty stomach due to Bet v 1-related apple allergy.

Recommendations: Strict avoidance of raw apples; cooked apples without dietary restriction (due to thermal instability of Bet v 1-related allergens).

Case 3

History: 23 years-old female, no atopic background. Ingestion of kiwifruit, after 15 minutes nausea, abdominal cramps, emesis, diarrhea, drop of blood pressure. Emergency treatment.

SPT: negative to birch and grass pollen extract, latex, isolated positive skin test with raw kiwifruit.

In-vitro testing specific IgE [kU/l] (ImmunoCAP Specific IgE test): Bet v 1 <0.35; Bet v 2 <0.35; latex <0.35; kiwi extract <0.35.

Microarrayed specific IgE: positive to Act d 1 and Act d 2 Oral challenge: mucosa challenge with kiwifruit: oral contact urticaria, flushed face and nausea.

Diagnosis: primary kiwi allergy with sensitization to Act d 1 and Act d 2.

Recommendations: strict elimination diet for raw and processed kiwifruit, emergency kit with antihistamines, steroids and adrenaline pen.

B16 – Wheat and buckwheat allergies

Mika Mäkelä, Kati Palosuo

Wheat allergy

Highlights: Wheat allergy

- Wheat allergy can manifest as different clinical conditions including typical childhood food allergy, wheat-dependent, exercise-induced food allergy, and baker's allergy/asthma. The IgE response is diverse among patients and is directed against several allergens in all clinical conditions.
- Wheat is related to several clinically different allergic disorders in different organs including food allergy, wheat-dependent, exercise-induced anaphylaxis, respiratory allergy, and contact urticaria.
- Due to cross-reactivity with other allergens, including grasses, IgE measurement to whole wheat extract gives unreliable results with low specificity in diagnostics.
- There are several well-characterized allergenic molecules such as gliadins, glutenins, and alpha-amylase inhibitors, but it has been difficult to name single major allergens.
- Wheat sensitization is much more common than true clinical allergy.
- Sensitization to individual proteins is associated with disease manifestations but with significant overlap.

1 – The allergen sources

Wheat (*Triticum aestivum*) may be considered the most important source of food globally. For example, world trade in wheat is greater than for all other crops combined. Most food cultures serve wheat as an important part of daily meals, including bread, pasta, breakfast cereal, semolina, bulgur, and couscous, to name a few. Wheat has more vegetable protein than the other two worldwide important cereals, corn or rice. There are several different classifications of wheat and a number of different species and subspecies have been described, not to mention more than 25000 cultivars.¹¹⁸² However, there seem to be no clinically significant differences in allergenicity. In most countries, allergy to milk and egg are the two most common

food allergies, but wheat comes as third at least in Germany, Japan, and Finland.¹¹⁸³ Wheat allergy prevalence varies depending on the age and region from 0.4% to 4%.^{1183,1184} The most typical clinical manifestations of wheat-induced food allergy include IgE-mediated food allergy and celiac disease. The latter is a T-cell-mediated enteropathy induced by dietary gluten that shares features with organ-specific autoimmune disorders and it is not included in allergy treatment algorithms in most countries and is often treated by gastroenterologists rather than allergists. Therefore, celiac disease is not covered in this chapter other than in the classification as shown in [Figure 103](#).

2 – Allergen families

Wheat belongs to the Triticeae tribe of the grass family Poaceae together with rye and barley. Most allergenic proteins in wheat, including the cereal prolamins and bifunctional inhibitors (alpha-amylase/trypsin inhibitors), are members of the prolamin superfamily. The cereal prolamins (gliadins and glutenins) are seed storage proteins that are found in the grains of cereal grasses ([Figure 104](#)). Wheat prolamins share a great degree of sequence and structural homology with each other and with the corresponding proteins in rye and barley.³²²

3 – Allergenic molecules

The measurement of wheat-specific IgE and its use for clinical diagnosis is problematic due to the low specificity when using whole-wheat extract as a test allergen either in SPTs or in serum assays. Wheat-specific IgE is common among atopic children at all ages without true food allergies—up to 65% of the patients with grass pollen allergy had false-positive IgE-ab test results to wheat extracts.¹¹⁸⁵ On the other hand, some allergens are underrepresented in whole-wheat extract-based tests due to their relative insolubility ([Figure 105](#)).

The list of the World Health Organization/International Union of Immunological Societies Allergen Nomenclature Sub-Committee lists 28 wheat allergens (www.allergen.org) ([Table 49](#) and [Figure 104](#) and [106](#)). Wheat (*Triticum aestivum*) allergen numbers start with Tri a 12 (profilin) and end with Tri a 45 (Elongation factor 1 (EIF1)

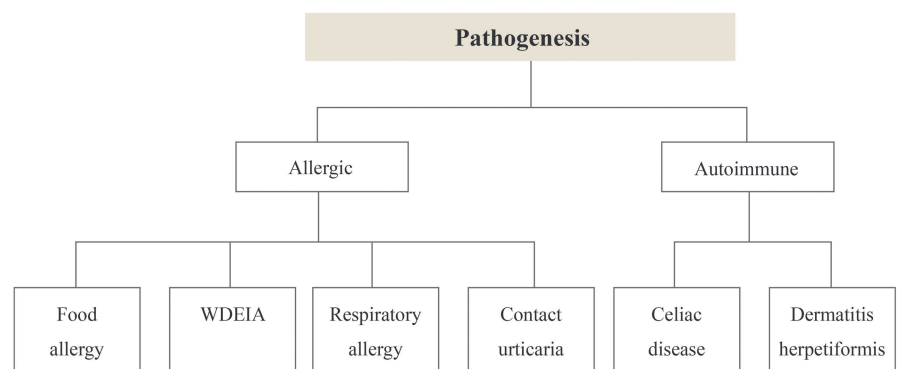


FIGURE 103 Classification of wheat-related allergic diseases. Modified from 1187

(serine protease inhibitor-like protein). Many of the not yet clinically well-studied allergens are homologous to characterized grass pollen allergens or seed allergens from related cereals. Wheat proteins have been broadly divided into water-soluble albumins, salt-soluble globulins, and insoluble prolamins, including the gliadins, which are soluble in aqueous alcohols, and the glutenins¹¹⁸¹ (Figure 105). The gliadins and glutenins are the major storage proteins in the wheat grain, also making wheat flour suitable for baking. Each of these fractions contains allergenic proteins, which have been associated with clinical symptoms, but as yet, there is no consensus definition

of major and minor allergens of wheat. Little is known also of the allergenicity as what comes to heating and processing of the fractions.

Sensitization to wheat among children was <1% in a systematic review taking into account a number of studies around the world¹¹⁴⁰. In a population-based study among six-year-old children in Britain, wheat sensitization rate was 0.4% and most of this was concluded to result from grass sensitization based on the food challenges.¹¹⁸² No studies have examined response to single proteins at population level.

Cross-reactivity of wheat comes at least from sensitization to grass pollen (Figure 107). It varies, however, how much of the sensitization can be explained on this at different age groups and in different disease conditions. Wheat is also highly cross-reactive with other cereals, mainly rye and barley. Oats belong to the same grass family but are more distantly related to wheat. Children with challenge-proven wheat allergy usually tolerate ingested oats despite frequent sensitization.¹¹⁸³ Early studies showed that prolamins like gamma-70 and gamma-35 secalins in rye and gamma-3 hordein in barley cross-react with omega-5 gliadin¹¹⁸⁴ and there are several other proteins among these three cereals, which are highly cross-reactive. Moreover, there is high sequence identity among many other proteins such as α -purothionins from wheat, rye, and barley (>80%).¹¹⁸⁵ In a large study of baker's allergy, rye flour inhibited binding of IgE to most wheat allergens at a significant level.¹¹⁸⁶

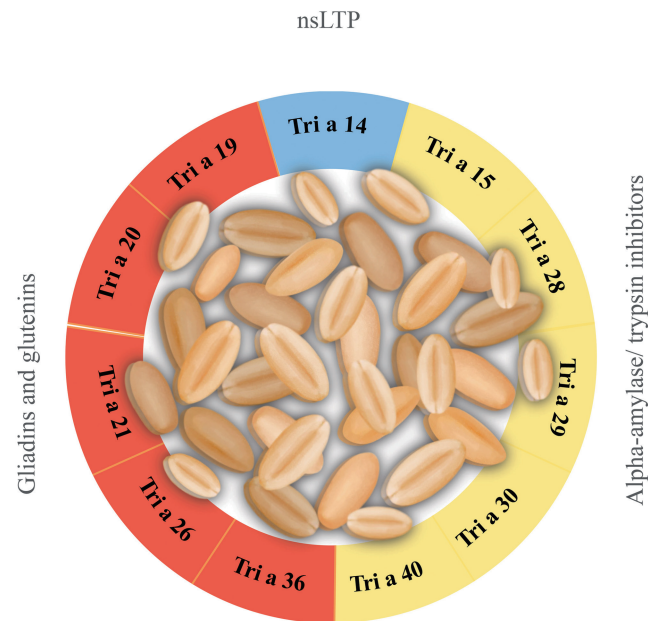


FIGURE 104 Allergen families and allergen proteins in wheat

4 - Sensitization to individual molecules and their clinical relevance

The best characterized single wheat allergen is omega-5 gliadin (Tri a 19), which is a major allergen for wheat-dependent, exercise-induced anaphylaxis (WDEIA), later in this document clinical

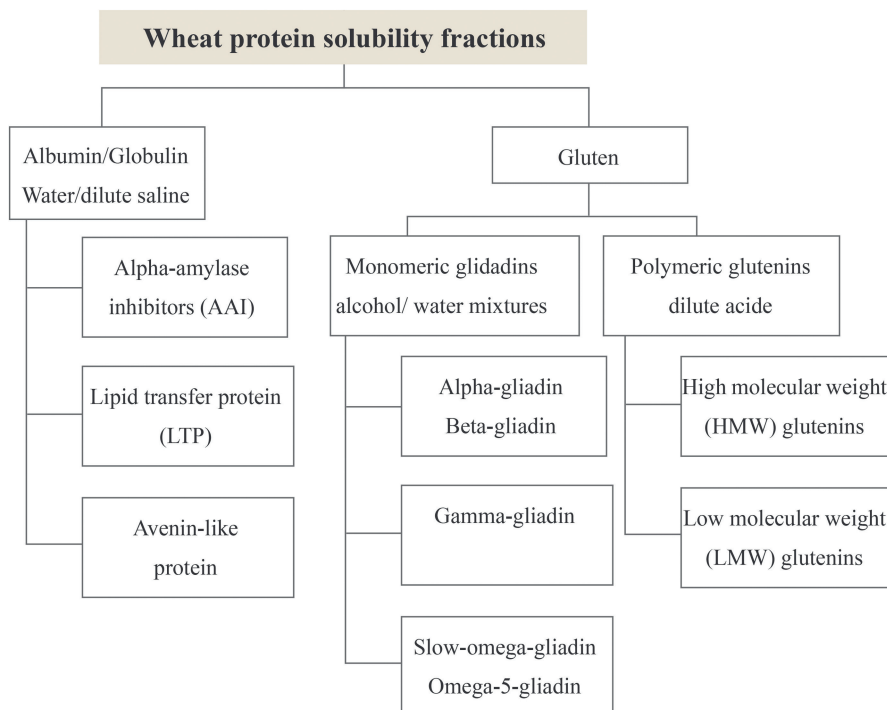


FIGURE 105 Allergenic molecules of wheat grouped according to their solubility

TABLE 49 Wheat allergens identified to date

Allergenic Molecule	Biochemical name	Prevalence among patients (%)	Molecular weight (kDa)	Heat stability
Tri a 12	Profilin	2.5% of patients with BA	14	Low
Tri a 14	Non-specific lipid transfer protein	10% of patients with BA	9	High
Tri a 15	Monomeric alpha-amylase inhibitor 0.29	41% in wheat allergy	56	High
Tri a 17	Beta-amylase	?	65	High in slightly acidic conditions
Tri a 18	Agglutinin isolectin 1	50-70% of wheat allergic patients, 80% in WDEIA	35-38	High
Tri a 19	Omega-5-gliadin, seed storage protein		30-45	High
Tri a 20	Gamma gliadin		13	Low
Tri a 21	Alpha-beta-gliadin	50-70% of wheat allergic patients	88	
Tri a 25	Thioredoxin	50-70% of wheat allergic patients,	27	
Tri a 26	High molecular weight glutenin	20% in WDEIA	13	High
Tri a 27	Thiol reductase homologue	50-70% of wheat allergic patients	13	High
Tri a 28	Dimeric alpha-amylase inhibitor 0.19	37% of wheat allergic patients	16	High
Tri a 29	Tetrameric alpha-amylase inhibitor CMI/CM2		26	
Tri a 30	Tetrameric alpha-amylase inhibitor CM3		40	
Tri a 31	Triosephosphate-isomerase		40-42	
Tri a 32	1-cys-peroxiredoxin	60-80% of wheat allergic patients	40	
Tri a 33	Serpin	16% of wheat allergic patients	12	High
Tri a 34	Glyceraldehyde-3-phosphate-dehydrogenase		15.96	
Tri a 35	Dehydrin			
Tri a 36	Low molecular weight glutenin GluB3-23			
Tri a 37	Alpha purothionin			
Tri a 39	Serine protease inhibitor-like protein			
Tri a 40	Chloroform/methanol-soluble (CM) 17 protein [alpha-amylase inhibitor]			
Tri a 41	Mitochondrial ubiquitin ligase activator of NFKB 1			
Tri a 42	Hypothetical protein from cDNA			
Tri a 43	Hypothetical protein from cDNA			
Tri a 44	Endosperm transfer cell specific PR60 precursor			
Tri a 45	Elongation factor 1 (EIF1)			

form B. It is also an important allergen in early childhood wheat allergy with immediate onset symptoms and atopic eczema (later A type)^{1184,1187-1189} and baker's asthma/allergy (type C).¹¹⁸⁶ Other relatively well-documented allergens include alpha-amylase inhibitors (AAI), the response to which is associated with both baker's allergy and food allergy,^{1181,1186} wheat LTP has also obvious clinical relevance and it has been associated with baker's asthma¹¹⁹⁰ and food allergy.¹¹⁹¹ So far, attempts to find single allergens predicting clinical reactivity have produced at best high sensitivity with the expense of low specificity. Although an early study showed up to 100% specificity for clinical response with sensitization to omega-5 gliadin,¹¹⁸⁷ later larger studies recruiting more heterogeneous patient groups have produced much lower rates for both sensitivity and specificity.^{1181,1189} There are many more relevant sensitizations to single proteins other than gliadins, AAI, or LTP. Two studies demonstrated the role of sensitization to both low-molecular-weight (LMW) Tri a 36 and the high-molecular-weight (HMW) glutenin, Tri

a 26 with the most typical type of childhood wheat allergy.^{1181,1189} Moreover, omega-5 gliadin is not the only gliadin that seems to be of significance. Also alpha-, beta-, and gamma-gliadins present as important allergens in several studies.^{1181,1189} Recently, based on construction of *T. aestivum* cDNA library and screening it with serum IgE from patients suffering from respiratory wheat allergy five novel wheat allergens were characterized: a thioredoxin h isoform, glutathione transferase, 1-Cys-peroxiredoxin, profilin, and dehydrin. Particularly of these, a potential and emerging food allergen is alpha-purothionin Tri a 37.¹¹⁸⁵ In the largest study of any wheat-allergic patients, 19 recombinant wheat flour proteins and 2 cross-reactive carbohydrate determinants were tested in sera of 101 bakers from several European countries with wheat flour allergy. Not a single allergen emerged as a major one and each baker showed an individual IgE-binding profile with great interindividual variation.¹¹⁸⁶ Taken altogether, there is generally a significant overlap of the responses to individual proteins in different disease conditions.

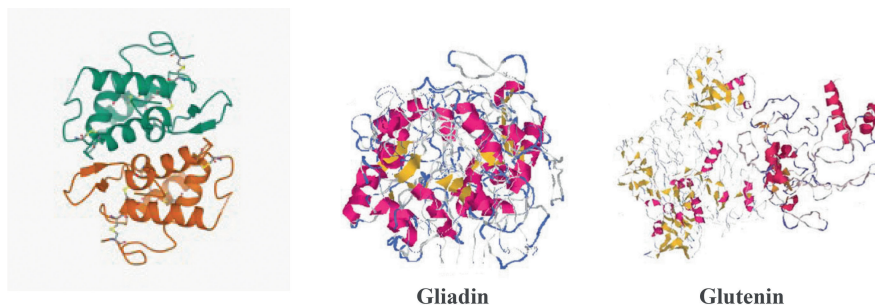


FIGURE 106 A. Tri a 28 0.19 alpha-amylase inhibitor B. Predicted protein structure of gliadin and glutenin. Figure edited from Rasheed et al. (RSC Adv., 2014,4, 2051-2060).

5 – Diagnosis of wheat allergy

Due to different routes and amounts of exposure four scenarios can prompt IgE-mediated sensitizations and clinical symptoms of immediate hypersensitivity¹¹⁷⁷ (Table 50A–D).

- A Typically, IgE-mediated form of food allergy to wheat is analogous to the symptoms seen in milk or egg allergy. Allergic individuals develop symptoms within minutes to 1–2 h after ingestion of wheat. The symptoms include urticaria, angioedema, erythema, pruritus, vomiting, abdominal pain, persistent cough, hoarse voice, wheeze, stridor, respiratory distress, nasal congestion, and, in most severe cases, anaphylaxis. These may be associated also with delayed-type symptoms, which include the worsening of atopic dermatitis, and gastrointestinal symptoms such as stomach pain and diarrhea or loose stools. Early presumably gastrointestinal or cutaneous sensitization to rather stable wheat allergens (e.g., omega-5 gliadin, HMW glutenin, LMW glutenin, alpha-amylase inhibitor) in often atopic infants is the basis of most typical IgE-mediated wheat allergy, extending often until school age and in rare cases, up to adulthood.
- B Wheat-dependent, exercise-induced anaphylaxis (WDEIA) means the appearance of severe symptoms after ingestion of wheat followed by physical exercise typically among young adults. Symptoms vary from generalized urticaria to severe anaphylactic reactions. Sensitization to omega-5 gliadin is the most specific marker for the disease, but the patients are sensitized also to several other wheat allergens. This is an important albeit a not highly prevalent form of wheat allergy.
- C Baker's allergy or asthma comes from inhalation of the wheat flour. At the moment, the test allergen with most sensitivity but low specificity is whole-wheat flour (including all allergens). The specificity of testing can be improved by component-specific analysis.
- D Contact urticaria is associated with the use of cosmetics and also sometimes together with food allergy. Hydrolysis of wheat is carried out to overcome its insolubility in cosmetics and exposure to hydrolyzed wheat protein (HWP) can cause either contact urticaria or even anaphylaxis when consuming.

Skin prick test to wheat: Commercial wheat extract or in-house solution employing wheat flour can be used for skin prick testing (SPT). Some authorities have claimed that this should not be used at all due to the very low specificity for all types of wheat allergy.

Specificity can be improved by additional testing to omega-5 gliadin (dissolved in ethanol, in-house preparation) or other gliadins. For clinical pattern D, hydrolyzed wheat protein should be tested. There is little experience in SPT testing for other single proteins.

Specific IgE testing: Whole wheat extract, Tri a 14, Tri a 19, gliadins are commercially available for determination of allergen-specific IgE. Wheat extract has low specificity and high sensitivity and can be useful in clinical patterns A–C. Omega-5 gliadin and gliadins (alpha, beta, gamma) can be useful for clinical patterns A and B. Lipid transfer proteins (Tri a 14) for A and B, probably have no cross-reactivity with grass pollen although there are not enough data to exclude this. Measuring sensitization may help in differentiating wheat sensitization from pollen allergy in patients with high levels of grass pollen-specific IgE, but this not very sensitive. AAIs, particularly dimeric 0.19, LMW and HMW glutenins, Tri a 37 can be useful for clinical patterns A and C. The combination of Tri a 27, 28, 29, 39, and 32 for clinical pattern C.

Oral food challenges: Clinical pattern A mainly: various protocols with whole wheat can be used, for example, challenge in children with wheat flakes containing porridge or bread¹¹⁸¹. Start with a low dose (1–50 mg) of wheat-specific protein. A suitable time interval between the increasing doses should be an hour (digestion of wheat may be slower than milk and egg). Continue with semi-logarithmic progression steps up to at least 1 g of cumulative dose of wheat protein. Also, double-blind placebo-controlled protocols have been published both for children and adults.^{1181,1192}

Clinical patterns B and C: usually case history and IgE testing is enough for diagnosis. In uncertain cases such as in idiopathic anaphylaxis, carefully monitored exercise challenge with high readiness treatment of anaphylaxis after wheat ingestion may be considered. Some centers have used ASA or alcohol as an additional provoking factor instead of exercise.¹¹⁹³

Clinical pattern D: challenge on the skin with HWP containing cream. Of note, B and D may be seen in the same patient (Figure 108).

6 – Clinical management of wheat allergy

Advice and avoidance: Patients with severe wheat allergy should be discouraged to try different forms of wheat. There is no evidence of reduced allergenicity between different species of wheat such as spelt. Little is known of changes in allergenicity during

FIGURE 107 Cross-reactivity with wheat allergens

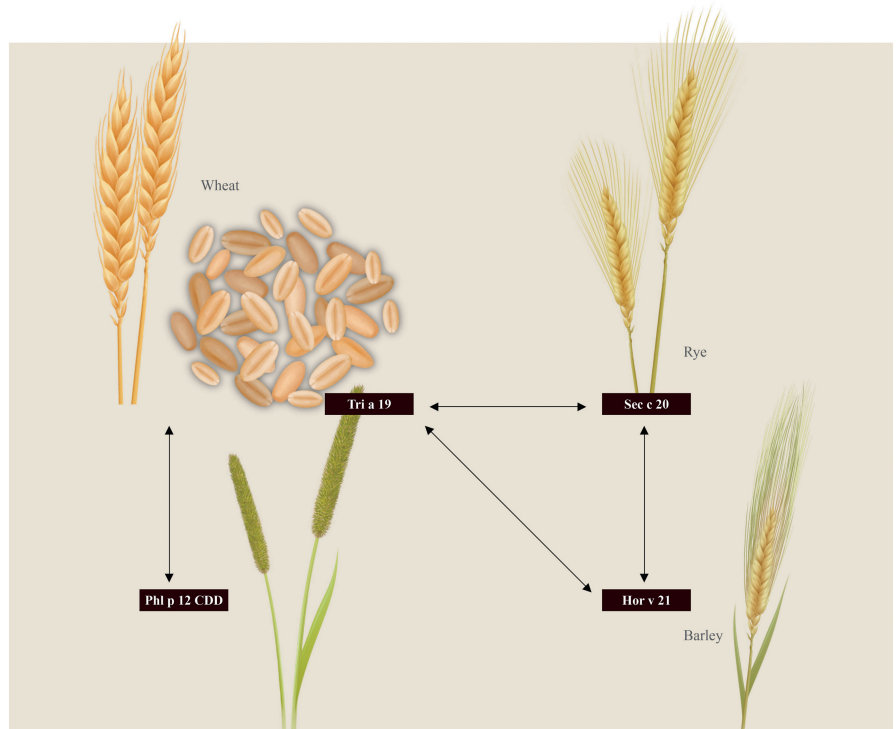


TABLE 50 Clinical patterns of different types of wheat allergy

A	B	C	D	
Routes of sensitisation (development of an allergen-specific IgE immune response)	Gastro-intestinal (or cutaneous) uptake of wheat proteins with subsequent or concomitant IgE-sensitisation to stable proteins	Gastro-intestinal uptake of wheat proteins with sensitisation to especially omega-5-gliadin	Inhalation of wheat flour and dust during grain processing and subsequent sensitisation to water-soluble allergens	Use of local cosmetics on the skin
Affected (age) group	Infants/children/rarely adults	Adults/adolescents	Exposed workers, typically bakers	Adolescents/adults
Wheat allergens involved	Gliadins (ω -5-gliadin) most important (?) HMW glutenins LMW-glutenins AAI's	ω -5-gliadin, LTP (tri a 14)	Combination to Tri a 27, 28, 29, 39, 32 gives highest sensitivity and specificity Sensitisation to several other allergens including AAI's (particularly Tri a 15 and 30), Tri a 21 and 33 common	Hydrolyzed wheat protein (HWP)/gluten
Allergen abundance	Several others with varying sensitisation rate	Not known	Common in cosmetics	
Thermal stability	High	High	Low?	High?

Digestive stability	High	High	Low?	
Prevalence (North and Middle Europe)	High	Low	Low?	Low
Prevalence (Southern Europe)	Moderate	Low	Low?	Low
Elicitators (products)	All wheat products	Ingested wheat prior to exercise	Wheat flour and dust in the air	Hydrolyzed gluten in cosmetics such as facial soap
Symptoms	Quick onset (minutes to 2 h) of potentially severe systemic reactions with various symptoms of anaphylaxis: mucosal (i.e. oropharyngeal), cutaneous (urticaria, angioedema, eczema flaring), airway-related (upper and lower airways), gastrointestinal and/or cardiovascular symptoms	Quick onset urticaria, angioedema, and/or systemic symptoms of anaphylaxis	Airway symptoms (i.e. allergic rhinoconjunctivitis and asthma symptoms) within few hours of exposure	Typically urticaria after application of the cream/soap. Ingestion of foods containing deamidated gluten can cause systemic reactions including anaphylaxis
Additional clinical features	Atopic eczema (infants with wheat allergy), reactions after other cereals including rye and barley, rarely oats	Alcohol consumption enhances responsiveness		Usually patients do not have other types of wheat allergy
Medical diagnosis	Obvious and repeatable food allergic reaction to wheat (porridge, bread, pasta etc.)	Symptoms and history, sensitisation to omega-5-gliadin, in some cases challenge test	Allergic asthma and rhinoconjunctivitis due to wheat protein inhalation	Obvious contact urticaria when using HWP containing products. Patients can also develop type A food allergy.
Type of food allergy	Class 1	Class 1	Primary inhalant allergy	Class I
Avoidance	No oral intake of wheat at significant amounts (milligram levels)	No ingestion of wheat	Occupational avoidance strategies in situations of large wheat protein exposure	Cosmetics containing HWP, in those with systemic reactions avoidance of HWP in food
Product declaration	Mandatory on each wheat-containing product (EU law)	Mandatory on each wheat-containing product (EU law)		
Technical solution	No general technical solution available	No technical solutions	Dust extractor in occupational settings	

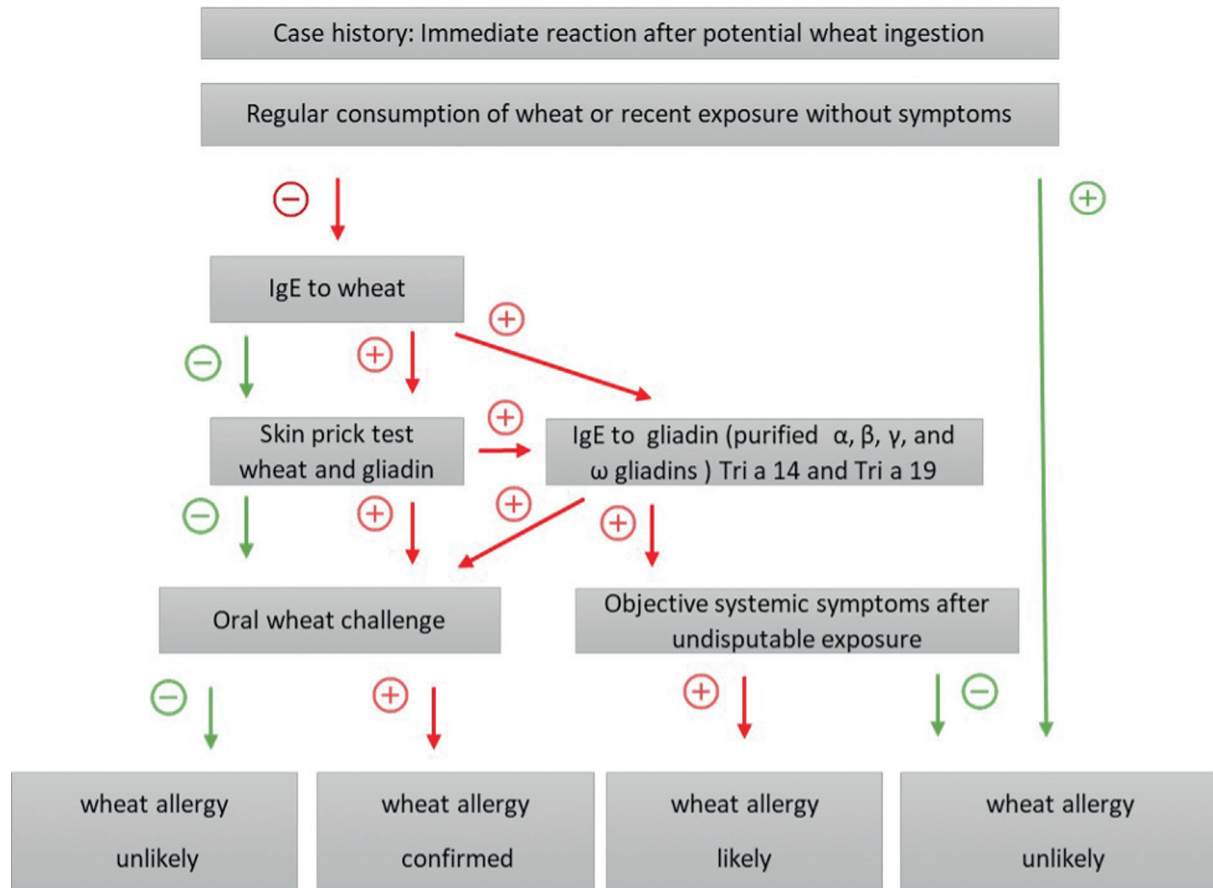


FIGURE 108 Diagnostic algorithm for wheat allergy

processing. Below is the advice tailored to the clinical patterns previously identified

- A Avoidance of all wheat-containing products, the level of avoidance can be titrated according to symptoms. Those with anaphylaxis should avoid products even with small amounts of wheat. Those with delayed symptoms and IgE negative to wheat should be encouraged to use the maximal dose not eliciting symptoms.
- B Avoidance of all gluten-containing wheat especially if co-factors present
- C Avoidance of inhalation of wheat containing proteins.
- D Avoidance of cosmetics with hydrolyzed wheat protein.

Pharmacotherapy for treatment of accidental reactions: All wheat allergic patients should be prescribed treatment for acute allergic reactions and be given a detailed treatment plan. Below is the treatment adapted to the clinical patterns previously identified.

- A For those with delayed reactions or mild systemic reactions, antihistamine at age-dependent dosages is enough. Because of the rapid absorption of cetirizine as compared to other antihistamines such as loratadine or desloratadine, it may be the antihistamine of choice. For those with a history of severe reactions in food challenge or after unintentional ingestion of wheat-containing products, the use of adrenaline autoinjector should be instructed carefully

- B Adrenaline autoinjector.
- C Symptomatic treatment as required for rhinitis/asthma.

Allergen-specific immunotherapy: At present, there are no commercially available products for allergen-specific immunotherapy. Clinical studies are being carried out on oral immunotherapy for clinical pattern A but, as to date, there are not enough published data to draw conclusions on the proper product to use or adequate protocols. A small case series with three patients with clinical pattern B in whom sublingual immunotherapy was conducted was published recently and individual thresholds of all patients increased after treatment.¹¹⁹⁴

7 – Prognosis of wheat allergy

The studies on the prognosis of wheat allergy have demonstrated a high rate of spontaneous resolution of the symptoms in children similar to that of milk or egg allergy.^{1189,1195} In one study, sensitization to gliadins correlated best with persistent wheat hypersensitivity and the development of asthma in children.¹¹⁸⁹ In a Japanese study, an anaphylactic reaction before the age of 3 years and high levels of wheat- or ω-5 gliadin-specific IgE increased the risk of persistent wheat allergy.¹¹⁹⁶ Generally, high levels of wheat-specific IgE predict slower resolution and those with IgE-negative allergy are

clinically tolerant by age three. Taken altogether, children should be challenged at certain intervals, in early childhood yearly, to test for development of tolerance. WDEIA and baker's asthma do not show spontaneous resolution.

8 – Clinical Cases

Case 1

Clinical History: A 9-year-old boy. Atopic dermatitis since early infancy. First obvious reactions to wheat (skin flares with eczema, urticaria) soon after start of wheat at 6 months. First anaphylactic reaction to wheat at 2 years of age with generalized urticaria, bronchial obstruction, and vomiting. Strict avoidance and adrenaline autoinjector continued until now. Developed also birch allergy at 2 years of age and later other pollen sensitizations. Avoids some fresh vegetables such as cucumber, pea, nuts, and banana due to oral allergy syndrome symptoms. The family wants to know whether to continue avoiding wheat or not.

Tests with extracts: Wheat-specific IgE was 390 kU/l. In SPT whole-wheat extract 9 mm, omega-5 gliadin 7 mm, rye 5, barley 5, oat 0. Birch 7 mm, timothy grass 5 mm

Tests with molecules: Specific IgE for omega-5 gliadin 18 kU/l, timothy grass 40 kU/l, birch 100 kU/l

Food challenge: Wheat porridge 1 ml (=13 mg wheat protein) as a starting dose: mild tickling in the mouth, which resolves spontaneously. With doubling the dose, the boy starts vomiting, complains of nasal obstruction

Conclusion: Wheat allergy. Complete avoidance of wheat, adrenalin autoinjector guidance for the boy and all caretakers.

Case 2

Clinical History: A 30-year-old female nurse. Generally healthy and mild pollen allergy. During the last few years, occasional urticaria which the patient has sometimes linked to wheat ingestion (bread, pasta). Occasionally urticarial appearance after brisk walk or jogging.

Tests with extracts: Wheat-specific IgE 20 kU/l. In SPT, whole-wheat extract 5 mm, omega-5 gliadin 7 mm, rye 3 mm, barley 3 mm, oat 0 mm.

Tests with molecules: Omega-5 gliadin (Tri a 19) 10 kU/l.

Food challenge: Large amount of pasta ingested. One hour later, a nurse-controlled free-field running test for 6 min was performed. During the last 2 min patient starts complaining severe itching and develops rapidly massive generalized urticaria, no signs of bronchial obstruction or severe gastrointestinal symptoms. Receives adrenalin, which relieves urticaria (see [Figure 109](#) after one adrenalin injection). The urticaria starts increasing again in 15 min, and the patient receives another adrenalin shot. After this, the urticaria is resolved, and the patient feels fine.

Conclusion: wheat-dependent, exercise-induced urticaria. 4 h after ingestion of wheat no exercise including brisk walking.

Case 3

Clinical History: A 37-year-old female cook who later studied to become pastry chef/ baker. After 2 years of working as a baker,



FIGURE 109 Severe urticaria on the whole body seen in a young woman after wheat ingestion and exercise challenge

the patient started experiencing nasal symptoms first from rye flour and later from wheat and malt flours. No asthmatic symptoms at any time.

Tests with extracts: In-house immunoassay with the working place dust from wheat flour and rye flour positive. Wheat IgE 2.1 kU/l, rye 0.8 kU/l. In SPT, whole-wheat extract 0 mm as were the other cereals.

Challenge: Chamber challenge with wheat flour induced nasal symptoms and also increase in nasal resistance (acoustic rhinomanometry).

Conclusion: Occupational allergic rhinitis due to wheat and rye (baker's allergy). Primarily a respiration filter and change of the station in the kitchen. This did not help this patient enough, so she is considering to learn a new profession.

9 – Research and future perspectives

Clinically irrelevant sensitization to wheat is common and the diagnostic accuracy of wheat protein extracts is unsatisfactory. At present, there are three commercially available allergens for diagnostic purposes: gliadin (including purified α , β , γ , and ω -gliadins) Tri a 14 and Tri a 19. In addition, the ImmunoCAP ISAC contains purified alpha-amylase/trypsin inhibitor (nTri a aA_TI). However, no single allergen can be used for molecular allergy diagnostics, since the IgE response in wheat allergy is heterogeneous and directed against multiple allergens.

Detailed knowledge on the structure and immunologic properties of clinically relevant wheat allergens is needed to develop accurate diagnostic tools for wheat allergy. The complex protein structure of wheat gliadins and glutenins and their insolubility in aqueous solutions has, however, posed challenges on protein purification and structural analysis. Identification and characterization of clinically relevant IgE-binding epitopes in different forms of wheat allergy could possibly improve the accuracy of molecular allergy diagnostics.

Buckwheat allergy

Highlights: Buckwheat allergy

- Allergic reactions to buckwheat may occur after ingestion, inhalation, or when handling buckwheat.
- Clinically irrelevant sensitization to buckwheat is common and the diagnostic performance of IgE to buckwheat extract and skin prick tests is low. Although buckwheat allergy is relatively infrequent, it can often cause anaphylactic reactions. IgE to Fag e 2 is associated with severe reactions, but well-defined commercially available buckwheat allergens for molecular allergy diagnostics are lacking.
- The popularity of buckwheat as a healthy, gluten-free food has increased in the European countries and USA. Buckwheat is often consumed as a hidden food allergen. Remember the possibility of buckwheat allergy when investigating unclear anaphylaxis, especially in patients on a gluten-free diet.

1 – The allergen sources

Two buckwheat species, originating from China, common buckwheat (*Fagopyrum esculentum*) and tartary buckwheat (*Fagopyrum tartaricum*) are cultivated globally for food production. This chapter focuses on common buckwheat, which is the dominant species. It is widely consumed in Asia and Russia with increasing popularity in western countries, because of its high nutritional value and suitability for individuals with gluten-related disorders¹¹⁹⁷ [25, 26]. Buckwheat can be consumed as groats, and buckwheat flour is used in many foods such as noodles, bread, pastry, pancakes, blinis, and porridge. Buckwheat is often present as a hidden food allergen since there is no regulation on allergen labeling for buckwheat apart from Japan and Korea.¹¹⁹⁸ Buckwheat husks are used for pillow fillings and common buckwheat is added to animal feed.¹¹⁹⁹

Allergic reactions to buckwheat may occur after oral ingestion, inhalant exposure when producing or handling buckwheat, or when sleeping on buckwheat husk pillows. The symptoms include typical food allergy symptoms affecting the skin, gastrointestinal tract, and respiratory system as well as severe systemic reactions including anaphylaxis.¹¹⁹⁹ Allergic rhinitis, asthma, and contact urticaria have been described in the occupational setting.¹²⁰⁰

2 – Allergen families

Buckwheat is a pseudocereal that belongs to the Polygonaceae family. It is a grain-like seed, which shares similarities with cereal grains. Allergenic proteins in buckwheat are mainly seed storage proteins (2S albumins, 7S globulins, and 11S globulins), which belong to the prolamin and cupin superfamilies.¹²⁰¹ Taxonomically buckwheat is unrelated to wheat.

3 – Allergenic molecules

Several buckwheat allergens have been identified and characterized (Figure 110 and Table 51).¹²⁰² The World Health Organization/International Union of Immunological Societies Allergen Nomenclature Sub-Committee lists five common buckwheat allergens named Fag e 1 to 5 and two tartary buckwheat allergens named Fag t 1 and Fag t 2. (<http://www.allergen.org/>) Buckwheat allergy has been reported mainly in Asia with an estimated prevalence of 0.1% in Korea and 0.22% in Japan where it is the sixth most common cause of food allergy.¹¹⁹⁹ In Japan, buckwheat causes approximately 3% of all reported anaphylactic events to foods,¹²⁰³ and in a study including school-aged children more than half presented with anaphylaxis.¹²⁰⁴ The prevalence of buckwheat allergy may be higher in certain subgroups, for example, in patients with coeliac disease. Sensitization rates to buckwheat in the European countries and the United States vary from 1% to 9.7%, but the prevalence of true buckwheat allergy is unknown.^{1199,1205}

4 – Sensitization to individual molecules and their clinical relevance

Studies have focused on common buckwheat where Fag e 1, 2, and 3 are considered the major allergens. Fag e 1 is the β -subunit of 13S globulin (legumin), which in early studies was recognized by all patients with buckwheat allergy.¹²⁰⁶ Later studies showed higher diagnostic performance for the full-length protein, when comparing the purified native full-length legumin and its subunit designated as

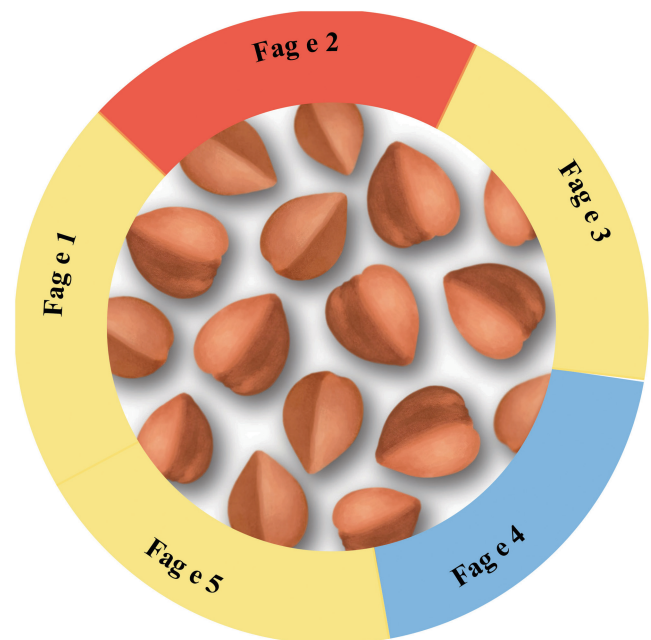


FIGURE 110 Allergen families and allergen proteins in buckwheat

TABLE 51 Buckwheat allergens described to date

Allergenic Molecule	Biochemical name	Prevalence among patients (%)	Molecular weight (kDa)	Heat stability
Fag e 1	13S globulin / legumin	?	22	
Fag e 2	2S albumin	76-87	16	High
Fag e 3	7S globulin / vicilin-like	83	19 (fragment)	
Fag e 4	Antimicrobial Peptide	71	3.9	
Fag e 5	Vicilin-like protein		55	
Fag t 2	2S albumin	38	16	High
Fag t 6	Oleosin	60	18	

Fag e 1. This suggests that not all relevant IgE-binding epitopes are present in the legumin subunit Fag e 1.¹²⁰⁷

Fag e 2 is a highly stable 2S albumin that is resistant to pepsin digestion in contrast to Fag e 1 and Fag e 3. Sensitization to Fag e 2 is often related with severe reactions including anaphylaxis and it is thus considered an important allergen in buckwheat anaphylaxis.¹²¹³⁻¹²¹⁵ In a small Danish cohort, including 11 patients with severe buckwheat allergy Fag e 2 on ImmunoCAP ISAC showed a relatively high specificity (96%) but low sensitivity (43%). In ELISA, the diagnostic specificity of Fag e 2 was 85% and sensitivity 100%.¹²¹²

Fag e 3 is a 7S globulin, which is the N-terminal fragment of a vicilin-like protein. Fag e 3 has weak homology to the vicilin-like allergens of cashew (Ana o 1), English walnut (Jug r 2), and 7 S globulin from sesame seed. Studies from Japan have reported Fag e 3 as the most specific allergen for the diagnosis of patients with clinical symptoms of buckwheat allergy.¹²⁰⁷ Fag e 3 had a higher diagnostic performance at the optimal cutoff than buckwheat extract and had the best clinical performance among the buckwheat allergens studied. In a group of 60 Japanese children sensitized to buckwheat, Fag e 3 predicted oral food challenge results as well as anaphylaxis.¹²⁰⁹ Two recently described allergens include Fag e 4, a hevein-like antimicrobial peptide that is potentially cross-reactive with latex, and Fag e 5, a partial peptide of a vicilin-like protein.¹²¹² In the Danish cohort of 11 buckwheat allergic patients and 41 sensitized nonallergic patients, concomitant sensitization to Fag e 1, Fag e 2, and Fag e 5, was the best predictor of clinical buckwheat allergy. Interestingly, in this population, sensitization to Fag e 3 was not observed.¹²¹²

5 – Diagnosis of buckwheat allergy

The diagnosis of buckwheat allergy begins with a careful assessment of clinical history (Figure 111). In suspected buckwheat allergy, sensitization can be screened by skin prick testing or the measurement of buckwheat-specific IgE. Despite high sensitivity, the specificity of these tests is rather low, and clinically irrelevant sensitization to buckwheat is common. Thus far, the only commercially available allergen component for molecular allergy diagnostics is Fag e 2 in the

ImmunoCAP ISAC microarray. Sensitization to buckwheat extract and Fag e 2 together with a positive clinical history increases the probability of buckwheat allergy. The absence of sensitization to Fag e 2, however, does not rule out clinical reactivity, because in many cases other buckwheat allergens (e.g., Fag e 1, 3, and 5) are involved. The diagnosis should thus be confirmed by an oral food challenge unless there is a recent history of a severe reaction to buckwheat.

6 – Clinical case

Clinical History: a 3-year-old boy with atopic eczema since infancy, which required daily treatment with emollients and periodic topical corticosteroids. He had experienced recurrent episodes of wheezing during respiratory infections and used regular controller treatment for asthma. His diet was unrestricted until 2 years of age, after which his parents started a gluten-free diet because allergy testing revealed low sensitization to wheat (wheat-specific serum IgE 2.33 kU/L). Wheat avoidance seemed to alleviate his atopic eczema. He experienced anaphylaxis after eating a gluten-free bread containing buckwheat, rice, and corn. The symptoms started 30 minutes after ingestion: generalized urticaria, wheezing, and vomiting. He was treated at the emergency room with intramuscular adrenaline, oral antihistamines, and inhaled salbutamol.

Tests with extracts: The patient had positive results for buckwheat (15.7 kU/L) and wheat (6.81 kU/L) extracts. In SPT buckwheat was 7 mm, wheat 3 mm, and gliadin was negative. Specific IgE and SPT for rice and corn were negative.

Food challenge: An oral buckwheat challenge was not performed because of a recent anaphylactic reaction after ingestion of buckwheat. An open oral wheat challenge with a cumulative dose of 1600 mg protein was negative.

Test with molecules: ImmunoCAP ISAC was positive for Fag e 2 (2.9 ISU). Wheat Tri a 14, Tri a 19, and Tri a aA/ TI (alpha amylase/trypsin inhibitor) were negative.

Conclusion: Buckwheat allergy presenting with anaphylaxis. Clinically irrelevant sensitization to wheat.

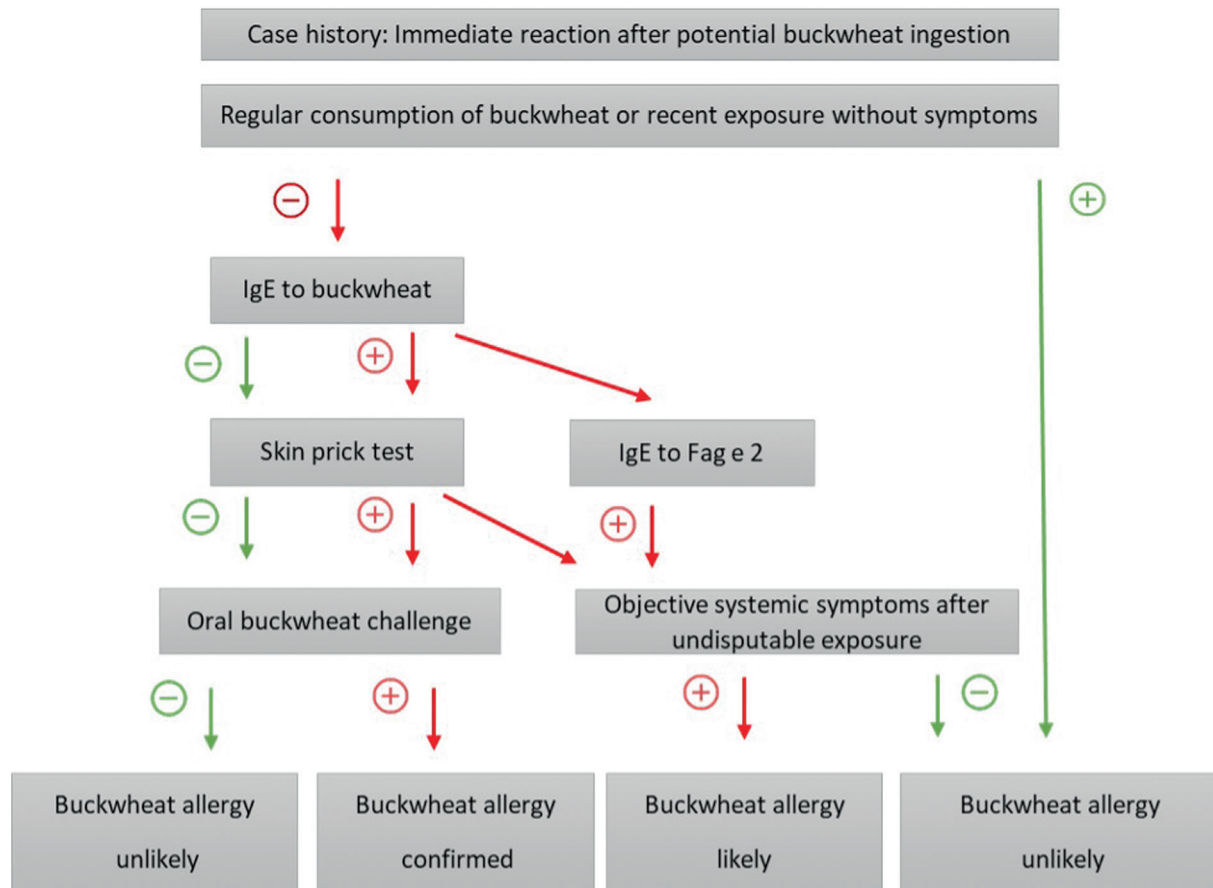


FIGURE 111 Diagnostic algorithm for buckwheat allergy

7 – Research and future perspectives

Buckwheat allergy is relatively infrequent but often associated with severe reactions and anaphylaxis. Although reports of buckwheat allergy are mostly from Asian countries, it is becoming an increasing problem in Europe. Buckwheat is often present as a hidden allergen in e.g., bakery products, since it does not require labeling as a food allergen in Europe. Several buckwheat allergens have been identified;

however, their clinical relevance has been studied only in a limited number of patients, and sensitization profiles display geographical variation. Well-defined buckwheat allergens available for molecular allergy diagnostics for clinicians are still lacking. To date, the only commercially available allergen is Fag e 2 on the ImmunoCAP ISAC microarray. Further studies in a larger set of patients from different geographical areas and populations are essential to develop accurate diagnostic tools for buckwheat allergy.

B17 - Soy allergy

1 - The allergen sources

Sakura Sato, Kirsten Beyer, Motohiro Ebisawa

Highlights

- Allergic reactions to soy are caused by exposure to whole bean products, protein products, and unprocessed soybeans.
- Soy allergens can induce food allergy and inhalant (occupational) allergies.
- In areas with Fagales pollen exposure, Bet v 1-cross-reactive soy allergen, Gly m 4, induces the most common soy allergy.
- Oropharyngeal and sometimes severe reactions to Gly m 4 are limited to fresh, hardly processed soy protein containing products.

Soybeans are a legume species, which are a rich and inexpensive nutritional source used in many dishes and processed foods. They are native to East Asia and are most widely produced in the United States, followed by South America and Asia. Fat-free (defatted) soybean meal is a source of protein for many packaged meals, including textured vegetable protein and animal feed (Figure 112).

Soybeans are grouped within the “big eight” foods and are an important source of various allergens (Table 52), responsible for 90% of all allergic reactions to soy.¹²¹⁶ Allergic reactions have been described after exposure to whole bean products, protein products, and unprocessed soybeans.^{1216-1219,1222} Occasionally, severe allergic reactions in children have been attributed to whole bean

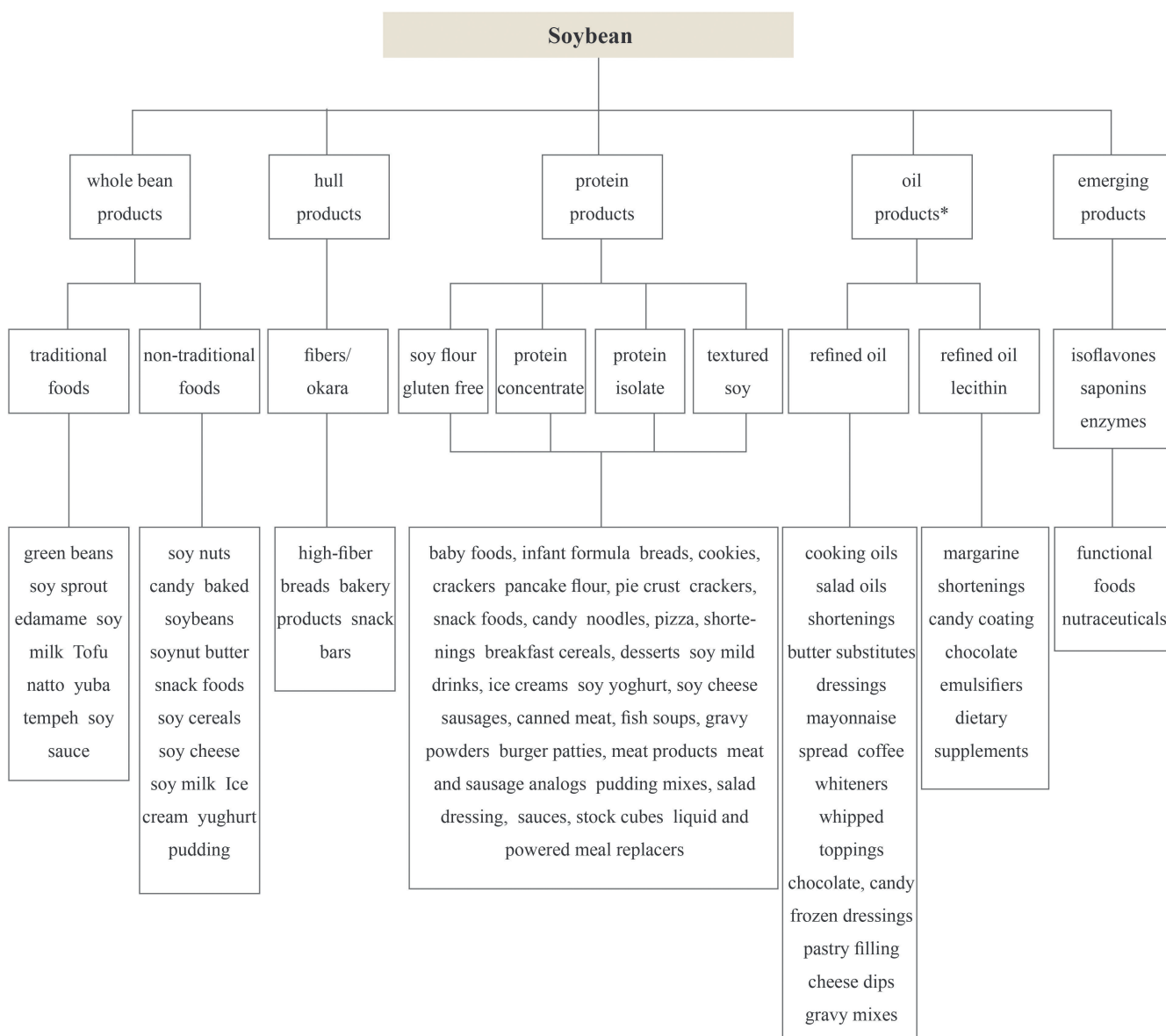


FIGURE 112 Soybean foods and ingredients *The protein content is minimal.

products, processed soy containing foods, and some suggested soy proteins.^{1215,1216} Birch pollen allergic individuals have recognized allergic reactions after ingestion of hardly processed dietary soy powder-containing or soy drink products.^{1213,1217-1219} These symptoms due to IgE-related cross-reactivity are the most common type of soy allergy in regions with relevant birch pollen or alder pollen exposure.^{1218,1220,1221} Oral symptoms are the most common, but systemic symptoms often develop after drinking soy milk.^{1220,1221} Harbour workers and citizens in close vicinity have developed inhalant allergies caused by high exposure and inhalation of raw unprocessed soybeans during the unloading of freight ships.^{1225,1226,1227}

2 – Allergen families

Soy allergens belong to diverse protein superfamilies, such as prolamins (2S albumin and lipid transfer proteins (LTPs), cupins (7S globulin and 11S globulin), profilins, and Bet v 1-like pathogenesis-related (PR)-10 proteins, among others (Table 52). They are characterized by conserved three-dimensional structures leading to broad immunological IgE-mediated cross-reactions among different members of the legume family or other plant foods.

3 – Allergenic molecules

Eight soy proteins most commonly involved in allergic reactions to soybean have been identified and officially accepted by the IUIS Allergen Nomenclature Sub-Committee (Table 52, Figure 113). Gly m 1 (nsLTP) and Gly m 2 (defensin) are associated with asthma after the inhalation of soybean dust. In a region where soybeans are loaded and handled, Gly m 1 levels were found in dust.¹²²⁵ Gly m 3 belongs to the profilin superfamily, and Gly m 4 belongs to the Bet v-1-like superfamily. Gly m 4 (and possibly Gly m 3) are underrepresented in diagnostic soybean extracts, leading to vast differences between extract and single allergen-based IgE results.¹²²⁶ In addition, the (low) presence of Gly m 4 (and Gly m 3) in soybean extracts obscures the differentiation of food reactions to stable allergens (i.e., Gly 5^{1222,1230}, Gly m 6^{1232,1235} and Gly m 8)^{1235,1232} and cross-reactions to the Bet v 1-homologue in soy, as demonstrated in cohort studies with atopic children.¹²²⁸ Gly m 5 and Gly m 6 belong to the cupin superfamily, and Gly m 8 belongs to the prolamine superfamily. These allergens are well represented in soy extracts and are associated with severe allergic reactions to soy in children^{1227,1229} and adults¹²¹⁹ based on their high resistance to heat and digestive enzymes.

TABLE 52 Soybean allergens (Only allergens approved by WHO/IUIS; www.allergen.org, 08-09-2021)

Allergen name	Protein name	Other names	Molecular weight (kDa)	Heat stability
Gly m 1	Hydrophobic protein (Shell)	Lipid transfer protein (LTP)	7	?
Gly m 2	Defensin		8	Low?
Gly m 3	Profilin		14	Low
Gly m 4	Bet v 1	Pathogenesis-related protein (PR)-10	17	Low
Gly m 5	7S globulin	Beta-conglycinin, Vicilin	48-65	High
Gly m 6	11S globulin	Glycinin, Legumin	52-61	High
Gly m 7	Seed biotinylated protein		76.2	?
Gly m 8	2S albumin		28	High

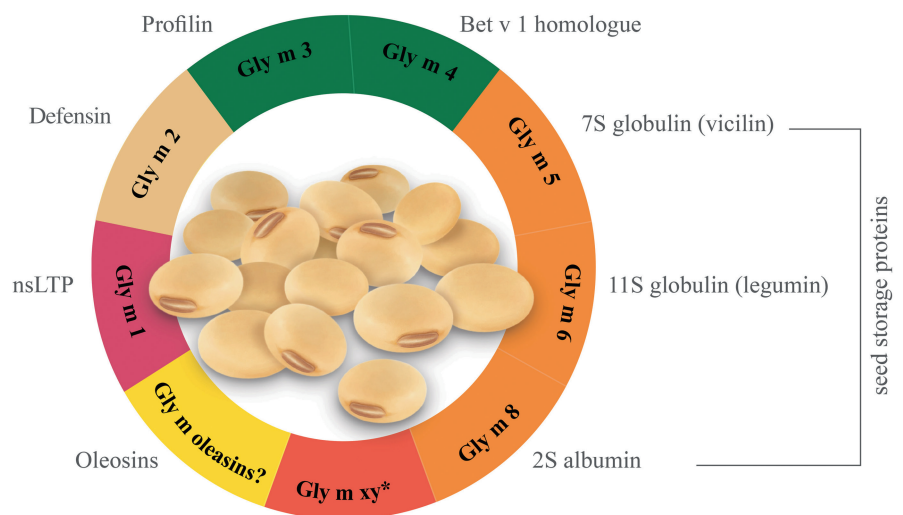


FIGURE 113 Major and relevant minor allergenic molecules from soy

4 – Sensitization to individual molecules and their clinical relevance

Previous sensitization rates were mainly based on skin or IgE testing of whole soybean extracts. Sensitization rates are available only for Gly m 4–6,¹²²⁶ while those of Gly m 1–3 and Gly m 7–8 are still lacking.

A systematic review summarized the analysis of sensitization rates in children.¹²¹⁵ In 40 studies, the weighted prevalence of soy allergy in children was reported to be 0.27% for the general population, 0.4% and 3.1% (1.9%) for the referred population, 2.7% for IgE-sensitized children.¹²¹⁵ IgE testing in a large cohort of German subjects aged 3–17 years revealed allergen-specific IgE to soybean extract in 6.3% of the cohort.⁷⁹⁸ A similar approach in German adults revealed sensitization rates of 3.7% for soybean extract and 10.3% for soybean allergen Gly m 4.¹²²⁶ Sensitization rate varies according to age and region. A large allergic Mexican population was positive for soybean in different age groups, and the positivity rate was lower in young children (≤ 5 years) than in older children (6–17 years).¹²³⁰ A study in a cohort of Japanese children revealed that the sensitization rate of Gly m 5 and Gly m 6 did not change significantly between the ages of five and nine, but Gly m 4 sensitization rate was increased.¹²³¹

Notably, conclusions on primary sensitization rates are hampered by highly cross-reactive, labile soybean allergens of low abundance: the Bet v 1-homologue Gly m 4, and soybean profilin Gly m 3 (i.e., presumably in regions with high grass pollen exposure and subsequent sensitization to grass profilin).

5 – Clinical patterns of soy allergy

Due to the different routes and amounts of exposure, degree of soybean processing, and physicochemical properties of the involved soybean protein allergens, three distinct scenarios (Table 53A–C) can be seen in IgE-mediated sensitization and clinical symptoms of immediate hypersensitivity.

- A Early, presumably epicutaneous or intestinal sensitization to rather stable allergens (i.e., Gly m 5,^{1219,1227} Gly m 6^{1227,1235} and Gly m 8^{1229,1232}) in atopic individuals are the basis of subsequent severe systemic reactions after ingestion of small amounts of soy or processed soy products.^{1211,1212} IgE sensitization could also evolve from exposure and subsequent IgE sensitization to more than one legume (i.e., peanut and soy), prompting symptoms occasionally after ingestion of peanut or other soy products. These rare reactions have mainly been described in young infants^{1230,1232} but are seldomly reported in adults.^{1219,1222}
- B Exposure to Fagales pollen in atopic individuals developing Bet v 1-specific IgE with variable degrees of cross-reactivity to soybean PR-10 protein Gly m 4, potentially inducing mainly oral mucosal and sometimes systemic allergic symptoms after consumption

of mildly processed soy products (soy protein powder, soy milk, etc.) in approximately 10% of birch pollen-sensitized subjects could occur.^{1216,1658,1659} Moreover, these individuals are likely to have very high specific IgE levels to birch pollen.^{1213,1650,1651} This type of soy allergy due to Bet v 1 cross-reactions is considered the most prevalent soy allergy in northern and middle Europe, presumably also in North America (Canada, Northern states of the US), depending on the degree of birch pollen exposure. Even in the Japanese adult population with a low prevalence of birch pollen allergy, this type of soy allergy has been observed and is associated with sensitization to Gly m 4 due to cross-reactivity to alder pollen sensitization.¹²²¹ In a recent multicenter study aiming to detect risk factors for systemic reactions induced by labile food allergens, soy milk-induced systemic reactions were found to be strongly associated with hypersensitivity to PR-10 proteins, and independent of PPI ingestion. Other factors related with severe reactions were fasting and ingestion of large amounts of unprocessed foods.³³⁸

- C Massive exposure to unprocessed soybeans could induce IgE-mediated sensitization to hull allergens (Gly m 1, Gly m 2) with subsequent inhalant allergies in exposed (newly or formerly nsLTP-sensitized) individuals.^{1222–1224,1233}

6 – Clinical diagnosis of soy allergy

Specific questions, proper interpretation of sensitization tests (i.e., SPT and IgE), and optional food challenges help establish the diagnosis of soy allergy. The following work-up may facilitate proper diagnosis (Figure 114).

Case history (anamnesis):

Previous reaction(s) to soy, symptoms, affected organ system(s), onset and course (progression), soy-containing food items (high-, mildly-, nonprocessed grade), co-factors (exercise, NSAID, alcohol, etc.), previous reactions after other allergen sources (i.e., peanuts or Bet v 1-related plant foods), additional (allergic) features (i.e., birch pollen allergy, LTP sensitization), and additional atopic diseases (i.e., atopic eczema, asthma). Working hypothesis: Based on soy-related clinical patterns A–C (Table 53).

Skin prick test (SPT):

- Commercial soy extract (reasonable results in case of highly abundant allergens, i.e., seed storage proteins; limited value due to false negative responses in case of cross-reactive labile soy allergen, i.e., Gly m 4 as elicitors).
- Prick-to-prick test with offending soy product (in case of severe anaphylactic reaction, preferably titrated testing with diluted soy product or primary IgE-testing before SPT; potentially false negative, depending on the abundance and stability of the soy allergen in question (i.e., Gly m 4)).
- Prick to prick test with mildly processed soy drinks or soy powder (if Gly m 4 is suspected).

TABLE 53 Features and clinical pattern of three different types of soy allergy

Clinical pattern	A	B	C
Routes of sensitisation	(1) Epicutaneous or intestinal uptake of soybean proteins with subsequent IgE-sensitisation to stable soybean proteins or (2) Epicutaneous or intestinal sensitisation of other legume proteins (i.e. peanut) with subsequent cross-reactivity to i.e. stable soybean proteins	Exposure to Fagales pollen and IgE-sensitisation due to cross reactivity to soybean proteins	
Prevalence (North and Middle Europe)	Low	High	?
Prevalence (Southern Europe)	Low	Low	Occasionally asthma outbreaks in the past
Affected (age) group	(1) Infants/children (2) Adults	Adults/adolescents/Children	Exposed workers and citizens in close vicinity
Soybean allergens involved	Gly m 5, Gly m 6, Gly m 8	(1) Gly m 4 (2) Gly m 3 (presumably)	Gly m 1, Gly m 2
Allergen abundance	Moderate to high content (i.e. seed storage proteins Gly m 5, Gly m 6 and Gly m 8) in soy beans and related products	(1) Low content of Gly m 4 in soy beans and soy protein (0.01–0.1%) and related, less processed soy products; (2) Gly m 3 content not known	Not known
Thermal stability	High	Low	Moderate
Digestive stability	High	Low	Moderate
Elicitors (products)	Many soy products (including highly processed or refined soy products)	Mildly processed soy products (i.e. soy drinks, soy protein powder)	Unprocessed soybeans (i.e. during unloading)
Symptoms	Quick onset (minutes to 2 h) of potentially severe systemic reactions with various symptoms of anaphylaxis: mucosal (i.e. oropharyngeal), cutaneous (urticaria, angioedema, eczema flaring), airway-related (upper and lower airways), gastrointestinal and/or cardiovascular symptoms	Quick onset (2–30 min) mostly mild mucosal symptoms and/or rare systemic symptoms of anaphylaxis	Airway symptoms (i.e. allergic rhinoconjunctivitis and asthma symptoms) within few hours of exposure
Additional clinical features	Atopic eczema (i.e. in infants with soy allergy), sometimes also (potentially severe) reactions after other legumes, (i.e. peanut, lupine, seeds or tree nuts)	Commonly additional (multiple) clinical cross reactivities to other Bet v 1-related plant foods, (i.e. apple, hazelnut, cherry, plum, peach, carrot, celery)	
Medical diagnosis	Risk of systemic allergic reaction to stable soybean proteins (Gly m 5, Gly m 6, and Gly m 8)	Fagales pollen/Bet v 1-related food allergy to cross reactive soy allergen	Allergic asthma and rhinoconjunctivitis due to soy protein inhalation
Avoidance	Advising avoidance of allergenic soy products, in most cases soy sauce and miso can be consumed	Gly m 4 No ingestion of large amounts of mildly processed or unprocessed soy products	Occupational avoidance strategies in situations of large soy protein exposure (unloading of soy shipments)
Product declaration	Mandatory on each soy containing product (EU law)	(Voluntary) additional warning on hardly processed soy products particularly for birch pollen allergic individuals	
Technical solution	No general technical solution available	Thermic or pressure processing of soy to reduce content in labile soy proteins	Dust extractor in occupational settings

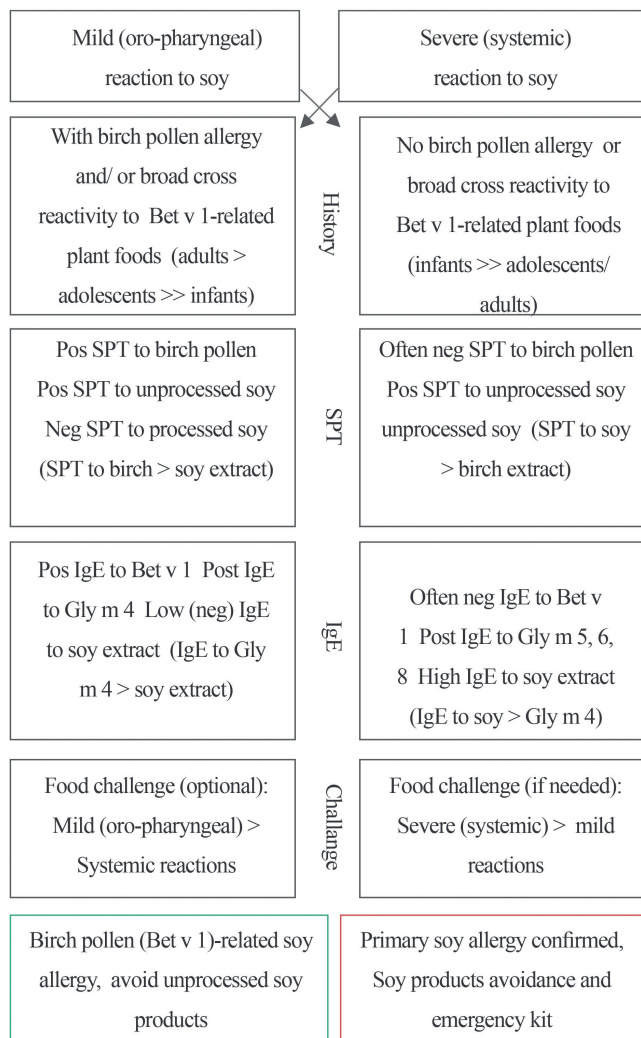


FIGURE 114 Diagnostic work-up in soy-related allergic reactions (representing food allergy class II in left column and class I in right column)

IgE Testing:

Allergen-specific IgE:

- Soy extract,
- Gly m 5, Gly m 6, and Gly m 8
- Gly m 4 and/or Bet v 1.

Comments

- Soy extract-specific IgE is related to oral food challenge outcomes, but 95% positive predictive value (PPV) has not been obtained.^{1216,1660} This test potentially yielded false negative or low titers in the case of clinical pattern B.¹²²¹
- Gly m 5 and Gly m 6-specific IgE are associated with severe allergic reactions to soy.^{1219,1227}
- Gly m 8-specific IgE is the best predictor of soy allergy diagnosis in children¹²²⁹ and adults.

- Gly m 4-specific IgE is a useful diagnostic marker in cases of clinical pattern B.¹²²¹
- Interpretation of SPT and IgE (sensitization tests) outcomes is also shown in [Figure 114](#). The results were clinically relevant only in cases of symptoms corresponding to soy ingestion.

Oral food Challenge tests

In case of a improbable relationship between soy ingestion and allergic reactions:

Depending on the clinical pattern (A – C), a titrated oral food challenge with soy products was performed.

- Offending or another appropriate soy protein-containing product (soy powder, tofu, soy drink).
- Preferably mildly processed soy protein-containing product (soy milk) with soy allergens of low abundance (i.e., Gly m 4).
- If needed, mucosal challenge with titrated soy extracts or offending (unprocessed) soy products.

6 – Clinical management of soy allergy

The advice tailored to specific clinical patterns is indicated below ([Table 53](#)):

- Avoidance of soy-containing products depending on the symptom-eliciting-dose. In case of severe reactions after a small dose, avoidance of small amounts, regardless of the grade of soy processing. In case of a mild reaction after a large dose, less strict avoidance is needed. Fermented soy products such as soy sauce and miso are much less allergenic than tofu and soy milk. Advising complete avoidance of all soy products impairs the quality of life of patients with soybean allergy.
- Avoidance of larger amounts of soy products, particularly those that are hardly or mildly processed (i.e., due to thermal processing, heating, such as soy drinks and powder).
- Avoidance of soy-containing (hull) protein inhalation

Pharmacotherapy for treatment of accidental allergic reactions

The treatment tailored to specific clinical patterns is indicated below:

- Due to the risk of severe reactions after unintentional ingestion of soy-containing products, self-administered emergency medication is required.
- Emergency medication optional (not mandatory) C: Symptomatic treatment as required

Allergen-specific immunotherapy

At present, commercially-available products for allergen-specific immunotherapy of soybean protein allergies are not available.

7 – Clinical cases

Case 1 (clinical pattern¹²²⁹):

History: A boy aged 2 years and 9 months started to develop atopic eczema around his mouth four months after birth. He initially received blood examination at the age of eight months and was already sensitized to egg white, wheat, and soybean (total IgE 250 IU/ml, egg white 21.4 kU/ml, wheat 3.19 kU/ml, and soybean 0.99 kU/ml). He was advised by the doctor to avoid food intake. He was then brought to the hospital at the age of 2 years and 5 months to receive oral food challenges.

In-vitro testing: His laboratory findings at the age of 2 years and 4 months (first visit) were as follows: total IgE, 5650 IU/ml; egg white, 70 kU/ml; wheat, 3 kU/ml; and soybean 17.1 kU/ml (Gly m 8: 37.6 kU/ml, Gly m 5: 4.9 kU/ml, Gly m 6: 1.1 kU/ml).

Diagnosis: He then underwent soy product (tofu) challenge at the age of 2 years and 9 months, and consequently developed skin rash, sneezing, and coughing after ingesting 9 g of tofu.

Recommendations: Avoidance of tofu and soymilk, but not soy sauce, miso, and natto, was advised.

Prognosis: He had naturally outgrown soybean allergy 1 year later with soybean IgE 1.90 kUA/l.

Case 2 (clinical pattern A: Food-dependent exercise-induced anaphylaxis (FDEIA):

History: Girl (16 years old), atopic dermatitis. After 20 minutes of bike riding, anaphylactic reaction (abdominal pain, dyspnea, semi-consciousness, generalized flushing and swelling, low blood pressure), subsequent emergency treatment, and hospitalization for two days occurred. Two similar reactions occurred before the bike riding. No food allergies to soy, peanuts, or other food items are known to date.

SPT: Tofu, soy milk, boiled green soybean, soybean flour weakly positive (half histamine-equivalent), miso, soy sauce, and soybean fibers negative.

In-vitro testing: Total IgE 542 IU/ml, specific IgE to soybean 34 kUA/l, peanut 1.3 kU/l, wheat, Omega-5-Gliadin, various pollens including birch pollen, and Gly m 4 were negative. Microarrayed specific IgE: Gly m 5 (β -conglycinin), Gly m 6 (glycinin), and Gly m 3 were positive; CCD was negative.

Oral challenge: Thirty minutes of exercise after ingestion of 200 g of tofu caused the development of severe urticaria and facial swelling. No reactions occurred after boiling green soybeans or soy milk, with or without exercise.

Diagnosis: FDEIA of the soybean allergen Gly m 5.

Recommendation: Four hours after ingestion of soybean products (particularly tofu), no exercise.

Case 3

History: Male (52 years old), since the age of 42, severe birch pollen-induced rhinoconjunctivitis occurred after ingestion of raw apples, hazelnuts, or strawberry oral itch. Adverse events would occur after subcutaneous immunotherapy (SCIT) with nonmodified birch pollen extract with severe systemic reactions. At the age of 52, after soy dessert, there would be increasing local itch (after 5 min: mouth, palate; after 15 min: eyes) and complete eyelid swelling within 20-30 min, thus requiring emergency treatment and hospitalization overnight. In 2012, after ingesting three fresh apple pieces, local itching (3 min: mouth, palate) and burning sensation of the throat occurred after 15 min. Almost complete eyelid swelling, itchy eyes, stuffy nose would also occur, and after 30 minutes, itchy hives would appear in the upper limbs, needing subsequent emergency treatment.

In-vitro testing: Total IgE was 37 kU/l, specific IgE to Gly m 4: 2.3 kUA/l. In 2012, the Total IgE was 48.5 kU/l, specific IgE to Bet v 1: 24 kUA/l (almost 50% of the total IgE specific for Bet v 1, indicating strong sensitization to Bet v 1 with cross-reactivity to structurally-related allergens).

Diagnosis: Angioedema after soy milk ingestion due to Gly m 4 (Bet v 1-cross reactive soy allergen)

Recommendations: Strict avoidance of mildly processed soy protein products and raw apples is recommended, and great precaution should be taken with large amounts of raw, Bet v 1-cross reactive pome and stone fruits, tree nuts, and legumes. Cooked plant products without dietary restriction (due to thermal instability of Bet v 1-related allergens)

7 – Research and future perspectives

Novel soy allergens other than those approved by the WHO/ IUIS have been reported (<https://allergome.org>). Although the clinical characteristics of these allergens have not been sufficiently examined, further research is expected to improve the accurate diagnosis and understanding of cross-reactivity. The improvement of diagnostic performance by specific IgE testing has been examined. A fusion protein of Gly m 8 and the extension region of the α' subunit of Gly m 5 could potentially diagnose soy allergy in the Japanese pediatric population.¹²³⁴ This technology may be useful for producing novel allergen components with improved diagnostic accuracy. Although allergen immunotherapy for peanuts can have therapeutic effects and improve quality of life, allergen immunotherapy for soy allergy (clinical pattern A) has not been sufficiently examined, thus requiring further research.

B18 – Peanut allergy

Sakura Sato, Kirsten Beyer, Motohiro Ebisawa

Highlights

- IgE to peanut components is a valuable tool for the clinician to diagnose and manage peanut allergy in children and adults. Tests for specific IgE to some peanut allergen components are commercially available, such as Ara h 1, 2, 3, 6, 8, and 9.
- Knowing which allergen the patient is sensitized to can help to predict the severity of allergic reaction and prognosis. Sensitization to storage proteins, which has high stability, (e.g., Ara h 2 and Ara h 6) is associated with severe allergic reaction, whereas labile proteins are less likely to cause severe reactions.

1 – The allergen sources

The peanut (*Arachis hypogaea*) belongs to the legume family (Leguminosae). Peanuts are most commonly grown in China, followed by India and the United States of America (USA). There are many different known cultivars. Peanuts are a common trigger of food-induced anaphylaxis. In some parts of the world, such as Europe or the USA, peanuts are primarily consumed in its roasted form. They might be eaten as whole peanuts, peanut butter, peanut flips, or as an ingredient in various products. Peanuts can be roasted in the shell and sold as such, or they can be shelled, blanched, oven-roasted either dry or in oil, and ground for the production of peanut butter or be sprayed on peanut flips. In other parts of the world, such as Asia and Africa, raw peanuts are used more commonly as a cooking ingredient.

Peanuts have a high protein content of 24–29% and contain various allergens. The processing of peanuts seems to be important regarding their allergenicity as roasting at high temperatures likely promotes the formation of compact globular protein aggregates that can increase the allergenicity of Ara h 1 and 2 as well as the oleosins, whereas cooking might reduce their allergenicity. In addition, peanut oil is commonly used, and its refined form can be safely consumed by most peanut-allergic individuals, whereas unrefined oil can contain amounts of allergens sufficient enough to trigger allergic reactions in some of the same individuals.

2 – Allergen families

A number of peanut allergens have been identified. Many of them have protective functions or are seed storage proteins. Peanut allergens belong to diverse protein families as prolamins, cupins, profilin, Bet v 1-like pathogenesis-related (PR)-10 proteins, lipid transfer proteins (LTPs), defensins, and oleosins (Table 54). Recently, a protein that belongs to the cyclophilin family was identified.¹⁶⁶¹ Peanut proteins lead to IgE-mediated cross-reactions

among different members of the legume family as do other plant foods, such as tree nuts.

3 – Allergenic molecules

Seventeen peanut proteins most commonly involved in allergic reactions to peanut have been identified and officially accepted by the World Health Organization (WHO)/International Union of Immunological Societies (IUIS) Allergen Nomenclature Sub-Committee (Table 54, Figure 115). Ara h 1, Ara h 2, and Ara h 3 are considered peanut storage proteins and have high heat stability and digestive resistance. These allergens have been designated as major allergens, which were found to induce the greatest prevalence of IgE reactivity among allergic patients. Ara h 6 and Ara h 7 are also considered peanut storage proteins. Ara h 6 shares a part of IgE epitopes with Ara h 2 and is cross-reactive to Ara h 2.¹⁹¹ Ara h 5 is a minor allergen and is homologous with pollen profilins. Ara h 8, a PR-10 protein, has been shown to be a major allergen for patients with combined birch pollen and peanut allergies. Lipid transfer protein (LTP), a pan-allergen with a degree of cross-reactivity comparable to profilin, is present in peanuts as Ara h 9, Ara h 16, and Ara h 17. Ara h 10, Ara h 11, Ara h 14, and Ara h 15 belong to the peanut lipophilic allergen group, oleosin. Defensins are presented in the complex peanut lipophilic matrix as Ara h 12 and Ara h 13. Ara h 18 was recently identified and belongs to the cyclophilin family¹⁶⁶⁶.

4 – Sensitization to individual molecules and their clinical relevance

Sensitization rates are mainly based on the skin prick test (SPT) or specific IgE measurements with regard to whole peanut extracts. The sensitization rates vary widely depending on the age, comorbidities and other inhalant allergies of the tested population. Clinically not relevant sensitization seems to be especially high in patients with a coexisting pollen allergy, whereas clinically relevant sensitization is much higher in children with eczema. In an Australian study, it has been shown that infants with eczema are 8 times more likely to develop a peanut sensitization and 11 times more likely to have a peanut allergy than infants without eczema.¹⁶⁶² Screening a nonselected cohort of 13,100 German children of the general population aged 3–17 years demonstrated that almost 11% of the children were sensitized to peanuts¹⁶⁶³. The study of EuroPrevall on the prevalence of sensitizations to foods in adults revealed that peanut extract sensitization rates differed between 0.5– 7.2% and that the region with the greatest prevalence of those with a peanut sensitization Madrid.¹¹⁴⁶ The prevalence of peanut sensitization predominantly results from a cross-reactivity to pollen and does not reflect the rate of peanut allergy. The majority of the peanut-allergic patients are sensitized to Ara h 2, whereas sensitization to Ara h 2 was lower in children of the general population.¹²³¹ Geographical differences were observed in sensitization rates to Ara h 8 and Ara h 9, which

TABLE 54 Peanut allergens (Only allergens approved by WHO/IUIS Allergen Nomenclature Sub-Committee; www.allergen.org, 08-09-2021)

Allergen	Protein family	Other names	Molecular weight (kDa)	Heat stability
Ara h 1	Vicillin	7S globulin	64	Yes
Ara h 2	2S albumin	Conglutin	17	Yes
Ara h 3	Legumin	Glycinin, 11S globulin	60, 37 (fragment)*	Yes
Ara h 4	Renamed to Ara h 3.02, number not available for future submissions			
Ara h 5	Profilin		15	No
Ara h 6	2S albumin	Conglutin	15	Yes
Ara h 7	2S albumin	Conglutin	15	Yes
Ara h 8	Bet v 1	Pathogenesis-related protein	17	No
Ara h 9	Non-specific lipid-transfer protein type 1	(PR) -10	9.8	Yes
Ara h 10	Oleosin		16	Yes
Ara h 11	Oleosin		14	Yes
Ara h 12	Defensin		8 (reducing)*, 12 (non-reducing)*, 5.184 (mass)*	To be expected
Ara h 13	Defensin		8 (reducing)*, 11 (non-reducing)*, 5.472 (mass)*	To be expected
Ara h 14	Oleosin		17.5	Yes
Ara h 15	Oleosin		17	Yes
Ara h 16	Non-specific lipid transfer protein 2		8.5	Yes
Ara h 17	Non-specific lipid transfer protein 1		11	Yes
Ara h 18	Cyclophilin - peptidyl-prolyl cis-trans isomerase		21	???

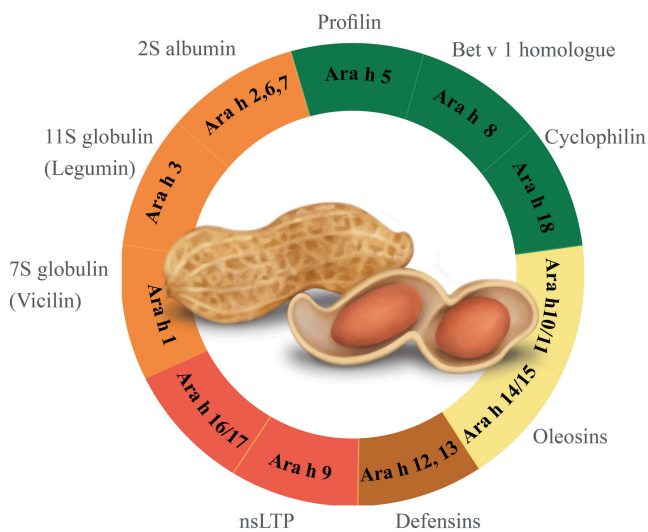


FIGURE 115 Identified peanut allergens

were found to be major allergens for Western/Central and Southern Europeans.¹²³⁵

In patients with clinically relevant peanut allergy, it had been shown that 76–96% of peanut-allergic children and adolescents in the US and

Central and Northern Europe possess specific IgEs that respond to Ara h 2 and Ara h 6, compared with only 42% in Spain.¹⁶⁶⁴ The sensitization rates for Ara h 1 are between 63% and 80%. Those for Ara h 3 are somehow lower, while the rate for Ara h 7 is only 43%. Ara h 9 is considered a secondary food allergen, particularly in Mediterranean countries.¹⁶⁶⁵ This secondary sensitization/ cross-reaction is likely due to other on-specific lipid transfer proteins (nsLTPs) (e.g., Pru p 3 in peach). Sensitizations to the Bet v 1-homologous PR-10 protein Ara h 8, the profilin Ara h 5, and glycoproteins (CCD) are usually caused by cross-reactions to pollen allergens. Sensitization rates vary depending on regional pollen exposure and on eating habits. The prevalence of sensitization to Ara h 10/11 and Ara h 14/15 is similar to that of Ara h 2 in a German cohort but still has to be investigated in larger groups of patients.¹²⁴¹ The fact that oleosins may be underrepresented or absent in aqueous peanut extracts represents a diagnostic gap hampering the identification of affected patients.¹²³⁶

5 – Clinical patterns of peanut allergy

Three distinct scenarios can prompt sensitizations and potential clinical symptoms depending on the different routes of exposure and physicochemical properties of the involved peanut proteins:

- A The sensitization to seed storage proteins (i.e., Ara h 1, 2, 3, 6, and 7), which are considered allergens predominately in children with peanut allergies. Infants and young children with eczema are sensitized predominantly to seed storage proteins, while sensitization to pollen-related food allergens seems to be rare. Patients frequently react with immediate-type symptoms involving the skin (e.g., urticaria), the gastrointestinal tract (e.g., vomiting), the respiratory system (e.g., wheezing) and/or the cardiovascular system (e.g., drop in blood pressure). Ara h 2 and Ara h 6 are associated with a severe allergic reaction to peanut. This hazard is likely linked to the high stability of the allergens and their high proportion of the total protein content (Figure 116).
- B The sensitizations to the Bet v 1-homologous PR-10 protein Ara h 8, the profilin Ara h 5, and CCD are usually caused by sensitization to pollen allergens. Birch pollen allergy is responsible for a considerable north-south gradient in Europe in terms of cross-reactions to Ara h 8; in regions of higher grass pollen exposure, increased cross-reactive IgE to Ara h 5 and CCD-containing peanut extracts can be expected. The involved proteins are largely labile to heat and digestion. Since peanuts are generally consumed roasted or cooked and not raw, mostly no or only mild and predominantly oropharyngeal symptoms develop, depending on the amount of allergen consumed.
- C Ara h 9 is considered a secondary food allergen, particularly in Mediterranean countries. This secondary sensitization/cross-reaction is likely due to other nsLTP (e.g., Pru p 3 in peach).¹²³⁷ Since Ara h 9 possesses thermal and digestive stability, affected patients can develop systemic symptoms.¹¹⁵⁷

6 – Clinical diagnosis of peanut allergy

Specific questions, the proper interpretation of sensitization tests (i.e., SPT, IgE) and, if necessary, oral food challenges help to establish the diagnosis of peanut allergy.

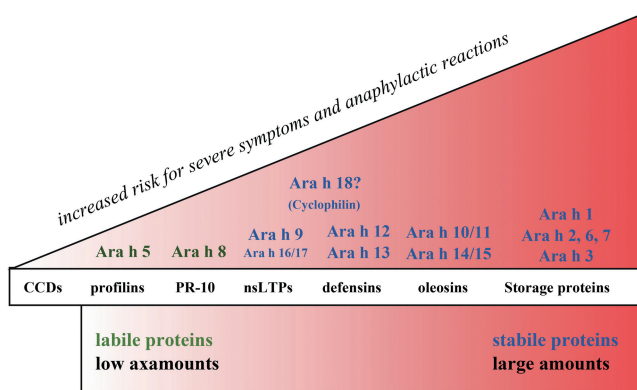


FIGURE 116 Risk ramp for peanut allergens: increased risk for severe symptoms and anaphylactic reactions from left to right

Case history (anamnesis):

The patient is asked for her/his experiences with the following: previous reaction(s) to peanuts, symptoms, affected organ system(s), the onset and course (progression), co-factors (e.g., exercise, acute infection, emotional stress, disruption of routine, premenstrual status, medications, alcohol intake,), previous reactions to other allergen sources (i.e., peach), additional (allergic) features (i.e., birch pollen allergy), additional atopic diseases (i.e., atopic eczema, asthma).

Working hypothesis: based on peanut-related clinical patterns A–C.

SPT:

- Commercial peanut extract (reasonable results in case of highly abundant allergens; i.e., seed storage proteins)
- Prick-to-prick test with peanuts or offending peanut product (in case of severe anaphylactic reaction: primary IgE testing before SPT)

IgE Testing:

Allergen-specific IgE:

- Peanut extract
- Ara h 2 and Ara h 6
- Ara h 8 and/or Bet v 1
- Ara h 9 and/or an LTP-representative (i.e., Pru p 3)

Comments:

- Ara h 2-specific IgE demonstrates the best diagnostic accuracy of peanut allergy in infants, children, and adults. Ara h 2-specific IgE at 0.35 kU/L is a useful cut-off value in the diagnostic approach for peanut allergy in children based on a systematic review and meta-analysis.¹⁶⁶⁶
- To predict a positive peanut challenge with 95% probability, the Ara h 2-specific IgE level has to exceed of 42 kU/L. To predict a negative peanut challenge with 90% probability, the Ara h 2-specific IgE level has to be <0.03 kU/L, with some discordant exceptions in German children based on a previous study¹⁵⁰ (Figure 117A,B).
- An absolute (100%) prediction cannot be achieved with measurements of Ara h 2-specific IgE due to exceptions to the preceding. Subsequently, the individual clinical relevance of allergen-specific IgE concentrations (i.e., to single allergens of legumes) has to be determined on a case-by-case basis by the physician in charge.
- As shown above, Ara h 2 has the greatest specificity; however, it has a lower sensitivity than do SPT and peanut-specific IgE. In a patient with a high prior probability, the clinician may use not only Ara h 2 but also SPT or peanut-specific IgE to confirm the diagnosis of peanut allergy.¹²³⁸

Stepwise approach. The measurements of peanut-specific IgE and/or SPT are good screening parameters in patients at risk for peanut allergy. The absence of peanut-specific IgE has a high negative

predictive value. Positive peanut-specific IgE and/or SPT are only clinically relevant in the presence of corresponding symptoms.

In cases wherein the presence or absence of allergic reactions due to peanut consumption is not known, if the screening is positive, Ara h 2-specific IgE should be measured. Measurements of peanut- and Ara h 2-specific IgE play an essential role in case of suspected primary peanut allergy. A clear history of objective immediate allergic reactions to peanut and elevated Ara h 2-specific IgE are highly suggestive of a clinically relevant peanut allergy (Figure 118). An oral food challenge is often not needed. In patients with uncertain history of immediate reaction following peanut consumption, physicians can

proceed with the current diagnosis of peanut allergy according to (Figure 119). Peanut-specific IgE is sometimes detectable in children with severe atopic dermatitis and in the population. Therefore, unexpected findings of elevated IgE to peanuts are often seen in clinical practice. A stepwise approach takes the potential consequences into consideration. The most important initial question is related to the frequency (e.g., more than once a month) and time course (e.g., within the previous six weeks) of peanut consumption.

In general, the measurement of Ara h 1- and 3-specific IgE is often not necessary since mono-sensitizations to Ara h 1 and/or 3 are rare. In doubt, an oral food challenge test can clarify cases of a

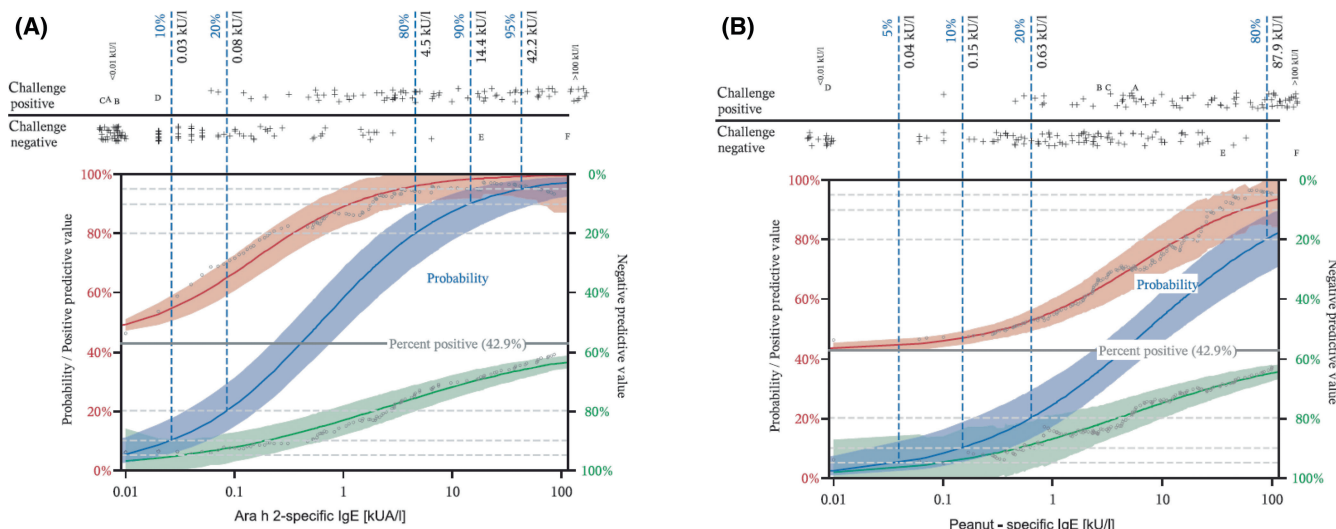


FIGURE 117 Study results regarding the risk of peanut allergy associated with allergen-specific IgE to the 2S-albumin seed storage protein Ara h 2 (A) compared with whole peanut extract (B)

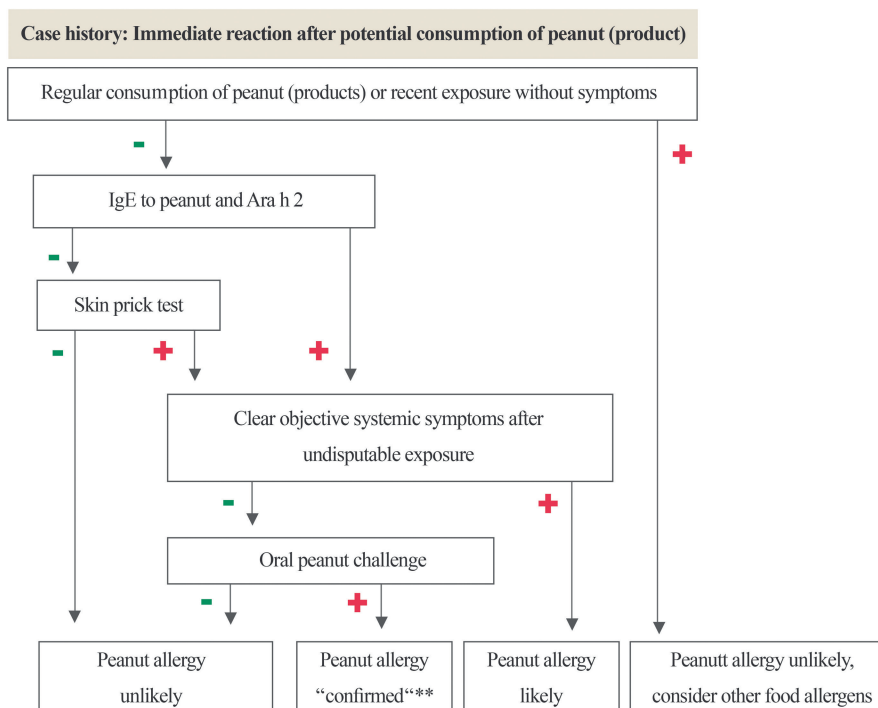


FIGURE 118 Diagnostic algorithm for peanut allergy in clinical setting: Clear history of immediate reaction to peanut

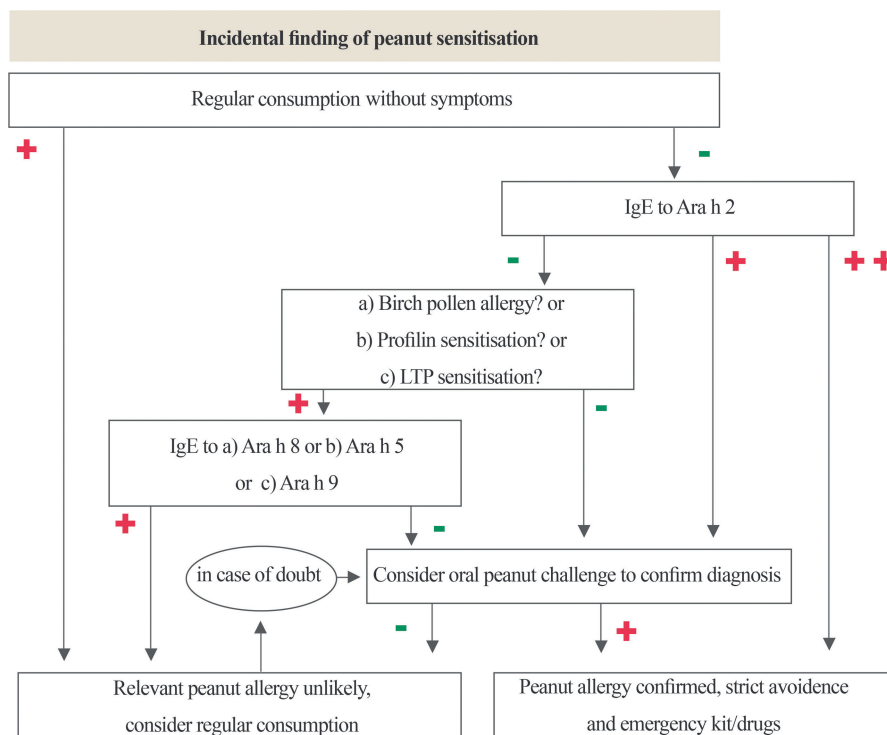


FIGURE 119 Diagnostic algorithm for peanut allergy in clinical setting: Uncertain peanut allergy history

negative or low IgE response to Ara h 2. If there is no specific IgE to any seed storage protein, a clinically relevant peanut allergy is unlikely, although it cannot be ruled out completely in the presence of sufficient clinical suspicion (diagnostic gap due to factors such as the lipophilic oleosins Ara h 10/11 and Ara h 14/15 missing in aqueous diagnostic extracts). Specific IgE to nsLTP Ara h 9 should be additionally determined in patients from the Mediterranean region. In patients with a typical clinical history of pollen food syndrome, specific IgE to PR-10 Ara h 8 and/or birch pollen measurement is considered (Figure 119).

Oral food challenge tests

(In case of doubtful relationship between peanut ingestion and allergic reaction (see stepwise approach (Figures 118 and 119)): Depending on the patient history of titrated oral food challenges with peanuts (e.g., whole peanuts or lightly roasted peanut flour).

6 – Clinical management of peanut allergy

Advice and avoidance

Strict avoidance of all peanut-containing products is recommended. Peanuts are required to be labeled in all prepacked and non-prepacked food items. A great problem still exists with “may contain” labels. sensitization to tree nuts is often experienced by patients with peanut allergy, and avoidance of all species is commonly advised in case of suspicion of allergy to peanut or tree nut. However, except for patients with concomitant tree nut allergies, several tree nuts could potentially be ingested.¹²³⁹

Pharmacotherapy for treatment of accidental allergic reactions

Due to the risk of severe reactions after the unintentional ingestion of peanut-containing products, adrenaline for self-administration should always be on-hand.

Allergen-specific immunotherapy

Commercial products for the allergen-specific immunotherapy for peanut allergy are available. The European Academy of Allergy and Clinical Immunology Guidelines on allergen¹²⁴⁰ immunotherapy state,²⁹⁵ “Oral immunotherapy is recommended as a treatment option to increase the threshold of reaction during treatment in children with peanut allergy from approximately four to five years of age.” However, it should only be undertaken in highly specialized clinical centers with expertise and facilities to safely deliver this therapy.

7 – Clinical cases

Case 1:

History: Boy, two years of age. He ate a peanut snack at a friend's house. He had never eaten peanut products prior to that incidence. After 30 minutes, he developed urticaria and coughing and after 40 minutes, wheezing (Figure 118).

In vitro testing: Peanut-specific IgE 5.2 kUA/L, Ara h 2-specific IgE 3.1 kUA/L.

Diagnosis: Peanut allergy

Oral food challenge: An oral food challenge was not necessary for the diagnosis.

Recommendation: Peanut avoidance, education from dietitian, emergency medication (including adrenaline autoinjector).

Case 2:

History: Girl, 5 years of age with hen's egg allergy. She developed urticaria after accidental ingestion to cake included egg and peanut. At the time of writing, she had never eaten peanuts or peanut products.

In vitro testing: Peanut-specific IgE 62.8 kU/L, Ara h 2-specific IgE 48.0 kU/L.

Oral challenge: A titrated peanut challenge was not recommended as the predicted probability for peanut allergy was 95% (Figure 117A,B).

Diagnosis: Peanut allergy likely (highly suggestive).
Recommendation: Peanut avoidance, education from dietitian, emergency medication (including adrenaline autoinjector).

Case 3:

History: Boy, 14 years of age with allergic rhinoconjunctivitis during the spring. On a panel test, he showed sensitization to birch pollen and peanut. He had eaten peanuts in the past without allergic reactions, though his consumption was infrequent (Figure 119).

In vitro testing: Birch-specific IgE >100 kUA/L, peanut-specific IgE 20.1 kUA/L, Ara h 2-specific IgE 0.1 kUA/L. Oral challenge: An oral food challenge was not necessary for the diagnosis.

Diagnosis: Allergic rhinoconjunctivitis, relevant peanut allergy unlikely.

Recommendation: Consider regular consumption.

8 – Research and Future Perspectives

Unknown allergens other than those approved by WHO/ IUIS Allergen Nomenclature Sub-Committee might be still hidden in peanut proteins, especially the complex lipophilic matrix. To make a more accurate diagnosis and improve our understanding of cross-reactivity, these allergens related to clinical characteristics need to be examined. In addition, several studies have reported that IgE-binding epitopes may become a biomarker for characterizing numerous phenotypes of peanut allergy.^{140,1241} Further research may be expected to determine a biomarker for the prediction of the prognosis and more effective products for allergen-immunotherapy.

B19 – Tree nut and seed allergies

Anna M. Ehlers, Helen A. Brough, Gideon Lack,
Edward F. Knol, Magnus Wickman, Suzana Rudolovic

Highlights

- Sensitization to Bet v 1 homologues such as Cor a 1 and Jug r 5 occurs mainly in the adult population of the Northern hemisphere (birch pollen pandemic area) and it often results in no or mild symptoms.
- Sensitization to nsLTPs with peach Pru p 3 as a primary sensitizer occurs mainly in the Mediterranean area.
- Sensitization to hazelnut 2S albumin Cor a 14 is associated with severe allergic reactions and such associations may also be present for 2S albumins of other tree nuts and seeds (e.g., Jug r 1, Ana o 3, Ses i 1).
- Co-sensitization and *in vitro* cross-reactivity are often not clinically relevant, but *in vivo* cross-reactivity can occur.
- While clinically relevant sensitization to pistachio and pecan nut usually implies clinically relevant sensitization to cashew nut and walnut, respectively, the reverse does not always occur.

1 – Background

Tree nuts and seeds, but also legumes are in fact all seeds and allergens in these foods, are often shared. Such allergenic proteins belong to the families of storage proteins (2S albumins, vicillins or 7S globulins and legumins or 11S globulins), lipid transfer proteins (LTPs), pathogenesis-related (PR) 10 proteins (Bet v 1-homologues), profilins and oil-body associated oleosins. The degree of sequence homology of the same protein family between tree nuts and between seeds is largely dependent on the botanical relationship. Most allergic reactions are caused by consumption of tree nuts and seeds by individuals allergic to these foods. Severity of reactions varies from mild/moderate to severe or life-threatening and, although rarely, they can have fatal outcome.^{1242,1243} Some nuts and seeds were uncommon in the Western diet, a variety of tree nuts and seeds have become increasingly popular over the past decades due to their favourable nutritional profile. Nuts and seeds are often eaten as single food items, such as snacks, or as ingredients in healthy foods and salads. As dietary practices have changed, dishes traditional to certain parts of the World are now commonly eaten worldwide. Dishes such as ragouts, Middle (e.g., hummus, tagine), Far Eastern (e.g., stir fry with cashew nuts, pad Thai) and Indian sub-continent dishes (e.g., curry, korma) and pastries, cakes, chocolate, and candies often contain seeds or various tree nuts as substantial ingredients (Figure 120).

The current pattern of increased exposure to and consumption of nuts and seeds is a potential explanation for the suggested increase in reported reactions to such food items in addition to the general increase in incidence of food allergies. This includes foods

such as flaxseed that appears as an emerging allergen¹²⁴⁴ and chia seeds.¹²⁴⁵ In this chapter, we will discuss allergens of hazelnut, almond, cashew/pistachio, walnut/pecan nut, and Brazil nut, as well as to a lesser extent allergens of macadamia, pine nut, and the seeds sesame, sunflower, pumpkin, poppy, mustard, flaxseed, chia seeds and buckwheat. Coconut is not considered as a tree nut in Europe; however, the approach in the United States of America is different. Although American College of Asthma, Allergy & Immunology does not recognise coconut as a tree nut,¹²⁴⁶ it is still a legal requirement to declare coconut as one of the tree nut allergens (Food and Drug Administration).

2 – Allergen sources

In Europe, Canada and the United States, tree nuts, peanuts and seeds are listed as priority food allergens. Tree nuts and seeds are found in many food products, as shown in (Figure 120). Today, many food items are also labelled with precautionary allergen labelling (PAL), for instance “may contain nuts/peanuts/seeds,” which should provide consumers with information on unintentional presence of allergens caused by cross-contamination in food preparation and packaging. However, there is currently no explicit guidelines for PAL and food products are mostly labelled without proper risk assessment. This often causes substantial problems for tree nut or seed allergic individuals and leads to misinterpretation of labels. This practice is expected to change as a new guideline is in preparation by the European Union and its Member States (EUMS) in cooperation with Australia, United Kingdom and the United States of America (progress can be seen at https://ec.europa.eu/info/law/better-regulation/have-your-say/initiatives/12230-Food-safety-allergies-&-food-waste-new-EU-rules_en).¹²⁴⁷

Allergic reactions have been described after exposure to all food items containing nuts or seeds. Oil made from these nuts and seeds have been found to contain potential allergenic proteins. However, the concentrations of these proteins are very low in refined oils and do not trigger allergic reactions in majority of allergic individuals.¹²⁴⁸ As most of tree nuts and seeds allergens, except for profilin and pathogenesis-related 10 (PR-10) allergens, are heat stable, processing does not have a great impact on the allergenicity of such food products.

3 – Major and relevant minor allergenic proteins of tree nuts and seeds

An overview of allergenic proteins from tree nuts and seeds is depicted in Tables 55 and 56. Tree nut allergens belong to a limited number of protein families. One important protein family comprises seed storage proteins (discussed in Chapter C08). Those proteins are known for their resistance to digestion and their heat stability. The most resistant family members are the 2S albumins with a molecular mass ranging from 10 to 16 kDa. Recent findings indicate that

Food and products that contain or often contain tree nuts and seeds

Chocolate and pralines
 Nougat (sugar paste made with nuts), for example, Torrone
 Dishes such as almond chicken, pad thai, chili and trout amandine
 Gianduja and giandula (chocolate blended with hazel nuts)
 Marzipan (almond paste)
 Almond milk
 Nut milk
 Tree nut oils
 Spreads, for example, almond paste-based spreads, cheese spreads, chocolate nut spreads
 Nutella (hazelnut)
 Tahini, halva (sesame)
 Vegetarian dishes
 Various Indian curries and Asian dishes
 Industrial made Pesto
 Industrial made tomato sauce with cheese
 Industrial made pasta dishes
 Cereals

Other possible sources of tree nuts

Baked goods
 Baking mixes, cereals, crackers and muesli
 Barbecue and pesto sauces
 Dressings and gravies
 Flavoured coffees
 Frozen desserts
 Liqueurs, for example, amaretto, Frangelico
 Natural flavourings and extracts, for example, pure almond extract
 Salads, for example, Waldorf salad
 Snack foods, for example, trail mix

Non-food sources of tree nuts

Bean bags, kick sacks/hacky sacks
 Bird seed
 Cosmetics, hair care products, sun screens
 Massage oils
 Pet food

FIGURE 120 Foods and ingredients containing tree nuts, and seeds. Note: These lists are not complete and may change. Food and food products purchased from other countries, through mail-order or the internet, are not always produced using the same manufacturing old labeling standards as in Europe.

sensitization to 2S albumins, such as sensitization to hazelnut Cor a 14, might be related to rather severe allergic reactions.⁴³

Other prominent members of this family are 11S (legumins) and 7S globulins (vicilins), which have a molecular mass of around 50 and 70 kDa, respectively, and they form hexameric and trimeric aggregates, respectively. In children, sensitization to the hazelnut 11S globulin Cor a 9 has also been associated with the risk of an allergic response comparable to sensitization to the hazelnut 2S albumin Cor a 14.¹²⁴⁹

Pathogenesis-related (PR) proteins form an additional group of well-known tree nut and seed allergens: PR-10 proteins with a high homology to the major birch pollen allergen Bet v 1 and PR-14 proteins so-called nonspecific lipid transfer proteins (nsLTP). The most intensively studied Bet v 1 homologue in tree nuts is hazelnut Cor a 1 and sensitization to this allergen accounts for up to 90% of sensitization to hazelnut in Central and Northern Europe⁴⁴ [10]. Similarly, sensitization to walnut Jug r 5 was found in up to 90% of walnut allergic patients in the birch-pandemic area and sensitization to Jug r 5 correlated strongly with sensitization to Bet v 1.⁴⁶ By contrast, nonspecific LTPs are important allergens in the Mediterranean area, which has been described for hazelnut (Cor a 8), walnut (Jug r 3) and almond (Pru du 3). The primary sensitizer within the nsLTPs family is thought to be the peach nsLTPs Pru p 3. In the Northern hemisphere also the LTP from mugwort Art v 3 appears to play a role as primary sensitizer.¹²⁵⁰

Not yet well characterized allergens are lipophilic proteins, which belong to the group of oleosins (discussed in Chapter C-10). Specific IgE binding to this group has been shown in a subpopulation

of hazelnut allergic patients across Europe, but its clinical relevance has not yet been fully proven.

In tree nuts, most allergens have been described for hazelnut, which is most probably the direct result of more research for this food. For the seed allergens, the same protein families have been described like for tree nuts, with 2S albumins and 7S and 11S globulins as the most frequently described allergens. Consideration should be given to the fact that the absence of identified allergens in seeds belonging to certain protein families might be explained by the lack of research with many allergens still needing to be discovered.

4 – Sensitization to individual molecules and their clinical relevance

It is challenging to establish an overall prevalence of sensitization to tree nuts and seeds, particularly to an individual tree nut or seed allergen. The prevalence differs in different parts of the world and, except for sesame, allergy to seeds is quite rare in most of the countries. Studies investigating prevalence of tree nuts/seeds sensitization vary in their methodology. Some studies define sensitization rates irrespective of sensitization to birch pollen, and other studies excluded individuals sensitized to birch pollen. This is important to note because sensitization to the pathogenesis-related 10 (PR-10) protein in birch pollen, Bet v 1, can lead to *in vitro* cross-reactivity with homologous proteins (e.g., Cor a 1),

TABLE 55 Identified tree nut allergens. Overview of the different tree nut allergens divided by protein family

Source	Seed storage proteins			Pathogenesis-related proteins		Profilins	Oleosins	Others
	2S albumins	7S globulins	11S globulins	PR-10 proteins Bet v 1-homologue	PR-14 proteins nsLTPs			
Hazelnut <i>Corylus avellana</i>	Cor a 14	Cor a 11	Cor a 9	Cor a 1	Cor a 8	Cor a 2	Cor a 12 Cor a 13 Cor a 15	
Almond <i>Prunus dulcis</i>	Pru du 2S albumin Pru du AP ^a	Pru du 8 ³	Pru du 6	Pru du 1	Pru du 3	Pru du 4		Pru du 2 ¹ Pru du 5 ² Pis v 4 ⁵
Cashew nut <i>Anacardium occidentale</i>	Ana o 3	Ana o 1	Ana o 2					
Pistachio <i>Pistacia vera</i>	Pis v 1	Pis v 3	Pis v 2 Pis v 5					
Walnut <i>Juglans regia</i>	Jug r 1	Jug r 2 Jug r 6	Jug r 4	Jug r 5	Jug r 3 Jug r 8	Jug r 7		
Pecan nut <i>Carya illinoensis</i>	Car i 1	Car i 2	Car i 4					
Brazil nut <i>Bertholletia excelsa</i>	Ber e 1		Ber e 2					
Macadamia nut <i>Macadamia integrifolia</i>			Mac i 2		MiAMP2a			
Pine nut <i>Pinus pinea</i>	Pin p 1	Pin p vi-cilin						Pin p 17 kDa ⁶
Coconut <i>Cocos nucifera</i>		Coc n 1 Coc n 2	Coc n 4			Con n 5		

"Bold font indicates the availability on commercial diagnostic platforms; nsLTP: non-specific lipid transfer protein, PR10: pathogenesis-related protein 10; 1: Thaumatin, 2: Ribosomal protein P2, 3: Antimicrobial seed storage protein, 4: conglutin, 5: Mn superoxide dismutase, 6: not known yet"

Bold font indicates the availability on commercial diagnostic platforms; nsLTP: non-specific lipid transfer protein, PR10: pathogenesis-related protein 10; 1: Thaumatin, 2: Ribosomal protein P2, 3: Antimicrobial seed storage protein, 4: conglutin, 5: Mn superoxide dismutase, 6: not known yet

which accounts for a substantial part of sensitization to tree nuts and seeds. Those IgE cross-reactivities are mostly clinically irrelevant or cause only mild reactions to particular foods while sensitization to seed storage proteins is less common but can cause severe allergic reactions.

The EuroPrevall study reported significant differences in rates of sensitization to tree nuts in children between different study centres across Europe, with hazelnut sensitization rates varying from 1.87% in Reykjavik to 8.63% in Madrid and 9.52% in Utrecht and to 14.35% in Zurich (Table 57). Similar pattern was observed in terms of walnut sensitization with 1.37% in Reykjavik, 7.45% in Madrid and 9.52% in Zurich. Amongst seeds, sesame sensitization was the most common across most of the centres, with the lowest rates in Reykjavik at 2.86% and Vilnius at 3.03% and higher rates in Madrid (11.90%) and Zurich (12.10%). In Madrid, for example, sesame was one of the three foods to which sensitization was most common. Nevertheless, the patterns of probable food allergy were different. Probable food allergy (defined as sIgE and reported hypersensitivity-related

symptoms within 2 hours after ingestion) to hazelnut was the most observed in Vilnius at 2.15%, followed by Zurich at 0.81%. Probable food allergy to walnut was the most reported in Athens (0.56%). The rates of probable food allergy to seeds were <0.01% for most centres.¹⁰²⁸ Results published by EuroPrevall-INCO Study Team in China, India, and Russia also showed variations in the prevalence of IgE sensitization (defined as specific IgE >0.7 kU/L) and probable allergy to tree nuts and seeds in children in the three participating countries. Interestingly, despite quite high rates of sensitization to nuts and seeds, particularly in India, rates of probable allergy are low.¹²⁵¹

Sensitization patterns also differ between EuroPrevall study centres in the adult population using the same methodology (Table 58). Whilst the rate of probable allergy to hazelnut was quite low in Athens, at 0.06%, it reached 2.57% in Zurich. Probable allergy to walnut was the most reported in Madrid (0.71%) and Zurich (0.58%) and the least commonly in Reykjavik (0.05%). Despite low rate of probable allergy in Athens at 0.29%, walnut was one of the

TABLE 56 Identified seed allergens. Overview of the different seed allergens divided by protein family

Source	Seed storage proteins			Pathogenesis-related proteins		Profilins	Oleosins	Others
	2S albumins	7S globulins	11S globulins	PR-10 proteins Bet v 1-homologue	PR-14 proteins nsLTPs			
Sesame	Ses i 1	Ses i 3	Ses i 6			Ses i 8	Ses i 4	
<i>Sesamum indicum</i>	Ses i 2		Ses i 7			Sin a 4	Ses i 5	
Mustard seed	Sin a 1		Sin a 2		Sin a 3			
<i>Sinapis alba</i>								
Sunflower seed	Hel a 2S				Hel a 3	Hel a 2		Hel a 4 ^a
<i>Helianthus annuus</i>	albumin							
Pumpkin seed	Cuc ma 5		Cuc ma 4			Cuc ma 2		
<i>Cucurbita maxima</i>								
Poppy seed				Pap s 1		Pap s 2		Pap s
<i>Papaver somniferum</i>								34kDa ^a
Buckwheat	Fag e 2	Fag e 3 Fag	Fag e 1 ^a					Fag e 10
<i>Fagopyrum esculentum</i>		e 4 Fag e 5						Fag e 11 ^b
Flaxseed	Lin u 1							
<i>Linum usitatissimum</i>								

Bold font indicates the availability on commercial diagnostic platforms; nsLTP: non-specific lipid transfer protein, PR10: pathogenesis-related protein 10; 1: Defensin, 2: Alpha-amylase inhibitor, 3: Trypsin inhibitor, 4: 13S globulin, legumin-like protein, 5: not known yet. Chia seed not available.

TABLE 57 Prevalence of food sensitization in comparison to probable food allergy in children across Europe

	Zurich	Madrid	Athens	Utrecht	Vilnius	Lodz	Reykjavik	Hong Kong	Guangzhou	Shaoguan	Tomsk	India
Hazelnut	14.35 0.81	8.63 0.53	3.63 0.28	9.52 0.74	6.82 2.15	7.56 0.78	1.87 0.07	1.6 <0.01	<0.01	2.0 <0.01	3.2 0.05	3.8 <0.01
Walnut	9.52 0.27	7.45 0.53	5.33 0.56	3.55 0.53	2.28 <0.01	3.58 0.48	1.37 <0.01	1.0 <0.01	<0.01	2.1 <0.01	0.7 0.03	4.2 <0.01
Sesame	12.10 <0.01	11.90 <0.01	5.82 <0.01	6.50 <0.01	3.03 <0.01	5.50 <0.01	2.86 0.15	2.2 -	<0.01	3.3 -	2.3 -	8.0 -
Mustard	4.92 <0.01	3.33 <0.01	2.18 <0.01	1.72 <0.01	3.04 <0.01	2.48 <0.01	0.37 <0.01	0.1 -	<0.01	1.0 -	0.9 -	3.3 -
Sunflower	8.89 <0.01	6.16 0.53	4.85 <0.01	4.67 <0.01	3.41 <0.01	4.54 <0.01	1.37 <0.01	1.6 <0.01	<0.01	2.0 <0.01	1.0 0.03	5.5 <0.01
Poppy seed	8.50 <0.01	6.32 <0.01	3.15 <0.01	4.88 <0.01	2.28 <0.01	3.99 <0.01	0.75 <0.01	0.1 -	<0.01	2.0 -	1.1 -	5.9 -
Buckwheat	8.89 0.14	7.55 <0.01	5.58 <0.01	4.77 <0.01	2.65 <0.01	3.99 <0.01	1.37 0.07	2.0 -	<0.01	2.8 -	0.9 -	7.5 -

Table is adapted from Lyons and co-workers 2020 [ref:1028] and Li and co-workers 2019 [ref:1252] – weighted samples of children (7-10 years) with and without allergic symptoms completed a questionnaire and donated serum for IgE analysis; probable food allergy was defined as sIgE and reported hypersensitivity-related symptoms within 2 hours after ingestion"

three foods to which the most symptoms of probable allergy were reported. Seed allergy was much less commonly reported. Despite low prevalence of sunflower seeds allergy in Athens, at 0.07%, this still appears as one of the foods with the most reported probable food allergy in this centre.¹⁰²⁹

In a combined population of children and adults who reported allergic reactions to hazelnut (70% had a confirmed hazelnut allergy by DBPCFCs or history of severe allergy), sensitization to Cor a 1 was most prevalent (74.3%), followed at distance by Cor a 2 (19.6%), and up to 10 times higher than sensitization to other hazelnut components. While sensitization to Cor a 14 was highly associated with sensitization to Cor a 9 with a higher prevalence in children

(42.0% vs 5.8%), sensitization to Cor a 11 was overall below 10%. Geographical differences were shown for Cor a 1 (more prevalent in Northern and Central Europe, ≥60%), closely related to sensitization to birch pollen, and for Cor a 8 (more prevalent in the Mediterranean area, ranging from 36% to 83%). Sensitization to oleosin Cor a 12 was observed all over Europe in up to 25% of the patients with a higher rate in children (11.4% vs 34%) [10]. Comparable to hazelnut, sensitization to the PR-10 protein Jug r 5 in walnut dominated in the birch-pandemic area with high correlation to birch pollen sensitization whilst sensitization to the LTP Jug r 3 dominated in Southern Europe. Notably, sensitization to walnut seed storage proteins was found in up to 10% of enrolled subjects.⁴⁶

TABLE 58 Prevalence of food sensitization in comparison to probable food allergy in adults across Europe

	Zurich	Madrid	Utrecht	Lodz	Sofia	Reykjavik	India
Hazelnut	17.79	6.00	11.95	6.54	6.27	1.27	7.27
	2.57	0.76	0.93	1.33	-	0.10	<0.01
Walnut	5.59	7.65	1.86	3.57	2.69	0.07	6.21
	0.58	0.71	0.10	0.15	-	0.05	<0.01
Sesame	7.61	10.24	3.24	4.26	4.48	1.27	13.97
	0.03	<0.01	<0.01	<0.01	-	<0.01	0.02
Mustard	3.59	2.71	0.41	1.71	2.69	0.37	4.68
	<0.01	<0.01	<0.01	0.03	-	<0.01	<0.01
Sunflower	5.81	8.24	1.86	3.49	2.69	0.75	8.20
	0.05	<0.01	<0.01	<0.01	-	<0.01	<0.01
Poppy seed	5.44	7.77	1.38	3.12	3.58	0.97	8.71
	<0.01	<0.01	<0.01	<0.01	-	<0.01	<0.01
Buckwheat	6.18	7.06	0.89	3.05	3.58	0.74	12.41
	<0.01	<0.01	<0.01	<0.01	-	<0.01	<0.01

Table is adapted from Burney and co-workers 2014 [1144], Lyons and co-workers 2019 [1031] and Mahesh boonand co-workers 2016 [1677] – weighted samples of adults with and without allergic symptoms completed a questionnaire and donated serum for IgE analysis; probable food allergy was defined as sIgE and reported hypersensitivity-related symptoms within 2 hours after ingestion.

Australian data from the SchoolNuts study published in 2018 reported the prevalence of clinic-defined tree nut allergy to be 2.3% and sesame allergy to be 0.2% in adolescents. Amongst tree nuts, the most prevalent allergies were cashew nut allergy at 2.3% and pistachio nut allergy at 1.6%. Other tree nut allergies were less common and varied from 0.1% to almond and Brazil nut to 0.7% to walnut and hazelnut.¹²⁵² The patterns of sensitization through childhood reported by the SchoolNuts Study team were interesting. Preceding results reported by the same team had shown very low rate of tree nut allergies in Australian infants, with 0.1% of infants having an allergic reaction by the age of one, but sensitization to tested tree nuts was detected in 31% of infants who had other food allergies, particularly peanut and hen's egg allergy. At age 6 years, prevalence of sensitization to tree nuts was 7.3% and tree nut allergy was 3.3%, with cashew nut allergy being the most common at 2.7%, followed by hazelnut at 0.9% and almond at 0.3%.¹²⁵³ In an American study from 2010, self-reported tree nut allergy in 1997, 2002 and 2008 was found in 0.5%, 0.7% and 0.6% respectively, of the population. By contrast, only 0.1% reported sesame allergy.¹²⁵⁴

During the last decade, several papers have appeared on allergic reactions to cashew nut. In a recent review on cashew nut allergy, the authors concluded that an increase of sensitization in cashew nut allergy in recent decades could not be clearly documented, despite the impression that this has been the case, particularly as exposure to cashew nut has increased in the population.¹²⁵⁵ Cashew nut is now used in industrial food as a replacement for the more

expensive pine nuts and for its properties of improving texture and displaying a more reduced rancidity. In a recent population-based study of children admitted to emergency rooms due to reaction to foods in Stockholm during 2007, 5% had reacted to cashew nut, 3% to hazelnut, 2% to almond, walnut, or pistachio, whereas 0.3-0.5% reported reactions to pecan nuts, Brazils nut or coconut.¹²⁵⁶

5 – Clinical relevance of sensitization to individual allergenic proteins

The clinical relevance of sensitization to individual allergens is most studied in hazelnut, followed by walnut, cashew nut and sesame seed. In order to diagnose a hazelnut allergy in children, the area under the curve (AUC) for sIgE is the largest for Cor a 14 (0.87) and Cor a 9 (0.81) whilst sIgE to Cor a 1 (0.55) or Cor a 8 (0.59) have no additional value in diagnosing hazelnut allergy compared with hazelnut extract.¹²⁴⁹ It has to be considered that the hazelnut extract might be spiked with Cor a 1 (known for the ImmunoCAP platform¹²⁵⁷). Notably, as described in section 2, the prevalence of sensitization (Cor a 1, 2 and 8) seems to inversely correlate with the risk of an allergic reaction to hazelnut and sensitization to Cor a 9 and 14, as shown in (Figure 121). In adults, the AUC for Cor a 9 and Cor a 14 is decreased to 0.66 and 0.67, respectively, as described by Masthoff and co-workers,⁴³ probably due to the increased prevalence of sensitization to Cor a 1 in the adult population.⁴⁴ Data on sensitization to walnut, cashew nut, and

sesame seed support the clinical relevance of sIgE to 2S albumins of different sources.^{46,1255,1258,1259} However, robust data on severity of an allergic reaction to those nuts and sensitization to individual allergens, as shown for peanut allergens, are lacking.

Cross-reactivity across tree nuts and seed allergens

Seed storage proteins such as 2S albumins, 7S globulins, and 11S globulins, share parts of their amino acid sequences across tree nuts and seeds (Figures 122–124). Due to this homology, they also share common IgE-binding epitopes, which leads to IgE cross-reactivity *in vitro* and potentially to clinically relevant cross-reactivity. However, as antibodies may bind to specific epitopes residing in regions that are more conserved (less variable) than the entire protein, cross-reactivity may also occur to a higher extent than indicated by the overall percentage sequence identity. Accessibility of epitopes, especially for 11S globulins, which consist of dimer of homotrimers, also has to be considered. This has been shown for nonhomologous peanut allergens Ara h 1, Ara h 2 and Ara h 3 (see section C-10).

Such homology is particularly high between 2S albumins of phylogenetically related plants such as cashew nut and pistachio (Anacardiaceae family) and between walnut and pecan nut (Juglandaceae family). Cross-reactivity between those tree nut combinations has not only been shown *in vitro* but also its clinical relevance has been proven. While clinically relevant sensitization to pistachio and pecan nut always implies clinically relevant sensitization to cashew nut and walnut, respectively, the reverse does not always occur. Hence, cashew nut Ana o 3 and walnut Jug r 1 are considered to be the respective primary sensitizers.¹²⁶⁰ As shown in (Figure 121), Cor a 14 and Jug r 1 share a lower but still significant sequence identity of 66%. Such high sequence identity can lead to clinically relevant IgE cross-reactivity. The ProNut study confirmed clinically relevant cross-reactivity between walnut, pecan nut, hazelnut, and macadamia in descending order.¹²⁶¹ Other sequence identities of this protein family range from 24% to 49%.

Regarding 7S globulins, the highest sequence identities are also shared between cashew nut Ana o 1 and pistachio Pis v 3 (81%) and

walnut and pecan nut (93% for Jug r 2 and 44% for Jug r 6), whereas hazelnut Cor a 11 and walnut Jug r 2 only share a sequence identity of 49%. However, Jug r 2 carries cross-reactive carbohydrate determinants (CCD), which makes it difficult to draw firm conclusions on any associations. The newly identified walnut 7S globulin Jug r 6 shares higher homology with Cor a 11 (76%), Ana o 1 (59%) and Pis v 3 (62%). The sequence homology of 7S globulin between other tree nuts and seeds, ranged from 27% to 58%.

For the 11S globulins, the sequence homology between the different nuts and legumes shows a slightly different picture with higher homology in general. Again, the rather high homology between the 7S globulins of cashew and pistachio, as well as hazelnut and walnut are evident. High homology of the hazelnut Cor a 9 with the corresponding 11S globulins from poppy seed and buckwheat (Fag e 1) points to a potential for both IgE and clinical cross-reactivity.¹²⁶² Notably, clinically relevant cross-reactivity has been described between buckwheat and latex. However, the implicated allergen has not yet been identified.¹²⁶³

6 – Tree nut and seed allergy diagnosis and management

Clinical pattern and relevance

Five clear patterns of clinical relevance have been described amongst individuals sensitized or allergic to tree nuts and seeds.

- A Primary sensitization to one tree nut or seed allergen;
- B Co-sensitization to at least two primary tree nut and/or seed allergens;
- C Primary sensitization and allergy to at least one tree nut or seed and cross-reactive IgE to another phylogenetically related tree nut or seed (high degree of sequence homology);
- D Primary sensitization and allergy to at least one tree nut or seed and cross-reactive IgE to another phylogenetically not closely related tree nut or seed (low to moderate degree of sequence homology);
- E Primary sensitization to pollen and cross-reactive IgE between PR-10 and LTP allergen proteins in tree nuts and seeds.

Example for pattern A. The patient is sensitized to only one tree nut or seed out of several tested. Irrespective of symptoms the IgE is relatively low. This patient is in general of younger age. At a very low age, IgE levels below 0.35 kU/L can be found in children reacting to nuts. This patient should avoid the culprit nut or seed but no other nuts and seed if they have tested negative to them.

Example for pattern B. This patient is often polysensitized to nuts and/or seeds with relatively high sIgE levels to all tested relevant allergens. A patient with tree nut or seed allergy and polysensitization with generally high sIgE is recommended to avoid all tree nuts with total restriction and to avoid any seeds that are causing symptoms.

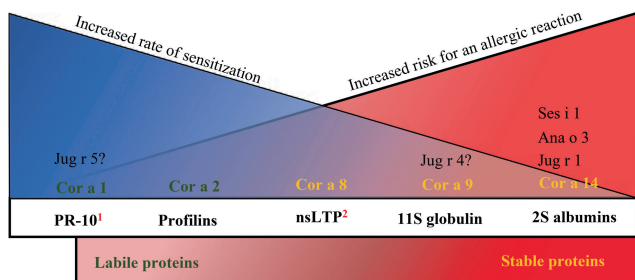


FIGURE 121 Risk ramp for hazelnut allergens: increased risk for allergic symptoms from the left to the right and increased rate of sensitization from the right to the left. In case of known clinical relevance, the ramp was supplemented with the known risk of other seed allergens. Green: Pollen-related highly cross-reactive allergens, Yellow: Food allergens with increased thermal stability and digestive resistance; 1: common in Northern and Central Europe, hazelnut extract is spiked with the PR-10 protein, 2: increased sensitization in the Mediterranean area

Cor a 14												
Jug r 1	66%											
Car i 1	62%	87%										
Ana o 3	44%	38%	41%									
Pis v 1	43%	39%	37%	69%								
Ber e 1	45%	44%	42%	32%	33%							
Pin p 1	35%	33%	35%	30%	30%	28%						
Ses i 1	42%	40%	40%	37%	34%	30%	32%					
Sin a 1	28%	29%	31%	27%	27%	22%	20%	28%				
Cuc ma 5	38%	42%	38%	38%	32%	38%	27%	34%	25%			
Fag e 2	25%	27%	26%	24%	21%	25%	24%	22%	16%	21%		
Lin u 1	31%	32%	33%	31%	28%	23%	26%	32%	25%	33%	21%	
	Cor a 14	Jug r 1	Car i 1	Ana o 3	Pis v 1	Ber e 1	Pin p 1	Ses i 1	Sin a 1	Cuc ma 5	Fag e 2	Lin u 1

FIGURE 122 Amino acid sequence identity among 2S albumins between different tree nuts and seeds (without signal sequence; bold >50%) Cora 14: D0PWG2; Jug r 1: P93198; Car i 1: Q84XA9; Ana o 3: Q8H2B8; Pis v 1: B7P072; Ber e 1: P04403; Pin p 1: A0A0K3AVY3; Ses i 1: Q9AUD1; Sin a 1: P15322; Cuc ma 5: Q39649; Fag e 2: Q2PS07; Lin u 1: Q8LPD3

Cor a 11												
Jug r 6	76%											
Car i 2	47%	44%*										
Ana o 1	55%	59%	38%									
Pis v 3	59%	62%	40%	82%								
Pru du 8	18%	25%	31%	27%	27%							
Mac i 1	44%	44%	45%	40%	41%	28%						
Coc n 1	26%	24%	24%	25%	26%	18%	26%					
Ses i 3	56%	58%	44%	50%	53%	31%	43%	26%				
Fag e 3	24%	21%	32%	29%	29%	27%	31%	15%	23%			
	Cor a 11	Jug r 6	Car i 2	Ana o 1	Pis v 3	Pru du 8	Mac i 1	Coc n 1	Ses i 3	Fag e 3		

FIGURE 123 Amino acid sequence identity among 7S globulins between different tree nuts and seeds Cor a 11: Q8S4P9; Jug r 6: A0A2I4E5L6; Car i 2: B3STU4; Ana o 1: Q8L5L5; Pis v 3: B4X640; Pru du 8: A0A516F3L2; Mac i 1: Q9SPL3; Coc n 1: A0A0S3B0K0; Ses i 3: Q9AUD0; Fag e 3: A5HIX6 (only fragment available), *Homology between Jug r 2 and Car i 2 is 93%

Cor a 9												
Jug r 4	75%											
Car i 4	73%	95%										
Ana o 2	58%	63%	62%									
Pis v 5	58%	60%	60%	78%								
Pru du 6	57%	56%	56%	50%	52%							
Ber e 2	53%	52%	53%	51%	50%	47%						
Ses i 7	51%	53%	53%	53%	50%	48%	51%					
Sin a 2	47%	47%	47%	47%	49%	45%	42%	44%				
Cuc ma 4	47%	49%	49%	48%	46%	44%	46%	49%	39%			
Fag e 1	42%	44%	43%	45%	42%	41%	48%	44%	37%	43%		
	Cor a 9	Jug r 4	Car i 4	Ana o 2	Pis v 5	Pru du 6	Ber e 2	Ses i 7	Sin a 2	Cuc ma 4	Fag e 1	

FIGURE 124 Amino acid sequence identity among 11S globulins between different tree nuts and seeds Cor a 9: Q8W1C2; Jug r 4: Q2TPW5; Car i 4: B5KVH4; Ana o 2: Q8GZP6; Pis v 5: B7SLJ1; Pru du 6: E3SH28; Ber e 2: Q84ND2; Ses i 7: Q9AUD2; Sin a 2: Q2TLW0; Cuc ma 4: P13744; Fag e 1: K4PY05

Example for pattern C. The patient is sensitized to cashew nut and pistachio, or to walnut and pecan nut with rather equal sIgE levels between the botanically related groups of tree nuts. Patients sensitized to only cashew nut and pistachio should only avoid those tree nuts. No other restrictions should be made. The same recommendation would be appropriate for patients sensitized and allergic to only walnut and pecan nut. Testing for other tree nut allergies is required prior to considering introduction. For patients sensitized to walnut, clinical cross-reaction to hazelnut and macadamia may occur.¹²⁶¹

Example for pattern D. This is the most common pattern in patients with tree nut allergy: allergic to several nuts with high sIgE levels to those tree nuts, but much lower sIgE levels to other tree

nuts. Usually, those patients tolerate other nuts well, but this needs to be confirmed by oral food challenge (OFC). In the ProNuts study, children allergic to at least one tree nut were, on average able to tolerate 9 other tree nuts or sesame seed by undergoing sequential OFCs.¹²⁶¹

Example for pattern E. This patient is most likely birch pollen allergic (Bet v 1) if s/he is resident in Northern Europe. If resident in Southern Europe, positive IgE to Artemisia, Paretaria or plane tree (LTP) may be present. Approximately 80% of the population with concurrent birch pollen allergy will experience "birch pollen related food allergy" to other PR-10 allergens. The PR-10 allergen Cor a 1 is unstable to gastric digestion and is heat labile. Symptoms in the oral cavity may be unpleasant but will not cause systemic

reactions under normal circumstances. In most tree nuts and seeds, PR-10 proteins are likely to be present, most notably in Fagales trees (plant order that include: *Betulaceae* (Birch, Alder, Hazel tree, Hornbeam), *Fagaceae* (chestnut, trigonobalanus, beech tree, oak tree), *Juglandaceae* (walnut, hickory, wingnuts tree), *Myricaceae* (bayberry), *Nothofagaceae* (southern beech), *Casuarinaceae* (she-oak), and *Ticodendraceae* family).

Clinical diagnosis

Specific questions, appropriate interpretation of sensitization test results and, under certain conditions, open or blinded OFCs will help to establish the diagnosis of tree nut and seed allergy and the grade of severity. The following work-up might facilitate an accurate diagnosis, which will be beneficial for the patient (Figure 125).

Detailed patient history:

The following are examples of questions that will help establish a detailed patient history:

- Were there previous reaction(s) to tree nuts and/or seeds or is this the first reaction?
- Did the patient previously tolerate the offending food?
- What were the symptoms, and which were the affected organs?

- Were multiple foods ingested or multiple nuts?
- What was the approximate dose causing the symptoms?
- What was the time for onset of symptoms after ingestion?
- What is the estimated time until the administration of the adrenaline autoinjector (AAI)?
- What was the response to injection of adrenaline?
- Were one, two or more AAI used?
- Did the patient engage in concomitant exercise, take nonsteroidal anti-inflammatories (NSAID), consume alcohol, or other potentially aggravating factors?
- Is the patient birch pollen allergic or allergic to plants with pollen containing LTPs?

Appropriate interpretation of sensitization results:

Skin prick test (SPT)

Commercial extracts of tree nuts and seeds or prick-to-prick test with fresh tree nuts or seeds have a limited value due to false positive responses in case of cross-reactive labile tree nut/seed allergenic proteins, such as Cor a 1. However, they are an important first step in the diagnostic algorithm for evaluation of tree nut and seed allergies.

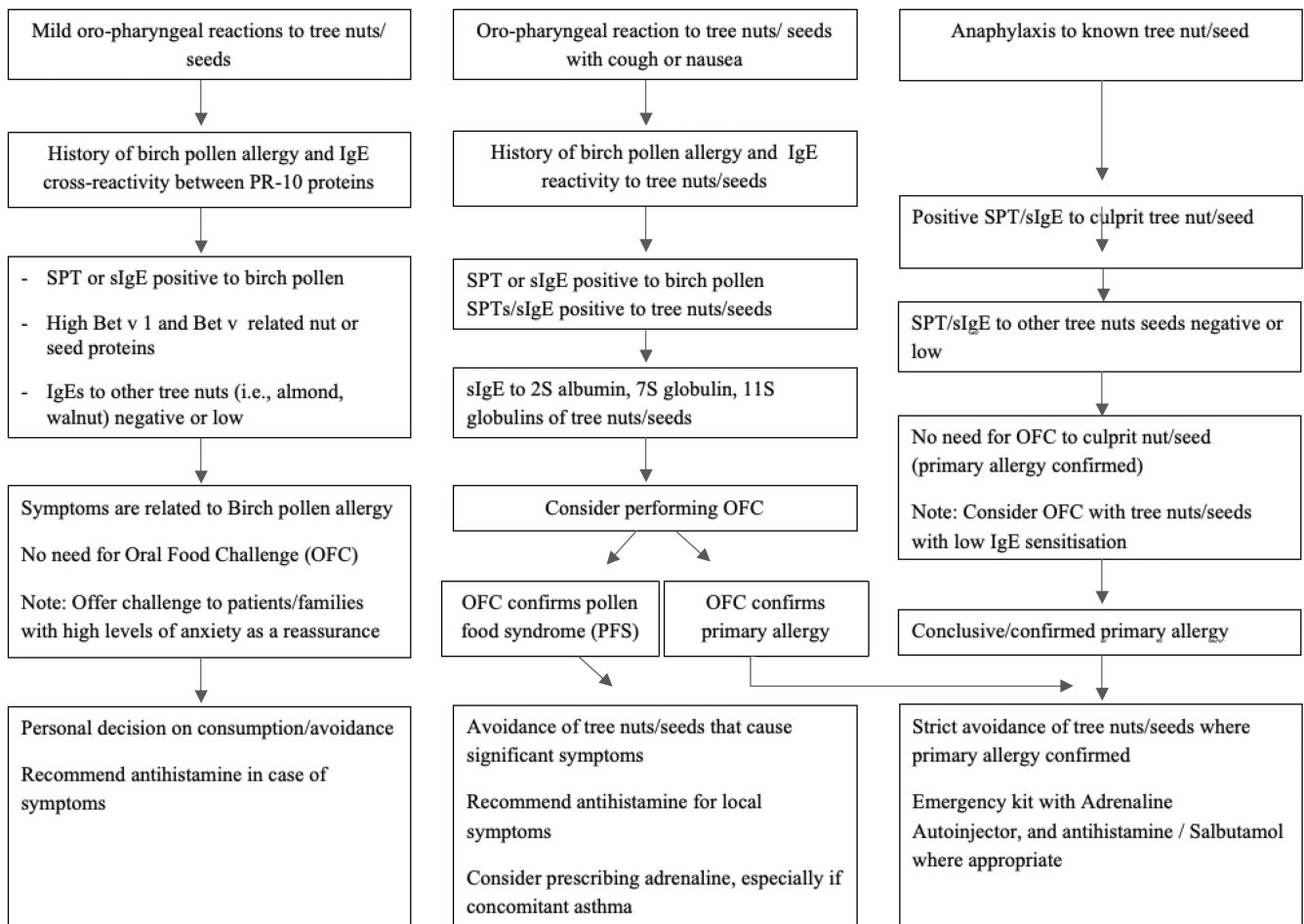


FIGURE 125 Diagnostic work-up in tree nut, peanut and/or seed-related allergic reactions Arrows indicate potential diagnostic steps; dashed arrows indicate that mild and severe reactions can be associated with different clinical features (based on information from the detailed patient history).

IgE Testing

Total IgE measurements do not aid in the diagnosis of specific tree nut or seed allergies. It may, however, explain polysensitization to multiple nuts and seeds in patients with a highly raised total IgE who may only react clinically to one particular food.

In clear cases with exposure to a single tree nut or seed followed by a systemic reaction one could question whether sIgE testing is needed. However, the rationale for performing sIgE testing is to confirm the presence of allergen-specific IgE and examine the possibility of co-sensitization or cross-reactive IgE to other tree nuts or seeds and to assess the risk of a reaction at exposure:

- In hazelnut or walnut allergic individuals, sIgE to Cor a 14 and Jug r 1, with a sequence homology of 66%, could be tested (clinical pattern A, B or D). In patients with a history of allergic reactions to hazelnut, sIgE to Cor a 14 and Cor a 9 can be measured to disentangle primary allergy from sensitization to solely Cor a 1 (if tree nut-related clinical pattern A-D),
- sIgE to Cor a 1 and/or Bet v 1 or Cor a 8 and LTP containing pollens could confirm the pollen food syndrome (if hazelnut-related clinical pattern E),
- For tree nut or seed extracts containing PR-10 protein (hazelnut extract is spiked with Cor a 1, known for the ImmunoCAP platform [21]) or LTPs: risk of clinically irrelevant false positive results (clinical pattern E),
- For other tree nuts and seeds allergen components, there is to date little experience in clinical practice; however, sensitization to 2S albumins of cashew nut (Ana o 3), pistachio (Pis v 1) and sesame (Ses i 1) seem to be a reliable marker for clinically relevant sensitization (pattern A, B and D)

For interpretation of sensitization test results see also (Figure 125). Results are only clinically relevant in case of corresponding symptoms after tree nut or seed ingestion.

Basophil activation testing (BAT) can also be performed with tree nuts and seeds allergens, such as from hazelnut.¹²⁶⁴ In contrast to peanut allergy, their diagnostic implications are not yet clear.

Oral food challenges

Oral food challenges (open or blinded) should be performed in cases of doubtful relationship between reported symptoms following ingestion and sIgE test results and in patients who have avoided certain tree nuts, legumes/peanuts or seeds due to a previous reaction to this kind of foods and sensitization to that food can be demonstrated:

Depending on the clinical pattern (A – E), an oral food challenge with standardized increasing doses of the offending food may be performed. It is important to not stop at a too low dose: PRACTALL guidelines of 4.43 g of tree nut protein (2 grams top dose).¹²⁶⁵ Low

dose challenge in tree nut/seed allergic individuals to reduce fear of products labelled with “may contain” may play a role in improving quality of life and dietary restrictions.

Airborne challenges for those with a fear being in an environment where nuts/seeds are present (restaurants, cafés, parties, travelling by air) may be helpful in certain specific cases.

Clinical management

Allergen avoidance

Balanced avoidance of the offending tree nut, and/or seeds. If a patient is likely to experience a systemic reaction on a minor dose, a high degree of precaution is required. If reactions due to PR-10 allergy, it is up to the patient to decide on amount of exposure.

Pharmacotherapy (emergency kit)

In patients with previously anaphylaxis or systemic reactions on a minor dose, emergency medication including AAI for self-administration is required accompanied with a personalized emergency treatment plan. As reactions to tree nuts and seeds may be variable, some centres will prescribe AAI even when mild allergic reactions to these foods have been experienced¹²⁶⁶ [30].

Nonsedating antihistamines are useful for the management of mild to moderate reactions, but adrenaline is the first line treatment for anaphylaxis and antihistamines are relegated to a second or third-line treatment.

Steroids are no longer part of standard treatment for allergic reactions unless asthma exacerbation may have contributed to severity of anaphylaxis or in case of refractory anaphylaxis. Additional symptomatic treatment as required.

Allergen-specific immunotherapy

At present, commercially available products for allergen-specific immunotherapy of tree nut or seed allergies are not available. Research into tree nut and sesame desensitization is ongoing in certain US centres and commercial companies are working on walnut and cashew nut desensitization.

Birch pollen immunotherapy has also been considered as a treatment option in patients with respiratory allergy and pollen food syndrome to variety of fruits, vegetables, and nuts. Next to birch pollen allergy, the patients suffered from pollen food syndrome mainly to apple and hazelnut. Unfortunately, results from those studies are not very consistent. While some studies reported significant reduction and even complete resolution of pollen food syndrome symptoms in some participants,^{1172,1266} other studies were not able to confirm such an effect.^{1173,1267} In addition, studies investigating the role of immunotherapy in patients with pollen food syndrome were primarily designed to investigate the efficacy of immunotherapy in allergic rhinitis, they usually included small numbers of participants, and they were necessarily not double-blind placebo controlled. Nevertheless, immunotherapy remains as a treatment of interest, particularly in patients with severe symptoms of pollen food syndrome, that requires further research.

B20 – Bee venom allergy

Simon Blank, Maria Beatrice Bilò, Thilo Jakob, Markus Ollert

Highlights

- In honeybee venom allergy, CRD is a valuable tool since CCD-free Api m 1, Api m 3, Api m 4 and Api m 10 are marker allergens for detection of specific IgE sensitization to honeybee venom.
- The differentiating marker allergens Api m 1, Api m 3, Api m 4 and Api m 10 allow discrimination between primary sensitization to honeybee and vespid venom.
- There are no marker allergens available that allow discrimination between primary honeybee and bumblebee venom sensitization.
- It is recommended to determine the baseline serum tryptase level in all patients with a history of a systemic sting reaction.
- Venom-specific immunotherapy is an effective treatment to protect against future severe sting reactions.

1 – The allergen sources

Hymenoptera venom allergy is one of the most serious IgE-mediated hypersensitivities due to the high risk of severe and even fatal anaphylaxis. In adults (> 18 years), 48.2% of cases of severe anaphylaxis are caused by Hymenoptera stings (20.2% in children).¹²⁷³ Bees (Family *Apidae*) are flying insects of the order Hymenoptera with more than 5.700 known species (Figure 126). The most common elicitors of bee venom allergy are honeybees (*Apis spp.*), which are known for their outstanding role in pollination and for producing honey and beeswax.

Only two honeybee species have been truly domesticated, whereby *Apis mellifera* (European, western or common honeybee) (Figure 127) is the most common domesticated species and shows a world-wide distribution due to human-induced global dispersal. The other domesticated species *Apis cerana* (eastern honeybee) is native to southern and eastern Asia. Primary allergy to bumblebee (*Bombus spp.*) venom (BBV) is rare and primarily workplace-associated as bumblebees (Figure 127) are increasingly used for pollination in greenhouses.

Sensitization to bee venom occurs after a sting, whereby honeybees are the only stinging Hymenoptera that nearly always leave their stinger with adherent venom sac in the skin of the victim. Meanwhile the venom is continuously pumped into the skin until the venom sac is exhausted or the stinger removed.

2 – Allergen families and allergenic molecules

Bee venom is a complex mixture of low molecular weight substances such as biogenic amines and basic peptides and of higher molecular weight proteins, many of them with enzymatic activity. The venom of the honeybee *Apis mellifera* is one of the best characterized Hymenoptera venoms. In addition to well-established honeybee

venom (HBV) allergens, several new relevant allergens of low abundance were identified in the last decade mainly by proteomic approaches (Figure 128). Currently, 12 different HBV allergens are listed in the WHO/IUIS allergen nomenclature database. By contrast, BBV is less well investigated and only two allergen families (phospholipases A2, Bom t 1 and Bom p 1; protease, Bom t 4 and Bom p 4) are listed in the WHO/IUIS allergen nomenclature database (Figure 128).

Many allergens of bee venoms are proteins, which exhibit direct toxicity in the stung victim. Others have functions in the venom sac such as activation of toxic proteins, thereby, protecting the surrounding tissue of the venom gland. The venom allergens of different honeybee species are highly similar and also bumblebee venom closely resembles honeybee venom. Both venoms are reported to be highly cross-reactive.¹²⁷⁴ The IgE-binding capacity of most of the bee venom allergens seems to depend on correct three-dimensional folding of the molecules (Figure 129).

Both HBV and BBV contain phospholipases A2 (PLA2) (Api m 1, Api c 1, Api d 1, Bom t 1, Bom p 1) as relevant major allergens. PLAs2 are hydrolases that cleave fatty acids from phospholipids in cell membranes at the sn-2 position. This enzymatic activity leads to direct toxic effects such as cell lysis, pore formation and release of pro-inflammatory mediators. Additionally PLAs2 mediate catalytic-independent neurotoxicity by binding to N-type receptors. PLA2 makes up for up to 16% of the venoms dry weight. Although phospholipases A1 of vespid venoms catalyze a related enzymatic reaction, they share neither sequence identity nor structural similarity with PLAs2 of bee venom. The resulting lack of cross-reactivity renders PLAs ideal marker allergens to discriminate between bee and vespid sensitization.

The main component of HBV (50% of dry weight) is melittin (Api m 4), a cytotoxic 26 amino acid peptide that as a tetramer integrates into cell membranes and induces cell death, destruction of mast cells and vascular dilation. Moreover, melittin is the main pain-inducing substance of HBV mediated by the activation of nociceptors.

Together, Api m 1 and Api m 4 account for more than 60% of the HBVs' dry weight. By contrast, all other allergens are present in comparably low amounts. Nevertheless, several of them are of high relevance in allergy diagnosis (Figure 128, Table 59)

Hyaluronidases are common components of Hymenoptera venoms and have been annotated as allergens for eight species, including the honeybee *Apis mellifera* (Api m 2). So far, no allergenic hyaluronidase is annotated for BBV. Hyaluronidases cleave hyaluronan, a main component in vertebrates' extracellular matrix. Therefore, they promote the spreading of the venom at the injection site. Api m 2 shares 44-53% sequence identity and extended structural similarity with the hyaluronidases of yellow jacket (*Ves v 2*) and European paper wasp (*Pol d 2*) venom. However, cross-reactivity independent of cross-reactive carbohydrate determinants (CCDs) seems to be limited.

So far, acid phosphatase was only annotated as allergen for HBV (Api m 3). However, also BBV contains an allergenic acid phosphatase that shows moderate cross-reactivity with Api m 3. The function of acid phosphatases in Hymenoptera venoms so far remains

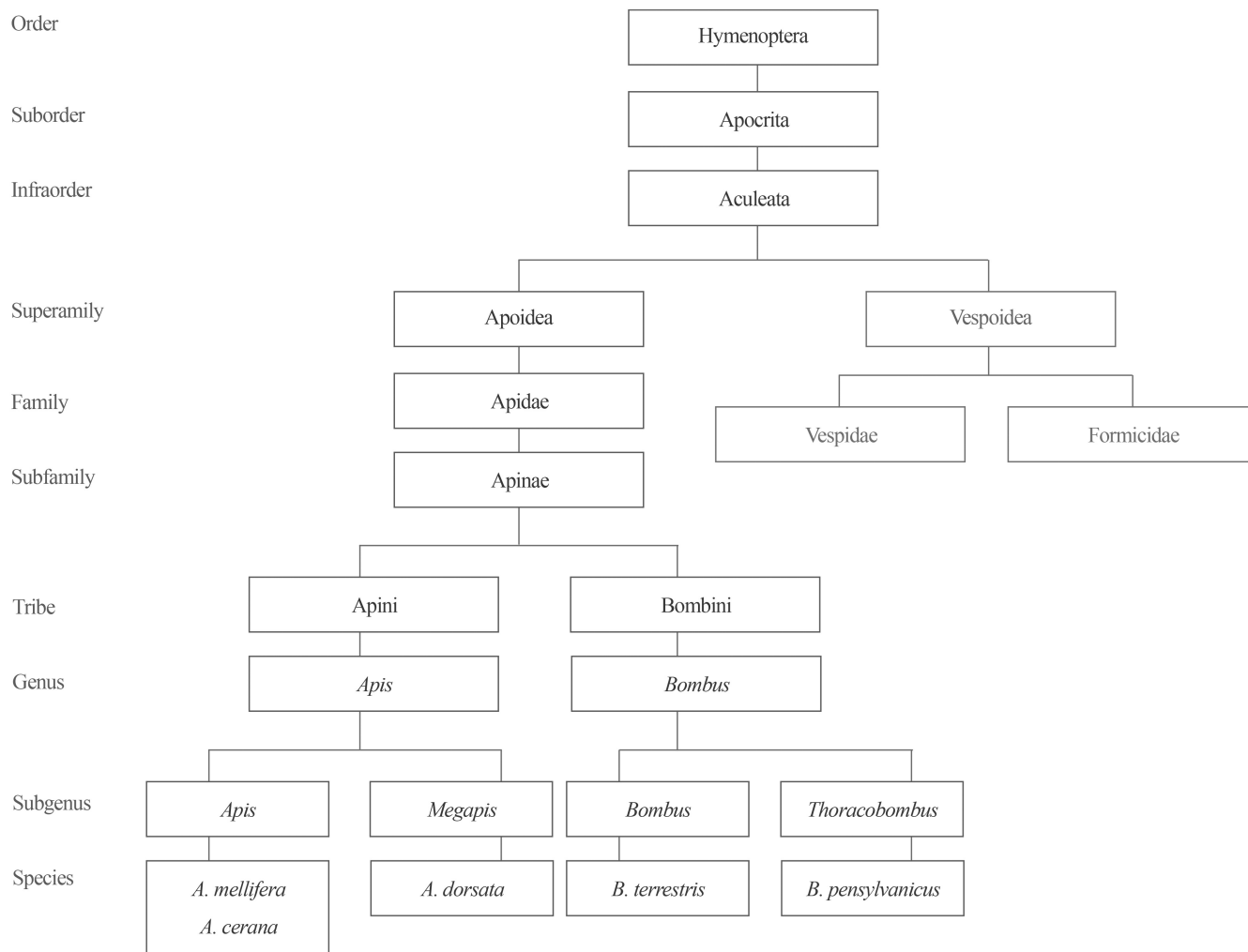


FIGURE 126 Taxonomy of allergy-relevant bee species. As the taxonomy of the order Hymenoptera is highly complex, only a selection of allergy-relevant taxa is shown. Only those species are included that are listed in the WHO/IUIS allergen nomenclature database. For taxonomic overview of allergy-relevant vespids (Vespidae) refer to the vespid venom chapter. The family Formicidae (ants) also contains species with relevance for Hymenoptera venom allergy.



FIGURE 127 The honeybee and the bumblebee

elusive. They may catalyze the liberation of purines, mainly adenosine, which act as multitoxins.

Another protein family found in several Hymenoptera venoms is the family of dipeptidyl peptidases IV (DPPIV).

The DPPIV of HBV (Api m 5) catalyzes the conversion from promelittin to melittin by liberating dipeptides from the N-terminus. By only activating melittin in the venom sac, the honeybees probably protect themselves against its toxic effects. HBV Api m 5 exhibits extensive cross-reactivity with the homologous allergens of yellow jacket and European paper wasp venom Ves v 3 and Pol d 3, respectively.

Icarapin (Api m 10) is a protein of so far unknown function in HBV that contains no known functional domains. Nevertheless, it is a conserved protein, as icarapin-like proteins were identified in various species of the phylogenetic class Insecta. Structure predictions reveal that large parts of the protein seem to be disordered (Figure 129). So far no homologous allergens have been described in any other species.

Other less investigated bee venom allergens include protease inhibitor (Api m 6), CUB serine protease (Api m 7), carboxylesterase (Api m 8), serine carboxypeptidase (Api m 9), major royal jelly protein

FIGURE 128 Annotated allergens of honeybee (*A. mellifera*) and bumblebee (*B. terrestris*) venom. For HBV, only selected allergens with proven high relevance are depicted. Allergens from the same protein family are shown in identical colors.

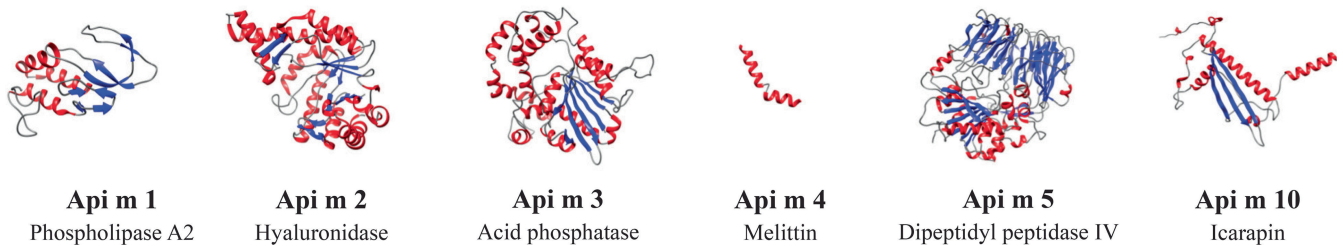
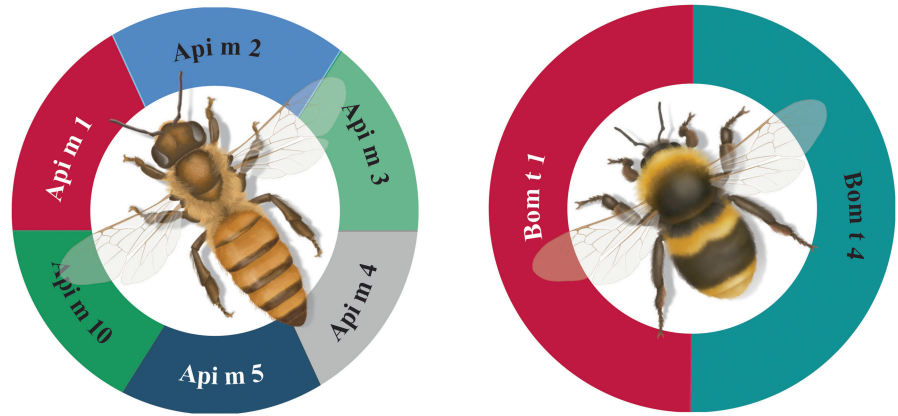


FIGURE 129 Structures of selected relevant honeybee venom allergens. α -helices, β -strands and coiled regions are shown in red, blue and grey, respectively. The structures of Api m 1 (PDB: 1POC) and Api m 2 (PDB: 1FCU) were solved by crystallography. All other structures were generated by structural modeling.

TABLE 59 Most relevant allergens of honeybee (*A. mellifera*) venom

Allergenic molecule	Biochemical name	Prevalence among patients (%)	Molecular weight (kDa)
Api m 1	Phospholipase A2	57-97 87, 101, 1301, 1302, 1304, 1681, 1682, 1683, 1684, 1685, 1686, 1687, 1688, 1689	16
Api m 2	Hyaluronidase	28-60 87,101, 1302, 1304, 1681, 1683, 1688, 1689	39
Api m 3	Acid phosphatase	28-63 87,101, 1681, 1689	43
Api m 4	Melittin	17-54 87,101, 1281, 1688	3
Api m 5	Dipeptidyl peptidase IV	16-70 87,101, 1681, 1688	100
Api m 10	Icarapin	35-73 87,101,99, 1681, 1688	50-55

8/9 (Api m 11), vitellogenin (Api m 12) and protease (Bom t 4, Bom p 4). An overview of the honeybee and bumblebee venom allergens, which are presently listed in the WHO/IUIS allergen nomenclature official database, is given in (Table 60).

3 – Sensitization to individual molecules and their clinical relevance

Approximately 9 to 42% of the adult population shows a sensitization to Hymenoptera venom (including bees and vespids) without previous history of a sting reaction.^{1275,1690} As the presence of specific IgE (sIgE) does not necessarily imply clinically relevant venom allergy, for most of these patients it is likely that the sensitization is asymptomatic. A recent study showed that baseline sIgE levels to bee venom, vespid venom, rApi m 1, and rVes v 5 did not differ between asymptotically sensitized subjects, allergic patients, and VIT-treated patients.¹²⁷⁶

The prevalence of systemic reactions to Hymenoptera stings among adults ranges between 0.3 and 7.5%.^{1275,1277} The prevalence of sensitization to HBV is related to the degree of exposure. Thus, the frequency of honeybee venom allergy is higher in rural than in urban populations and especially beekeepers and their family members are at a higher risk for honeybee venom allergy.¹²⁷⁸

Previous analyses of the sensitization to individual allergens using native purified allergens or immunoblots with venom extracts are only partially reliable due to the interference of clinically irrelevant IgE antibodies directed against CCDs, N-linked glycan structures present on several Hymenoptera venom allergens. Nowadays, advanced recombinant strategies allow the production of correctly folded allergens, devoid of carbohydrate-based cross-reactivity, which allow the elucidation of the role of particular allergens beyond clinically irrelevant cross-reactivity.¹²⁷⁹ Thus, reliable data on sensitization rates are available for several HBV allergens (Table 59).

Detailed data on sensitization rates in HBV-allergic individuals are available for Api m 1 (57-97%), Api m 2 (28-60%), Api m 3

TABLE 60 Overview of the bee venom allergens, which are presently listed in the WHO/IUIS allergen nomenclature official database

Allergenic molecule	Biochemical name	Molecular weight (kDa)
Bumblebees (<i>Bombus pensylvanicus</i> , <i>B. terrestris</i>)		
Bom p 1, Bom t 1	Phospholipase A2	16
Bom p 4, Bom t 4	Protease	27
Honeybees (<i>Apis mellifera</i> , <i>A. cerana</i> , <i>A. dorsata</i>)		
Api m 1, Api c 1, Api d 1	Phospholipase A2	16
Api m 2	Hyaluronidase	39
Api m 3	Acid phosphatase	43
Api m 4	Melittin	3
Api m 5	Dipeptidyl peptidase IV	100
Api m 6	Protease inhibitor	8
Api m 7	CUB serine protease	39
Api m 8	Carboxylesterase	70
Api m 9	Serine carboxypeptidase	60
Api m 10	Icarapin	50-55
Api m 11.0101	Major royal jelly protein 8	45
Api m 11.0201	Major royal jelly protein 9	46
Api m 12	Vitellogenin	200

(28-63%), Api m 4 (17-54%), Api m 5 (16-70%), and Api m 10 (35-73%), which seem to be the most relevant allergens of HBV (Table 59). Of note, the obtained sensitization rates may vary strongly based on the inclusion criteria of the patient population (e.g., mono-sensitized patients versus patients sensitized to different venoms, geographical differences or the method used for sIgE detection)¹²⁸⁰. Other allergens of HBV are less well characterized. However, preliminary, partially unpublished data suggest rather a role as minor allergens. Nevertheless, such allergens may be of special relevance for selected patients. HBV-allergic patients exhibit a wide variety of sensitization profiles to the different HBV allergens.⁸⁷

To date, available studies do not allow a final conclusion if particular sensitization profiles might correlate with the severity of the disease. One prospective study found that Api m 4 sensitization (sIgE > 0.98 kU/L) may be a risk factor for systemic reactions during the initiation phase of venom-specific immunotherapy (VIT) and for more severe systemic reactions after a honeybee sting.¹²⁸¹ Another allergen that is an interesting candidate as marker for personalized risk assessment in VIT is Api m 10. A retrospective multicenter study of VIT-treated HBV-allergic patients showed that a dominant Api m 10 sensitization (defined as >50% of sIgE to whole HBV) represents a relevant risk factor for treatment failure.¹⁰¹ Although the role of particular allergens in allergic reactions and tolerance induction is not finally understood, the knowledge of sensitization profiles in the future may allow a better risk stratification in VIT and thus personalized treatment.

The HBV allergens Api m 1, Api m 3, Api m 4 and Api m 10 can be considered as marker allergens, which in combination with vespidual phospholipases A1 (Ves v 1/ Pol d 1) and antigens 5 (Ves v 5/ Pol d 5), allow to discriminate between HBV and yellow jacket / wasp venom allergy

(Figure 130). Component-resolved diagnostics (CRD) is highly valuable for adequate diagnosis, particularly in double-sensitized patients or in those who were not able to identify the stinging Hymenoptera species. While the hyaluronidase Api m 2 is a major allergen of HBV, the homologous allergens of yellow jacket venom (YJV) (Ves v 2) and European paper wasp (*Polistes dominula*) venom (PDV) (Pol d 2) seem to be of minor allergologic relevance in vespidual venom allergy. Moreover, cross-reactivity beyond CCDs between Api m 2 and its vespidual homologues is limited (Figure 130). Hence CCD-free Api m 2 may contribute as marker allergen to detect primary HBV sensitization. By contrast, the HBV DPPIV Api m 5 exhibits pronounced cross-reactivity with its homologues of YJV and PDV (Ves v 3 and Pol d 3). Additionally vitellogenins (Api m 12 and Ves v 6) contribute to cross-reactivity between HBV and YJV (Figure 130).

4 – Clinical management

Clinical diagnosis

The diagnosis of bee venom allergy comprises the patient history of a systemic sting reaction, a positive skin test response and/or the detection of venom-sIgE antibodies.

Patient history:

One focus of taking the patient history should be the identification of the culprit insect. An important factor for the identification of honeybees is that they are the only stinging Hymenoptera species that nearly always leaves their stinger with adherent venom sac in the skin of the victim. However, several patients are not able to discriminate between honeybee and vespidual stings, so that the results of patient's history often remain inconclusive.

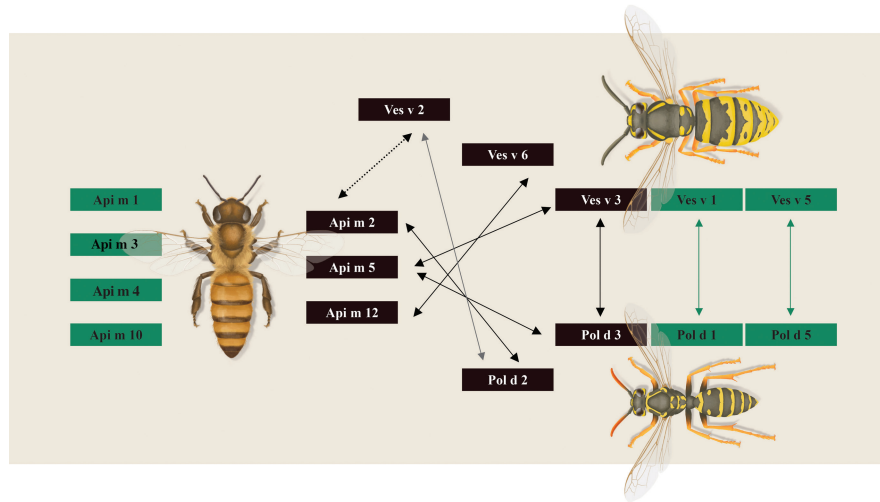


FIGURE 130 Cross-reactivity of honeybee venom allergens and their homologues from vespid venom. Potentially cross-reactive and marker allergens for the discrimination between primary honeybee and vespid venom sensitization are shown in black and green, respectively. Of note, vespid phospholipases A1 (Ves v 1 and Pol d 1) and antigens 5 (Ves v 5 and Pol d 5) can serve as marker allergens to discriminate between vespid and honeybee venom allergy but are highly cross-reactive among each other (green arrows). Black solid arrows: highly cross-reactive; black dotted arrows: limited cross-reactivity; grey arrows: cross-reactive, but detailed studies on its degree are missing.

Moreover, patient history should consider information on number and date of sting reactions, severity of symptoms and the time between sting and the onset of symptoms as well as the assessment of potential risk factors such as medication, cardiovascular risks and other diseases such as mast cell disorders.

Skin tests:

Skin tests are performed as prick test and/or intradermal test with commercial honeybee venom and vespid venom extract at least 2 weeks after the sting reaction to avoid possible false-negative results during the refractory period. For more detailed information please refer to the vespid venom chapter.

Baseline serum tryptase:

It is recommended to determine the baseline tryptase level in all patients with a history of a systemic reaction after a Hymenoptera sting to identify patients at higher risk of developing severe reactions due to undiagnosed clonal mast cell disorders. Adult patients with mast cell disorders and/or elevated baseline serum tryptase are not only at risk of more severe reactions following stings but in some studies are also considered a risk population during VIT for a lower clinical efficacy and/or a greater occurrence of side effects.

It is noteworthy that even in the presence of normal tryptase level, patients with severe anaphylaxis (and absence of urticaria or angioedema) due to stings may suffer from clonal mast cell disorders. Vice versa, high tryptase levels can also be found in other conditions (e.g., hematologic malignancies, parasitic infections, end-stage chronic renal disease, aneurysms of the abdominal aorta, hereditary alpha-tryptasemia).

IgE testing:

Total IgE: Although it is not generally recommended in the guidelines, the measurement of total IgE (tIgE) levels in combination with sIgE test results can be useful to improve and simplify interpretation.

This is particularly relevant in connection with very low sIgE levels, since each sIgE level has a different relevance if produced in an environment with high or low tIgE values. In 54% of Hymenoptera venom-sensitized individuals, the ratio of sIgE/tIgE was >4%.¹²⁸² Thus, in the clinical management of bee venom allergy, the measurement of tIgE can provide guidance to the clinician in the context of the ratio sIgE/tIgE.

Specific IgE to venom extracts and individual venom allergens:

Specific IgE measurements to honeybee and vespid venom extracts might show multiple positive test results due to sensitization to multiple venoms or to the presence of sIgE to CCDs or homologous allergens present in different venoms. Results might be negative due to the underrepresentation of particular allergens in the extract, or a higher sensitivity of individual components. While this has convincingly been demonstrated for Ves v 5 and YJV extract (see chapter on vespid venom allergy), conflicting results were reported in two studies that have addressed this issue in HBV allergy.^{1283,1284}

Specific IgE detection to BBV could be useful in patients heavily exposed to bumblebee stings. Although major allergens of BBV and HBV are cross-reactive, additional species-specific epitopes are present due to an incomplete sequence identity.

Specific IgE measurements to CCD marker molecules such as MUXF can be used to confirm the presence of CCD-sIgE antibodies as reason of multiple positive test results. However, since CCD-sIgE and allergen-sIgE might be present, the detection of CCD-sIgE alone does not allow the exclusion of sensitization to protein epitopes of multiple venoms.

CRD using CCD-free individual allergens is recommended: (A) In case of multiple positive test results with different venoms to discriminate between true sensitization and cross-reactivity. (B) For diagnosis in patients with inconclusive patient history to identify the

culprit insect(s). (C) In case of negative test results with different venoms despite a convincing clinical history due to potentially enhanced sensitivity of the CRD.

The allergens Api m 1, Api m 3, Api m 4 and Api m 10 can be considered as marker allergens for genuine HBV sensitization. Together with marker allergens for vespid venom sensitization Ves v 1 / Pol d 1 and Ves v 5 / Pol d 5 they are useful tools to elucidate primary sensitization, particularly in patients with double-positive test results who were not able to identify the culprit insect or in cases of inconsistent clinical history and test results with venom extracts. Due to the limited cross-reactivity between CCD-free recombinant Api m 2 and its vespid homologues, Api m 2 may contribute as marker allergen to detect primary HBV sensitization. However, as cross-reactivity and, hence, primary sensitization to vespid venom cannot be excluded with absolute certainty, Api m 2-sIgE has to be interpreted with care and seen in the context of clinical history. This is of particular importance as the vespid homologues and thus comparative sIgE measurements are not available for clinical routine diagnostics. Due to the extended cross-reactivity between Api m 5 and its vespid homologues, sIgE to Api m 5 cannot be considered as reliable marker for primary HBV allergy. However, sIgE to Api m 5 can be a confirmatory marker in patients with double-positive skin tests and/or sIgE to HBV and YJV/ PDV, who have an indicative history of HBV allergy. Again, the vespid homologues are not available for comparative measurements in clinical routine. A diagnostic algorithm for the interpretation of sIgE test results in CRD to discriminate between primary HBV and vespid venom allergy or to prove true primary sensitization to different venoms is given in (Figure 131). To date, no individual BBV allergens are available for routine diagnostics.

Cellular tests:

When skin tests and sIgE measurements yield negative results in patients with a systemic anaphylactic reaction, additional cellular tests, such as basophil activation, are recommended and have shown additional benefits when used together with allergen components (for more detailed information about cellular tests please refer to the chapters about vespid venom allergy and basophil activation testing).

Sting challenge:

A sting challenge with a living insect is not recommended as diagnostic tool in untreated patients and should serve only as control of success of venom immunotherapy. For more detailed information refer to the vespid venom chapter.

Prevention and Therapy

Avoidance of bee stings:

Although some behavioral rules exist that might contribute to minimizing the existing risk, avoiding stings completely is challenging. These rules include: avoidance of perfumes and floral or bright colored clothing, careful outdoor eating and drinking, wearing shoes outside, avoidance of swatting to bees, keeping windows of the vehicle closed and staying away from beehives.

Pharmacotherapy (emergency kit):

Due to the risk of severe reactions, patients allergic to bee venom should carry an emergency kit including an adrenaline autoinjector

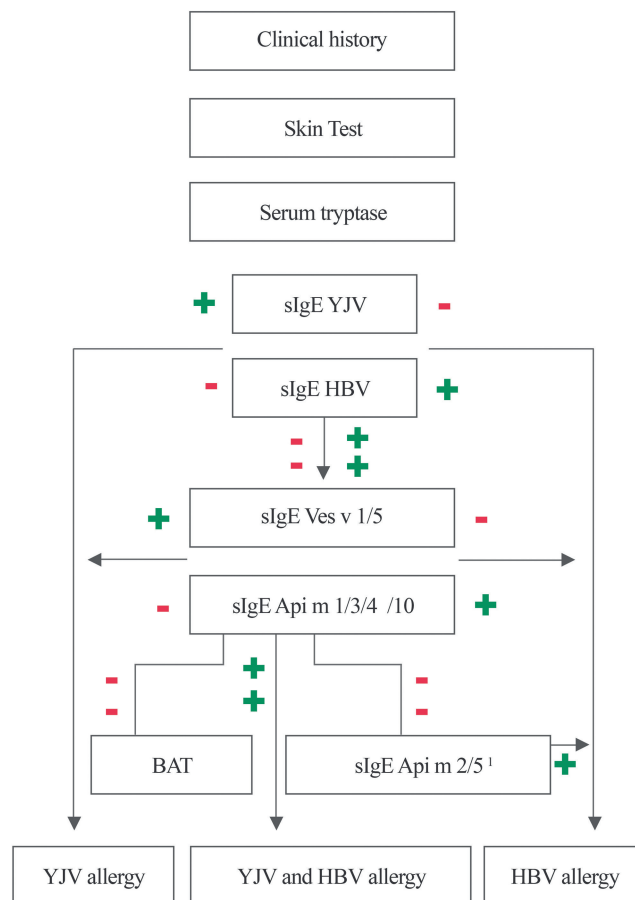


FIGURE 131 Diagnostic algorithm for component-resolved diagnostics of honeybee venom (HBV) and yellow jacket venom (YJV) allergy. This algorithm can also be used to discriminate between HBV and *P. dominula* venom (PDV) allergy using the PDV homologues of Ves v 1 and Ves v 5, Pol d 1 and Pol d 5. A plus indicates a positive and a minus a negative test result. ¹ The HBV allergens Api m 2 and Api m 5 show potential cross-reactivity to homologous allergens of YJV and PDV that are not commercially available, so that a positive test result does not necessarily exclude YJV or PDV allergy. Despite the potential of component-resolved diagnostics, clinical history, skin tests and the measurement of venom-sIgE and serum tryptase build an indispensable basis for accurate diagnosis in Hymenoptera venom allergy. Moreover, cellular tests such as basophil activation test (BAT) may be helpful in dissecting double-positive or double-negative test results.

for self-administration, especially during the bee season. Although, this is a highly debated issue, according to current guidelines, also patients with previous severe allergic reactions who have successfully undergone immunotherapy are recommended to carry an emergency kit to eliminate a remaining risk.

Specific immunotherapy:

HBV VIT is recommended in children and adults with documented sensitization to HBV either by skin test and/or sIgE tests and a history of a systemic sting reaction exceeding general skin symptoms as well as in adults with generalized skin symptoms if quality of life is impaired. VIT is not indicated when neither skin testing nor sIgE indicate a sensitization nor for patients with large local

or unusual reactions.¹²⁸⁵ In addition, incidental positive sIgE results in a multiplex test are not an indication for VIT without relevant clinical history of a systemic sting reaction.

HBV also seems to be sufficient in nonprofessionally exposed BBV-allergic patients who most likely react on the basis of cross-reactivity and a primary sensitization to HBV. By contrast, in heavily exposed greenhouse workers who are frequently stung by bumblebees a VIT with BBV would be preferable.¹²⁷⁴ However, BBV routine therapeutic intervention is commercially not generally available and such approaches have only been reported in case reports. The success of specific immunotherapy may be monitored by a sting challenge test with a live insect (see also chapter B21).

Tips for the use of molecular diagnostics for honeybee venom allergy

- Api m 1, Api m 3, Api m 4 and Api m 10 are marker allergens to detect primary sensitization to honeybee venom (to dissect honeybee and vespid venom allergy).
- Exceptions: No marker allergens are available to discriminate between primary honeybee and bumblebee venom allergy.
- sIgE to Api m 1, Api m 3, Api m 4 and Api m 10 indicates primary bee venom allergy.
- sIgE to Api m 2 may be a helpful marker to detect primary bee venom allergy. Interpret results with care in the context of clinical history.
- sIgE to Api m 5 does not exclude primary vespid venom allergy.

5 – Clinical cases

Case 1 (original)

History: Female, 40 years old, stung by unidentified insect in tip of the middle finger of the right hand. Within minutes generalized itching and urticaria, dyspnea and a feeling of tightness in the throat. Care by an emergency physician.

Skin prick test: HBV (100 µg/mL) and YJV venom (300 µg/mL) positive.

In vitro testing (conventional): tIgE 18.6 kU/L, sIgE to HBV 6.9 kU/L, sIgE to YJV 1.3 kU/L, baseline tryptase 6.3 µg/L.

In vitro testing (molecular): sIgE to rApi m 1 5.7 kU/L, sIgE to rApi m 2 <0.1 kU/L, sIgE to Api m 3 <0.1 kU/L, sIgE to Api m 10 1.7 kU/L, sIgE to rVes v 1 <0.1 kU/L, sIgE to rVes v 5 <0.1 kU/L, sIgE to CCD (MUXF3) 2.4 kU/L.

Diagnosis: Sting anaphylaxis with HBV sensitization, cross-reactivity to YJV likely due to CCD-sIgE.

Recommendation: VIT with HBV extract, emergency kit with adrenaline autoinjector.

Case 2 (original)

History: Male, 52 years old, history of 3 episodes of severe anaphylactic reactions (1 after a honeybee sting and 2 after yellow jacket stings).

Intradermal skin test: HBV (0.001 µg/mL) and YJV (0.01 µg/mL) positive.

In vitro testing (conventional): tIgE 15 kU/L, sIgE to HBV <0.1 kU/L, sIgE to YJV 1.1 kU/L, baseline tryptase 18.9 µg/L.

In vitro testing (molecular): sIgE to rApi m 1 <0.1 kU/L, sIgE to rApi m 2 <0.1 kU/L, sIgE to rApi m 3 1.28 kU/L, sIgE to rApi m 10 0.37 kU/L, sIgE to rVes v 1 1.99 kU/L, sIgE to rVes v 5 1.53 kU/L, sIgE to CCD (MUXF3) <0.1 kU/L.

Diagnosis: Sting anaphylaxis with HBV and YJV sensitization, elevated baseline serum tryptase.

Recommendation: VIT with HBV and YJV extracts, emergency kit with adrenaline autoinjector.

Case 3 (original):

History: Male, 45 years old, stung by an unidentified insect in the neck, within minutes generalized itching, dyspnea, loss of consciousness. Care by an emergency physician.

Skin prick test: HBV (100 µg/mL) and YJV (100 µg/mL) positive.

In vitro testing (conventional): tIgE 360 kU/L, sIgE to HBV 23.6 kU/L, sIgE to YJV 4.3 kU/L, baseline tryptase 3.1 µg/L.

In vitro testing (molecular): sIgE to rApi m 1 10.9 kU/L, sIgE to rApi m 2 2.51 kU/L, sIgE to Api m 3 <0.1 kU/L, sIgE to Api m 5 2.31 kU/L, sIgE to Api m 10 <0.1 kU/L, sIgE to rVes v 1 <0.1 kU/L, sIgE to rVes v 5 7.4 kU/L, sIgE to CCD (MUXF3) <0.1 kU/L.

Diagnosis: Sting anaphylaxis with HBV and YJV sensitization.

Recommendation: VIT with HBV and YJV extracts, emergency kit with adrenaline autoinjector.

6 – Research and future perspectives

The increasing knowledge of the identity of relevant Hymenoptera venom allergens and the availability of their recombinant CCD-free counterparts has led to the development of an advanced CRD in venom allergy. The currently available CRD is a valuable tool to resolve cross-reactivity and primary sensitization; particularly to discriminate between HBV and vespid venom allergy. At this stage, a limitation of CRD in clinical routine is the unavailability of homologous allergen pairs from HBV and vespid venoms that would allow comparative sIgE measurements facilitating the evaluation of obtained test results.

Modern molecular allergology may pave the way towards novel future diagnostic and therapeutic techniques such as the use of recombinant allergens for skin testing or VIT, even though these options may not become available for clinical practice in the near future due to high regulatory demands for this kind of applications.

Additionally, there is some evidence that some allergens and patients' sensitization profiles may act as biomarkers to identify

particular risk factors in venom allergy. However, further prospective studies are crucial to verify whether allergens such as Api m 4, Api m 10 or others are reliable markers to predict severe side-effects during VIT and/or an elevated risk for treatment failure in bee venom allergy.

Nevertheless, the ongoing identification and characterization of Hymenoptera venom allergens as well as the growing availability of allergens for CRD will open new perspectives for accurate and personalized patient management and, hence, for precision medicine in Hymenoptera venom allergy.

B21 – Wasp Venom Allergy

Maria Beatrice Bilò, Thilo Jakob, Markus Ollert, Simon Blank

Highlights

- In yellow jacket venom allergy, CRD is a valuable tool since the diagnostic sensitivity of a combination of the recombinant allergens rVes v 5 and rVes v 1 is very high. In addition, rVes v 5 and rVes v 1 are marker allergens for vespid venom sensitization and allow an excellent discrimination between honeybee and vespid venom sensitization in double-sensitized patients.
- Among paper wasp allergens, Pol d 5 is currently available for routine diagnosis of paper wasp venom allergy on most common sIgE singleplex platforms, while Pol d 1 is exclusively available on multiplex platforms.
- CRD currently offers only limited value in case of double/multiple positivity to vespid venoms. Currently, there are no marker allergens available that allow discrimination between yellow jacket and *Polistes* venom sensitization.
- There are no marker allergens available that allow discrimination between primary yellow jacket and hornet venom sensitization.
- Together with a better knowledge of the molecular composition of different venom extracts and more recombinant vespid allergens available, CRD may contribute to optimize patient-tailored immunotherapy.

1 – The allergen sources

The Vespidae family is composed of the Vespinae subfamily, including the genera *Vespula* (*V. germanica*, *V. vulgaris*, *V. pensylvanica*, *V. maculifrons*, *V. flavopilosa*, *V. squamosa*, *V. vidua*), *Dolichovespula* (*D. maculata*, *D. arenaria*, *D. saxonica*, *D. media*), and *Vespa* (*V. crabro*, *V. orientalis*, *V. velutina nigrithorax*, *V. magnifica*, *V. mandarina*) and the subfamily *Polistinae*, which includes the genus *Polistes* (*P. dominula*, *P. gallicus*, *P. exclamans*, *P. annularis*, *P. fuscatus*), and *Polybia* (*P. paulista*, *P. scutellaris*) (Figure 132). The *Formicidae* family contains the allergy-relevant stinging ant species *Solenopsis spp.*, *Myrmecia pilosula* and *Pachycondyla chinensis*, which are not covered by this chapter.

Vespula (called wasps in Europe, yellow jackets in the USA) are the most important species in Europe (Figure 132). In southern Europe, in addition to *Vespula*,¹²⁸⁶ hornets are a frequent cause of allergic reactions (genus *Vespa*), including the most widespread species *Vespa crabro*. In 2005, *Vespa velutina nigrithorax*, which is from Southeast Asia, was detected in the South of France. *Vespa velutina* is a predator of bees and is rapidly spreading from France to neighboring countries. Anaphylactic reactions have been reported after *Vespa velutina* stings, with a variable degree of cross-reactivity with other vespids.¹²⁸⁷

The species *Polistes dominula* and *Polistes gallicus* are European paper wasps; *P. dominula* has also spread to the northeastern United

States and also been reported in Australia (Figure 133). The species *Polistes exclamans*, *Polistes annularis* and *Polistes fuscatus* are indigenous to North America and not present in Europe. Several of the European species of the vespidae family differ from those found in the USA. Furthermore, popular names for vespids in the USA and Europe are different and may lead to confusion (Table 61).

The vespids and apids other than honeybee have stingers, which usually can be extracted from their victims, thus enabling them to sting several times consecutively.

2 – Allergen families and allergenic molecules

Vespid venoms are complex mixtures of powerful allergens and pharmacologically active compounds, primarily made up of proteins. An overview of the Vespoidea venom allergens, which are presently listed in the WHO/ IUIS allergen nomenclature official database, is given in Table 62.

The main marker allergens for yellow jacket (*Vespula vulgaris*–VV) and European paper wasp (*Polistes dominula*) sensitization have been identified in phospholipase A1 (PLA1) (Ves v 1 and Pol d 1) and antigen 5 (Ves v 5 and Pol d 5), respectively (Figures 134 and 135). PLA1 and antigen 5 have been described as relevant venom allergens also in hornets.

The PLA1 allergens of different *Vespula* species among the *Paravespula* genus share sequence identity of approximately 95% and are thought to be almost completely cross-reactive, while sequence identity is around 70% with the American species *V. squamosa* and *V. vidua* belonging to a different subgenus.¹²⁸⁸ Sequence identity between yellow jacket venom (YJV) PLA1 Ves v 1 and hornet venom Vesp c 1 is around 71%. In summary, all PLA1s are structurally similar and cross-reactivity can be observed between PLA1s of most Vespoidea species,^{1289,1691,1692} making their use difficult for discrimination between allergies to these species. Although catalyzing a related enzymatic reaction, vespid PLA1 allergens share neither sequence identity nor structural similarity with PLA2 allergens from bee venoms. Therefore, PLA1 and PLA2 represent marker allergens that allow discrimination between primary vespid and bee venom sensitization.

As PLA1, antigen 5 (Ag5) allergens are highly abundant proteins in most Vespoidea venoms, belonging to the CAP (cysteine-rich secretory proteins, antigen 5, and pathogenesis-related 1 proteins) superfamily, even though their function within the venom remains largely unclear. While Ag5 sensitization represents a clear marker for vespid venom allergy, the Ag5 allergens of various Vespoidea species display pronounced structural similarity and cross-reactivity in specific IgE (sIgE) measurements as well as using BAT,²¹³ thus preventing them to differentiate between allergies to these species. On the other hand, CAP inhibition and immunoblotting-based studies showed that those techniques remained inconclusive in about 50% of patients with systemic reactions by European hornet stings, suggesting that sensitization against hornet Ag5 is relevant and genuine at least in a subgroup of patients.¹²⁹⁰

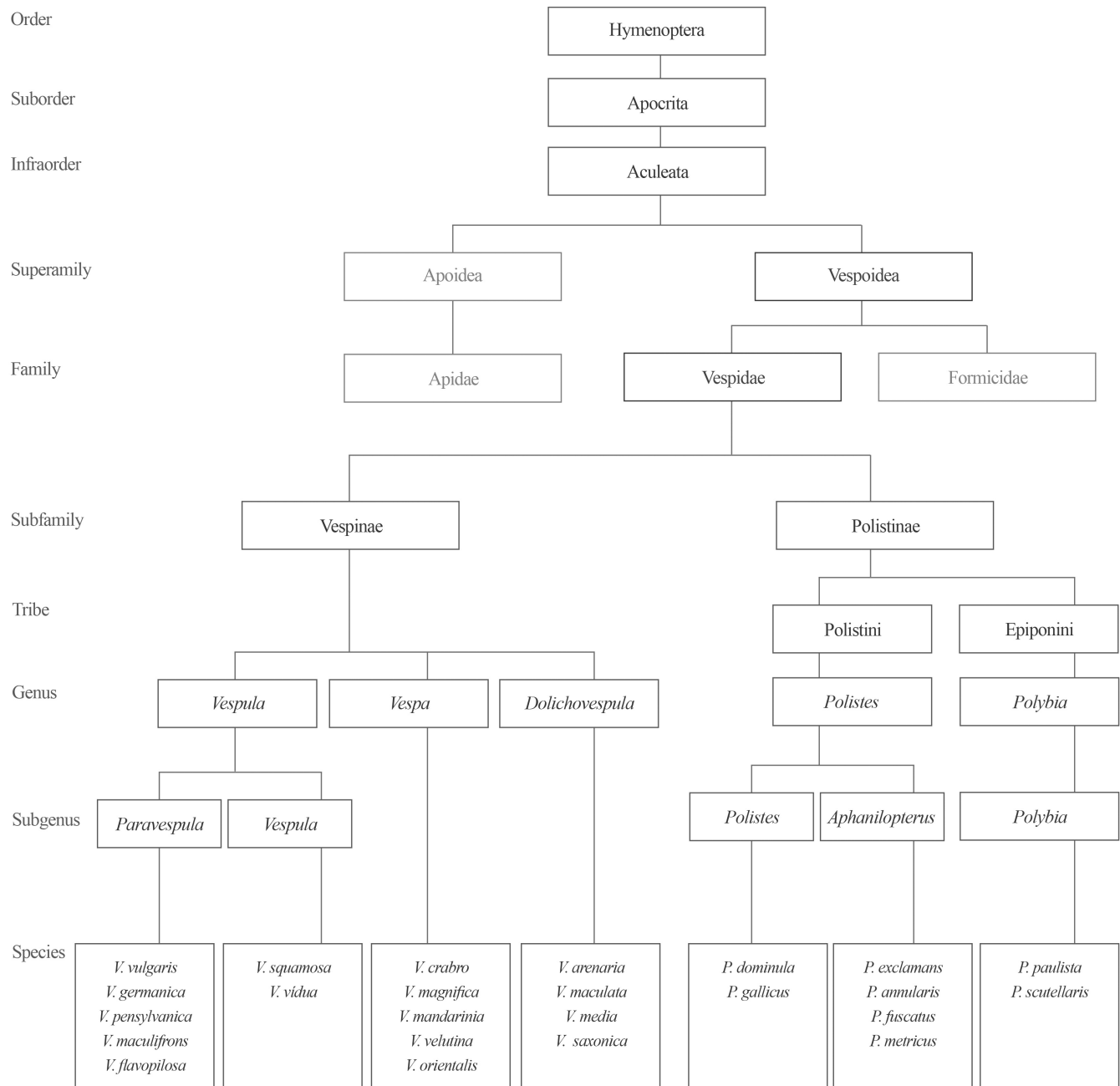


FIGURE 132 Taxonomy of allergy-relevant vespid species. As the taxonomy of the order Hymenoptera is highly complex, only a selection of allergy-relevant taxa is shown. Only selected species with particular relevance for allergy are included. For taxonomic overview of allergy-relevant bees (Apidae) refer to the bee venom chapter. The family Formicidae (ants) also contains species with relevance for Hymenoptera venom allergy.

Hyaluronidases are common components of vespid venoms (e.g., Ves v 2 and Pol d 2). In YJV an enzymatically active (Ves v 2.0101) and an inactive (Ves v 2.0201) hyaluronidase were identified that share sequence identity of 59%, whereby the latter seems to be the predominant isoform.¹²⁹¹ The extent of cross-reactivity between YJV hyaluronidases and their homologue of *P. dominula* venom (Pol d 2) so far remains elusive. By contrast, cross-reactivity between vespid hyaluronidases (Ves v 2, Pol d 2) and honeybee venom (HBV) hyaluronidase (Api m 2) beyond cross-reactive carbohydrate (CCD) reactivity seems to be limited (Figure 136) (see chapter B20).

Significant progress has been achieved mainly by proteomic approaches in identifying important allergens of low abundance. The genes of the 100 kDa dipeptidyl peptidases IV (DPPIV) from YJV (Ves v 3) and *Polistes dominula* venom (Pol d 3), a new class of homologous and cross-reactive Hymenoptera venom enzymes, were identified.^{214,1293} While in YJV DPPIV catalyzes the reaction from promastoparan to mastoparan,¹²⁹² the substrate of *Polistes dominula* venom (PDV) DPPIV remains unclear (the insects probably protect themselves against toxic effects of the peptide substrates). Ves v 3 and Pol d 3 share sequence identity of 76%, resulting in

FIGURE 133 The yellow jacket and the paper wasp



TABLE 61 Vespid species in the USA and Europe

Genus	Species	Popular name	
		Europe	USA
Polistes	Gallicus	Wasp	Annularis
	Dominula		Fuscatus Exclamans
Vespula	Vulgaris	Wasp	Vulgaris
	Germanica		Germanica
	Rufa		Maculifrons
Dolichovespula	Media	Wasp	Maculata
	Saxonica		Arenaria
Vespa	Crabro	European Hornet	Crabro
	Orientalis		
	Velutina nigrithorax		

extensive cross-reactivity.²¹⁴ Additionally, DPPIV allergens of vespid venoms exhibit high cross-reactivity with HBV DPP IV (Api m 5) (Figure 136) and are therefore of no diagnostic value to discriminate between genuine VV and HBV sensitization. The same holds true for the 200 kDa vitellogenins Api m 12 and Ves v 6, that were described as novel pair of highly cross-reactive pan-allergens of HBV and VV¹²⁹³. Other less studied allergens such as serine protease (Pol d 4) of PDV might represent additional marker allergens,¹²⁹⁴ but clinical data supporting this claim are still missing. Moreover, a recent study elucidated the venomes of *P. dominula* and *Vespula spp.* (*V. germanica*, *V. vulgaris*) and identified new allergen candidates such as icarapin-like protein and phospholipase A2.¹²⁹⁵

3 – Sensitization to individual molecules and their clinical relevance

Reliable data on sensitization rate are available for many vespid allergens with different values (Table 63). In fact, these sensitization rates depend on many factors, like the test used for IgE detection, the inclusion criteria of the assessed patient population, an unambiguous identification of the allergy-eliciting insect by the patient as well as geographical differences. Moreover, differences can be observed in mono-sensitized (MS) and double-sensitized (DS) patients, as sensitization rates to individual HBV and YJV allergens are

lower in patients MS to the respective venoms compared with HBV/YJV-DS patients.⁸⁷

IgE sensitization to YJV Ves v 1 ranges between 39% and 66% in different populations of YJV-allergic patients,^{87,1283,1296-1298} and is higher in YJV/HBV-DS compared with YJV-MS patients.⁸⁷

Sensitization to Ves v 5 has been found in 82% to 98% of patients with a history of YJV allergy.^{87,213,1296-1302,1304} Sensitization to Ves v 2 was reported only in 5-25% of YJV allergic patients and mostly directed against the cross-reactive carbohydrate determinants (CCD). The IgE protein reactivity was mostly directed against the enzymatically inactive isoform Ves v 2.0201.¹³⁰³ Sensitization to Ves v 3 and Ves v 6 is less investigated but was found in 57% and 39% of YJV allergic patients, respectively.¹²⁹³

Concerning diagnostic sensitivity, the addition of Ves v 1 to Ves v 5 increased sensitivity of CRD of YJV allergy in the range of 4% to 11% depending on the study populations.^{1296-1300, 1302,1304} Since both rVes v 5 and rVes v 1 are commercially available for diagnostic purposes, in YJV allergy CRD is valuable and can be used to exclude unspecific sensitization due to cross-reactive carbohydrate determinants (CCDs).

Nevertheless, rVes v 1 and 5 failed to diagnose 2-8% of subjects with established allergy¹³⁰⁰, thus probably indicating the need to add more allergens.

The sensitization rate to Pol d 1 was found to be 87% in a Spanish population of PDV/YJV-DS patients.¹²⁸⁹ More recently, Pol d 1 has

TABLE 62 Overview of the Vespoidea venom allergens, which are presently listed in the WHO/IUIS allergen nomenclature official database

Allergenic molecule	Biochemical name	Molecular weight (kDa)
American paper wasps (<i>Polistes annularis</i> , <i>P. exclamans</i> , <i>P. fuscatus</i> , <i>P. metricus</i>)		
Pol a 1, Pol e 1	Phospholipase A1	34
Pol a 2	Hyaluronidase	38
Pol e 4	Serine protease	33
Pol a 5, Pol e 5, Pol f 5, Pol m 5	Antigen 5	23
Asian needle ant (<i>Pachycondyla chinensis</i>)		
Pac c 3	Antigen 5	23
Australian jumper ant (<i>Myrmecia pilosula</i>)		
Myr p 1	Pilosulin-1	7.5/5.5
Myr p 2	Pilosulin-3	8.5/2-4
Myr p 3	Pilosulin-4.1	8.2
European paper wasps (<i>Polistes dominula</i> , <i>P. gallicus</i>)		
Pol d 1, Pol g 1	Phospholipase A1	34
Pol d 2	Hyaluronidase	50
Pol d 3	Dipeptidyl peptidase IV	100
Pol d 4	Serine protease	33
Pol d 5, Pol g 5	Antigen 5	23/24
Fire ants (<i>Solenopsis invicta</i> , <i>S. geminata</i> , <i>S. richteri</i> , <i>S. saevissima</i>)		
Sol i 1	Phospholipase A1	18
Sol i 2, Sol g 2, Sol r 2, Sol s 2	Unknown	14/13/13/13
Sol i 3, Sol r 3	Antigen 5	26/24
Sol g 3, Sol s 3	Unknown	24
Sol i 4, Sol g 4	Unknown	12
Hornets (<i>Vespa crabro</i> , <i>V. magnifica</i> , <i>V. mandarinia</i> , <i>V. velutina</i>)		
Vesp c 1, Vesp m 1, Vesp v 1	Phospholipase A1	34/34/36
Vesp ma 2	Hyaluronidase	35
Vesp c 5, Vesp ma 5; Vesp m 5, Vesp v 5	Antigen 5	23/25/23/23
Polybia wasps (<i>Polybia paulista</i> , <i>P. scutellaris</i>)		
Poly p 1	Phospholipase A1	34
Poly p 2	Hyaluronidase	33
Poly p 5, Poly s 5	Antigen 5	23/21
Yellow hornet, White-faced hornet (<i>Dolichovespula arenaria</i> , <i>D. maculata</i>)		
Dol m 1	Phospholipase A1	34
Dol m 2	Hyaluronidase	42
Dol a 5, Dol m 5	Antigen 5	23
Yellow jackets (<i>Vespula vulgaris</i> , <i>V. flavopilosa</i> , <i>V. germanica</i> , <i>V. maculifrons</i> , <i>V. pennsylvanica</i> , <i>V. squamosa</i> , <i>V. vidua</i>)		
Ves v 1, Ves m 1, Ves s 1	Phospholipase	34
Ves v 2.0101, Ves m 2	A1 Hyaluronidase	45/46
Ves v 2.0201	Hyaluronidase (inactive)	45
Ves v 3	Dipeptidyl peptidase IV	23
Ves v 5, Ves f 5, Ves g 5, Ves m 5, Ves p 5,	Antigen 5	
Ves s 5, Ves vi 5		200
Ves v 6	Vitellogenin	

been demonstrated as the most frequent *Polistes* allergen in Italian allergic patients. In fact, Pol d 1 sensitization was present in 97% (DS) to 100% (MS) of 128 PDV-positive patients. Moreover, it was frequently involved in case of positivity to a single PDV allergen

(48% in DS and 80% in MS patients), and it was positive in 95% of Pol d 5-negative subjects.¹³⁰⁵

Sensitization to Pol d 5 was found in 69-72% of Spanish PDV/YJV-DS patients, while it was observed in 53% and 20% in the DS

FIGURE 134 Annotated allergens of yellow jacket (*Vespula vulgaris*) and European paper wasp (*Polistes dominula*) venom. Only selected allergens with proven high relevance are depicted. Allergens from the same protein family are shown in identical colors.

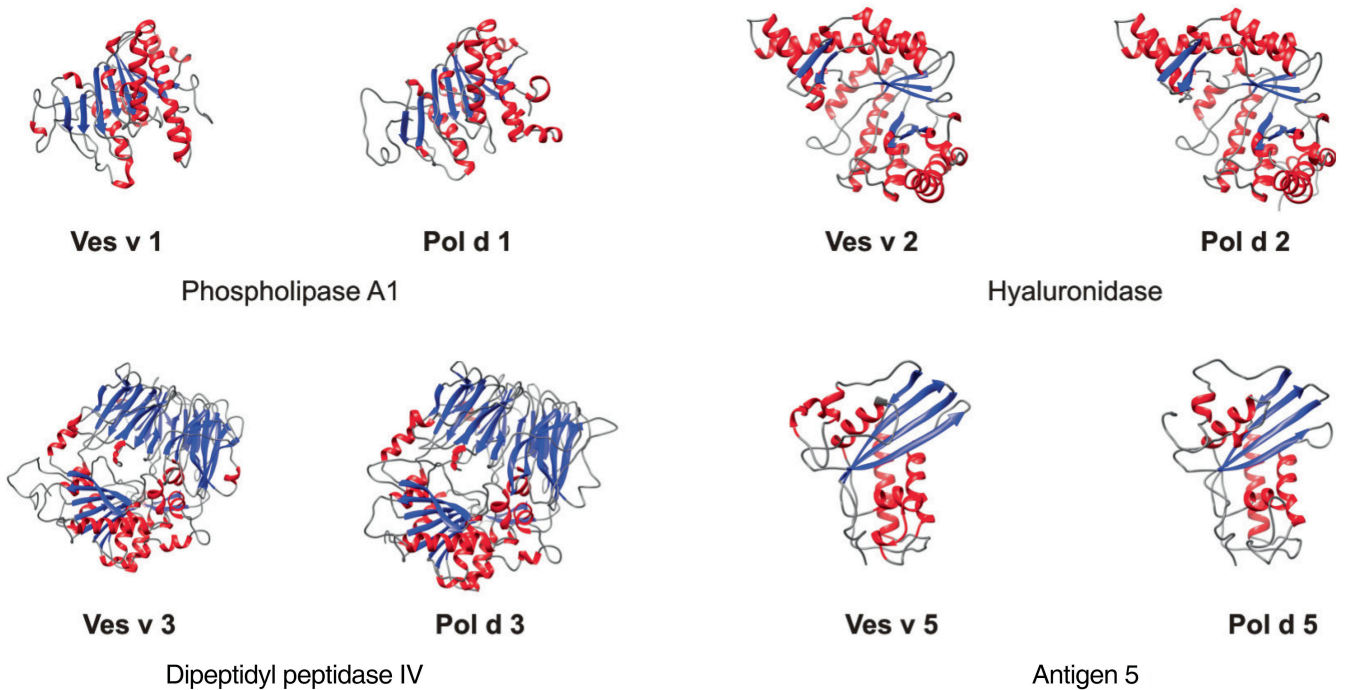
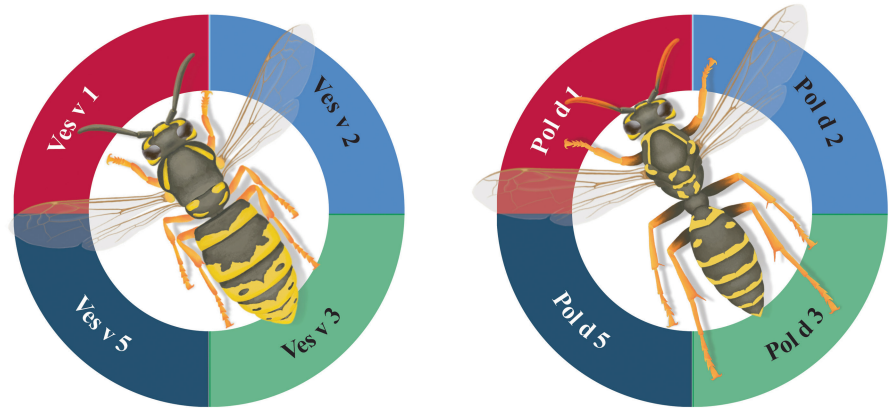


FIGURE 135 Structures of selected vespid venom allergens. Structures were generated by either X-ray diffraction or structural modelling. α -helices, β -strands and coiled regions are shown in red, blue, and grey, respectively.

and MS Italian group, respectively.¹³⁰⁵ Less is known about sIgE sensitization to Pol d 2.

Preliminary unpublished data suggest a sensitization rate of approximately 25% in PDV-allergic patients.¹³⁰⁶ Primary sensitization to Pol d 2 may induce cross-reactivity with Api m 2 and Ves v 2.0201. However, only very few Api m 2-reactive patients show sIgE to Pol d 2.

Sensitization to Pol d 3 is less investigated but was found in 66% of PDV-allergic patients, respectively.²¹⁴ In the South of Europe double sensitization to either *Vespula* or *Polistes* species is more frequent than that of *Vespula* and honeybee.^{1307,1308} Although *Polistes* venom is devoid of CCDs,¹³⁰⁹ a definite discrimination may be difficult due to the high degree of cross-reactivity between the major

allergens of these venoms and to the absence of marker allergens available²¹³ (Figure 137).

Finally, no data are available on the correlation between certain molecular sensitization profiles to vespid allergens and severity of the sting reaction, increased risk of VIT failure (during or after its discontinuation) or of side effects.

4 – Clinical management

Clinical diagnosis

The goal of vespid allergy diagnostics is to classify the type of reaction, to confirm an IgE-mediated pathogenesis, and to identify

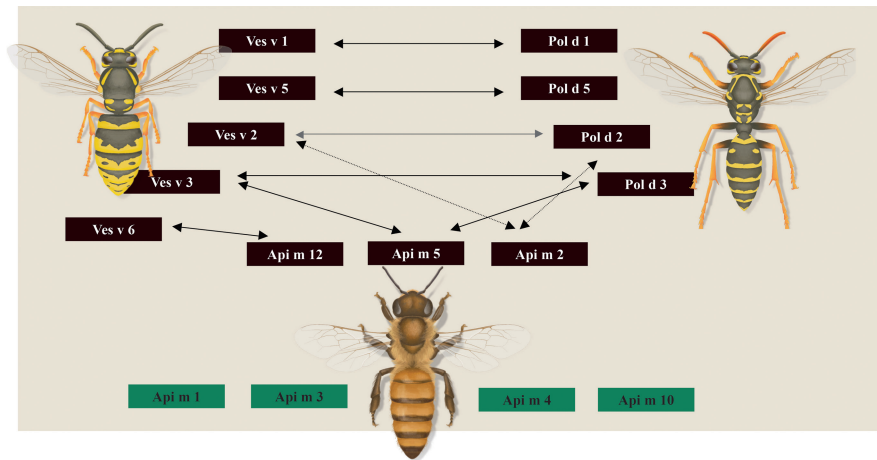


FIGURE 136 Cross-reactivity of vespid allergens and their homologues from honeybee venom. Potentially cross-reactive and marker allergens for the discrimination between primary vespid venom and honeybee venom allergy are shown in black and green, respectively. Of note, vespid phospholipases A1 (Ves v 1 and Pol d 1) and antigens 5 (Ves v 5 and Pol d 5) can serve as marker allergens to discriminate between vespid and honeybee venom allergy but are highly cross-reactive among each other. Black solid arrows: highly cross-reactive; black dotted arrows: limited cross-reactivity; grey arrows: cross-reactive, but detailed studies on its degree are missing.

TABLE 63 Sensitisation rates to individual yellow jacket venom allergens and *Polistes dominula/annularis* venom allergens

Allergenic molecule	Biochemical name	Sensitisation rate (%)	Molecular weight (kDa)
Ves v 1	Phospholipase A1B	39–66 ^{87, 1283, 1296–1298}	34
Ves v 2	Hyaluronidase	5–25 ¹³⁰³	45
Ves v 3	Dipeptidyl peptidase IV	57 ¹²⁹³	100
Ves v 5	Antigen 5	82–98 ^{87, 213, 1296–1302, 1304}	23
Ves v 6	Vitellogenin	39 ¹²⁹³	200
Pol d 1	Phospholipase A1	87 (nPol d 1) ¹²⁸⁹ 97–100 (rPol d 1) ¹³⁰⁵	34
Pol d 3	Dipeptidyl peptidase IV	66 (rPol d 3) ²¹⁴	33
Pol d 5	Antigen 5	69–72 (nPol d 1) ¹²⁸⁹ 20–53 (rPol d 1) ¹³⁰⁵	23
Pol a 5	Antigen 5	44 (r Pol a 5) ¹²⁸⁹	

the culprit insect. Currently it is based on clinical history, skin tests and measurement of sIgE antibodies to vespid venom.¹²⁷⁵

As venom sensitization is found in up to 40% of history-negative persons, only those with a history of a previous systemic sting reaction (SR) are in general eligible for diagnostic testing.¹²⁷⁵

Patient history:

The patient is asked to describe his/her symptoms and the course of the sting reaction, number of stings, clues as to the type of insect involved and individual risk factors for anaphylaxis.¹²⁸⁶ It may be useful to show the patient an entomological notice board to facilitate the identification of the stinging insect.

Vespiniae and Polistinae subfamilies are very similar, with differences at the junction of the thorax and abdomen. Vespiniae have a truncated junction while Polistinae are more oval in shape. Vespidae are almost hairless and have black and yellow striped abdomens.¹²⁸⁶

In patients with a history of severe SR dermatological evaluation is recommended to rule out a possible diagnosis of cutaneous mastocytosis. In patients with an unclear or suggestive psychosomatic

reaction, scrutiny of emergency room and ambulance records is recommended.¹²⁸⁶

Skin tests:

The sensitivity of skin prick test (SPT) alone is estimated around 64%, while a combination of SPT and intradermal testing (IT) reaches a 94% sensitivity,^{1286,1298} hence it is recommended to perform both tests sequentially.^{1275,1310}

In case of negative skin tests but presence of a suggestive history of SR, cutaneous tests should be repeated after 1–2 months, along with serologic testing.

Standardized Hymenoptera venom products, including YJ and *Polistes* wasp venoms, are commercially available in many countries, being mixtures of the clinically relevant species for YJ (*Vespula vulgaris*, *V. flavopilosa*, *V. germanica*, *V. maculifrons*, *V. pensylvanica*, *V. squamosa*) and American *Polistes* (*Polistes annularis*, *P. exclamans*, *P. fuscatus*, *P. metricus*) venom extracts.

Contrary to the USA, dialyzed bee and yellow jacket venoms are used for diagnosis and therapy in some European countries, allowing different diagnostic accuracy with respect to the use of un-dialyzed

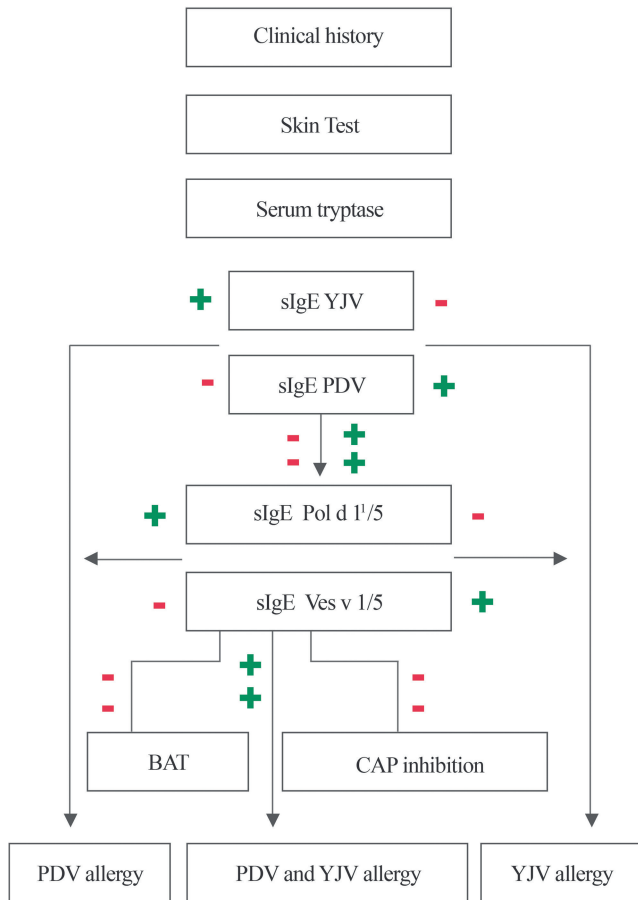


FIGURE 137 Diagnostic algorithm for component-resolved diagnostics of yellow jacket venom (YJV) and European paper wasp venom (PDV) allergy. A red minus indicates a negative and a green plus a positive test results. 1 Pol d 1 is currently only available for a selected multiplex sIgE platform. Despite the potential of component-resolved diagnostics, clinical history, skin tests and the measurement of venoms IgE and serum tryptase build an indispensable basis for accurate diagnosis in Hymenoptera venom allergy. Moreover, cellular tests such as basophil activation test (BAT) and CAP inhibition assays may be helpful diagnostic tools in dissecting primary sensitization.

extracts.¹³¹¹ In dialyzed venom, low molecular weight components (like histamine and components with histamine-releasing activity) smaller than 1000-3000 Dalton are removed. In view of lower cross-reactivity between venoms of the European and American species of *Polistes*¹³¹² commercial preparations of European *Polistes dominula* venom are now available.¹²⁸⁶ Even though a high cross-reactivity between *Vespula* species venom and *V. crabro* has been confirmed, a commercial extract of *Vespa crabro* is also available in some countries.¹³¹³

No recombinant venom allergens are commercially available for skin testing.

IgE testing:

Total IgE - Total IgE (tIgE) determination may be useful for appropriate interpretation of allergen-specific IgE, especially in the case of very low level of sIgE (see also the chapter about bee venom allergy).

Specific IgE to venom extracts and individual venom allergens:

Venom-sIgE can be detected immediately after the sting, but the optimal time point will be 1-4 weeks later.¹²⁷⁵ The sensitivity of conventional YJV sIgE assay using the whole extract ranges between 83.4% and 91%, the newly developed YJV solid-phase assay complemented with rVes v 5 having a higher sensitivity than the traditional YJV test.^{1296,1298}

There is no correlation between the severity of sting reactions and the concentration of venom sIgE to whole venom extracts^{1275,1310} as some patients with minimal or absent venom-sIgE antibodies can develop severe anaphylaxis.¹³¹⁰ According to a recent study, the severity of sting reactions was not associated with results obtained by skin testing, venom-ssIgE levels or even molecular sIgE testing.¹³¹⁴

Of note, negative sIgE and negative skin tests have been reported in the past in up to 15% of patients with systemic mastocytosis and history of a systemic reaction to insect stings,¹³¹⁵ thus, restricting them from VIT. With the introduction of new methods including CRD and parameters of evaluation in the diagnostic work-up, this diagnostic gap has been solved and sIgE can be detected in the vast majority of these patients.^{1297,1316} According to some studies, sIgE levels between 0.1 and 0.35 kUA/l should be considered relevant in patients with a clear clinical history and low levels of tIgE, irrespective of the presence of mast cell diseases.^{1297,1316}

A double *in vitro* positivity to YJV and *Polistes* venom is common in Mediterranean countries, much more frequent than to YJV/PDV and HBV.^{1307,1308} While CRD is able to adequately distinguish allergies to HBV and vespid venom (particularly YJV) (for more detailed information please refer to the bee venom chapter), this is not the case when a differentiation between allergies to various vespid venoms is required (Figure 135).

A previous study demonstrated that the measurement of relative levels of sIgE to the phospholipases A1 (Ves v 1 and Pol d 1) and antigens 5 (Ves v 5 and Pol d 5) of YJV and PDV allowed the identification of the primary sensitizing venom in 67% of double-sensitized allergic patients, while *Vespula* hyaluronidase was shown to have no additional value as regards the specificity of the assay. A subsequent study of a very small patient cohort showed that the detection of sIgE against the same four allergens could determine the correct venom for immunotherapy in the majority but not in all patients.¹³¹⁷ Therefore, the additional availability of these and other (e.g., dipeptidyl peptidases IV) cross-reactive allergens from vespid venoms for CRD would represent an added value for advanced precision diagnostics in venom allergy.¹³¹⁸

According to some studies, the gold standard to resolve double sensitization in PDV and YJV allergy are CAP-inhibition assays with PDV and YJV.¹³¹⁹⁻¹³²¹ Current limitations of the commercially available homologous allergens Pol d 5 and Ves v 5 to distinguish between YJV and PDV allergy in double-positive patients by CRD were demonstrated by the fact that a good accordance between Ag5-based CRD and CAP-inhibition assays can only be achieved when the value of sIgE in kU/L to Ves v 5 is about twice of those to Pol d 5 and vice versa.^{1319,1320} However, a later multicenter study did not

find any agreement between CAP-inhibition test results and double sIgE values of Ves v 5 over Pol d 5 or vice versa.¹³²¹

So far, only the major allergens Ves v 1 (phospholipase A1) and Ves v 5 (antigen 5) of VV and Pol d 5 of PDV are available for routine molecular diagnostics on most commonly used sIgE singleplex assay platform, while Pol d 1 is exclusively available for multiplex testing.

No individual (European) hornet allergens are available for routine diagnostics.

Finally, an incomplete cross-reactivity between European and American paper wasps was demonstrated^{1308,1312} leading to the need to introduce, at least in Europe, the *Polistes gallicus* or *dominula* extract (the latter only being available in some European countries) into clinical practice for diagnostic and therapeutic purposes. The importance of the concept is also underlined by the possibility, as already reported, of lack of protection by immunotherapy with the American *Polistes* species venom mixture in European patients.¹³²² Due to the increasing spread of *Polistes dominula* on several continents, associated diagnostic and therapeutic problems are likely to gain importance in other areas of the world.

For the use of species-specific marker allergens that help to differentiate between HBV and vespid venom allergy, please refer to the chapter on bee venom allergy and the diagnostic algorithm depicted in (Figure 137).

IgE-inhibition test:

IgE-inhibition tests with whole venom extracts can be used in particular cases to detect the primary sensitizing venom in patients double-positive to venoms without marker allergens, e.g., YJV and PDV.^{1319–1321} However, IgE-inhibition tests are costly, time-consuming and results occasionally difficult to interpret.¹³²¹

Cellular tests:

Among cellular tests, basophil activation test (BAT) is the most useful one and can be used as a diagnostic tool in some specific cases, especially if skin tests and sIgE antibodies to insect venom extracts are negative.^{1296,1323} BAT is also recommended in double-positive patients with inconclusive recombinant or skin test double-positive results, especially if the patient has had an anaphylactic reaction to only one insect.¹³²⁴ BAT seems to be useful in monitoring VIT, during the treatment and after its discontinuation.^{1276,1325} For more detailed information about cellular tests please refer to the chapter about basophil activation testing.

Baseline serum tryptase:

It is recommended to determine the tryptase concentration in all patients with a history of a systemic reaction after a Hymenoptera sting. For more details refer to the bee venom chapter.

Sting challenge:

The aim of a sting challenge still remains to verify the induction of tolerance during venom immunotherapy (VIT).¹³²⁶ The significant improvement in health-related quality of life not only after initiation of VIT but especially after a tolerated sting challenge may favor this procedure, which should be performed exclusively under emergency preparedness.

It should be noted that the outcome of sting challenge is influenced by a number of factors, including insect biology, indicating that bees yield more reliable sting challenge results than vespids.

Prevention and Therapy

Preventive measures:

A series of recommendations have been formulated aimed at substantially minimizing the risk of field re-stings, although as yet no evidence-based studies have been performed to support this.

In contrast to previous studies, a recent prospective, observational, multicenter trial, collecting 1,425 patients shows that taking β -blockers or ACEI does not seem to aggravate the severity of insect sting reactions in untreated patients.¹³²⁷

Pharmacotherapy (emergency kit):

All patients with a previous SR due to a Hymenoptera sting should be prescribed an emergency kit (containing an adrenaline autoinjector, H1-antihistamines, and corticosteroids) depending on the severity of their previous reaction(s) and advised to carry it, especially during the Hymenoptera season.¹³²⁸

Self-injectable adrenaline should be considered for all patients with a history of a SR, particularly those who have experienced “moderate-severe” episodes or those with increased risk of future exposure to stings (beekeepers, gardeners, waste management workers etc.), underlying mast cell disorders or raised baseline serum tryptase or other co-morbidities.¹³²⁸

Venom specific immunotherapy (VIT):

According to the European and American Guidelines, subcutaneous venom immunotherapy is the only treatment able to prevent further systemic sting reactions.^{1310,1329}

The effectiveness of honeybee and vespid VIT is different and ranges from 77 to 95% for HBV compared with 91 to 99% for vespid venom.¹³²⁹ The underlying reasons are still unclear. For more detailed information refer to the honeybee venom chapter.

Finally, VIT may benefit venom-allergic patients with mast cell diseases, albeit to a lesser extent than patients without mastocytosis.¹³³⁰

5 – Clinical cases

Case 1 (original)

History: Male beekeeper living in the Mediterranean area, 59 years old, frequently stung, sometimes with large local reaction. Stung by a probable vespid in the neck (no sting was found), within minutes he developed generalized itching and urticaria, dyspnea, nausea, vomiting, and generalized malaise. Care by an emergency doctor.

Intradermal skin test: HBV (0.001 μ g/mL), YJV (1 μ g/mL) and PDV (0.01 μ g/mL) positive.

In vitro testing (conventional): tIgE 180 kU/L, sIgE to HBV 20.6 kU/L, sIgE to YJV 1.2 kU/L, PDV 18.9 kU/L, baseline tryptase 3.2 μ g/L.

In vitro testing (molecular): sIgE to rApi m 1 18.2 kU/L, sIgE to rVes v 1 <0.1 kU/L, sIgE to rVes v 5 0.15 kU/L, sIgE to rPol d 5 16.5 kU/L, sIgE to CCD (MUXF3) <0.1 kU/L (considering the clinical history, sIgE to other HBV recombinant allergens were not measured).

REMA score: negative.

Diagnosis: PDV allergy (anaphylactic reaction), large local reaction to HBV in beekeeper.

Recommendation: VIT with PDV extract, emergency kit with adrenaline autoinjector.

Case 2 (original)

History: Atopic female living in Mediterranean area, 61 years old, stung by an unidentified vespid in the hand with generalized urticaria and angioedema of the eyes and lips, nausea, dizziness; one year later after a sting by an unidentified vespid in the head, reaction with generalized urticaria, nausea, uterine cramps. Care by an emergency physician.

Intradermal skin test: HBV (negative), YJV (0.01 µg/mL) and PDV (0.01 µg/mL) positive.

In vitro testing (conventional): tIgE 850 kU/L, sIgE to honeybee venom <0.1 kU/L, sIgE to YJV 7.7 kU/L, PDV 7.4 kU/L, baseline tryptase 2.1 µg/L.

In vitro testing (molecular): sIgE to rVes v 1 2.8 kU/L, sIgE to rVes v 5 6.5 kU/L, PDV 6.1 kU/L. REMA score: negative.

Diagnosis: PDV and YJV allergy (anaphylaxis).

Recommendation: VIT with PDV and YJV extracts, emergency kit with adrenaline autoinjector.

Case 3 (original)

History: Male living in Mediterranean area, 65 years old, history of 2 episodes of severe anaphylactic reaction (both after a vespid sting, in the head and the leg, respectively; in one case the patient family members identified the nest of a Polistes): both reactions characterized by hypotension and loss of consciousness without skin symptoms. Care by an emergency physician, in the second case hospitalization was required.

Intradermal skin test: HBV (negative); YJV (1 µg/mL) and PDV (1 µg/mL) positive.

In vitro testing (conventional): tIgE 35 kU/L, sIgE to HBV <0.1 kU/L, sIgE to YJV 1.5 kU/L, PDV 1.7 kU/L, baseline tryptase 7.5 µg/L.

In vitro testing (molecular): sIgE to rVes v 5 1.2 kU/L, sIgE to rVes v 1 <0.1 kU/L, sIgE to rPol d 5 1.1 kU/L. REMA score: positive.

Diagnosis: PDV and YJV allergy (anaphylaxis), mastocytosis.

Recommendation: VIT with PDV and YJV extracts, emergency kit with adrenaline autoinjector.

6 – Research and future perspectives

CRD is undoubtedly an innovative diagnostic method that leads to a more precise definition of the sensitization profile of the venom

allergic patient. The use of CRD is indicated in cases of a proven history of a previous SR and negative results in standard diagnostic tests and in patients with polysensitization to different venoms, as it may help the specialist to choose the most suitable venom for VIT (see also chapter on bee venom allergy).

Modern molecular allergology may pave the way towards novel future diagnostic and therapeutic techniques such as the use of recombinant allergens for skin testing or VIT, even though these options may not become available for clinical practice in the near future due to high regulatory demands for this kind of applications.

However, at present, while CRD makes it possible to distinguish between allergy to *Apis mellifera* and allergy to *Vespula* species venoms, the value of CRD is limited in cases of double positivity to *Vespula*-*Polistes*. Thus, new recombinant molecules are needed to improve the diagnosis of *Polistes* allergic patients, especially in the case of double-positivity to both *Polistes* spp. and *Vespula* spp. venom, in order to prevent unnecessary double VIT.

Other limitations of CRD are represented by the incidental detection, as observed for venom extracts, of sIgE sensitization in patients without clinical history of a sting reaction, and by the inability to correlate sIgE levels to venom components with the severity of the sting reaction. We hope that future studies using CRD may identify biomarkers able to distinguish between asymptomatic and symptomatic sensitization, and between different degrees of SR severity, as well as biomarkers for VIT efficacy, VIT tolerance and relapse after discontinuing the treatment.

Advices for the use of molecular diagnostics for vespid venom allergy

- Ves v 1 / Pol d 1 and Ves v 5 / Pol d 5 are marker allergens to detect primary sensitization to vespid venom (to dissect honeybee and vespid venom allergy).
- Exceptions: No marker allergens are available to discriminate between primary sensitization to the different vespid species.
- sIgE to Ves v 1 / Pol d 1 and Ves v 5 / Pol d 5 indicate primary vespid venom allergy.
- sIgE to Ves v 1 / Pol d 1 and Ves v 5 / Pol d 5 is no reliable marker to dissect between primary sensitization to yellow jacket and /or European paper wasp venom.

B22 – Occupational allergy

Monika Raulf

Highlights

- More than 400 occupational sensitizers are identified but only a limited number of them are characterized on the molecular level.
- Natural rubber latex (NRL) allergy is an excellent model for improving sIgE measurement with recombinant major allergens.
- IgE-sensitization profile in patients with baker's asthma showed great inter-individual variation.
- For diagnosis of wheat allergy due to baker's asthma extract-based diagnostic is still recommended.
- Including baking enzymes into the test panel is highly recommended for diagnosis of baker's asthma.
- Asp o 21, alpha-amylase produced in *Aspergillus oryzae*, is commercially available.
- Increasing the knowledge of occupational allergens and implement and evaluate standardized tools in clinical practice is necessary.

1 – The allergen sources and their clinical relevance

More than 400 occupational agents have been identified and documented as being potential “respiratory sensitizers”.¹³³¹⁻¹³³³ They are triggers of occupational rhinitis (OR) and occupational asthma (OA). Development of OA is often preceded by allergic rhinitis. Both OR and OA are serious health problems in industrialized countries estimated to account for 5% to 15% of asthma cases in adults of working age, and the prevention, as well as diagnosis of these diseases is a challenge (Table 64).

OA is distinguished from work-enhanced asthma and reactive airway disease syndrome, which is caused by occupational exposure to airborne irritants. The “respiratory sensitizers” can be divided into high-molecular weight (HMW) and low-molecular weight (LMW)

substances.¹³³⁴⁻¹³³⁶ Typical LMW substances are isocyanates, acid anhydrides, metals, ammonium persulfate, fumes and vapours from detergents, bleaches and fixatives used by hairdressers, disinfectants and pharmaceuticals. In the case of an IgE-mediated mechanism, it is generally assumed that the allergenicity of these LMW or their metabolites is due to a mostly covalent interaction with some carrier proteins to form a hapten-carrier complex. The most common occupational HMW agents are proteins or glycoproteins derived from diverse plants, animals and micro-organisms. They are found in cereal flour, livestock and laboratory animals, mites, fish and seafood, fodder and detergent enzymes, mould (fungi), *Hevea brasiliensis* latex and wood dust. To date, only a few of the HMW agents have been biochemically and molecular characterized or are produced in recombinant form, because most of the respiratory sensitizing properties of the various occupational substances are only documented as individual case reports. Due to this lack of knowledge about allergen components and their allergenicity only a limited number of recombinant or native occupational relevant allergens are currently commercially available for the *in vitro* diagnosis. Crude extracts from the different allergen sources have traditionally been used for the detection of sensitization by specific IgE quantification or by skin prick tests, whereby the composition and amount of an allergenic extract very much influence the results. Unfortunately, standardized reagents are available for only a few occupational allergens.¹³³⁴⁻¹³³⁶

The focus here is on the presentation of examples with the possibilities and application of component-resolved diagnosis (CRD) with occupational allergens, their clinical relevance and their implementation into the *in vitro* diagnosis for occupational allergies.

1.1 Natural rubber latex (*Hevea brasiliensis*)

The milky sap of the rubber tree *Hevea brasiliensis* is the source for the production of commercial natural rubber latex (NRL) devices and represents also a source of potent allergenic proteins.^{4,1337-1340,1693} Most of *Hevea brasiliensis* grows commercially in a number of tropical countries, mainly in Thailand, Indochina, Malaysia and India. The milky sap is synthesized by specialized laticifer cells and collection of the latex is possible by scarifying the trunk of the *Hevea brasiliensis* tree. Ammonia treatment prevents coagulation resulting in

TABLE 64 Examples for typical occupational allergen sources at workplaces

Workplace/ Trade and Industry	Allergen source
Agriculture/farming	Cow dander, pollen, storage mites
Animal feed production	Soy, phytase
Bakery/Mills	Wheat flour, rye flour, different other grain flours, soy flour, α -amylase, xylanase, glucoamylase, storage mites, insects, moulds, spices
Food processing industry	Several cereals, plants, vegetables, fruits and spices, seeds, mushrooms, seafood (shellfish and fish), raw coffee beans, farm products (eggs), food additives, enzymes, food contaminants (e.g. mites, insects, moulds)
Health care facilities	Disinfectants, natural rubber latex
Laboratory animal facilities/Life science faculties of universities	Mouse, rat (urine, dander)
Laundry detergent industry	Enzymes: protease, cellulase, lipase, amylase

hydrolysis of the latex proteins. The main constituent of Hevea latex is the polymeric hydrocarbon 1,4 cis-polyisoprene and only 1-2% of the fresh milky sap is made up of proteins. The proteins are heterogeneously distributed in the latex sap and they are involved in the biosynthesis of the polyisoprene, associated with the coagulation of latex and in the defense of the plant against various diseases. After ultra-centrifugation of the fresh latex sap basically three main fractions (rubber phase, the C-serum and the bottom fraction (B-serum)) are easily discerned (Figure 138).

In the 1980s and into the 1990s, cases of NRL allergy increased dramatically. One factor was the elevated hygiene standards in medicine in response to communicable infectious diseases (especially AIDS), which led to the increased use of NRL products, especially NRL gloves.¹³³⁷ The introduction of powder-free and/or gloves with a low allergen content, the reduction or even ban of powdered NRL gloves in some countries and public health campaigns on prevention have resulted in a significant decrease in NRL allergies, especially in the health care sector. Increasing awareness of the health risk posed by NRL products, particularly among health care workers and also among spina bifida patients undergoing surgery in their first days of life, initiated enhanced research on allergen characterization, quantification and improvement of allergy diagnosis. *Hevea brasiliensis*, the origin of NRL, is one of the best characterized occupational allergen sources.^{4,1337} Up to now about 250 different NRL polypeptides were identified. About 60 are capable to bind human IgE and currently 15 allergens have been included in the latest nomenclature list of the International Nomenclature Committee of Allergens (IUIS) and assigned official numbers (Hev b 1-15). (www.allergen.org) (Table 65).

Hev b 1 together with Hev b 3 are rubber particle proteins. Hev b 5 is an acidic (pI 3.5) and heat-stable 16-24 kDa protein, rich of glutamic acid and of proline residues. The first recombinant Hev b 5 (rHev b 5) was described by Slater et al.¹³⁴¹ Prohevein, Hev b 6.01, was isolated from the B-serum and posttranslational cleavage

proceeds two further proteins, the 4.7 kDa hevein (Hev b 6.02) and the 14 kDa C-terminal domain Hev b 6.03.¹³⁴¹ All three allergens additionally exist in the plant and the ratio between Hev b 6.01 and Hev b 6.03 is about 30:1. Hev b 6.02 (hevein) comprises the most important part of IgE-binding epitopes in the prohevein molecule. In addition, hevein shows homology to several chitin-binding lectin domains¹³⁴² and may be responsible for certain cross-reactivities to several other plants and food. Most of the Hev b proteins have been cloned and expressed as recombinant proteins. Sequencing demonstrated both unique epitopes and sequences commonly found in other plant proteins. Sequence homology helps to explain the cross-reactivity to a variety of foods experienced by latex allergic individuals.

Studies demonstrated that various risk groups like patients with spina bifida (SB) and occupational latex exposed health care workers (HCWs) are sensitized by different NRL allergens¹³⁴³⁻¹³⁴⁵ based on the different route of exposure (direct blood contact versus inhalation) or as also shown in differences in the allergen levels measured between internal and external surfaces of NRL gloves.¹³⁴⁶ In the case of health care workers suffering from occupational latex allergy the most important NRL allergens are Hev b 5 and Hev b 6.01 or Hev b 6.02, respectively. Other NRL allergens like Hev b 1 or Hev b 3 often recognized by specific IgE of spina bifida patients are only minor allergens in latex allergic health care workers.¹³⁴³ About 30-50% of latex-allergic patients show allergic symptoms to plant-derived foods, especially fresh fruits.¹¹⁶⁹ The association was called latex-fruit syndrome (review in¹³⁴⁷) and huge amounts of relevant fruits, constantly increasing, are described and the most commonly involved are avocado, banana, chestnut, and kiwi. Several latex allergens were discussed as responsible for the latex-fruit cross-reactivity (Figure 139), such as Hev b 2,¹³⁴⁸ Hev b 6.02,¹³⁴⁹⁻¹³⁵¹ Hev b 7,¹³⁵² Hev b 8 and Hev b 12.¹³⁵³

In some cases, the use of recombinant single latex allergens for NRL-specific IgE mapping was helpful to discriminate between cross-reactivity and co-sensitization of latex and fruits.^{1354,1355} Especially in plant allergens like NRL, grass pollen¹³⁵⁰ or wood allergens¹³⁵⁶ and also in insect venoms⁴⁵⁹ the presence of cross-reactive carbohydrate determinants (CCDs) can negatively influence the specificity of the *in vitro* diagnostic test. Therefore, it is necessary to exclude glyco-epitopes (with low clinical relevance) responsible for IgE binding. Corresponding CCD screening tools (e.g., horseradish peroxidase, bromelain, ascorbate oxidase) and/or inhibition testing can be performed to clarify the origin of the IgE binding to latex (protein epitopes versus glyco-peptides). Attention should be paid also in false-positive results with nonglycosylated recombinant allergens in patients with high levels of anti-CCD IgE antibodies.¹³⁵⁷ A serological work-up including at least one CCD screening tool and the recombinant allergens rHev b 1, rHev b 3, rHev b 5 and rHev b 6.01 is highly recommended and might support diagnosis in patients with suspected IgE-mediated NRL type I-allergy^{4,1338,1339} (Figure 140).

The starting point to evaluate sensitization to NRL is the ImmunoCAP specific IgE test with the rHev b 5-amplified latex extract (k82 "spiked" with rHev b 5), which showed superior sensitivity

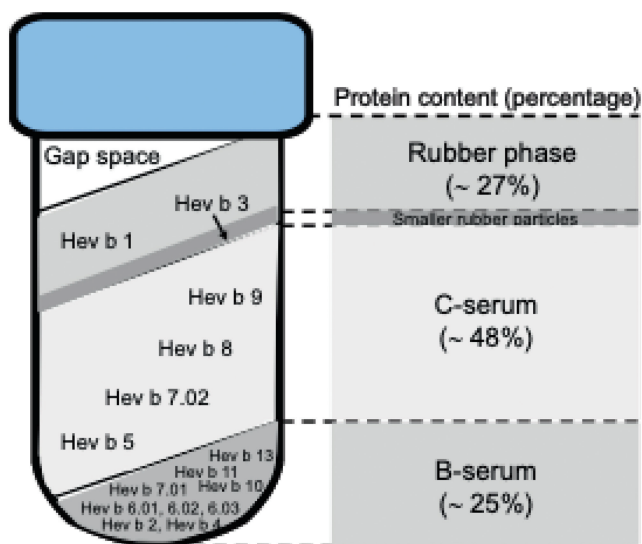


FIGURE 138 Separation of latex sap after centrifugation and distribution of the latex allergens

TABLE 65 Allergens of *Hevea brasiliensis* (para rubber tree latex) according to WHO/IUIS Allergen Nomenclature Sub-Committee

Allergen	<i>Hevea brasiliensis</i> protein (and molecular weight (kDa))	Clinical relevance
Hev b 1*	Rubber elongation factor (14 kDa)	Major allergen in SB
Hev b 2	β -1,3-Glucanase (34 kDa)	Relevance under discussion†
Hev b 3*	Small rubber particle proteins (24 kDa)	Major allergen in SB
Hev b 4	Lecithinase homologue (53-55 kDa)	Minor allergen†
Hev b 5*	Acidic structural protein (16 kDa)	Major allergen in HCW and important in SB
Hev b 6.01*	Prohevein (20 kDa) (precursor of hevein) Hev b 6.02, the major IgE binding domain)	Major allergen in HCW
Hev b 7	Patatin-like protein (esterase) from latex-B- and C-serum (44 kDa) (two isoforms: Hev b 7.01 and Hev b 7.02)	Minor allergen
Hev b 8	Profilin (actin-binding protein) (14 kDa) (several isoforms and variants)	Minor allergen
Hev b 9	Enolase (51 kDa)	Minor allergen
Hev b 10	Manganese superoxide dismutase (MnSOD) (26 kDa)	Minor allergen
Hev b 11	Class I chitinase (30 kDa)	Minor allergen
Hev b 12	Non-specific lipid transfer protein type 1 (nsLTP1) (9 kDa)	Minor allergen
Hev b 13	Esterase (42 kDa)	Relevance under discussion†
Hev b 14	Hevamine (30 kDa)	Minor allergen†
Hev b 15	Serine protease inhibitor (7.5 kDa)	Minor allergen

Hev b: *Hevea brasiliensis*; SB: spina bifida patients, HCW: health care worker; * recommended for specific IgE antibody testing to verify clinical relevance of latex sensitisation according to^{4, 1336, 1337}; †not available in recombinant form; adapted from^{4, 1337}

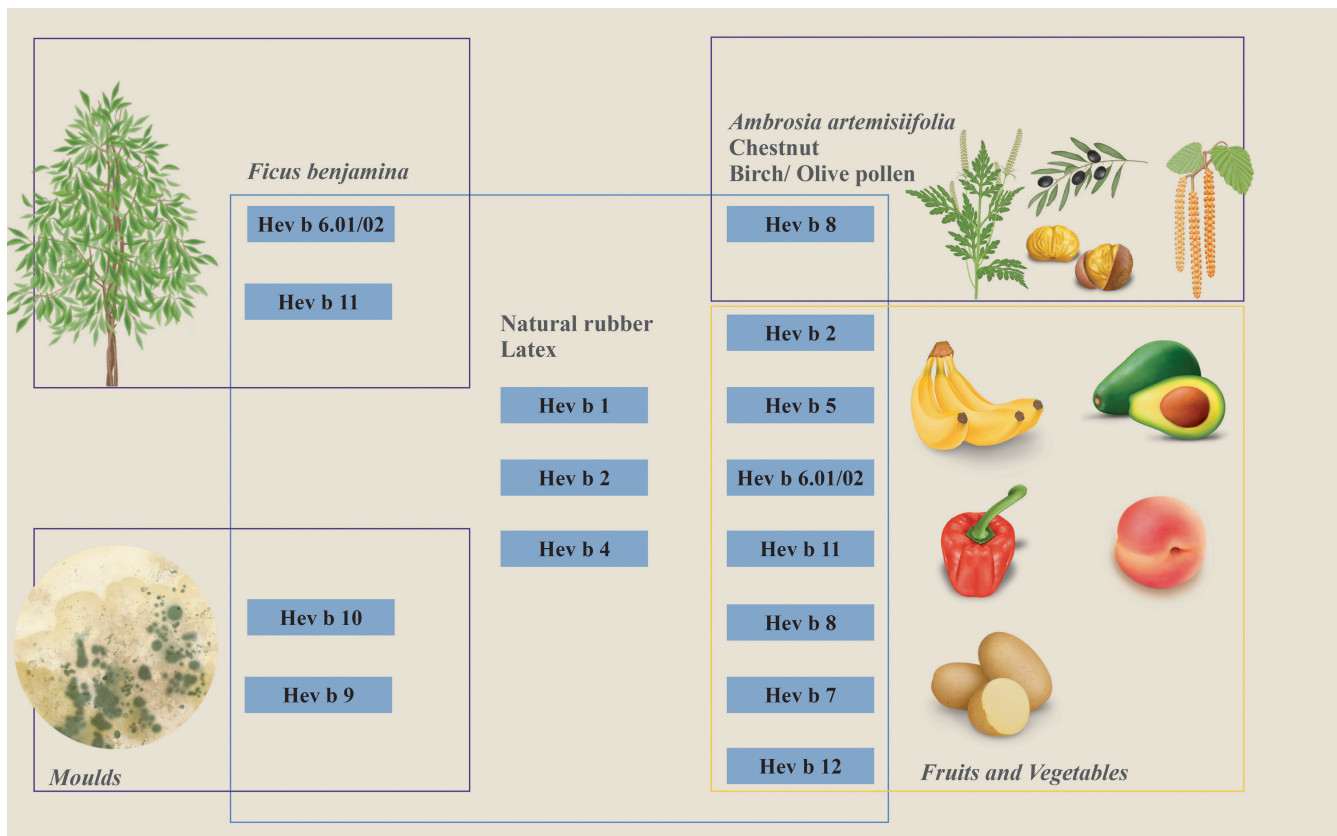
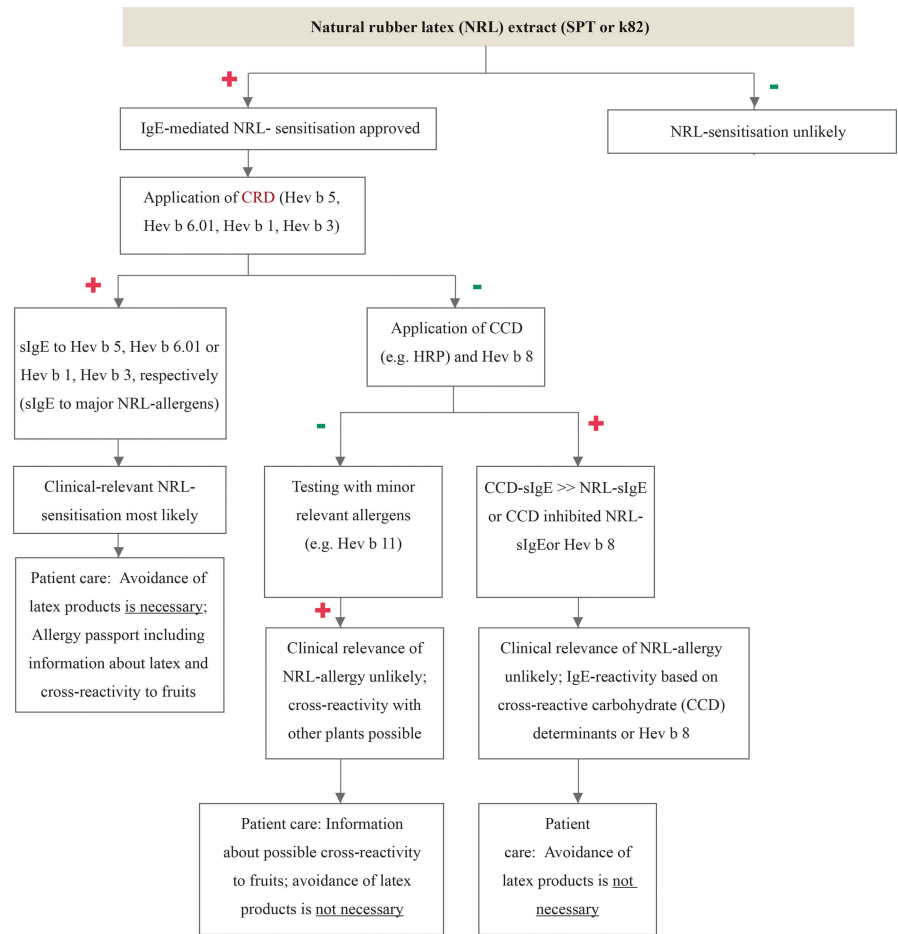


FIGURE 139 Molecular background and association of latex-fruit/vegetable syndrome—allergens with potential importance for cross-reactivity

FIGURE 140 Diagnostic algorithm for natural rubber latex (type I allergy)



compared with the results of previously tested negative sera. This procedure of “spiking” is in general useful if relevant allergens are labile to survive all the steps required for the production of a standardized allergen preparation.¹³⁵⁸ A retrospective study of Vandenplas et al.¹³⁴⁴ demonstrated that high levels of sIgE to rHev b 5 plus rHev b 6.01 or rHev b 6.02 are the most accurate predictors of a positive response in an inhalation challenge test, showing better diagnostic efficiency than the NRL (k82)-ImmunoCAP specific IgE test. On the other hand, none of the subjects in this study with a positive inhalation challenge with NRL gloves and a negative NRL-sIgE result showed reactivity to any of the 12 tested recombinant NRL allergens. Accordingly, the determination of sIgE to available recombinant NRL allergens failed to improve the negative predictive values of the NRL-sIgE test.

Especially for NRL allergy, the *in vitro* diagnostic tools are gaining importance, since in Europe the “classical” diagnostic tools such as latex extracts for skin prick test (different manufacturers withdrawn latex extracts from the market) and powdered gloves for workplace-related bronchial challenge tests are no longer commercially available. This leads to a deficit in the diagnostic procedure and to the need for validated substitutes. In the case of NRL, the recombinant available Hev b-allergens in combination with CCDs tools could be useful in the diagnosis of NRL allergy.

1.2 Wheat allergy in baker's asthma

“Baker's asthma,” which is the generally used term of asthma in bakers and bakery workers, is one of the oldest recognized occupational diseases described by Ramazzini in about 1700. It is one of the most frequently occurring forms of OA. Most studies indicate that wheat (*Triticum aestivum*) flour proteins are allergens for 60-70% of symptomatic bakers,¹³⁵⁹ although other cereals like rye (*Secale cereale*), barley (*Hordeum vulgare*), oats (*Avena sativa*), and corn, and noncereal sources, enzymes, and insects, may be involved because bakeries are complex environments¹³⁶⁰ (Figure 141).

Focusing on wheat, which is in many parts of the world a major crop, and is immensely diverse, with over 25.000 different cultivars.³²² The wheat seeds are composed of endosperm (85%), husk (13%) and a germ (2%). During milling, endosperm was separated from husk and germ and the size of the endosperm was reduced. Wheat flour, which is mainly made from endosperm, is composed of starch (about 70–75%), and four groups of proteins, namely glutenins, gliadins, globulins and water/salt-soluble albumins. In addition, nonstarch polysaccharides (about 2–3%), in particular arabinoxylans, and lipids (2%) are minor but important constituents. Wheat, as a complex allergenic mixture, contains more vegetable proteins than the other two globally important cereals, corn and rice; more than 100 different protein spots can be detected as IgE binding in wheat

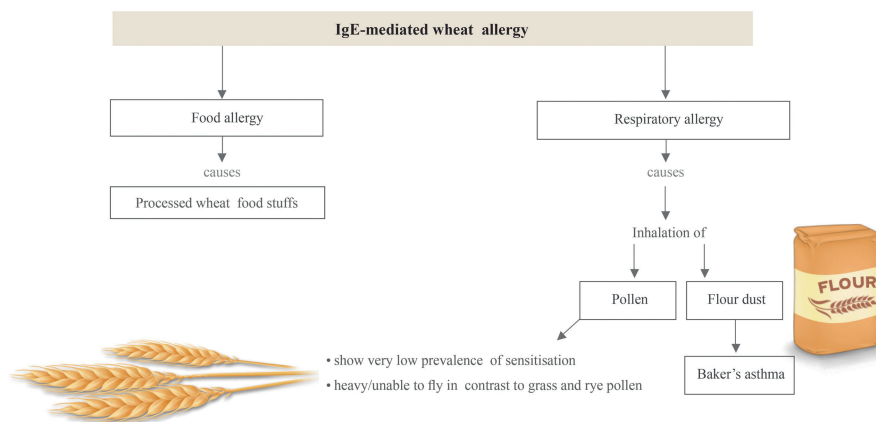


FIGURE 141 Different types of IgE-mediated wheat allergy (food allergy versus respiratory allergy)

flour by means of high resolution 2-dimensional gel electrophoresis and immunoblotting.¹³⁶¹ Twenty-eight wheat allergens are listed so far in the WHO/IUIS Allergen Nomenclature database (www.allergen.org), from the wheat profilin (Tri a 12) up to Tri a 45.¹³³⁶ These allergens are not only characterized with respect to baker's asthma; most are also ingested food allergens. The most relevant allergenic wheat fractions for baker's asthma are the water-/ salt-soluble albumins and globulins (Figure 142, Table 66). Diagnosis is based on a consistent clinical history, skin prick testing and/or specific IgE antibody tests and inhalation wheat challenges. Nonetheless this allergic disease is often misdiagnosed, with significant legal, economic and health consequences for the affected worker. Although specific inhalation challenge with wheat flour is considered as gold standard, it is often difficult to perform. Additionally, wheat and rye skin prick test extracts are not well-characterized and demonstrate a low diagnostic sensitivity.^{1362,1363}

Several wheat allergens isolated as native allergen or produced in recombinant form have been used in IgE assays in different systems (e.g., singleplex, multiplex, ELISA, immunoblotting) and with different groups of bakers; in many cases, the IgE reactivity of these allergens has been determined only in single studies and their clinical relevance is unclear. The highly varying results may reflect differences in populations or in the different approaches to identify IgE-reactive proteins, making comparisons difficult.^{322,1364-1366} One of the best characterized and commercially available single wheat allergen is the omega-5-gliadin (Tri a 19), a 65 kDa seed storage protein, which is involved in wheat-dependent exercise-induced anaphylaxis (WDEIA) and also important for the early childhood type I-wheat allergy. Tri a 19 is not relevant for diagnosis of baker's asthma.¹¹⁹¹ In the study of Sander et al.¹¹⁹¹ a panel of 19 recombinant wheat flour allergens and two cross-reactive carbohydrate determinants (CCD) was investigated using the singleplex technology for specific IgE quantification (CAP-FEIA system) in the sera of 101 bakers with occupational allergy from Germany, Spain and the Netherlands and of 29 pollen-sensitized control subjects without occupational exposure but with wheat-specific IgE. The results indicate that different α -amylase inhibitors are important allergens for baker's asthma, but none of the single allergens reached major allergen status. The geographical origin of the bakers and control subjects was not a significant determinant of the sensitization pattern, and each baker

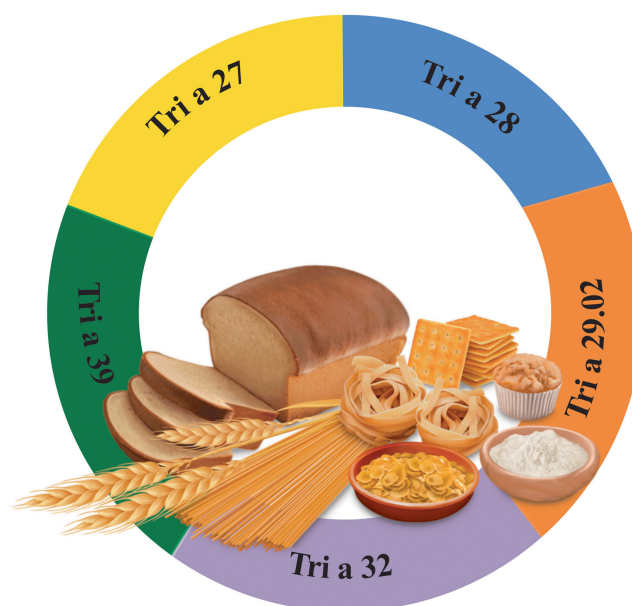


FIGURE 142 Wheat allergens with relevance for wheat-allergic bakers (according to¹¹⁹¹)

showed an individual IgE-binding profile with large interindividual variability. The highest frequencies of IgE binding were found for thiol reductase (Tri a 27) and the wheat dimeric alpha-amylase inhibitor (Tri a 28). Tri a 19, Tri a 26 and Tri a 36, relevant wheat allergens in food-allergic patients, are irrelevant in the diagnostic of baker's asthma. In addition, two isoforms of Tri a 14 (Tri a 14.0101, nsLTP 9.1 and Tri a 14.0201, nsLTP 9.7) were tested and both were classified as minor allergens with 11% and 5% positive IgE response, respectively in all bakers. No cross-reactivity to grass pollen using inhibition experiments was found for Tri a 15, Tri a 30 (both are alpha-amylase inhibitors), Tri a 21 (alpha-beta-gliadin) and Tri a 31 (serpin), whereas nsLTP (Tri a 14) and Tri a 25 (thioredoxin) share epitopes with grass pollen allergens. Although a combination of IgE tests to five components (Tri a 27, Tri a 28, tetrameric alpha-amylase inhibitor CM2 (Tri a 29.02), serine protease inhibitor-like allergen (Tri a 39), and 1-cys-peroxiredoxin (Tri a 32), produced the highest diagnostic efficiency in receiver operating characteristic analyses, but this was still lower than the determination of sIgE antibodies against the whole

TABLE 66 Relevant airborne wheat (*Triticum aestivum*) allergens according to WHO/IUIS Allergen Nomenclature Sub-Committee

Allergen	Biochemical name	Notes
Tri a 15	Wheat monomeric α -amylase inhibitor 0.28 (WMA-1-0.28)	relevant in patients with baker's allergy, but not relevant for those with grass pollen allergy with wheat specific IgE; 9 of 101 (9%) bakers have a positive IgE-response ¹¹⁹¹
Tri a 25	Thioredoxin	not exclusive for baker's asthma; 18 of 101 (18%) bakers and 5 of 29 (17%) patients with grass pollen allergy have a positive IgE-response ¹¹⁹¹
Tri a 27	Thiol reductase homologue	relevant in patients with baker's allergy, but not relevant for those with grass pollen allergy with wheat specific IgE; recognized by 27% of patients with baker's allergy and 0% of grass-pollen allergic patients ¹¹⁹¹
Tri a 28	Dimeric α -amylase inhibitor 0.19	relevant in patients with baker's allergy, but not relevant for those with grass pollen allergy with wheat specific IgE; recognized by 24% of patients with baker's allergy and 0% of grass-pollen allergic patients ¹¹⁹¹
Tri a 29 - Tri a 29.0101 - Tri a 29.0201	Tetrameric α -amylase inhibitor CM1 CM2	in contrast to Tri a 29.0201, Tri a 29.0101 is not exclusively recognized in patients with baker's allergy
Tri a 30	Tetrameric α -amylase inhibitor CM3	relevant in patients with baker's allergy, but not relevant for those with grass pollen allergy with wheat specific IgE; recognized by 10% of patients with baker's allergy and 0% of grass-pollen allergic patients ¹¹⁹¹
Tri a 31	Triosephosphate-isomerase (TPIS)	not exclusively recognized by specific IgE from bakers
Tri a 32	l-cys-peroxiredoxin	relevant in patients with baker's allergy, but not relevant for those with grass pollen allergy with wheat specific IgE
Tri a 33	Serpin	recognized by only 8% of patients with baker's asthma and 0% of grass-pollen allergic patients ¹¹⁹¹
Tri a 34	Glyceraldehyde-3-phosphate-dehydrogenase (GAPDH)	recognized by only 5% of patients with baker's asthma and 0% of grass-pollen allergic patients ¹¹⁹¹
Tri a 35	Dehydrin	recognized by only 2% of patients with baker's allergy and 0% of grass-pollen allergic patients ¹¹⁹¹
Tri a 39	Serine protease inhibitor-like protein (SPILA)	recognized by 18% of patients with baker's allergy and 0% of grass-pollen allergic patients ¹¹⁹¹
Tri a 40	WTAI-CM1 17 protein (α -amylase inhibitor)	recognized by 8% of IgE-positive bakers and 15% of IgE-positive grass-pollen allergic patients; addition of Tri a 40.0101 to the panel of recombinant allergen components had only minimal influence on diagnostic sensitivity and could not improve specificity ¹³⁶⁶

<http://www.allergen.org>, 1CM= Chloroform/methanol-soluble, Bold = the combination of these five allergens in recombinant form coupled to ImmunoCAP produced the best diagnostic performance according to¹¹⁹¹

wheat flour extracts. Additional testing with Tri a 40.0101, a further wheat alpha-amylase inhibitor in the same group of bakers and controls had only minimal influence on diagnostic sensitivity and failed to improve specificity.¹³⁶⁶ Due to the superior diagnostic sensitivity of sIgE antibodies testing against the whole wheat flour extracts, the authors concluded that this is mandatory for the *in vitro* diagnostic procedure of baker's asthma. Nevertheless, the component-resolved diagnostics might help to distinguish between sensitization caused by occupational respiratory flour exposure (baker's asthma), wheat-induced food allergy and wheat seropositivity based on cross-reactivity to grass pollen, but further single wheat allergens should be made commercially available for this purpose.

1.3. Examples of other occupationally relevant plant allergens

Cannabis sativa (hemp) is the most commonly used psychoactive drug worldwide. In recent years, access to cannabis for both medical and nonmedical purposes have expanded. In addition to the use of cannabis as a medicine and intoxicant, there are numerous other uses of the hemp plant, including as edible oils and increasingly as in form of so-called lifestyle products. This is also marked by an increasing number of people working in this growing industry. Increasingly, exposure to cannabis in these workplaces is causing health problems, including allergic complaints in particular.¹³⁶⁷ Due to the increasing legalization, an expansion of the cannabis producing and processing but also the distributing industries is to be expected. In 2020,

around 150,000 people were employed in cultivation, harvesting, processing and distribution. Under these conditions, one can expect an exponential growth of this industry. Workers involved in cannabis production and processing are at risk of inhaling the organic dust. There is a risk of inhaling organic dust from the cannabis plant parts as well as contaminants including bacterial and fungal components. Both the duration and the type of occupational exposure contribute to the different symptoms and courses of disease. Cannabis allergy has been described in cannabis growers, bird breeders, factory workers and laboratory personnel, who have shown both skin and/or respiratory symptoms based on exposure. According to these reports, allergic reaction was caused by cannabis pollen, leaves, hemp seeds and/or flower tops.¹³⁶⁸ It can be assumed that even among heavy cannabis users, personal exposures do not reach the level of occupational exposures, where contact may last for a longer period of time. Studies in recent years have shown a high prevalence of respiratory problems among hemp workers. According to Decuyper et al.¹³⁶⁸ 42% of the participants reported respiratory and/or cutaneous symptoms on occupational cannabis exposure. In addition, many hemp workers were found to have high levels of hemp-specific IgE. So far, four allergens are listed in WHO/IUIS Allergen Nomenclature database (www.allergen.org) (Table 67).

According to the publication of Decuyper et al.¹³⁶⁸ the most effective and practical tests to confirm cannabis allergy are the skin prick tests with an nCan s 3-rich extract and the sIgE rCan s 3. Can s 3-sensitization carries the risk of systemic reactions to plant-derived foods and cofactor-mediated reactions. However, there is still a lack of knowledge on further allergens in cannabis, which could be particularly important for the diagnosis of occupationally induced cannabis sensitization.

Soybean (*Glycine max*) is not only a major food allergen, but inhalation of soy flour is also associated with occupational and environmental allergies.¹³³⁶ Bakers in particular are exposed, as soy flour is often used as an additive in bread. Therefore, it is not surprising that soybeans are associated with baker's asthma.³²² Additionally, sensitization in baker's is also possible for lupine (probably cross-reactivity also to soy) and peanut. The soybean allergens involved in baker's asthma are predominantly high-MW proteins found both in soybean hull and flour.¹³⁷⁰ By contrast, the relatively low-MW proteins concentrated in the soybean hull Gly m 1 (7 kDa, the hydrophobic protein from soybean with two isoforms Gly m 1.0101 and Gly m 1.0102) and Gly m 2 (8 kDa, the defensin) are responsible for the asthma attacks during unloading of soybean at the in the Spanish seaports. Eight soy allergens are listed in WHO/IUIS Allergen Nomenclature database (www.allergen.org). Gly m 4, 5 and 6 are available as CCD-free recombinant soy allergens, but further validation is needed if these allergens are relevant occupational allergens and useful to implement them in diagnosis for occupational asthma in exposed workers.

Green coffee bean dust is known to be a relevant cause of occupational allergic diseases in coffee industry workers, therefore coffee bean proteins may play a role as occupational allergens.¹³³⁶ The first allergen isolated from *Coffea arabica* was a class III-chitinase

with a molecular weight of 32 kDa, listed in the WHO/IUIS database as Cof a 1. Cof a 2 and Cof a 3 (9 and 7 kDa, respectively) two cysteine-rich metallothioneins were identified as further coffee allergens.¹⁶⁹⁴ Peters et al.¹³⁷¹ showed that the only commercially available diagnostic tests based on native extracts of green coffee beans are not sensitive enough to correctly diagnose a substantial number of affected coffee workers. Their results suggest that the natural allergen extracts do not contain sufficient amounts of the Cof a 1, 2 and 3.¹³⁷¹ Therefore, the authors suggested the production and application of recombinant coffee allergens for the development of standardized and sensitive diagnostic tools and/or the spiking the natural extract with recombinant coffee allergens to improve the diagnostics of coffee allergy.

IgE-mediated sensitization to some wood dusts has been described in case reports¹³⁷² and obeche (*Triplochiton scleroxylon*) wood dust is one of the known causes of these immunological OA. An endochitinase 38 kDa was characterized as an allergen and included in the nomenclature list of the International Nomenclature Committee of Allergens (IUIS) and assigned with the official name Trip s 1.¹³⁷³ To date, no further wood dust allergens are listed (<http://www.allergen.org>) and no single wood allergen is commercially available. Specific IgE measurement was possible with an obeche extract (k212) and skin prick testing as described by Hannu et al.¹³⁷⁴ Aranda et al.¹³⁷⁵ described two new proteins as allergen (24 kDa identified as a putative thaumatin-like protein and a 12 kDa gamma-expansin) tested in 12 subjects with confirmed OA/OR, 40 asymptomatic exposed and 10 control subjects. 82% of the cases showed also IgE reactivity to cross-reactive carbohydrate determinants (CCDs). Therefore, testing with CCD tools is strongly recommended for diagnostic specificity, as mentioned previously.¹³⁵⁶

1.4. Occupational relevant allergens of animal origin

Laboratory animal allergy (LAA) is an important occupational disease and is commonly seen in technicians, animal caretakers, physicians, and scientists working in the pharmaceutical industries, university laboratories, and animal breeding facilities^{4,785,1336,1376} (Table 68).

Rodents like mice and rats, which are often used in animal research, are the most common causes of LAA. Urine is the main source of allergenic proteins in both mice and rats, but allergens can also be found in dander, hair, saliva and serum. As with most mammalian inhalant allergens, the major allergens in mice and rats are lipocalins (Mus m 1 and Rat n 1, respectively). In the case of LAA, determination of sIgE antibodies is based on extracts prepared from epithelia, serum-/urine protein as mixture or alone. Only Mus m 1, the major mouse allergen, is available as a single component on the multiplex test system. In addition to skin prick tests and ImmunoCAP Specific IgE test to determine sIgE levels for urine and epithelia allergens, Caballero et al.¹³⁷⁷ studied 20 of 75 workers using multiallergen IgE immunoblotting. This system can be useful in providing the sensitization profile for each allergic worker and therefore it is one step forward in the molecular diagnosis of LAA. An additional important source of occupational animal allergen exposure are stables of cattle farmers. Therefore, allergen from cow dander was responsible for

TABLE 67 Relevant *Cannabis sativa* allergens (Indian hemp) according to WHO/IUIS Allergen Nomenclature Sub-Committee

Allergen	Biochemical name	Notes
Can s 2	Profilin	14 kDa; mostly inhalation, but multiple exposure routes possible, minor allergen (5 of 32 patients were positive in IgE binding tests (www.allergen.org))
Can s 3	Non-specific lipid transfer protein type 1	9 kDa; major allergen responsible for likely-anaphylaxis to cannabis; inhalation; (Up to 72% of 25 Cannabis allergic patients reporting likely-anaphylaxis to Cannabis are Can s 3 sensitised testing by three diagnostic methods (BAT, sIgE, and SPT). (www.allergen.org))
Can s 4	Oxygen evolving Enhancer Protein 2	27.3 kDa; minor allergen
Can s 5	Pathogenesis related protein 10 homologue	17.7 kDa; homologue of the major birch pollen allergen; (35 of 45 subjects with allergy to Cannabis (n=25) and/or birch pollen (n=20) were positive in IgE-binding tested by cytometric bead assay using recombinant protein as the target. (www.allergen.org))

TABLE 68 Mammalian allergens involved in occupational OR/OA¹³³⁵

Allergen	Major allergens	Protein family	Main source	Exposed workers
Cow (<i>Bos domesticus</i>)	Bos d 2	Lipocalin	Dander	Dairy farmers
	nBos d 4*	Alpha-lactalbumin	Milk	Candy and pastry workers
	nBos d 6*	Albumin	Serum	Lab workers
	nBos d 8*	Casein	Milk	Leather tanning
Mouse (<i>Mus musculus</i>)	Mus m 1 **	Lipocalin	Urine	Dermatological powder use
Rat (<i>Rattus norvegicus</i>)	Rat n 1	Lipocalin	Urine	Laboratory animal workers
Guinea pig (<i>Cavia porcellus</i>)	Cav p 1**	Lipocalin	Dander, saliva	Laboratory animal workers
	Cav p 2	Lipocalin	Saliva, dander	Laboratory animal workers

* Commercially available for component resolved IgE-diagnosis (** only on an Allergen Microchip)

most cases of OA in Finland in the last century.^{288,785} The lipocalin is Bos d 2 (20 kDa) is the predominant allergen in cow dander and responsible for respiratory allergy in cattle farmers. Twelve allergens from *Bos domesticus* (*Bos taurus/domestic cattle*) are listed in WHO/IUIS Allergen Nomenclature database (www.allergen.org), but most of them are described as an important allergen group in patients with food allergy induced by milk or meat. Some of them are available as single allergens for CRD (nBos d 6 (bovine serum albumin), nBos d 4 (α -lactalbumin), nBos d 8 (casein)). Only few of them are occupationally relevant. Laboratory workers may be exposed to airborne Bos d 6 (BSA) as it is widely used in biochemical and immunological assays and two cases of OA have been attributed to inhalation of serum albumin powder (Bos d 6) in laboratory workers.^{1378,1379} In addition, in candy and pastry workers Bos d 4^{1379,1380} or in leather tanning the casein Bos d 8¹³⁸¹ appear to play a role.

Occupational exposure to seafood during processing of fish and shellfish may induce OR and OA. The prevalence of occupational rhinitis associated with seafood in epidemiological studies is estimated to be 5-24% and occupational asthma is more commonly associated with shellfish (4-36%) than bony fish (2-8%).^{1054,1382} Several allergenic proteins have been identified in these different groups, 29 fish allergens and 34 allergens from various crustacean and

mollusk species are listed in the WHO/IUIS database (www.allergen.org). The availability of individual seafood allergens for sIgE testing is still limited, but two important allergens parvalbumin (rCyp c 1 from *Cyprinus carpio* and rCad c 1 from *Gadus morhua*) and shrimp tropomyosin (rPen a 1 from *Penaeus aztecus* and nPen m 1 from *Penaeus monodon*) as well as prawn arginine kinase (nPen m 2) and sarcoplasmic calcium-binding protein (nPen m 4) are available as singleplex assays and/ or on multiplex platforms. Further studies are necessary to prove if these recombinant allergens may be relevant for the diagnosis of respiratory allergies in the occupational setting where sensitization results from inhalation exposure. Tropomyosin appears to be important and was recognized as relevant in a case report¹³⁸³ in which a cook's mate was diagnosed with a clinically and occupationally relevant type I allergy to squid with cross-reaction to tropomyosin of other invertebrates and therefore recognized as an occupational disease. Beekeepers, gardeners, farmers, truck drivers, and masons are the professionals most frequently involved in occupational hymenoptera venom allergy.¹³⁸⁴ Relevant allergens are described in Chapters B20 and B21.

1.5 Microbial-derived occupational allergens

Enzymes have been used widely as additives to improve industrial processes. In several workplaces like enzyme production and

refinement, bakeries, food processing, laundry detergent production, animal feeding etc., they act as airborne sensitizers and the prevalence of occupational allergies is increasing.^{1335,1336,1695} Most enzymes are derived from microbes usually produced in bacterial microorganisms belonging to *Bacillus* sp. and *Pseudomonas* sp. and fungal organisms such as *Aspergillus* spp., *Streptomyces* spp. and *Trichoderma* spp. In addition to *Bacillus*-derived proteases, like alkalase and maxatase and savinase, an important diagnostic tool for sIgE testing is alpha-amylase, an allergen relevant to baker's asthma and produced in *Aspergillus oryzae*. This alpha-amylase is listed in the nomenclature list of WHO/ IUIS as Asp o 21. Enzymes derived from *Aspergillus niger* glucoamylase and also cellulase are also relevant in baker's asthma and available for sIgE antibody testing. In bakery workers, a clear relationship between exposure to alpha-amylase, derived from *Aspergillus oryzae*, and IgE production has been reported. The prevalence of sensitization to alpha-amylase and glucoamylase ranged between 5% and 24% among symptomatic workers without sensitization to cereal flour. In the modern baking industry, sensitization to glucoamylase (28%) and cellulase (16%) appears to be most common. Furthermore, xylanolytic enzymes can also cause occupational asthma and occupational rhinitis in bakers. The major determinant of sensitization to enzymes is the level of exposure and its ability to become airborne (summarized in.¹⁰⁵⁴ It is important to realize that enzymes from other species may be cloned into, e.g., *bacillus* and *aspergillus*, which are then used as production organism of the enzymes for industrial purposes. Thus, when dealing with a suspected enzyme allergy, it is important to test the preparation to which the patient has been exposed and not solely rely on extracts or allergens from the production organisms. This may necessitate access to custom-made diagnostics for SPT or IgE measurements.¹³⁸⁵

Diagnosis of mould allergy is complicated because of the heterogeneity of the test materials and the decrease in the number of commercially available mould extracts for SPT.^{1386,1387} Currently only eight single mould allergens from three mould genera are available for molecular diagnosis: rAlt a 1 and rAlt a 6 from *Alternaria alternata*, rAsp f 1, 2, 3, 4, 6 from *Aspergillus fumigatus* and rCla h 8 *Cladosporium herbarum*. Occupational exposure to mould has been reported especially in waste collectors and composting workers. Therefore, e.g., allergic bronchopulmonary aspergillosis (ABPA), an intense inflammatory reaction induced by exposure to *Aspergillus fumigatus* has been reported in garden waste (compost) or garbage collectors.^{1388,1389} For diagnosis to mould see Chapter B07.

2 – Clinical management

Clinical diagnosis

Diagnosis of occupational respiratory allergy is made by a combination of medical history, physical examination, positive methacholine challenge result or bronchodilator responsiveness, determination of IgE-mediated sensitization to HMW allergens (by skin

prick testing and/ or serologically specific IgE measurement, and possibly basophil activation testing to LMW chemicals and HMW allergens). Based on the fact that occupational respiratory allergy especially occupational asthma should be suspected in every adult with new-onset asthma, the question about the occurrence of the respiratory symptoms in relation to the workplace is important. If the patient with asthma-like symptoms is not at work the specific inhalation challenge (SIC) in the laboratory under controlled conditions to the suspected occupational agents is considered the gold standard.¹³⁹⁰ The accuracy of the diagnosis can be improved by the measurement of sputum eosinophils before and after challenge. Additional measurement of the fractional exhaled nitric oxide (FeNO) should be regarded as an additional criterion for the interpretation of SIC with occupational agents, because an increase in FeNO after SIC is highly predictive of occupational asthma. If specific inhalation challenge in the laboratory and/or PEF

monitoring at work are not possible and occupational asthma is strongly suspected from history, a combination of objective evidence of asthma plus a positive skin test or the verification of specific IgE by serological tests to the suspected agent has a high predictive value for occupational asthma¹³⁹¹ (summarized in). Skin prick tests are often taken as the method of choice for the determination of sensitization in practice because results are available immediately and the procedure is cost effective. Unfortunately, only very few skin prick test extracts for the diagnosis of occupational allergy are commercially available. Additionally, there is a lack of standardization and validation for most available extracts of occupational agents and the allergenic potency of SPT extracts may vary significantly among manufacturers.¹³⁶² Therefore, testing of specific IgE with extracts—if available—is in most cases the best choice. Especially in the cases of natural rubber latex allergy recombinant allergens are available and should be used. The binding to CCD should also be checked, especially in the case of plant allergen sources, in order to be able to exclude a probable clinically relevant sensitization.

3 – Clinical cases

Case 1 (published in¹³⁵¹)

Clinical history: A 37 year-old man, developed urticaria with skin redness, itching, dyspnea and tachycardia 5 minutes after drinking a glass of apple juice supplemented with acerola (*Malpighia glabra*; Barbados cherry); no allergy to apple and apple juice was well tolerated; in the past seasonal hay fever symptoms caused by grass pollen and wild herbal pollen; since childhood, a significant contact urticaria induced by natural rubber latex products was well known; OAS after ingesting avocado, celery, walnut, and curry during pollen season.

SPT: wheal size same as for histamine—grass pollen mixture, latex, rye; weak reactions to plantain, hazel, birch pollen; limited reaction to mugwort and ragweed pollen and to curry; intracutaneous skin reaction with acerola pulp and with acerola-containing apple juice; apple juice without acerola negative.

In vitro testing: Total IgE 145 kU/L, specific IgE to latex 24.7 kU/L; acerola (EAST) 1.5 kU/L; CAP class 3 to grass pollen, CAP class 2 to plantain, peanut, tomato soy bean, CAP class 1 to hazelnut pollen, ragweed pollen, banana, green apple, herbal mixture and nut mixture; single recombinant latex allergens: Hev b 6.01 17.1 kU/L, Hev b 6.02 18.7 kU/L, Hev b 8 0.7 kU/L, Hev b 1, 3, 5, 10 <0.35 kU/L. Inhibition studies showed that IgE binding to acerola allergens was completely inhibited by latex and acerola extract, whereas preincubation of the patient's serum with acerola showed nearly complete inhibition to latex (79%) and rHev b 6.01 (85%). rHev b 8 as a solid-phase allergen and acerola as an inhibitor revealed no significant inhibition.

Oral challenge: open oral challenge tests with apple juice with and without acerola and diluted acerola pulp; negative for apple juice; exposure to acerola pulp with a latency period of 5 minutes induced itching and swelling lips

Diagnosis: Latex-acerola cross-reactivity based on Hev b 6.01/Hev b 6.02; Primary sensitization to latex led to cross-reactivity to acerola; (Pro-)hevein is the important allergen and responsible for the cross-reactivity;

Allergologists should include acerola on the growing list of latex-cross-reactive food allergens and inform latex-allergic patients about cross-reacting allergens as the traces of acerola in apple juice.

Case 2 (theoretical) Baker's asthma

Clinical history: A 55-year old baker, ex-smoker, starting his apprenticeship at the age of 14 years, health problems at his workplace started 5 years later: sneezing, running nose, nose blocked, watering eyes, stinging eyes, cough, chest tightness asthma diagnosed 7 years later. The complaints got better at weekends and during holidays. Questions: What are the causes of the workplace-related symptoms? Are the complaints based on sensitization to environmental allergens?

SPT: wheat flour, rye flour and grass pollen positive SPT comparable wheal size than histamine.

Specific IgE: total IgE 110 kU/L, wheat flour 54.2 kU/L, rye flour 15.4 kU/L, grass pollen 5.6 kU/L and alpha-amylase 1.2 kU/L. Workplace-specific challenge test with rye: the patient develops symptoms. Is there a relation between wheat/rye sensitization and grass pollen sensitization? Approach to find the answer: Cross-inhibition testing with wheat and rye, respectively on the solid phase and grass pollen as liquid inhibitor and vice versa. Results: 12% IgE inhibition when rye flour as solid phase and grass pollen as inhibitor; 10% IgE inhibition when wheat flour as solid phase and grass pollen as inhibitor; 87% IgE inhibition when grass pollen as solid phase and rye flour as inhibitor; 90% IgE inhibition when grass pollen as solid phase and wheat flour as inhibitor.

Conclusion: Based on the results of the inhibition experiments, the sensitization to the allergens at the workplace (wheat and rye) are independent of the sensitization to the (possible) cross-reactive allergen (grass pollen). The primary source of the sensitization are wheat flour and rye flour. The patient is also sensitized to the enzyme α -amylase. The clear clinical history, the workplace-related symptoms, the positive SPT and high concentration of flour-specific IgE are good predictors for a positive challenge test. According to the recommendation in¹³⁹² a workplace-related challenge test can be avoided in highly sensitized bakers.

4 – Summary and perspective

For occupational type I-allergy with a huge variety of different sensitizers, only limited numbers of allergens are characterized on the molecular level so far and assessment of sIgE reactivity to single allergen components has only been studied in detail for NRL and wheat allergy in the case of baker's asthma. Only few of allergen components are available for the routine diagnostics. Natural rubber latex is an excellent model for the useful application of recombinant single allergens for improvement of routine diagnostics (via spiking of the latex extracts with rHev b 5) and the use of individual allergens is possible to determine the risk of severe allergic reactions, therefore recommendations to avoid latex products and cross-reactive foods can be given to the patient. The characterization of the allergic components responsible for wheat allergy in bakers has been the focus of several research groups for many years. Since the individual sensitization profile of bakers to wheat proteins is very heterogeneous, no main allergen could be identified. However, the group of alpha-amylase inhibitors seem to be important allergens for wheat allergy in bakers, but these allergens are not commercially available. Therefore, using the wheat extract is the best *in vitro* diagnostic option. Wheat ω 5-gliadin (Tri a 19), the major sensitizing allergen WDEIA, and other typical wheat allergens in food allergic individuals (e.g., Tri a 26 or Tri a 36) are irrelevant for the diagnosis of baker's asthma. Further characterization of occupational sensitizers for IgE-mediated diseases (occupational rhinitis/ asthma, dermatitis) is urgently needed, with candidate or promising markers to be evaluated in multi-center studies to improve *in vitro* diagnostics for occupational allergic diseases. This is important as many skin prick test extracts are at risk of being withdrawn from the market (especially rare allergen preparations such as occupational allergens), which could lead to a lack of diagnostic tools. Therefore, increased efforts should be made to apply the knowledge of allergen characterization to the field of occupational allergy diagnostics.

C01 – Profilins

Riccardo Asero, Domingo Barber, Giorgio Celi

Highlights

- Up to 50% of pollen allergic patients are sensitized to profilin.
- Sensitization virtually always follows primary sensitization to a specific pollen source.
- On SPT most pollen sources score positive.
- Clinical relevance is variable but potentially present.
- Up to 50% of sensitized patients may have food allergy, oral allergy syndrome in most cases.
- Clinical reactivity to raw tomato, melon, watermelon, and/or citrus fruits is typically associated with profilin hypersensitivity
- Patients tolerate processed foods.
- The spectrum of offending plant foods is sometimes very large.

1 – The protein

Profilin is a protein of 12-15 kDa in size present in all eukaryotic cells and involved in the organization of cytoskeleton as well as in signal transduction. Although it can form oligomeric assemblies (mostly as a consequence of protein purification and storage processes) profilin is a monomeric actin-binding protein and a key regulator of actin-filament dynamics during processes such as cell movement, cytokinesis, and signalling¹³⁹³ (Figure 143, Table 69). In higher plants, it is identified as an allergen in monocot and dicot angiosperms.

2 – The protein family

As mentioned above, profilins are present in all eukaryotic cells, and in effect there is an officially registered profilin (Tyr p 36) originating from the storage mite, *Tyrophagus putrescentiae*. Nonetheless, as plant profilins represent the only clinically relevant allergens of this family described so far, the present chapter will deal specifically with plant derived profilins. Profilins from higher plants constitute a family of highly conserved proteins showing sequence identities of at least 75% even between members from distantly related organisms (Tables 70 and 71). In view of the high sequence homology, cross-reactivity between profilins is extremely common and involves virtually every plant source. (Figure 144). Thus, profilin can be considered the archetypal pan-allergen.¹³⁸⁹

3 – Clinical relevance of profilin

A) As an airborne allergen (Table 70)

Profilins are able to elicit IgE responses in 10-60% of pollen-allergic patients^{1394,1395}; however, the sensitization prevalence seems on the rise, as more and more allergic patients seen at allergy departments show sensitization to a large number of botanically

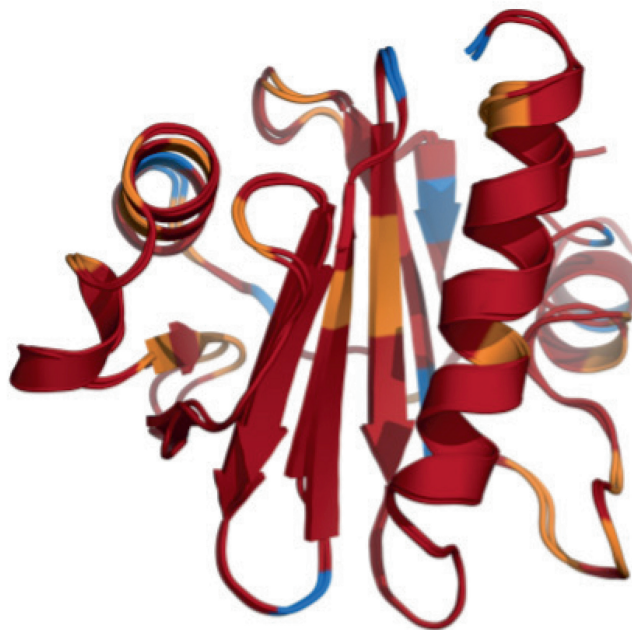


FIGURE 143 Three dimensional structures of Phl p 12 (grass pollen) and Cuc m 2 (melon). Identical amino acid residues are in red, conservative changes in orange and unrelated amino acids are in blue. The structure is highly conserved in all profilins, consisting of a central 6-stranded antiparallel β -sheet and two α -helices situated at the N- and C-terminal sides. The figure was generated using PyMOL Molecular Graphics System v1.6.

TABLE 69 Basic protein characteristics of Phl p 12

Allergen source	Grass pollen
Protein family	Profilin
Biological function	Actin binding protein
Molecular structure	Central 6-stranded β sheet and two α -helices
Theoretical MW	14 kDa
Length	131 amino acids
Ligand binding	Actin, poly-L proline
Glycosylation	None
Distribution	Every plant cell

unrelated plants¹³⁹⁵. As a rule, profilin sensitization follows sensitization to a primary, major allergenic pollen source. In most cases, grass pollen is responsible for profilin hypersensitivity but, depending on geographical differences, also birch pollen, ragweed pollen, and mugwort pollen may act as primary sensitizers.^{610,1395} Being a minor pollen allergen, profilin sensitization is almost always associated with the sensitization to major pollen allergens. Assessing the clinical relevance of profilin as an airborne allergen is quite complicated, and in effect, it has been seldom investigated. In a Spanish study, only profilin-sensitized, pollen-allergic patients scored positive on a conjunctival provocation test with date palm profilin, thus suggesting that profilin may act as an aeroallergen.¹³⁹⁶ Another study based on nasal/bronchial provocation with date palm profilin in sensitized subjects confirmed this finding.¹³⁹⁷ However, in a field

TABLE 70 Selection of profilins from different pollen sources

Botanical family	Allergen source	Allergen
Fagales	Birch (<i>Betula pendula</i>)	Bet v 2
	Hazel tree (<i>Corylus avellana</i>)	Cor a 2
	Alder (<i>Alnus glutinosa</i>)	*Aln g 2
	Hornbeam (<i>Carpinus betulus</i>)	*Car b 2
	Oak (<i>Quercus alba</i>)	*Que a 2
	Beech (<i>Fagus sylvatica</i>)	*Fag s 2
Graminae	Timothy (<i>Phleum pratense</i>)	Phl p 12
	All other grass pollen species	“Allergen” 12
Asteraceae	Mugwort (<i>Artemisia vulgaris</i>)	Art v 4
	Ragweed (<i>Ambrosia artemisiifolia</i>)	Amb a 8
Urticaceae	Pellitory (<i>Parietaria judaica</i>)	Par j 3
Oleaceae	Olive (<i>Olea europaea</i>)	Ole e 2
	Ash (<i>Fraxinus excelsior</i>)	*Fra e 2
Cupressaceae	Cypress (<i>Cupressus sempervirens</i>)	*Cup s 8
Euphorbiaceae	Annual mercury (<i>Mercurialis annua</i>)	Mer a 1
	Date palm (<i>Phoenix dactylifera</i>)	Pho d 2

*additional allergens listed in allergome

TABLE 71 Profilins from some plant foods

Botanical family	Allergen source	Allergen
Rosaceae	Apple (<i>Malus domestica</i>)	Mal d 4
	Peach (<i>Prunus persica</i>)	Pru p 4
	Pear (<i>Pyrus communis</i>)	Pyr p 4
Cucurbitaceae	Melon (<i>Cucumis melo</i>)	Cuc m 2
Actinidiaceae	Kiwi (<i>Actinidia deliciosa</i>)	Act d 9
Apiaceae	Celery (<i>Apium graveolens</i>)	Api g 4
	Carrot (<i>Daucus carota</i>)	Dau c 4
Rutaceae	Orange (<i>Citrus sinensis</i>)	Cit s 2
Leguminosae	Peanut (<i>Arachis hypogaea</i>)	Ara h 5
	Soybean (<i>Glycine maxima</i>)	Gly m 3
Solanaceae	Tomato (<i>Solanum lycopersicum</i>)	Sola l 1
Bromeliaceae	Pineapple (<i>Ananas comosus</i>)	Ana c 1
Corylaceae	Hazelnut (<i>Corylus avellana</i>)	Cor a 2
Brassicaceae	Yellow mustard (<i>Sinapis alba</i>)	Sin a 4
Asteraceae	Sunflower (<i>Helianthus annuus</i>)	Hel a 2
Moraceae	Fig (<i>Ficus carica</i>)	*Fic c 4

*additional allergens listed in allergome

study, the clinical impact of profilin hypersensitivity turned out to be rather limited, as most sensitized patients reported symptoms only in the specific season of the primary sensitizing pollen source.⁵⁷⁹ Nonetheless, the only one case of primary sensitization to profilin reported so far suffered from long lasting seasonal symptoms.¹³⁹⁸ Further, recent studies showed that in certain geographic areas profilin sensitization represents a marker of more severe respiratory allergy in patients with pollen-mediated rhino-conjunctivitis and asthma, probably because in most cases it occurs in patients with multiple primary sensitizations to different sources.¹³⁹⁹

Clinical relevance of profilin as an airborne allergen

- Up to 50% of pollen allergic patients are sensitized to profilin.
- Sensitization virtually always follows primary sensitization to a specific pollen source.
- On SPT most pollen sources score positive.
- Clinical relevance is variable but potentially present.

B) As a plant food allergen (Table 71)

Although profilin is present in every plant-derived food, its relevance as a food allergen has long been underestimated.^{52,1400} Nonetheless, its role as a plant food allergen in about 50% of sensitized subjects has recently emerged¹¹³⁵, with clinical allergy to certain foods such as melon, watermelon, citrus fruits, banana, pineapple, persimmon, zucchini, and tomato being characteristically associated with profilin hypersensitivity (see Chapter B15).^{694,1135,1401-1407} In view of the high pepsin sensitivity of this

protein¹⁴⁰², the clinical expression of profilin-induced food allergy is in most cases the oral allergy syndrome. However, cases of systemic allergic reactions induced by profilin have been reported in specific areas in Spain where the levels of grass pollen allergy are extremely high (Figure 145). Oral provocation of food allergic patients with low doses of purified profilin has proven to induce severe reactions in grass pollen (GP) allergic patients resident in areas with high grass pollen exposure.¹⁴⁰⁸ This fact should be taken into account when evaluating severe food allergic reactions in areas where GP allergy is dominant. Further, recent studies showed that under certain conditions (i.e., in the presence of certain specific co-factors) labile plant food allergens, including profilin, are able to induce systemic allergic reactions in patients not reactive to stable allergens.³³⁸ Finally, one study showed that plant food-induced allergic reactions in profilin-hypersensitive individuals are associated with significant damage to the epithelial barrier of the oral mucosa. Such damage favours profilin penetration into the oral mucosa with subsequent local inflammation³³⁹. Another physical feature that may contribute to the “reduced allergenicity” of profilins is their low thermal stability.¹⁴⁰⁹

Clinical relevance of profilin as a plant food allergen

- Up to 50% of sensitized patients may have food allergy
- Oral allergy syndrome in most cases
- Raw tomato, melon, watermelon, and citrus fruits are typically associated with profilin sensitization
- Patients tolerate processed foods
- Spectrum of offending plant foods is sometimes very large

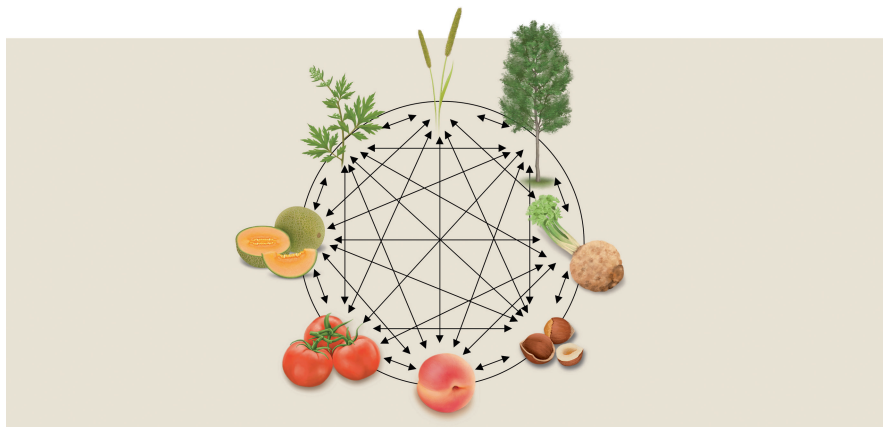


FIGURE 144 Cross-reactivity between profilins from different pollen sources and plant foods

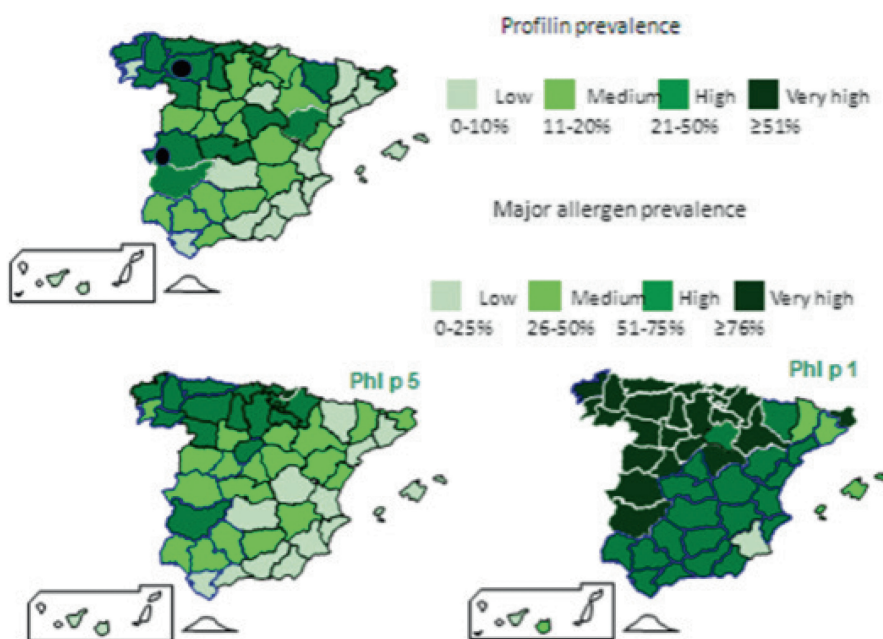


FIGURE 145 Areas of Spain characterized by a high prevalence of profilin sensitization (dots) where some cases of severe profilin-induced food allergy have been recorded.

C) Profilin and natural rubber latex allergy

The end of the last century and the beginning of the current one have been characterized by an impressive increase in the prevalence of allergy to natural rubber latex. NRL contains many allergenic proteins, including profilin (Hev b 8). Therefore, the crude extract of *Hevea brasiliensis* latex scores often positive in patients with multiple pollen sensitization. This has frequently caused concern for the risk of intra-operative anaphylactic reactions. However, most latex products have been replaced by synthetic products and therefore the risk of allergic reactions due to latex allergens including profilin is no longer a health issue. Furthermore, patients who show uniquely IgE reactivity to profilin in NRL can undergo surgery and other medical procedures without any risk.^{1410,1411}

4 - Clinical management

Profilin hypersensitivity can be diagnosed *in-vivo* by SPT using a commercial profilin-enriched date palm pollen extract that has been

available only in Italy, Spain, and Austria²⁸⁰; such extract for skin testing shows a sensitivity and specificity that is very close to that of the recombinant grass pollen profilin for *in-vitro* use (Phl p 12).¹⁴¹² Unfortunately, due to problems in registration at national regulatory agencies this product is currently no longer being commercialized in certain countries. Several recombinant profilins are currently available for the routine *in-vitro* diagnosis of IgE hypersensitivity. In the ImmunoCAP Specific IgE test (Thermo Fisher Scientific) Phl p 12, Bet v 2, Pru p 4, and Hev b 8, the profilins from grass pollen, birch pollen, peach, and natural rubber latex are the 4 profilins currently available. In the ImmunoCAP ISAC multiplex assay, Mer a 1 (from annual mercury) is present as well (in a former version of the assay Ole e 2, the olive pollen profilin, has also been present but is currently withdrawn due to its low sensitivity¹⁴¹³). A second multi-allergen panel commercially available, namely the ALEX 2, shows sensitivities to the profilins Phl p 12, Bet v 2, Hev b 8, Pho d 2 (date palm), Mer a 1 (annual mercury), and Cuc m 2 (melon). Regarding the clinical significance of profilin-specific IgE levels, their value in predicting an oral allergy syndrome seems extremely limited or absent.¹⁴¹⁴ Since profilins are extremely well conserved and cross-reacting and show an

equivalent IgE-binding potency^{1415,1416} one wonders if a representative marker allergen is sufficient to detect hypersensitive patients. In this sense, one study showed that one single marker protein is sufficient to diagnose or exclude sensitization.¹⁴¹³ As for the homology between profilins from different sources, extracts from two pollen sources, namely *Parietaria* and cypress, score frequently negative in profilin hypersensitive patients.⁶⁹⁴ Whether this depends on a more limited cross-reactivity of profilins from these two plants with the other profilins.^{1417,1623} or on a lower concentration of the protein in the extract¹⁴¹⁸ is still a matter of debate; further studies are needed to clarify this point. Profilin hypersensitivity⁶¹⁰ does not normally require special clinical measures. Although most pollen sources are probably able to induce profilin hypersensitivity, from a respiratory point of view the clinical impact of the inhaled protein is in most cases quite limited.⁵⁷⁹ Interestingly enough, profilin co-sensitization is associated with less severe reactions to foods in patients hypersensitive to lipid transfer proteins or seed storage proteins as well as, in certain geographic areas, with less severe respiratory allergy in patients sensitized to airborne allergens.¹⁴¹⁹ Some studies have demonstrated the disappearance of profilin-associated food allergy in subjects submitted to injection immunotherapy with different pollen extracts.^{613,1420} Regarding allergen immunotherapy, one study showed that commercial extracts for allergen immunotherapy of most pollens (except *Parietaria*) are rich in profilin and hence potentially able to desensitize to this allergen,¹⁴²¹ although grass pollen extracts have the highest relative content.¹³⁹⁷ Profilin strong reactors constitute a good model to understand the link between respiratory and food allergy and to understand the causes underlying severe allergic phenotypes. Multiomic analysis of grass pollen allergic, profilin sensitized patients, suffering from severe profilin-mediated food reactions, allowed to conclude that uncontrolled T cell proliferation induced by exposure to profilin might explain these severe phenotypes.¹⁴²² In fact, differential profilin induced T cell proliferation in profilin sensitized subjects has been described comparing patients from Denmark and Spain.¹⁴²³ This model, together with other sharing similar severe allergic phenotypes, could offer new clues to understand allergic disease evolution.¹⁴²⁴ In conclusion, the data coming from the most recent studies support the need of a change in the way we have been looking at this allergen.⁶⁹³

5 – Clinical cases

Case 1

Clinical History: A 32-year-old woman resident in Extremadura, a heavily grass-exposed area, with pollen allergy and clinical history of oral allergy syndrome, urticaria, and asthma following the ingestion of melon, watermelon, banana, peach and orange. Open challenge with melon was positive.

Tests with extracts: On SPT, with exception of cypress, all pollens scored positive, and no reactivity to peach LTP was detected.

Tests with molecules: ImmunoCAP ISAC (ISU-E) microarray scored positive for: Cyn d 1: 76.7, Phl p 1: 75, Phl p 2: 21, Phl p 4: 1.0, Phl p 5: 51.5, Phl p 6: 2.6, Phl p 11: 0.73, Bet

v 2: 6.39, Hev b 8: 5.14, Mer a 1: 8.94, Phl p 12: 1.64, Mux F3: 0.67, Ole e 1: 0.37.

Oral challenges: On DBPCFC, the administration of 74 µg of pure date palm pollen profilin induced OAS and FEV1 decline of 20%, that were treated with antihistamine and bronchodilators.

Diagnosis: Grass pollen allergy with severe profilin-mediated food allergy was eventually diagnosed.

Case 2

Clinical history: A 38-year-old man living in the surroundings of Milan, Italy. At the age of 32 starts having severe rhino-conjunctivitis from mid-August to the end of September when he returns home from the summer holidays at the sea (where he is well). After 3 years, oral itching following the ingestion of melon, watermelon, tomato, banana, orange, and peach appears.

Tests with extracts: SPT with pollen allergens score positive for grass, mugwort, ragweed, plantain, birch, hazel, plane, and olive, and negative for *Parietaria* and cypress. A SPT with profilin-enriched date palm pollen extracts scores intensely positive.

Tests with molecules: The ImmunoCAP Specific IgE test scores strongly positive for Amb a 1 and Phl p 12, and negative for Phl p 1, Phl p 5, Phl p 7, Art v 1, Pla a 1, Pla l 1, Bet v 1, Cor a 1, Ole e 1, Par j 2, and Pru p 3.

Diagnosis: Respiratory allergy to ragweed and profilin-induced food allergy is eventually diagnosed.

C02 – PR-10-like allergens

Heimo Breiteneder, Lorenz Aglas, Jörg Kleine-Tebbe, Christine Hafner

Highlights

- The major birch pollen allergen Bet v 1 represents the archetype of all PR-10-like allergens and is the primary sensitizer in birch pollen endemic regions.
- The presence of homologous allergens in Fagales tree pollen explains the IgE cross-reactivity between pollen from hazel, alder, beech, oak, hornbeam and chestnut.
- Minute amounts of PR-10-like allergens in raw fruits, nuts, vegetables and legumes can induce patient-individual patterns of oropharyngeal symptoms and sometimes severe allergic reactions in Bet v 1-sensitized individuals.
- Testing for Bet v 1-specific IgE is sufficient. The relevance of cross-reacting pollen or foods can be clinically clarified by seasonal and food-related symptoms without the need for further testing of Bet v 1 homologues.

1 – The PR-10 protein architecture

Bet v 1, the major allergen of birch pollen, was the first plant allergen and the first allergenic PR-10-like protein to be cloned and characterized (Table 72). The cDNA sequence coding for Bet v 1.0101 was discovered on July 3, 1988, and published in 1989, representing the most abundant isoform in birch pollen (50–70%).¹⁴²⁵

The protein architecture of Bet v 1 comprises a highly curved seven-stranded anti-parallel beta-sheet that embraces a 25 residue-long C-terminal alpha-helix.¹⁴²⁶ The beta-sheet and the C-terminal part of the long alpha-helix are separated by two consecutive alpha helices that connect the beta1- and beta2-strands. All these structural elements contribute to the formation of a large hydrophobic cavity. Structural information is available for various Bet v 1-homologous allergens from plant foods (Figure 146) and their overall similarity clearly illustrates the molecular basis for the cross-reactivity of these proteins. Although Bet v 1 contains a variety of different T cell epitopes, a major T cell epitope located at the C-terminal amino acid residue positions 142–156 was recognized by T cells from 61% of birch pollen allergic individuals studied.¹⁴²⁷ This part of the molecule shares high sequence similarities with various Bet v 1-related tree pollen allergens. The extent of T cell cross-reactivity with Bet v 1-related food allergens also corresponded to the degree of sequence similarity of the food allergens' C-termini to the Bet v 1 amino acid residues 142–156.¹⁴²⁷ The sensitizing capacity of different Bet v 1 homologues from plant foods seems to correlate with the presence of immunodominant T cell epitopes.¹⁴²⁸ The Bet v 1-specific IgE response is polyclonal, and epitopes are spread across the entire Bet v 1 surface. Furthermore, the IgE recognition profile of Bet v 1 is variable and highly patient specific.¹⁴²⁹

TABLE 72 Protein characteristics

Protein characteristics	
Allergen source	<i>Betula pendula</i> (syn. <i>B. verrucosa</i> , <i>B. alba</i>), birch
Protein family	Bet v 1
Protein subfamily	PR-10
UniProt accession number	P15494
Crystal structure available	Yes
Molecular structure	Seven-stranded anti-parallel β -sheet flanked by three α -helices
Theoretical molecular weight	17439.63 Da
Molecular weight measured by MS	17439.6 +/- 0.3 Da
Length	159 amino acid residues
Ligand binding	Yes
Oligomerization state	Monomeric
Glycosylation	No
Disulfide bonds	0
Isoelectric point	5.39
Synthesis	In the cytoplasm of the vegetative cells of birch pollen
Distribution	Pollen is distributed into the environment by wind dispersal and can enter the indoor environment.

2 – The PR-10-like family of allergenic proteins

2.1. The Bet v 1-like superfamily

In 1980, pathogenesis-related proteins (PR proteins) were defined as "proteins encoded by the host plant but induced only in pathological or related situations" and subsequently grouped into families.¹⁴³⁰ Today, the list of PR proteins comprises 17 families.¹⁴³¹ When the sequence of Bet v 1 was discovered in 1989, the PR-10 family had not been defined yet, but it was noted that Bet v 1 was homologous to a PR protein from pea.¹⁴²⁵ Bet v 1 is constitutively expressed in pollen at rather high concentrations. Hence, the term PR-10 for the Bet v 1 homologous allergens is not entirely correct. These constitutively expressed proteins are referred to as PR-10-like proteins (Table 73). Since the discovery of Bet v 1, the number of sequences related to the Bet v 1 sequence has grown steadily and rapidly. The version 34.0 of the Pfam database attributes 114,208 sequences from 7,426 species to the Bet v 1-like superfamily (<http://pfam.xfam.org/ clan/CL0209>, accessed 12/2021) compared to 14,065 sequences from 1,452 species listed in the Pfam version 29.0 mentioned in the first edition of this book published in 2016. The member proteins of this superfamily are found in all three domains of life, i.e., archaea, bacteria and eukaryotes, and all share the Bet v 1 architecture.³⁴⁰ The Bet v 1-like superfamily of proteins comprises 25 families, one of which is the Bet v 1 family (<http://pfam.xfam.org/ family/PF00407>). The Bet v 1 family in turn is composed of 11 subfamilies.³⁴⁰ One of these subfamilies is the PR-10 group of

PR-10 allergens of Fagales pollen



Homologous PR-10 allergens found in plant foods

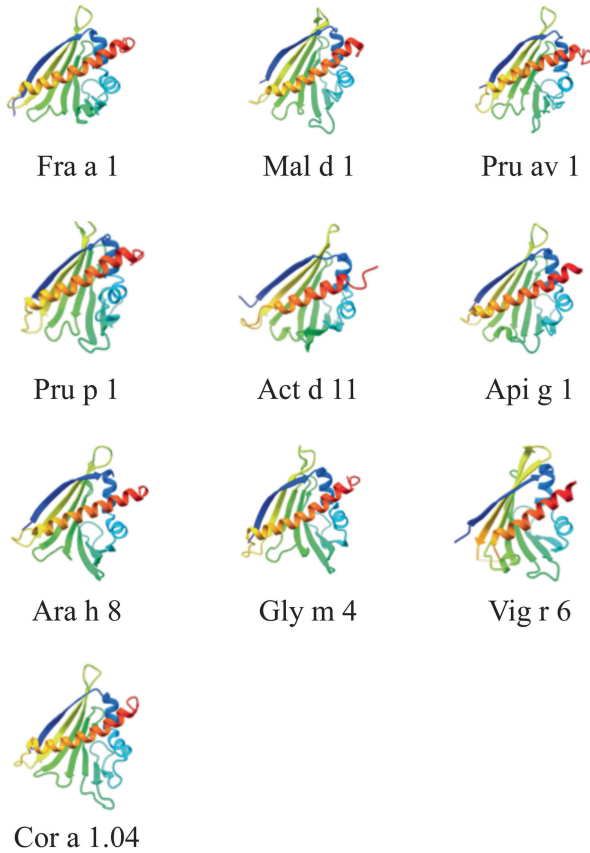


FIGURE 146 Ribbon representations of birch pollen Bet v 1 (PDB 4A88) and homologues from beech pollen (Fag s 1; PDB 6ALK), strawberry (Fra a 1; PDB 6ST8), apple (Mal d 1; PDB 5MMU), cherry (Pru av 1; PDB 1E09), peach (Pru p 1; PDB 6Z98), green kiwifruit (Act d 11; PDB 4IGV), celery (Api g 1; PDB 2BK0), peanut (Ara h 8; PDB 4M9B), soybean (Gly m 4; PDB 2K7H), mung bean (Vig r 6; PDB 2FLH) and hazelnut (Cor a 1.04; PDB 6GQ9) rainbow-colored from blue at the N-terminus to red at the C-terminus. The 3D images were created with the molecular modeling system UCSF ChimeraX (<https://www.rbvi.ucsf.edu/chimerax/>).

proteins to which almost all of the Bet v 1 homologous allergens belong. There are only two examples of allergens that are members of other subfamilies, the kiwi allergen Act d 11³⁴² from the RRP/MLP (= ripening related proteins/major latex proteins) subfamily, and the mung bean allergen Vig r 6³⁴³ from the CSBP (= cytokinin-specific binding proteins) subfamily.

TABLE 73 Characteristics of the PR-10-like family of allergenic proteins

Common tertiary structure with a seven-stranded antiparallel β -sheet with a long C-terminal α -helix and two short α -helices
Sequences with high identities
Small cross-reactive molecules of around 17 kDa present in pollen of early flowering Fagales trees as well as in fruits, vegetables, nuts and seeds
Binding of various ligands in a hydrophobic cavity

TABLE 74 Bet v 1-homologous pollen allergens of Fagales pollen

Botanical family	Botanical subfamily	Allergen source	Allergen
Betulaceae	Betuloideae	Birch (<i>Betula pendula</i>)	Bet v 1
		Alder (<i>Alnus glutinosa</i>)	Aln g 1
	Coryloideae	Hazel (<i>Corylus avellana</i>)	Cor a 1
		Hornbeam (<i>Carpinus betulus</i>)	Car b 1
		Hop-hornbeam (<i>Ostrya carpinifolia</i>)	Ost c 1
Fagaceae	Fagoideae	Beech (<i>Fagus sylvatica</i>)	Fag s 1
	Quercoideae	Oak (<i>Quercus alba</i>)	Que a 1
		Sawtooth oak (<i>Quercus acutissima</i>)	Que ac 1
		Holly oak (<i>Quercus ilex</i>)	Que i 1
		Mongolian oak (<i>Quercus mongolica</i>)	Que m 1
	Castaneoideae	Chestnut (<i>Castanea sativa</i>)	Cas s 1

2.2. Bet v 1-homologous allergens in Fagales tree pollen and plant foods

Birch pollen is one of the most common causes of IgE-mediated allergy in Northern and Central Europe as well as in North America. The major sensitizing allergen present in birch pollen is Bet v 1 to which 93% of individuals with birch pollen allergy produce specific IgE.¹⁴³² Birch belongs to the botanical order Fagales, which comprises seven families. Allergies have been strongly associated with pollen produced by the early flowering trees of the families Betulaceae and the Fagaceae (Table 74 and Figure 147). In general, allergic reactions to Fagales pollen are initiated by independent sensitization to pollen of members of the Betuloideae or Coryloideae subfamilies. However, 25% of the IgE epitopes of the Betuloideae and the Coryloideae pollen allergens are unique for the respective subfamily, whereas pollen allergens from the Fagaceae are generally cross-reactive.¹⁴³³

Homologues of Bet v 1 have also been identified in a wide range of plant foods.¹⁴³⁴ The most frequently observed clinical entity is caused by IgE antibodies that cross-react between Bet v 1 and its homologues in fruits, nuts, seeds and vegetables. They induce predominantly oropharyngeal symptoms, which are summarized by the term oral allergy syndrome (OAS).³² Severe reactions to Gly m 4, the Bet v 1 homologue from soybean (see chapter B17), have been observed in a subpopulation of Bet v 1-allergic individuals.¹²¹⁷ Bet v 1-allergic patients are at risk to acquire various plant food allergies, and even to react to novel foods without prior exposure.³² In contrast to Bet v 1, Bet v 1-related food allergens are regarded as incapable of sensitizing

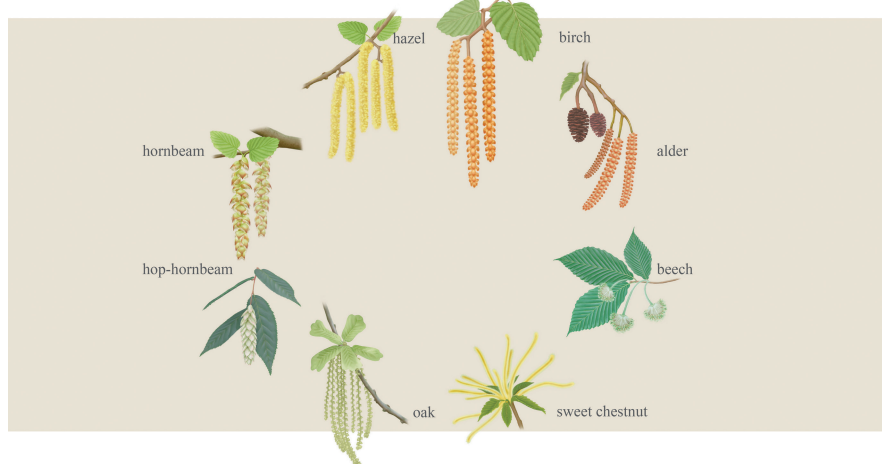


FIGURE 147 Tree pollen sources of Bet v 1 homologous PR-10-like allergens. Official allergen names assigned by the WHO/IUIS Allergen Nomenclature Subcommittee (allergen.org) are shown in [Table 74](#). Extensive IgE cross-reactivity between the various pollen PR-10-like allergens has been determined.

predisposed individuals. The few exceptions that were described include Dau c 1 from carrot,¹⁴³⁵⁻¹⁴³⁷ and Cor a 1 from hazelnut.¹⁴³⁸

The list of plant food allergens to which Bet v 1-allergic individuals may react is quite varied and most likely connected to the variation in individual IgE epitope patterns described.¹⁴²⁹ Interestingly, most of the Bet v 1 cross-reactive allergens are found in fruits of the *Rosaceae*, in vegetables of the *Apiaceae*, and in seeds of the *Fabaceae* family ([Table 75](#) and [Figure 148](#)).

Amino acid sequence identities between PR-10-like pollen allergens are between 49 and 96% ([Table 76](#)) and identities between Bet v 1 and plant food allergens fall between 17 and 68% ([Table 77](#)). There is also a range of plant foods that contain cross-reactive Bet v 1 homologues that have not yet received an official allergen nomenclature designation including almond, asparagus, parsley, ginseng, plum, nectarine, fig, mango, persimmon, jackfruit, and chickpea.

2.3. Ligand binding of PR-10-like proteins

The large hydrophobic cavity at the core of most PR-10-like allergens enables the binding of several physiological and experimental ligands, mainly low molecular weight compounds of the chemical classes of cytokinins, flavonoids and sterols.^{340,1439} Ligand binding was described for Fagales pollen allergens from birch, hazel, and beech but also for Bet v 1-homologous allergens from peanut, strawberry, cherry and peach. Although ligand binding in PR-10-like allergens appears to occur in a promiscuous, nonspecific way, the ligand preference varies greatly among the different proteins and among isoforms, as indicated by differences in binding affinities.^{476,1440,1441} The role of ligand binding of PR-10-like allergens ranges from an involvement in flavonoid biosynthesis (polyphenolic plant metabolites involved in color/flavor production and UV protection) to more generalized mechanisms in plant development, defense and reproduction.¹⁴⁴²⁻¹⁴⁴⁴ A detailed description of ligand classes interacting with PR-10 allergens is provided in ([Table 78](#)).

In most PR-10-like allergens, ligand-binding results in a stabilization of the protein via structure rigidification, which, in case of Bet v 1, leads to increased thermal stability and a decreased proteolytic susceptibility without changing its secondary structure. However, clinical practice shows us that the majority of Bet v-1-homologue-containing foods will only lead to symptoms when consumed raw

TABLE 75 Bet v 1- homologous allergens of plants

Botanical family	Allergen source	Allergen
<i>Rosaceae</i>	Strawberry (<i>Fragaria x ananassa</i>)	Fra a 1
	Apple (<i>Malus domestica</i>)	Mal d 1
	Apricot (<i>Prunus armeniaca</i>)	Pru ar 1
	Cherry (<i>Prunus avium</i>)	Pru av 1
	Peach (<i>Prunus persica</i>)	Pru p 1
	Pear (<i>Pyrus communis</i>)	Pyr c 1
	Raspberry (<i>Rubus idaeus</i>)	Rub i 1
<i>Actinidiaceae</i>	Golden kiwifruit (<i>Actinidia chinensis</i>)	Act c 8
	Green kiwifruit (<i>Actinidia deliciosa</i>)	Act d 8
<i>Apiaceae</i>	Celery (<i>Apium graveolens</i>)	Act d 11
	Carrot (<i>Daucus carota</i>)	Api g 1 Dau c 1
<i>Fabaceae</i>	Peanut (<i>Arachis hypogaea</i>)	Ara h 8
	Soybean (<i>Glycine max</i>)	Gly m 4
	Mung bean (<i>Vigna radiata</i>)	Vig r 1 Vig r 6
<i>Corylaceae</i>	Hazelnut (<i>Corylus avellana</i>)	Cor a 1.04
<i>Solanaceae</i>	Tomato (<i>Solanum lycopersicum</i>)	Sola l 4
<i>Juglandaceae</i>	English walnut (<i>Juglans regia</i>)	Jug r 5
<i>Cannabaceae</i>	Indian hemp (<i>Cannabis sativa</i>)	Can s 5

(see also chapter 3.3). Two naturally occurring, physiological ligands were described for Bet v 1, the glycosylated flavonoid quercetin-3-O-sophoroside and phytoprostanes, which are pollen-associated lipid mediators.^{471,1445} The stabilization of proteolytic cleavage sites by ligand binding affects the presentation of Bet v 1 peptides to T cells via the major histocompatibility complex class II molecules. The phytoprostane PPE1 hereby fulfills a dual role, on the one hand, by stabilising Bet v 1 against proteolytic degradation and, on the other hand, by modulating the activity of proteolytic enzymes. The increased proteolytic resistance mediated by these ligands and the altered presentation of T cell peptides suggests a contribution of ligands to allergic sensitization.

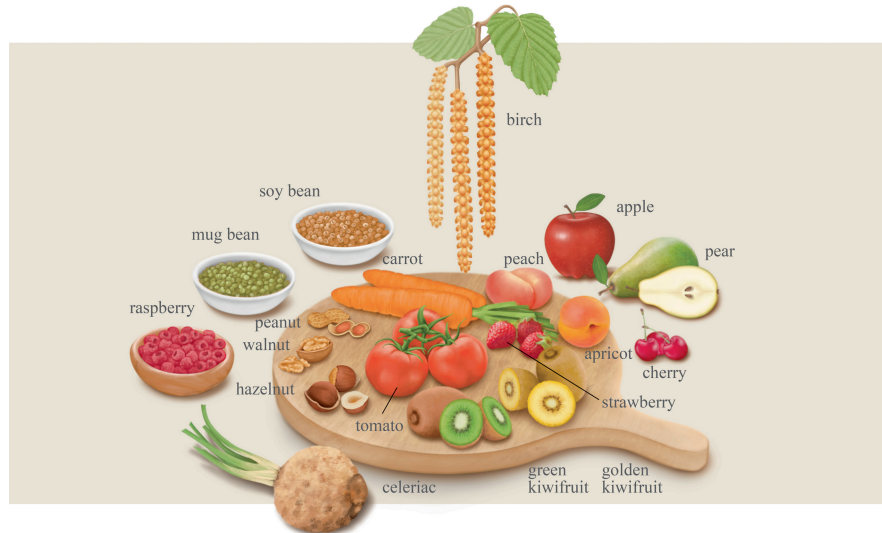


FIGURE 148 Plant food sources of PR-10-like allergens. Official allergen names are shown in Table 75. These PR-10-like allergens for which IgE cross-reactivity with the major birch pollen allergen Bet v 1 has been determined are found in the botanical families *Rosaceae* (apple, pear, cherry, apricot, peach, strawberry, raspberry), *Actinidiaceae* (golden kiwifruit, green kiwifruit), *Apiaceae* (celeriac, carrot), *Fabaceae* (peanut, soybean, mung bean), *Solanaceae* (tomato), *Corylaceae* (hazelnut), and *Juglandaceae* (walnut). Inhibition experiments have also indicated the presence of allergenic members of the PR-10 family in plum, nectarine, fig, mango, persimmon, jackfruit, chickpea, potato, chicory, fennel, poppy seeds, chamomile, parsley, anise seeds, cumin seeds, and coriander seeds (not shown).

TABLE 76 Amino acid sequence identities (%) between PR-10 allergens of Fagales pollen

	Aln g 1	Bet v 1	Car b 1	Cas s 1	Cor a 1	Fag s 1	Ost c 1	Que a 1	Que ac 1	Que i 1	Que m 1
Aln g 1											
Bet v 1	81										
Car b 1	74	73									
Cas s 1	59	59	53								
Cor a 1	76	72	88	58							
Fag s 1	64	66	58	67	62						
Ost c 1	76	74	96	54	91	60					
Que a 1	60	58	52	89	55	67	53				
Que ac 1	59	58	49	85	53	63	50	83			
Que i 1	61	59	51	90	55	67	53	89	84		
Que m 1	62	58	56	76	59	67	57	75	73	74	

Percent identity matrix was created using Clustal2.1 (EMBL-EBI)



3 – Clinical relevance

3.1. General importance

Bet v 1 is regarded as a marker allergen for a primary sensitization to pollen of birch and other Fagales trees (e.g., alder, hazel, hornbeam, beech, oak), and an indicator of cross-reactivity to a number of related major pollen and plant food allergens. Clinically, Bet v 1 and its homologues in pollen represent important inhalant allergens, and are considered important inducers of birch pollen-associated plant food allergies.

3.2. Epidemiology

According to the European Respiratory Health Survey published in 2007, the prevalence of sensitization to birch pollen was on average 6.4% with a maximum of 22.4% in Northern Europe.⁶²⁶ Sensitization was generally high in Northern and Central Europe and low in the South of Europe. A large nationwide study in Germany on a representative sample of children and adolescents published in 2013 revealed the presence of IgE specific for birch pollen allergens in 15% of the individuals in the age group of 3 to 17 years.⁷⁹⁸ In the age group of 13 to 17 years, 15.7% of the girls and 21.7% of

TABLE 77 Amino acid sequence identities (%) between Bet v 1 and homologous PR-10 allergens found in plants

	Act c 8	Act d 8	Act d 11	Api g 1	Ara h 8	Bet v 1	Can s 5	Cor a 1.04	Dau c 1	Fra a 1	Gly m 4	Jug r 5	Mal d 1	Pru ar 1	Pru av 1	Pru p 1	Pyr c 1	Rub i 1	Sola l 4	Vig r 1	Vig r 6	
Act c 8																						
Act d 8	70																					
Act d 11	21	21																				
Api g 1	45	48	13																			
Ara h 8	45	39	18	38																		
Bet v 1	50	50	17	42	47																	
Can s 5	50	52	20	42	44	54																
Cor a 1.04	53	54	19	39	54	68	58															
Dau c 1	45	47	16	81	36	38	38	37														
Fra a 1	53	54	16	44	51	54	64	61	41													
Gly m 4	47	45	18	39	71	47	50	58	37	52												
Jug r 5	57	55	19	42	54	67	61	68	40	69	54											
Mal d 1	53	50	18	39	50	56	61	62	37	77	53	74										
Pru ar 1	64	61	18	46	50	60	59	64	44	73	51	73	72									
Pru av 1	56	54	18	42	51	59	64	66	39	81	53	74	85	76								
Pru p 1	57	55	18	42	50	59	65	64	40	83	53	74	83	77	98							
Pyr c 1	52	50	20	39	50	57	60	62	38	76	52	75	94	73	84	84						
Rub i 1	52	57	15	43	47	55	59	62	40	69	48	71	68	72	72	72	68					
Sola l 4	48	48	19	39	41	44	49	50	35	49	43	51	44	51	49	50	43	47				
Vig r 1	43	44	17	39	67	44	46	54	35	46	76	52	47	48	47	47	45	46	41			
Vig r 6	23	23	15	20	20	26	25	19	18	24	24	25	23	25	22	23	22	22	24	23		

Percent identity matrix was created using Clustal2.1 (EMBL-EBI)

15



95

TABLE 78 Reported ligand classes interacting with PR-10 allergens

Ligand chemical class	Reported allergens
Animal steroid hormones	Ara h 8, Cor a 1, Que a 1
Brassinosteroid (analog)	Bet v 1, Cor a 1, Fag s 1, Pru av 1, Que a 1
Cytokinin	Cor a 1, Bet v 1, Fag s 1, Pru p 1
Extrinsic and non-physiological ligands	Bet v 1, Fag s 1
Fatty acids	Bet v 1, Cor a 1, Que a 1
Flavonoids	Ara h 8, Bet v 1, Cor a 1, Fag s 1, Fra a 1, Que a 1
Organic compounds	Ara h 8, Cor a 1, Fag s 1
Phytosteranes	Bet v 1

the boys had IgE specific for birch pollen allergens. IgE sensitization to birch pollen allergens in adults (age 19 to 79 years) was found to be 17.4% and sensitization to Bet v 1 15.2%.¹²²⁶ Approximately half of all sensitized individuals will develop symptoms such as allergic rhinoconjunctivitis or allergic asthma.⁷⁹⁸

According to the National Health and Nutrition Examination Survey (NHANES) 2005-2006 sensitization to birch pollen in the United States was on average 10% with slightly higher sensitization rates of 12.3% and 11.8% in the Northeast and Western regions, respectively.⁶²⁷ The NHANES 2005-2006 data also demonstrated racial/ethnic differences. Sensitization to birch pollen was significantly

higher in non-Hispanic blacks (14%) compared with non-Hispanic whites (9.1%).⁶²⁷

Oak, hazel and alder pollen account for sensitization to Bet v 1-homologous proteins in East Asia, with oak tree pollen dominating over pollen of other tree species due to climate change¹⁴⁴⁶. The IgE-sensitization rate to oak pollen has more than doubled from 4.7% in 1998 to 9.8% in 2019 in children living in the Seoul metropolitan area.¹⁴⁴⁶

3.3. Symptoms (respiratory allergy)

Typical mucosal symptoms of tree pollen allergy occur during springtime in the respective regions (in Central Europe between February and May) with maxima depending on the current climate and the region's altitude:

- itchiness, redness, tearing of the eyes
- itch in the nose, oropharyngeal itch, (repeated) sneezing, runny and/or stuffy nose
- occasionally dry cough (particularly during or shortly after exercise), dyspnea, pressure sensation on the chest, wheezing, bronchial secretion and difficulty in breathing as indicators for increasingly affected lower airways (asthmatic lower airway inflammation)
- occasionally flu-like symptoms such as fatigue, body aches and headaches

Clinical diagnoses of intermittent (seasonal) rhinoconjunctivitis and allergic asthma due to birch pollen become more likely when mucosal symptoms occur during the same season in subsequent

years. Additional oropharyngeal symptoms that occur in approximately 2/3 of birch pollen allergic individuals after consumption of certain raw plant foods indirectly confirm a suspected birch pollen allergy. In a minority of birch pollen allergic individuals, ingestion of processed plant foods such as roasted hazelnuts, products containing roasted hazelnuts, or cooked celeriac can induce OAS.

3.4. Symptoms (oral exposure)

Minute amounts of Bet v 1-homologous proteins can induce various, transient, predominantly oropharyngeal symptoms (Table 79) with a quick onset (sometimes immediately and often within minutes) after consumption of raw plant foods (Table 75, Figure 148) in approximately 2/3 of birch pollen allergic individuals. These symptoms are often referred to as “oral allergy syndrome” (OAS), implicating a particular clinical entity. This is not the case, since

- oropharyngeal symptoms can occur quite variably including different degrees of severity (Table 79 symptom complex A)
- diffusion of inflammatory mediators (i.e., histamine) and/or neurogenic reflexes can prompt additional severe symptoms in the head area (Table 79 symptom complex B) or
- systemic, sometimes anaphylactic symptoms can occur in rare cases (Table 79 symptom complex C)

Noteworthy, oropharyngeal symptoms are not unique or specific for Bet v 1-induced cross-reactions or certain food items, since other food allergens are able to induce similar symptoms:

- profilin-containing plant foods (see chapter C01)
- nonspecific lipid transfer protein (nsLTP)-containing plant foods (see chapter C03)
- gibberellin-regulated protein (GRP)-containing plant foods (see chapter C09)

- seed storage proteins-containing plant foods (see chapter C08)
- cystein protease-containing plant foods
- β-1,3-glucanase-containing plant foods
- animal derived food allergens (see chapters B10-B14)

Thus, the so-called OAS does not represent a defined clinical entity (syndrome) but a rather variable symptom complex. The occurrence of only oropharyngeal symptoms reflects the physicochemical properties of the particular food allergens, which in the case of the Bet v 1-homologous proteins are

- instability, i.e., poor resistance to degradation by digestive proteolytic enzymes and consequently rarely a substantial intestinal absorption
- excellent aqueous solubility (quick onset of symptoms after mucosal exposure).

From a clinical point of view, a large and over the years increasing number of reported Bet v 1-related cross-reactive plant foods indicates a high level of Bet v 1-specific IgE based on a broad polyclonal IgE repertoire.

The following variables are presumably involved in rare, severe clinical reactions to foods containing Bet v 1-homologues:

- a strong Bet v 1-specific IgE response (high specific IgE/total IgE ratio)
- a broad Bet v 1-specific IgE repertoire (indirectly reflected in a large panel of implicated plant foods)
- the ingested amount of a particular Bet v 1-homologue containing food
- ingestion of a Bet v 1-homologue-containing food on an empty stomach

TABLE 79 Potential symptoms due to Bet v 1-associated IgE cross-reactivity to plant foods

Symptom complex	Symptoms	Organ/localization
A. Limited oropharyngeal symptoms (frequent)	itch (“tingling”, “tickling”, “prickle”)	lip mucosa, oral mucosa, palate
	burning, stinging	palate, throat
	mild mucosal swelling	lip mucosa, oral mucosa, palate, throat
	itch, redness, tearing	conjunctiva
B. Additional symptoms in the head area (isolated or with symptoms from A) (rare events)	itch, sneezing, runny nose, stuffy nose	nose
	itch	ears (internally, Eustachian tubes)
	cutaneous and subcutaneous swelling (urticaria, angioedema)	eye lids, lips, cheeks, ears, face
	severe (internal) mucosal swelling, globus sensation, difficulty swallowing,	palate, throat, larynx
	hoarseness (indicating vocal cord or larynx edema), shortness of breath, stridor	
C. Systemic symptoms (extremely rare)	itch, redness, hives, swelling (urticaria, angioedema)	localized, multifocal or generalized at the skin
	nausea, vomiting, abdominal pain, diarrhea	stomach, intestine
	breathing difficulties, chest pressure, chest tightness, shortness of breath, wheezing, cough, sputum (optional)	bronchi
	dizziness, general weakness, unconsciousness, circulatory collapse	heart circulation

- differences in stability of the Bet v 1-homologue in the respective food items (more often systemic reactions due to hazelnuts, soy, carrots and celeriac in comparison to e.g., apples)
- matrix effects of certain food items (e.g., soy) with high protein content, protecting the immediate degradation of a Bet v 1-homologue-containing food.

An increase in oropharyngeal symptoms during or shortly after the birch pollen season is generally observed. Natural birch pollen exposure might boost the Bet v 1-specific IgE response resulting in a broadened IgE repertoire.

Occasionally, patients experience oropharyngeal symptoms (Table 79) after consumption of typical Bet v 1-related plant foods without suffering from inhalant symptoms during the tree pollen season. This observation, a (so far) clinically “silent” Bet v 1 sensitization, can still prompt unexpected allergic reactions after the first consumption of Bet v 1-related plant foods. Without knowledge of the molecular relationship both, the diagnosis of a birch pollen (Bet v 1)-associated plant food allergy, and proper consultation of the affected individuals might be unnecessarily delayed.

The most frequently observed allergy to soy in Central Europe is based on the serological cross-reactivity of Bet v 1-specific IgE (70%) with its homologue Gly m 4 from soybean (see chapter B17). In general, reactions occur following the ingestion of large amounts of soy-based products that did not undergo major processing steps (e.g., soymilk, soy-based protein powders). Reactions can be systemic and severe and have been observed in about 10% of birch-pollen allergic individuals.¹²¹⁷

Conclusions on clinical relevance

- Sensitization to the PR-10-like allergen Bet v 1 and its homologous proteins in pollen from Fagales tree species occurs worldwide except in South Africa and the tropics.
- Around half of all sensitized individuals will develop symptoms.
- Around 70% of birch pollen allergic individuals suffer from associated plant food allergy.
- Impact of IgE-cross-reactivity on clinical symptoms of food allergy is still unknown.
- Molecule-based therapeutic approaches are under investigation.

4 – Clinical management

Diagnostic testing of Bet v 1-related allergies

IgE sensitization to Bet v 1 can be assessed (Figure 149) directly by allergen-specific IgE testing to Bet v 1, or indirectly by SPT with birch pollen extract or allergen-specific IgE testing with birch

pollen extract when sensitization to Bet v 2 has been excluded by allergen-specific IgE testing. Convincing analytical specificity after birch pollen extract testing is only obtained in case of a limited sensitization profile (i.e., if only positive to pollen of Fagales trees). If a positive SPT result was already obtained with a birch pollen extract, allergen-specific IgE should rather be tested to Bet v 1, providing more (analytical) specificity than another birch pollen extract for *in vitro* diagnosis.

Commercial plant food extracts (for SPT and IgE testing) often show false-negative results and should be avoided due to a low abundance and a lack of stability of Bet v 1 homologous food allergens. Instead, prick-to-prick tests can be performed with suspected fresh, raw plant foods. Despite a lack of standardization, this approach can provide a qualitative, indirect demonstration of IgE sensitization.

No value of broad molecular testing of Bet v 1-sensitized patients

Is it worth it to demonstrate additional IgE sensitizations/cross-reactions to Bet v 1-homologues such as allergen-specific IgE to Mal d 1, Cor a 1.04, Pru p 1 and many others? It is not, since numerous positive serological cross-reactions are to be expected when Bet v 1-specific IgE is present.¹⁴⁴⁷ Thus, such test results are not informative in terms of their clinical relevance without further clinical information. Only a clear-cut negative IgE result obtained for an individual Bet v 1-homologous allergen (i.e., Dau c 1, Gly m 4, Pru p 1), obtained with a sensitive IgE test (cut-off at 0.1 kU/L; singleplex assay) could reliably rule out an IgE sensitization/cross-reactivity and a subsequent clinically relevant food allergy due to Bet v 1-cross-reactivity. Unfortunately, this scenario does hardly exist. Instead, rational and targeted testing (i.e., allergen-specific IgE only to Bet v 1) is strongly recommended. Sensitization tests in case of Bet v 1-associated cross-reactions are only meaningful, if the results will potentially lead to clinical consequences.

Interpretation of Bet v 1-related IgE sensitizations

Interpretation of a test addressing the clinical relevance of a previously demonstrated Bet v 1-sensitization can only be obtained by taking into account the patient's clinical history. Thus, a detailed anamnesis is very important in case a birch pollen-associated food allergy is in question. The following suggested diagnostic work-up can facilitate a final interpretation of the clinical relevance of a sensitization test (i.e., positive birch pollen SPT, positive Bet v 1-specific IgE):

- The subject should be systematically asked, whether oropharyngeal (or other) allergic symptoms (Table 79) occurred and after consumption of which raw plant foods these symptoms appeared.
- The list of foods should not only address the most common ones as apples and hazelnuts, but the whole panel of potentially Bet v 1-cross-reactive plant foods (Table 75, Figure 148). Oral challenge tests can help—in case of missing clinical information or vague anamnesis

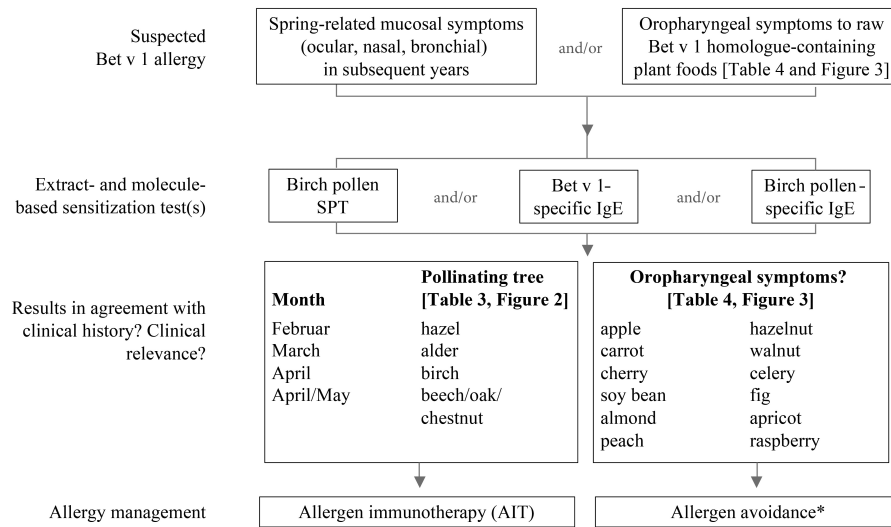


FIGURE 149 Diagnostic algorithm in case of Fagales tree pollen and/or Bet v 1 homologue-related food allergy to raw plant foods. *If the patient tolerates the processed food, only the unprocessed food should be avoided.

- to prove or rule out clinical cross-reactions. They can also serve as a prospective test of a potentially cross-reactive, but so far never eaten plant food.

Oral food challenges, however, are rarely routinely performed in case of Bet v 1-associated food allergies for the following reasons:

- There is no urgent indication in case of solely oropharyngeal symptoms.
- They are not easy to interpret due to predominantly subjective symptoms.
- There are almost no validated dose-dependent tests.
- There are only a few proven published protocols for oral challenge procedures with Bet v 1-associated plant foods.¹⁴⁴⁸
- They are tedious to perform considering the number of potentially cross-reactive foods.

It is of utmost importance to advise patients that only those Bet v 1-related foods should be avoided in their raw form, when they have induced typical allergic symptoms. Avoiding every potentially cross-reactive food that may contain a Bet v 1-homologous allergen is clinically not justified and would be exaggerated. The same is true for plant foods, showing indirectly after prick-to-prick tests or directly after serological analysis positive IgE sensitizations. Even the entire panel of Bet v 1-homologues employed for diagnostic purposes would not be able to separate silent from clinically relevant sensitizations in case of positive test results.

Diagnostic recommendations for Bet v 1-related allergy

- Bet v 1-homologues in tree pollen extracts for diagnostic purposes will induce positive SPT and IgE reactions to pollen of several Fagales tree (Table 74, Figure 147) not necessarily being clinically relevant.

- Prick-to-Prick tests with fresh (raw) foods are superior diagnostic tools compared with commercial food extracts in case of birch pollen-associated plant food allergies due to low stability of Bet v 1-homologues.
- After being spiked with recombinant Bet v 1-homologues (e.g., Cor a 1) birch pollen-associated plant food extracts (i.e., hazelnut extract) can bind more IgE, increase assay sensitivity (lowered “limit of quantitation,” LoQ) and provide elevated allergen-specific IgE values.
- At the same time “spiking” will unfold more positive (potentially clinically irrelevant) sensitizations, pointing to general drawbacks of extract-based diagnostics (i.e., high sensitization rates to peanut in Central Europe due to cross-reactive natural Bet v 1-homologue Ara h 8 in peanut extracts).
- Bet v 1-specific IgE serves as a reliable marker for potential, serological cross-reactions to a number of plant foods (Table 75, Figure 148). The clinical relevance of potential cross-reactions is systematically addressed by the physician together with the patient based on the subject's individual symptoms after consumption of raw foods containing Bet v 1-homologues.
- Positive specific IgE to Bet v 1-homologues plant food allergens (i.e., Pru p 1 from peach) demonstrates allergic sensitization, being only clinically relevant in case of corresponding symptoms.
- A negative IgE results (i.e., to Gly m 4 from soy, approx. in only 25% of Bet v 1-sensitized subjects) would exclude serological cross-reactivity with certainty and clinically relevant symptomatic cross-reactions as well.

The rule-of-thumb for the diagnostic work-up of Bet v 1-associated allergic reactions is: “The physician's interpretation, based on the patient's individual symptoms, and not the outcome of a sensitization test will establish the decision about the clinical relevance of previous diagnostic findings (personal comment by author JKT).

Sensitization can be tested by skin prick testing or *in vitro* by extract- or molecule-based assays. IgE test results must be interpreted always in the context of the anamnesis. At present, all Bet v 1-related allergens that are of broader clinical relevance are available as recombinant proteins but only a few for diagnostic purposes.

Extract composition for allergen-specific immunotherapy

Due to the high cross-reactivity of the major allergens Bet v 1, Cor a 1, Que a 1 and Aln g 1 of birch, hazel, oak and alder pollen, respectively, birch pollen mono-extracts are suitable for specific immunotherapy of a tree pollen allergy.⁶¹⁶ Whether immunotherapy with tree pollen extracts has a beneficial influence on associated plant food allergies is still under discussion. Most studies were performed on birch pollen-associated apple allergy. As the apple allergen Mal d 1 has a very high sequence identity to Bet v 1, one might expect very good results from a birch pollen-based immunotherapy. However, the results from several studies on birch pollen-associated apple allergy are controversial.^{1172,1173,1636} Likewise, no clinical effect on a birch pollen-associated hazelnut allergy was observed after one year of specific immunotherapy with a birch pollen extract.¹⁶³⁷

Therefore, an oral allergy-syndrome to birch pollen-associated plant foods in the absence of pollen induced respiratory symptoms should not be considered as a main criterion for selecting patients for birch pollen immunotherapy. Whether immunotherapy with Bet v 1-homologous plant food allergens might be an option for patients with severe oral allergy symptoms has to be studied in larger clinical trials. Data from phase II studies have shown that sublingual immunotherapy with recombinant Mal d 1 can effectively reduce oral allergy symptoms in apple-allergic patients,⁶⁵ and oral immunotherapy with raw apple significantly increased increased Mal d 1-specific IgG4 and tolerance to apples¹⁴⁴⁴

5 – Clinical cases

Case 1 (original, #6166):

History: Female, 39 yrs: Since 2015 for the first time during spring time eye itch, tearing, swelling, sneezing, runny and blocked nose, later chest tightness, wheezing, coughing and white sputum. In addition, since spring 2015 after raw fruits (apples, cherries, peaches) itchy throat.

In-vivo testing: SPT (wheal diameter [mm]): hazel 12, alder 5, birch 4, oak 6.

In-vitro testing: Total IgE 190 kU/L, specific IgE to Bet v 1: 91 kU/L (>47% of total IgE indicating a strong sensitization).

Diagnosis: (A) Allergic rhinoconjunctivitis due to Fagales tree pollen; (B) Bet v 1-associated food allergy (oropharyngeal symptoms to certain raw *Rosaceae* fruits). Recommendations: Allergen-specific immunotherapy with birch pollen extract with caution during the escalation phase (high relative specific IgE to Bet v 1 is associated with potential adverse events). Avoidance of raw Bet v 1-cross-reactive pome and stone fruits (see history); cooked, baked or roasted plant products without dietary restriction (due to thermal instability of Bet v 1-related allergens).

Comments: (a) Strong Bet v 1-sensitization based on high absolute IgE values and high ratio between Bet v 1-specific IgE and total IgE; (b) despite the short allergy history (first allergy season!) strong indication for AIT due to the rapid disease development including lower airways and cross-reactive oropharyngeal symptoms.

Case 2 (original, #6112)

History: Male, 35 yrs: Since 10 years Fagales tree pollen-induced rhinoconjunctivitis with itchy eyes, sneezing, runny nose, sore throat, itch in the ears, general fatigue. After ingestion of raw apples, hazelnuts, cherries, peaches, apricots, strawberries, blueberries*, grapes* within 5 minutes itchy and sore throat, itchy eyes and ears for 15 minutes, after soy products loose stool.

In vivo testing: SPT (wheal diameter [mm]): hazel 6, alder 5, birch 10, oak 3, grass-mix 3, mugwort 3.

In vitro testing: Total IgE 10 kU/L, specific IgE to Bet v 1: 3.4 kU/L (>1/3 of total IgE indicating strong sensitization), Phl p 1: 2.8 kU/L, other allergen specificities Phl p 12 (profilin), Art v 1, mugwort, Pru p 3 (nsLTP) negative (<0.1 kU/L).

Diagnosis: (A) Allergic rhinoconjunctivitis due to Fagales tree pollen; (B) Bet v 1-associated food allergy (oropharyngeal symptoms to raw foods). Recommendations: Allergen-specific immunotherapy with birch extract. Avoidance of raw Bet v 1-cross-reactive pome and stone fruits (see subject's history).

Comments: (a) Absolute IgE values (total and allergen-specific) are both low; (b) relative relationship between Bet v 1-specific IgE and total IgE is high (pointing to the need to consider both, total and specific IgE, for proper interpretation); (c) *certain fruits are not primarily regarded as containing Bet v 1-homologues, but rather as nsLTP-containing foods; but, due to negative IgE to Pru p 3 and profilin, these reported reactions cannot be easily explained. A Bet v 1 homologue may well be described in blueberries and grapes in the future.

Case 3 (original, #6213):

History: Female, 47 yrs: Since 15 years after consumption of raw plant foods like apples, cherries, hazelnuts, walnuts within 1 minute mild sore throat for 5 minutes. So far, no allergic symptoms during spring.

In vitro testing: Total IgE 174 kU/L, specific IgE to Bet v 1: 34 kU/L.

Diagnosis: Bet v 1-associated food allergy (oropharyngeal symptoms to raw foods) without allergic airway disease. Recommendations: Avoidance of raw Bet v 1-cross-reactive pome and stone fruits (see subject's history). No indication for AIT due to missing Fagales tree pollen induced airway symptoms.

Comments: Rare cases are suffering from oropharyngeal allergy symptoms due to plant foods containing Bet v 1-homologues without any allergic airway symptoms during the birch pollen season. Diagnosis is established by IgE testing to Bet v 1. Potential clinical consequences are addressed "clinically" (without further IgE testing to other Bet v 1-homologues).

C03 – Nonspecific lipid transfer proteins (nsLTP)

Elide Anna Pastorello, Francisca Gomez, Domingo Barber

Highlights

- Nonspecific lipid transfer proteins (nsLTP) are the most prevalent plant-food allergens in Southern Europe.
- The clinical reactions can be systemic and severe, especially when not associated to birch pollinosis.
- Pru p 3, the major allergen of peach, plays a precursor role in the sensitization to other nsLTP.
- Relevant nsLTP containing plant-foods belong not only to the *Rosaceae* family but also to the nut group and to cereals, such as wheat, maize, and rice.

1 – The protein

Pru p 3, the major allergen of peach, was the first nsLTP to be fully identified and characterized as a relevant food allergen. It is the most broadly recognized allergen of the family; however, there are patients sensitized to nsLTP that might not be sensitized to Pru p 3. It is in vascular tissue and in the outer cell layers of the plant organs and it essentially concentrates in the pericarp of fruits, whereas the pulp contains levels around 220-fold lower than peel. Peach fuzz contains large amounts of Pru p 3. It is a small basic protein of 91 amino acids, with a molecular weight of 9,178 Da. It contains a highly conserved domain consisting of alpha-helices that harbor eight cysteine residues, a distinctive sign of belonging to the Prolamin superfamily. The cysteine residues form four intramolecular disulphide bridges, which makes the protein resistant to high temperature and pH changes. The four disulphide bridges are responsible for the LTP compact folding, which forms a tunnel-like hydrophobic cavity running through the whole molecule. The Pru p 3 molecule is very flexible; therefore, the volume of the inner cavity can change significantly, and the protein can bind various lipidic ligands. The changes of the allergen conformation, which are related to ligand binding, alter the protein surface and this can modify its IgE-binding properties. This has been proposed for Pru p 3, where using an *in silico* approach, only the binding with oleic acid and not with stearic acid conditioned the exposure of the C-terminal loop that is a major IgE-binding epitope thus increasing the IgE-binding properties of this molecule.⁴⁸² Moreover, the natural ligand of Pru p 3 has been recently identified as a derivative of the alkaloid camptothecin bound to phytosphingosine.⁴⁸⁴ This ligand acting as an adjuvant strongly increases the sensitizing capacity of Pru p 3 via CD1-mediated activation of invariant Natural Killer T-cells (iNKTs). Interestingly the structure of Pru p 3 presents significant structural similarities to saposins, small molecules that assist the loading of lipids onto CD1d.⁴⁸⁵ LTP is expressed at two key times of

flower and fruit development in peach, namely, during pollination and during embryo development. Figure 150 shows the crystal structure of Pru p 3 (Table 80). Three IgE-binding epitopes on the LTP molecule have been identified: Pru p 3₁₁₋₂₀, Pru p 3₃₁₋₄₀ and Pru p 3₇₁₋₈₀. These peptides are shared with other fruits including apple, apricot, plum, cherry, orange, strawberry, grape, with a sequence identity ranging from 62 to 81%.¹⁴⁵⁰ Pastorello et al.¹⁴⁵¹ also identified two immunodominant T-cell reactive regions, that have been called Pru p 3₁₂₋₂₇ and Pru p 3₅₇₋₇₂. These peptides have the ability to induce the production of IL-4 by Pru p 3-specific T cells after allergen-specific stimulation, reflecting a Th2-dominated response. The stable tertiary conformation of Pru p 3, provides resistance to thermal degradation. *In vitro* IgE-binding ability is maintained after 30 min at 121°C and after 160 min at 100°C. Pru p 3 is as well resistant to proteolytic digestion. After a proteolytic treatment with trypsin, 35% of the molecule remains intact. After proteolysis, three high molecular weight (HMV) peptides and the peptide Pru p 3₅₇₋₇₂ are released. These peptides have still IgE- and T-binding ability and thus have the potential to either sensitize or induce an allergic reaction.¹⁴⁵²

2 – The family

Pru p 3 belongs to the family of nonspecific Lipid Transfer Proteins (nsLTP), which includes allergens most frequently involved in food allergic reactions in the adult population from the Mediterranean area.¹⁶⁹⁸ LTP belong to the superfamily of Prolamins including several families like alpha-amylase inhibitors; 2S albumins and nsLTP. All members of the prolamin superfamily share the conserved pattern of eight cysteine residues; nsLTP as a difference to other members of the superfamily are not restricted to seed tissues but ubiquitously expressed throughout the plant.

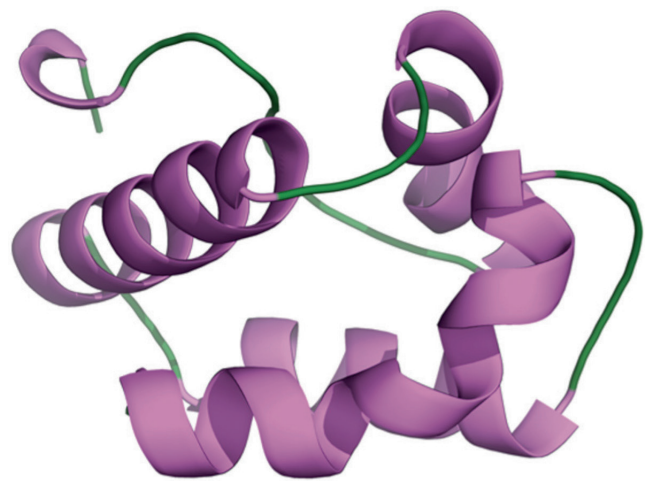


FIGURE 150 Crystal structure of peach Pru p 3, prototypic member of the family of plant nonspecific lipid transfer protein pan-allergens. Protein chains are colored. The figure was generated using PyMOL Molecular Graphics System v1.6.

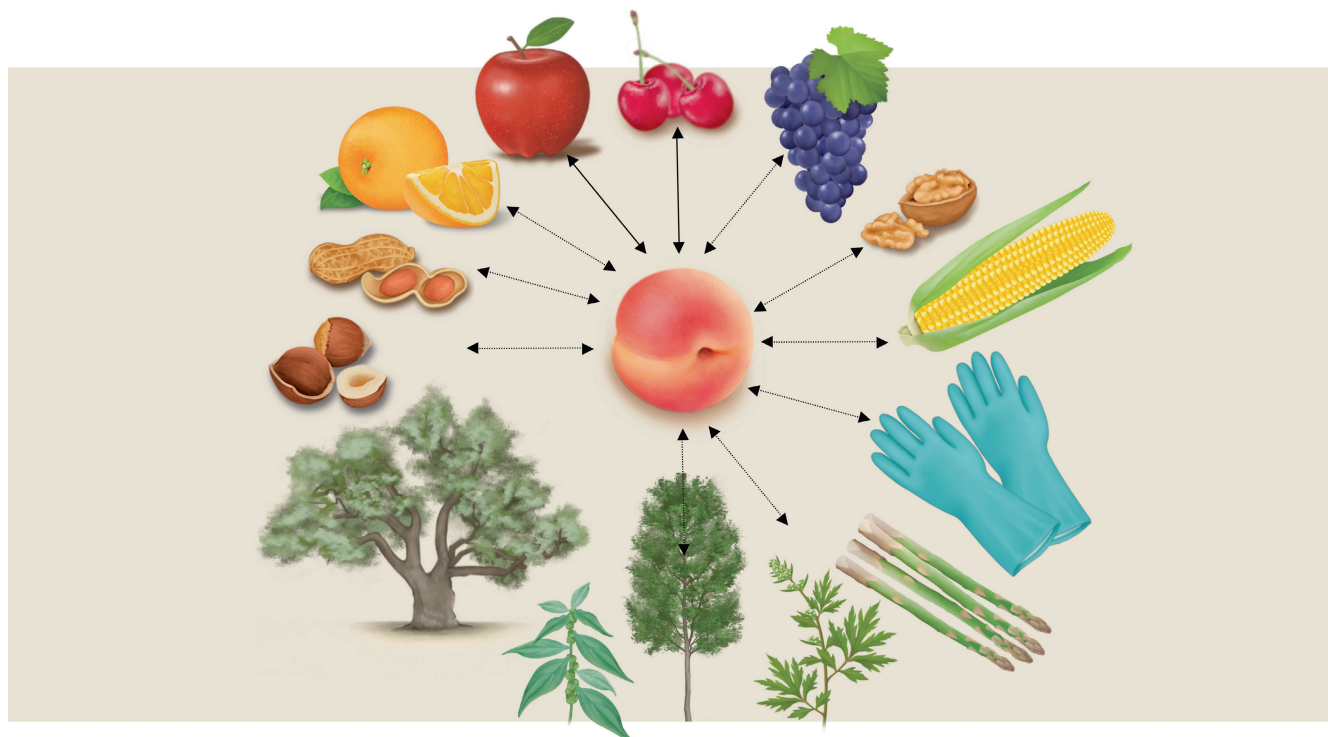


FIGURE 151 Cross-reactivity due to nsLTP molecules between different allergenic sources. Continuous lines indicate a high degree of cross-reactivity among the *Rosaceae* family. Dashed lines indicate partial cross-reactivity.

TABLE 80 Protein characteristics

Protein characteristics	
Allergen source	<i>Prunus persica</i> , peach
Protein family	Lipid Transfer Proteins
UniProtKB accession No.	P81402
Crystal available	Yes
Molecular structure	Mainly alpha-helix
Molecular weight	9,178 Da
Length	91 amino acids
Ligand binding	Mainly hydrophobic ligands
Dimerization	No
Glycosylation	No
Disulfide bonds	4
Isoelectric point	9.25
Distribution	Seeds, fruits, leaves, roots, pollens

LTP concentration is variable and depends on maturity, storage conditions, and cultivar of the fruit. Besides nsLTP have a role in the transport of hydrophobic molecules that compose the cutin and suberin layers of plant tissues. It has been suggested that nsLTP could be involved in plant defense against bacterial and fungal pathogens, and therefore they are also classified as Pathogenesis-Related Proteins type 14, (PR-14). Following the line of studies with Pru p 3, it has been shown that natural ligands transported by other allergenic LTP such as those from *Triticum aestivum* (wheat), *Artemisia vulgaris* (mugwort), *Parietaria judaica* (pellitory of the wall) and *Olea europea* (olive) were similar to those transported by Pru p 3. The authors also

demonstrated that Phytosphingosin could act as a functional analogue of human SPH (sphingosine) being converted by the epithelial enzyme SphK1 into PHS1P, a phosphorylated metabolite analogue of S1P that plays a significant role in the pathogenesis of asthma and allergy.^{483,1698} To date, the International Union of Immunological Societies Allergen Nomenclature Sub-committee lists 46 allergenic LTP molecules originated from fruits, pollen of trees and weeds, vegetables, nuts, and seeds, as well as latex. (Figure 151) based on their molecular mass, nsLTP are grouped into two types, LTP1 (9–10 kDa; around 90 amino acids) and LTP2 (6–7 kDa; around 70 amino acids). However, the majority of allergenic nsLTP belong to the nsLTP1 type. The most characteristic members are included in (Table 81). LTP are the most important allergens of the *Prunoideae* subfamily such as peach, apricot, plum and cherry. IgE cross-reactivity has been observed within the *Rosaceae* family (high degree) and with citrus fruits, grape, tomato, vegetables (asparagus, lettuce, etc.), nuts (hazelnut, walnut, peanut, etc.), maize, onion, carrot, rice, and spelt (partial cross-reactivity).⁴⁸⁵ The Arg39/Thr40 epitope is well conserved in *Rosaceae* nsLTPs and only partly in cereal nsLTP (Figure 153). Besides, relevant allergens from *Parietaria*, *Artemisia*, *Platanus* and *Olea* pollen are also members of the LTP family, but they show rather low (*Artemisia* and *Platanus*) or absent (*Parietaria* and *Olea*) cross-reactivity with Pru p 3 as a consequence of the lower sequence identity (<35%), and different length.¹⁴⁵¹ (Figure 154) shows conserved and divergent residues between *Rosaceae* nsLTP (A) and sequence identity between Pru p 3 and Art v 3 (B) or Ara h 9 (C). Recently Skypala et al., have reviewed extensively the different aspects of nsLTP structure, cross-reactivity and epidemiology.³⁵

TABLE 81 Representative members of the nsLTP family and cross-reactivity between them

Botanical family	Allergen source	Allergen
Plant foods		
<i>Rosaceae</i>	Peach (<i>Prunus persica</i>)	Pru p 3
	Apple (<i>Malus domestica</i>)	Mal d 3
	Cherry (<i>Prunus avium</i>)	Pru av 3
<i>Vitaceae</i>	Grape (<i>Vitis vinifera</i>)	Vit v 1
<i>Rutaceae</i>	Orange (<i>Citrus sinensis</i>)	Cit s 3
<i>Solanaceae</i>	Tomato (<i>Lycopersicon esculentum</i>)	Lyc e 3
<i>Corylaceae</i>	Hazelnut (<i>Corylus avellana</i>)	Cor a 8
<i>Juglandaceae</i>	Walnut (<i>Juglans regia</i>)	Jug r 3
<i>Fabaceae</i>	Peanut (<i>Arachis hypogaea</i>)	Ara h 9
<i>Asteraceae</i>	Lettuce (<i>Lactuca sativa</i>)	Lac s 1
<i>Poaceae</i>	Maize (<i>Zea mays</i>)	Zea m 14
	Wheat (<i>Triticum aestivum</i>)	Tri a 14
Occupational allergens		
<i>Euphorbiaceae</i>	Latex (<i>Hevea brasiliensis</i>)	Heb b 12
<i>Asparagaceae</i>	Asparagus (<i>Asparagus officinalis</i>)	Aspa o 1
Pollen		
<i>Urticaceae</i>	Parietaria (<i>Parietaria judaica</i>)	Par j 1
<i>Asteraceae</i>	Ragweed (<i>Ambrosia artemisiifolia</i>)	Amb a 6
	Mugwort (<i>Artemisia vulgaris</i>)	Art v 3
<i>Oleaceae</i>	Olive (<i>Olea europaea</i>)	Ole e 7
<i>Platanaceae</i>	Plane (<i>Platanus acerifolia</i>)	Pla a 3

A complete list of described allergenic LTPs can be found at: <http://allergen.org/>

3 – Clinical relevance

Clinically relevant nsLTP have been described both in foods and pollens. The real frequency of LTP sensitization in Europe is unknown, however, in an epidemiological survey performed in Spain^{280,585} on pollen allergic patients, Pru p 3 sensitization affected 11% of the adults and 22% of the children tested. These data suggest that approximately 2% of adults and 4% of children show positive sIgE to Pru p 3 (assuming a 20% prevalence of pollen allergy). Approximately 50% of the patients that were sensitized to Pru p 3 referred food allergy. Considering the patients that are not pollen allergic and exclusively LTP-sensitized, the LTP-syndrome represents the most frequent type of food allergy in adults and adolescents in Southern European countries. By contrast, this syndrome shows a low prevalence in Central and Northern Europe. From a clinical point of view, the LTP-syndrome presents some peculiar aspects, which need to be known for the appropriate management of LTP allergic patients.

3.1. Clinical reactivity

A remarkable feature of LTP sensitization is the high variability of its clinical presentation, ranging from mild contact urticaria to anaphylaxis.^{1454,1455,1699} Different studies described the robust association between Pru p 3 positivity and the severity of systemic allergic symptoms. Even recently, in a component-resolved diagnosis based (CRD) study conducted on an adult cohort of 54 patients with a history of plant-food allergen-induced anaphylaxis, the authors found

that nsLTP were one of the most frequent causes of anaphylaxis.¹⁴⁵⁵

In most of the cases systemic symptoms are preceded by oral allergy syndrome (OAS) manifestations, probably because the route of exposure is the oral mucosa. The severity of the reaction seems to be higher when patients are mono-sensitized to LTP and milder when patients are also sensitized to profilin or PR-10.¹¹²⁸ level of specific IgE to Pru p 3 does not correlate with the severity of reactions. Patients can present restricted IgE recognition to one LTP or a broad recognition spectrum (LTP syndrome). Moreover, the most severe reactions are frequently associated to different co-factors such as NSAIDs intake or exercise.¹⁴⁵⁴

3.2. Geographical differences

Another peculiar aspect of the LTP-syndrome stems from the clear-cut geographical difference in sensitization. The severe LTP-induced clinical manifestations seen in Mediterranean populations are usually in contrast to mild clinical manifestations of the oral allergy syndrome that are associated to Birch pollen allergy caused by Bet v 1 and Bet v 2 sensitization in Central and Northern Europe. In a peach allergy model, patients were prone to suffer severe reactions in areas with low level of Fagales pollen, usually non pollen allergics, while pollen co-sensitized subjects presented milder symptoms induced by Pru p 3. This finding also has been confirmed by other Authors in an apple model.¹⁴⁴⁹ In a European collaborative study on apple allergy, Mal d 3 sensitization was significantly more frequent in Spain, an almost birch-free area, as compared to birch-rich countries such

as Netherland, Austria and northern Italy.^{35,1449} These correlations suggest that Birch pollen exposure, typical of Central and Northern European populations, may confer a sort of immune protection to LTP sensitization. Recently the role of LTP as food and pollen allergens even outside the Mediterranean area has been reviewed and demonstrated to be expressed in different phenotypes depending upon the sources and the intensity of exposure.³⁵ In general the sensitization pattern to LTP outside the Mediterranean area differs from that of Southern Europe, with an overall lower prevalence and an apparent association to pollen cross-reactive LTP.^{35,1449} A typical example is the cross-reactivity between Pru p 3 and Art v 3 in China.¹²⁵⁵

3.3. Pediatric patients

Children sensitized to Pru p 3 present clinical symptoms earlier than those sensitized to other pollen related allergens.¹¹⁴⁸ In a clinical study carried out in Italy in adults, a total of 26 out of 48 subjects that were Pru p 3 positives alone, presented peach-related allergy symptoms between 2-15 years, earlier than those sensitized only to Pru p 1 and/or Pru p 4 allergens. Furthermore, in the same patients, Pru p 3 sensitization correlated with the development of allergic reactions to a higher number of plant-foods than Pru p 1 and Pru p 4 sensitization alone.

3.4. Role of Pru p 3

Peach is the most frequent cause for nsLTP allergy, and Pru p 3-sensitization seems to play a precursor role in the sensitization to other nsLTP. The most frequently involved plant-foods are fruits of the *Rosaceae* family such as apple, plum, apricot, cherry and pear. However, there are also botanically unrelated LTP-containing plant foods that appear to be strongly associated with peach, particularly, in the nut group: walnut, hazelnut and peanut have been described as foods eliciting not only OAS but also severe systemic reactions in LTP-sensitized subjects. Also, the most important cereals such as wheat, maize and rice can cause systemic reactions of various grades of severity as confirmed by double-blind placebo-controlled food challenge (DBPCFC) in LTP-allergic patients. In particular wheat has been recently described as cause of exercise related anaphylaxis in three young LTP-sensitized patients. LTP allergens also have been identified in green bean, fennel, orange, kiwi and lentil when using the sera of allergic patients previously sensitized to peach LTP. A large number of the aforementioned studies have indeed demonstrated that Pru p 3-sensitization dominates the immune response to LTP in the other foods and that peach is almost always the food initiating the LTP allergy syndrome. However, clinical reactivity is not invariably a direct consequence of the cross-reactivity.^{35,1449} In many cases LTP-containing, Pru p 3 cross-reactive foods can be tolerated. Recently, an alternative sensitization route has been reported, independent from Pru p 3, connected to marijuana inhalation mediated by Can s 3, the nsLTP from Cannabis sativa.³⁵

3.5. nsLTP and respiratory allergens

As shown in Table 81, nsLTP have been identified as major and minor allergens in different tree and weed pollens. It is worth to

point out that frequently airborne sensitization to pollen LTPs is associated with more severe clinical phenotypes. Parietaria pollen is the only pollen with a nsLTP as the major allergen. Accepted threshold pollen levels for sensitization are low and clinically, Parietaria pollinosis is often linked to asthma. Ole e 7, the nsLTP from olive pollen, has been reported to identify a severe allergic olive pollen phenotype, with increased risk of asthma and side-reactions during immunotherapy. In areas of heavy olive pollen exposure this allergen can sensitize up to 50% of pollen-allergic population.⁵⁸⁵ It has been recently reported that Ole e 7 could play a new role as primary sensitizer in these areas, leading to peach nsLTP sensitization. This co-sensitization process would occur because of the cross-reactivity between Ole e 7 and Pru p 3 observed in some allergic patients.¹⁴⁵⁶ Art v 3 and Pla a 3, are minor pollen allergens and display partial cross-reactivity with Pru p 3 (Figure 152). As a consequence, sIgE to either *Artemisia* or *Platanus* should always be considered for potential cross-reactivity and should be assessed in connection with major pollen allergens and Pru p 3. In areas with high *Platanus* or *Artemisia* exposure, sensitization to these pollen LTP has been associated with a more complex recognition pattern in nsLTP food allergic patients.¹⁴⁵⁷ It has also been reported that Pru p 3 is able to induce respiratory symptoms in areas with extensive orchard tree cultivation.³⁵ Further, asparagus nsLTP has been described as an occupational allergen able to induce respiratory symptoms.¹⁴⁵⁸ As previously mentioned, Can s 3, the ns LTP from Cannabis can induce respiratory allergy.³⁵

4 – Clinical management

4.1. Identification of clinically relevant allergens

The clinical history should be aimed first at identifying reactions to plant-foods most frequently involved in typical reactions of the LTP syndrome (Figure 153). Primarily peach, apple and other *Rosaceae* fruits and second a group of seeds that frequently are linked to LTP allergy as walnut, hazelnut, peanut, maize, wheat rice, or other beans. However, it should be taken into account that LTP are present in all vegetable tissues and can always be etiological proteins in vegetable-mediated allergies. In spite of this, the presence of nLTP in a plant-food is not a reason to avoid it if tolerated until that moment as the contact with the intestinal immune system may help in maintaining tolerance. A list containing the nsLTP-rich foods should be avoided and the situation for each single food should be evaluated before its exclusion.

4.2. Role of cofactors

A second critical point of the diagnosis is the consideration that severe reactions might be linked to cofactors such as exercise, alcohol intake, anti-acids and NSAIDs and thus LTP potential involvement should also always be evaluated associated to those.¹⁴⁵⁴ A third point to consider is that many times severe LTP-associated clinical reactions take place in patients that are not pollen allergic.

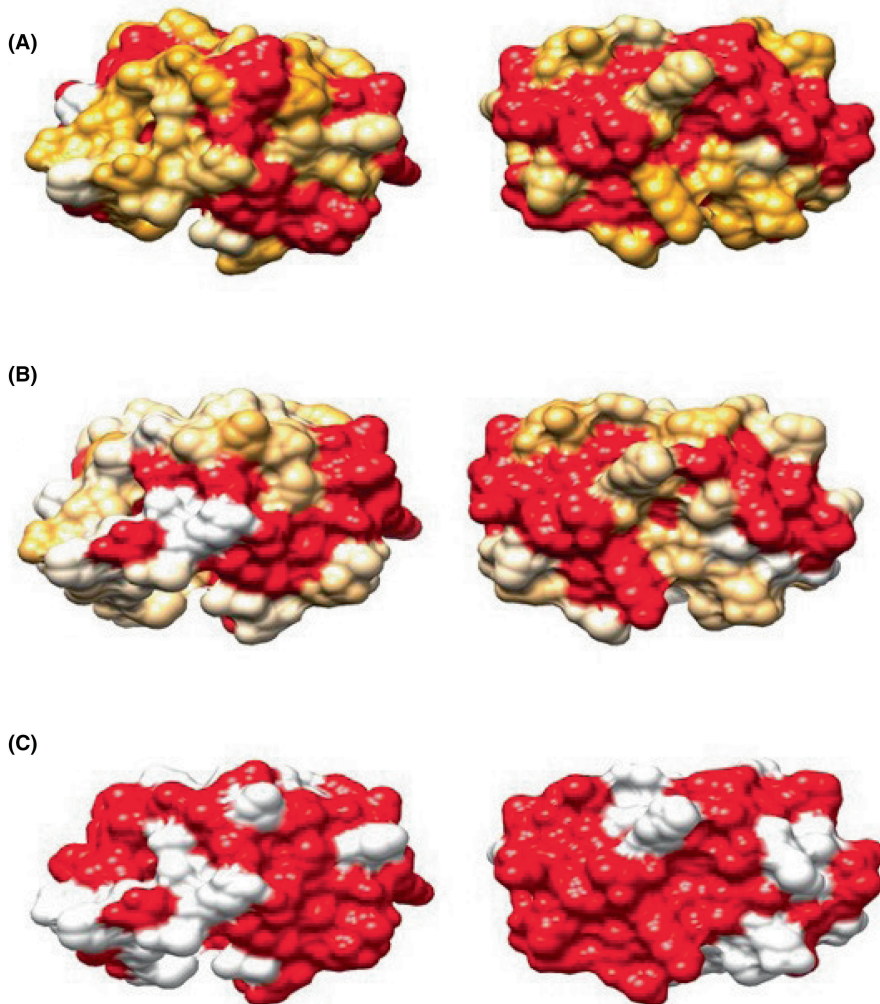


FIGURE 152 Homology between members of the nsLTP family. (A) Surface residues on Pru p 3 conserved among 8 *Rosaceae* fruit nsLTP proteins. Red: residues conserved in 90% or more proteins. Orange: residues conserved in 40-90% of the proteins (gradient); White: residues conserved in less than 40% of the proteins. (B) Surface residues conserved among Pru p 3 and 4 isoforms of Art v 3. Red: residues conserved in 90% or more Art v 3 isoforms. Orange: residues conserved in 40-90% Art v 3 isoform (gradient). White: residues conserved in less than 40% Art v 3 isoform. (C) Surface residues conserved among Pru p 3 and Ara h 9. Red: residues conserved in Pru p 3 and Ara h 9. White: no conserved residues

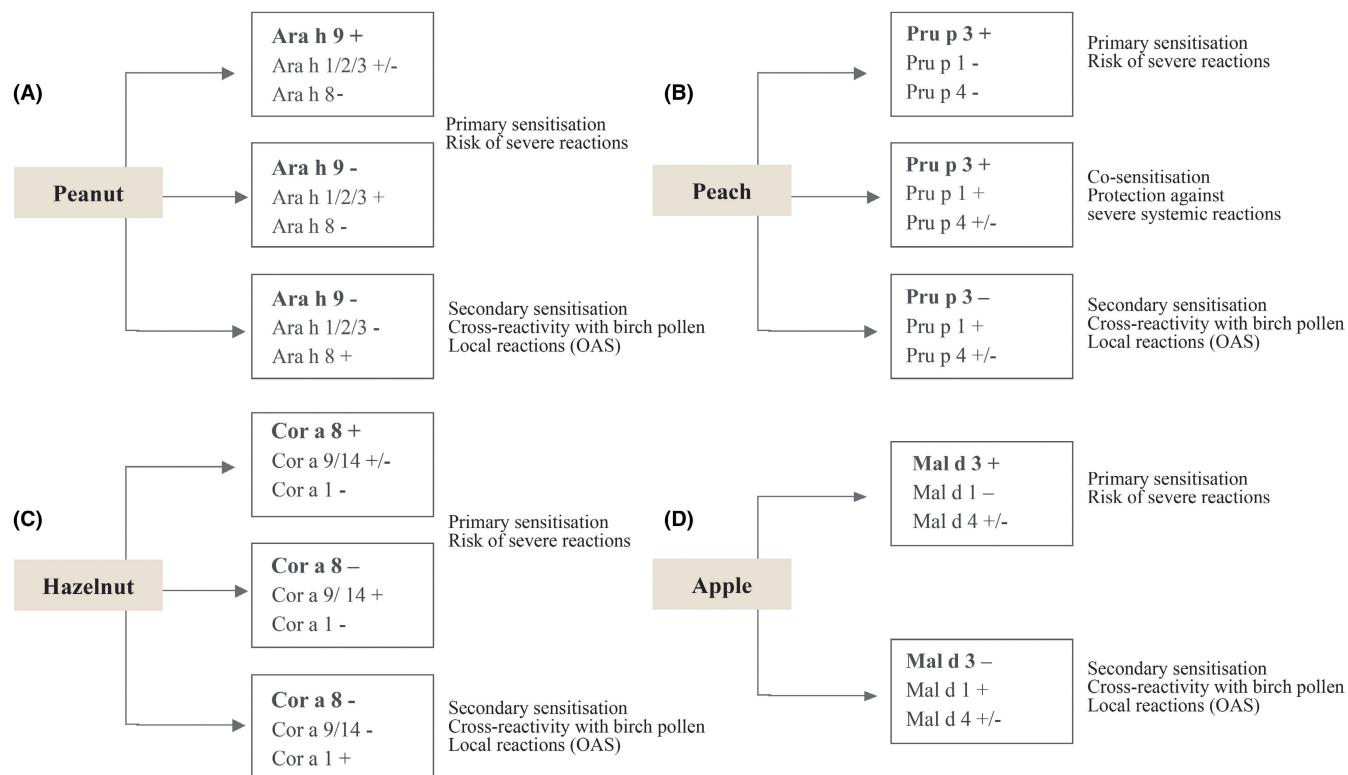


FIGURE 153 Diagnostic algorithms using molecular IgE diagnostics in the case of positive SPT/extract-based IgE test to (A) peanut; (B) peach; (C) hazelnut or (D) apple. LTP allergens are displayed in bold.

4.3. Component-resolved diagnosis (CRD)

Positive skin tests and/or extract specific IgE confirming plant-food sensitization should be further investigated by CRD. Skin prick tests with commercial extracts, and prick-to-prick with fresh vegetable foods should be performed according to European guidelines. Prick-to-prick testing with fresh fruits and vegetables has proven to be more sensitive than SPT with commercial extracts in confirming a history of food allergy to plant-foods. In order to test for LTP sensitization, nsLTP enriched allergenic commercial extracts of apple and peach are now available on the market. They can be useful for the identification of a large number of LTP sensitized patients, as Pru p 3 has proven to be pivotal in LTP syndrome. However, Pru p 3 cannot be considered a general marker of clinical LTP-allergy. As previously mentioned, it shows very limited sequence homology with pollen LTP, such as Par j 1 or Ole e 7, which implicates a very low risk of cross-reactivity. Other LTP such as Tri a 14 connected to baker's asthma, has proven to be an independent sensitizer as well.¹⁴⁵⁹

The key-role of nsLTP as a marker of true food allergy with a high risk of severe systemic reactions, as compared to food allergy (i.e., OAS) due to Bet v 1 and Bet v 2 homologues in birch allergic patients, has prompted the development of assays for detecting anti-LTP specific IgE (ImmunoCAP Specific IgE test) in the diagnosis of plant-foods allergy.

In peach, the simultaneous presence of both, anti-Pru p3 and anti-Pru p1 IgE antibodies seems to lower the risk of severe food allergic reactions.¹⁴⁶⁰ This observation has been confirmed by Ruano Zaragoza et al.¹⁴⁶¹ who found in a population of 431 Pru p 3-sensitized patients that Pru p 1 or Phl p 12 positivity was negatively associated with development of anaphylaxis. Similarly, Mota I et al.¹⁴⁶² found in a group of 43 LTP sensitized patients that the co-sensitization to plant food allergens belonging to PR-10 family could be a preventing factor able to reduce the severity of LTP allergy. In an analysis of severity biomarkers, Bogas G et al. found that profilin positive patients had statistically fewer anaphylactic events compared to patients sensitized exclusively to LTP.¹¹²³ All these data clearly demonstrate the important role of CRD in the diagnosis of LTP syndrome and in phenotyping with regard to severity. The identification of IgE cut-off values correlating with symptom severity could highly increase the efficacy of diagnosis. At present, nine different nsLTPs are available in ImmunoCAP ISAC and fifteen in MADX from Macro Array Diagnostics. The clinical relevance of testing these panels to predict the clinical reactivity pattern is still subject of active research. As a difference to other pan-allergen allergies, it would be necessary to incorporate a broader nsLTP panel for making a correct patient diagnosis. In this context the broad panel offered in MADX provides a new tool to investigate nsLTP allergy. Pru p 3 seems to play a central role in nsLTP-mediated reactions. *In vivo* and *in vitro* diagnostic tools for Pru p 3 are commercially available and their inclusion in general patient screening is advisable, especially in geographic areas where the prevalence of nsLTP sensitization is considerable.

4.4. DBPCFCs for LTP-containing plant-foods

The double-blind placebo-controlled food challenge (DBPCFC) is the diagnostic gold standard in food allergy. In routine clinical practice, if multiple challenge tests are not feasible, DBPCFCs for LTP-containing plant-foods should be performed for the most nutritionally relevant or widely consumed foods to minimize unnecessary exclusion from the diet. In some cases, the challenge test should also be performed after exercise given that LTP have been described as foods involved in food-dependent exercise-induced anaphylaxis (FDEIA).¹⁴⁶³

4.5. Diagnostic algorithms

Many patients show a progressive clinical recognition of LTP. In some cases, they might be obliged to avoid almost any vegetable. The complexity and intensity of IgE repertoires to the panel of LTP might predict this evolution and is being today a subject of active research.

4.6. Treatment

The possibility of desensitization has been explored.⁴⁰¹ In an open controlled study,¹¹⁸¹ 90% of treated patients with a sublingual peach extract vaccine, tolerated a whole peach after one year of treatment. Before, about 50% of the patients included had anaphylactic reactions, suggesting that immunotherapy might be a feasible option for the treatment of severe LTP allergy. Moreover, evaluating the effect on concomitant allergy mediated by peanut LTP (Ara h 9), the authors reported a significant clinical benefit, supporting that Pru p 3 can be used for treatment of LTP syndrome. The same authors analysed immunological changes induced by the therapy supporting an induction of a regulatory response to both peach and peanut. A diagnostic algorithm and decision tree for allergen immunotherapy using CRD in nsLTP-mediated allergies has been recently proposed.¹⁴⁶⁴ Unfortunately, this therapy is only available in a limited number of countries. The prescription of adrenaline autoinjectors in cases of previous reactions and in severe risk patients is recommended. An extensive review on the diagnosis and clinical management of LTP allergy has been recently published.¹⁴⁵⁴

5 – Clinical cases

Case 1 (published)¹⁷⁰⁰

Male, 17 years with a 12-year history of peach induced systemic symptoms and sporadic anaphylaxis of unknown origin. Specific IgE were positive for rPru p 3 (34.7 kU/L), while moderate for wheat (1.56 kU/L), maize (4.92 kU/L) and rice (1.46 kU/L). sIgE to omega 5 gliadine was negative. IgE immunoblotting was positive for LTP in the three cereals. Wheat Open Exercise Food Challenge (OEFC) gave rise to an anaphylactic reaction treated with Epinephrine. Rice and maize OEFC were negative. Wheat-free diet allowed the patient to perform agonistic physical activity without any symptoms. He did

not need to eliminate rice and maize from his diet. Thus, LTP sensitization to rice and maize was due to cross-reactivity with Pru p3. The message is that the challenge is advisable to avoid unnecessary food elimination.

Case 2 (unpublished real case)

Female, 52-years old with a 32-year history of peach-peel induced contact urticaria and immediate abdominal pain after peach-juice ingestion. She avoided this fruit since the reaction. The patient tolerated other fruits, vegetables, and tree-nuts. After some time, the patient developed a systemic reaction after eating a complete unpeeled apple (generalized urticaria and angioedema). Soon after she referred oral allergy syndrome with walnut, hazelnut and almond and she avoided other nuts as peanuts for fear of having a new reaction.

The patient had a clinical history of allergic rhinitis to olive pollen since she was 15 years old. SPT to aeroallergens was positive for olive, mugwort, plane-tree pollen and HDM. SPT to plant-food was positive to peach peel, apple, hazelnut, almond and peanut. Specific IgE were positive for rPru p 3 (21.50 kU/L), for walnut (21 kU/L), hazelnut (10.20 kU/L) and peanut Ara h 9 (11.5 kU/L); and negative for peanut Ara h 2. We carried-out a peeled apple (154 g) open food challenge and the patient presented lips angioedema after 70 g of the total dose. She was treated with oral loratadine, and the reaction was resolved.

The patient participated in the clinical study with Pru p 3 SLIT with a commercialized peach extract enriched in Pru p 3 (50 µg/mL) (ALK-Abello S.A.). At the inclusion visit, we performed a DBPCFC with unpeeled peach, (300 mL that is a total dose of 2.5 mg of Pru p 3) and peanut (15 units) The patient presented lips angioedema and OAS after 50 mL of peach juice and oral allergy symptoms with VAS of seven with three consecutive dose of peanut (total of seven fried peanut nuts). The patient was included on a clinical trial and was treated during a year with Pru p 3 SLIT, receiving a 10µg daily dose of Pru p 3. After 12 months of treatment, we observed a mild decrease in the size of papule for peach (10mm area before Pru p 3-SLIT to 6mm area after Pru p 3-SLIT) but not to peanut. We observed a decrease in sIgE to Pru p 3 (12.3 kU/L) and peanut (6.10 kU/L). During the DBPCFC with peach, the patient tolerated the maximum amount of juice and peanut (15 units).

We recommended to include peach and peanut in a free diet (taking the maximum dose tolerated during DBPCFC). This is a clinical case of a patient suffering from LTP-Syndrome, in which SLIT-Pru p 3 has provided an improvement in tolerance not only for peach but also for other foods related to LTP sensitization such as peanuts. After the study the patient continued with the SLIT for two years and we performed OFC with the other nuts (hazelnut and almond) and unpeel-apple, that were introduced in the diet. The patient refused the oral food challenge with walnut.

Case 3 (unpublished real case)

Male, 30-year with a 24-years old history of peach-peel induced contact urticaria. He avoided this fruit since the reaction. The patient tolerated other fruits, vegetables, and tree-nuts. Ten years after first symptoms, the patient developed a systemic reaction after ingestion of walnut, hazelnut, and peanut (hives, angioedema, shortness of breath, dizziness). Since the reaction with these nuts, the patient avoided all types of tree-nuts, including pistachio and cashew. SPT to aeroallergens was positive to mugwort and plane-tree pollen. SPT to plant-food was positive to peach peel, hazelnut, and peanut; and negative to almond, pistachio, and cashew. Specific IgE were positive for rPru p 3 (20.6 kU/L), moderate for walnut (4.93 kU/L), hazelnut (0.54 kU/L) and peanut Ara h 9 (15 kU/L); and negative for peanut Ara h 2. Almond Open Food Challenge was positive with a total dose of 5 units of fried almond, presenting the patients oral allergy syndrome and lip angioedema that was treated with IM dexchlorpheniramine. Pistachio and cashew OFCs were negative. Upon DBPCFC with unpeeled-peach and peanut, the patient presented OAS and abdominal pain at intermediate peach dose as well as lips angioedema, erythema, and pruritus after 5 units of fried peanut. The patient was included on clinical study and was treated during a year with Pru p 3-SLIT (as in case 2). After 12 months of treatment, we did not observe a decrease in the peach or peanut wheal size, but we observed a decrease in the levels of sIgE to Pru p 3 (10.5 kU/L); and peanut (4.3 kU/L). During the DBPCFC with peach the patient tolerated all the amount of juice and peanut (15 units). This is a clinical case of a patient that developed an LTP syndrome, in which Pru p 3-SLIT induced an improvement in tolerance not only of peach but also of other foods related to LTP sensitization such as peanuts. Currently the patient tolerates other nuts as walnut and hazelnut.

6 – Tools

CRD by SPT is possible by using peach extracts highly enriched on Pru p 3, (with very low content of other allergens).¹⁴⁵³ As most of the patients with nsLTP-mediated food allergic reactions will be positive to Pru p 3, this extract should be used in a general screening for inhaled as well as food allergy. Complex nsLTP syndrome patients will eventually react to multiple members of the family. Today, there are different alternatives for multiple testing of sIgE to LTPs: FABER, ALEX, and ImmunoCAP ISAC112. The latter contains 9 different LTP: Pru p 3, three nuts LTP (Ara h 9, Cora a 8, Jug r 3), one cereal flour LTP (Tri a 14) and four pollen LTP (Art v 3, Ole e 7, Pla a 3 and Par j 2) and has been widely used in the last years.

The sIgE responses to the above mentioned LTP panel could be a reflection of the extension of LTP family recognition and therefore related to severity of the LTP syndrome and the probability of future side reactions to new fruits and vegetables. However, to date there is no validated approach or threshold values for sIgE levels. The individual allergens are also available in the ImmunoCAP Specific IgE test.

C04 – Serum albumins

Maksymilian Chruszcz, Martine Morisset, Christiane Hilger

Highlights

- Highly conserved sequences with high amino acid sequence identity
- Minor respiratory allergen of animal dander
- Food allergen of milk and meat
- Allergen implicated in pork-cat and bird-egg syndrome

1 – The protein

Bos d 6, Bovine serum albumin (BSA), is a well-characterized protein (Table 82).¹⁴⁶⁵ It is synthesized in the liver and is a major component of plasma. BSA is widely used in biochemical and immunological assays as well as in vaccines, surgical adhesives, hemostatic tissues, and it is a common cell culture ingredient.

The protein architecture of Bos d 6 was resolved in 2012¹⁴⁶⁵ and revealed an α -helical structure composed of three structurally similar domains arranged into a heart-shaped form (Figure 154). The molecule is stabilized by seventeen disulfide bonds. Bos d 6 is denatured by heating to temperatures above 50°C. Helices are partially disrupted and heat-induced aggregation takes place at 60°C.¹⁴⁶⁶

Bos d 6 is a respiratory and food allergen as it is present in bovine dander, milk, and meat. BSA is classified as minor allergen in animal dander, but it is an important meat and milk allergen in the case of uncooked food ingestion. Since Bos d 6 is a thermolabile protein, well-done meat and boiled milk are safe for allergic patients (for details, see chapters on Allergy to furry animals, Allergy to meat, and Allergy to milk).⁴⁷⁷ There is currently no assay available for quantification of Bos d 6 in the environment.

Family characteristics

- Common tertiary α -helical structure
- Highly conserved sequences with high amino acid sequence identity
- Large secreted molecules of 65 - 69 kDa
- Bind many small molecular compounds
- Thermolabile
- Present in dander, secretions, and meat

2 – The family

Serum albumins are large globular proteins synthesized in the liver.¹⁴⁶⁷ They are abundant in plasma and contribute to the

TABLE 82 Characteristics of the prototype protein

Protein characteristics	
Allergen source	<i>Bos domesticus</i> , domestic cattle
Protein family	Serum albumin
UniProtKB accession	P02769
Crystal structure	Yes
Molecular structure	Mainly helical
Theoretical molecular weight	66.56 kDa
Length	607 amino acids; mature protein: 583 amino acids
Ligand binding	Yes
Dimerization	No
Glycosylation	No
Disulfide bonds	17
Isoelectric point	5.6
Synthesis	Liver, secreted
Distribution	Plasma, dander, saliva, milk, meat

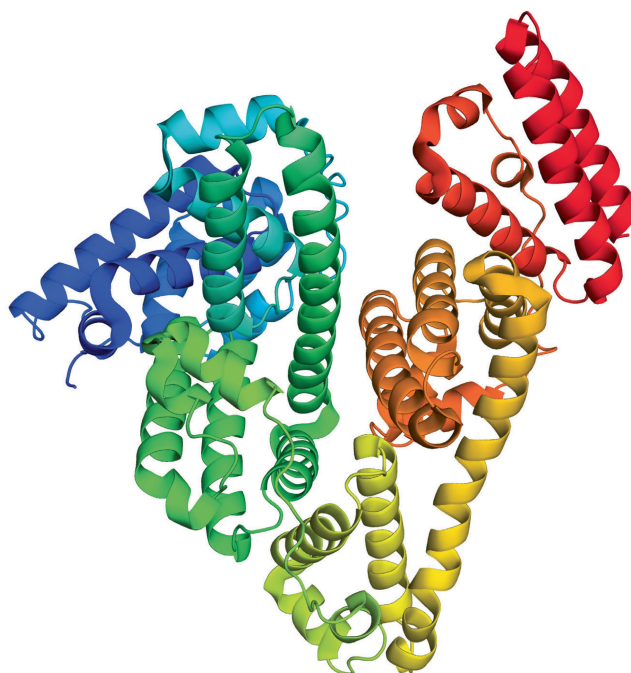


FIGURE 154 Ribbon model of the three-dimensional structure of Bos d 6 (PDB code: 3V03). N-terminal end in blue, C-terminal end in red.

regulation of colloid osmotic pressure. Serum albumins transport a multitude of metabolites, nutrients, drugs, and other molecules.⁴⁶⁹ They have an α -helical structure with three domains stabilized by several disulfide bridges. Serum albumins change their conformation in order to bind diverse ligands. These proteins present in dander, saliva, milk, and meat are thermolabile and easily denatured in food by cooking. Chicken serum albumin, formerly known as α -livetin, is an allergen of egg yolk. Seven serum albumin allergens are officially recognized by the IUIS Allergen Nomenclature Subcommittee: Bos d 6 (bovine), Can f 3 (dog), Cav p 4 (guinea pig), Equ c 3 (horse), Fel

d 2 (cat), Gal d 5 (chicken), and Sus s 1 (pig) (Table 83). However, a number of serum albumins from different animals have been shown to bind IgE and to be cross-reactive: sheep, goat, rabbit, hamster, mouse, rat, and other mammals, as well as birds like pigeon, although these serum albumins are not yet categorized as allergens.¹⁶⁶⁸

Serum albumins have a molecular weight of 65-69 kDa. They are composed of 607-608 amino acids and the signal peptide and a pro-peptide of 18 and four amino acids respectively are cleaved off during maturation. Mammalian serum albumins have highly conserved amino acid sequences¹⁴⁶⁷ and show sequence identities of 72-82% with human serum albumin (HSA). Avian serum albumins display lower identities (46-49%) with HSA and other mammalian serum albumins (42-48%).

Table 84 displays two-by-two comparisons of amino acid identities between HSA and different serum albumins. The identity between HSA and mammalian serum albumins is very high. It was generally assumed that proteins with a sequence identity to a human homologue above 62% were rarely allergenic.¹⁴⁶⁸ Serum albumins constitute a remarkable exception to this rule. Other important animal allergen families such as tropomyosins, β -parvalbumins, and caseins lie below this threshold. IgE-cross-reactivity between mammalian serum albumins has been well documented.¹⁶⁶⁷ All pairs with a high sequence identity (>70%) are potentially cross-reactive. It has been postulated that below 50%, cross-reactivity is rare.^{13,1528} Cross-reactivity between mammalian and the less-conserved avian serum albumins seems to be rare, but it has been documented in single case reports.¹⁶⁷⁰ Molecules displaying a low level of overall sequence identity may nevertheless share single epitopes composed of

short stretches of sequence identity that lead to patient-dependent IgE-cross-reactivity.

A comparison of the surfaces of some important allergenic mammalian serum albumins visualizes potential cross-reactive B cell epitopes (Figure 155). B- and T-cell recognizing HSA epitopes will be deleted during the immunological education process. Figure 156 illustrates cross-reactivity among some important serum albumins recognized by the IUIS.

3 – Clinical relevance

Serum albumins are respiratory allergens present in animal dander and fluids such as milk, serum, urine, and saliva. They are considered minor allergens.⁴⁷⁷ Depending on the study population, approximately 14-50% of cat and dog-allergic patients present IgE to cat or dog albumins. Monosensitization to cat or dog serum albumin seems to be extremely rare in a primary sensitization. IgE to Fel d 2 is usually detected along with IgE directed to a major allergen (such as Fel d 1). On the contrary, the presence of IgE to Can f 3 without any detectable IgE to other dog allergens (Can f 1 or Can f 2) is thought to be a marker of cross-reactivity and the primary sensitization source should be sought after. The clinical relevance of IgE to serum albumins concerning respiratory symptoms, is difficult to explore as IgE to other allergens from the same animal are always present in the same patient. It is generally assumed that they are of low relevance. However, two cases of occupational asthma triggered by inhalation of Bos d 6 have been reported in laboratory workers.^{1378,1668} High

TABLE 83 Bos d 6-homologous allergens from animals

Animal family	Allergen source	Allergen
Bovidae	Domestic cattle (<i>Bos domesticus</i>)	Bos d 6
Canidae	Dog (<i>Canis familiaris</i>)	Can f 3
Cavidae	Guinea pig (<i>Cavia porcellus</i>)	Cav p 4
Equidae	Domestic horse (<i>Equus caballus</i>)	Equ c 1
Felidae	Cat (<i>Felis domesticus</i>)	Fel d 2
Phasianidae	Chicken (<i>Gallus domesticus</i>)	Gal d 5
Suidae	Domestic pig (<i>Sus scrofa</i>)	Sus s 1

TABLE 84 Amino acid identities (%) between allergenic serum albumins and HSA¹⁴⁶⁷. Dark blue shaded areas indicate sequence identities >80%, light shaded areas display identities between 71 and 80%. Figures in bold blue indicate documented IgE-cross-reactivity between albumins. HSA, human serum albumin.

Bos d 6									
Can f 3	76								
Cav p 4	70	73							
Equ c 3	74	76	72						
Fel d 2	78	87	76	78					
Gal d 5	43	46	43	43	45				
HSA	76	80	72	76	82	46			
Sus s 1	79	78	72	76	79	42	75		
	Bos d 6	Can f 3	Cav p 4	Equ c 3	Fel d 2	Gal d 5	HSA	Sus s 1	

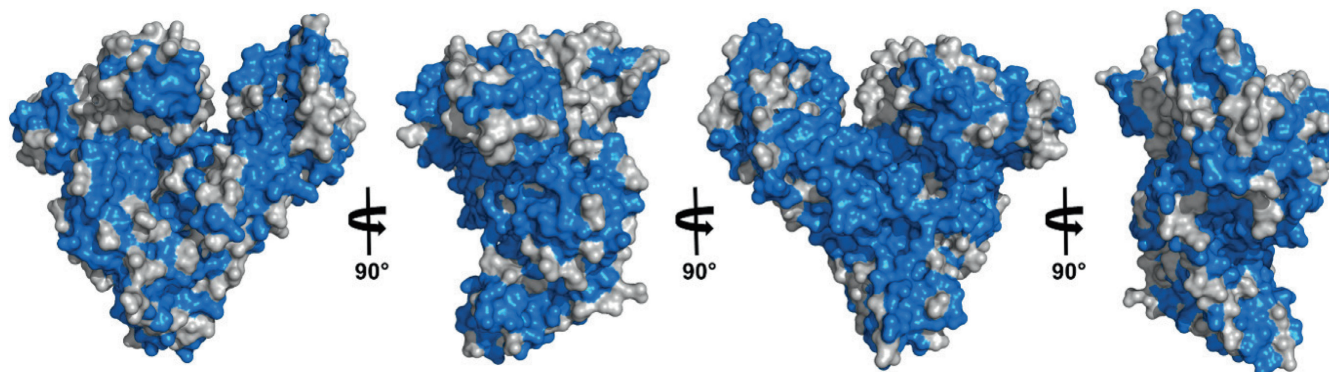


FIGURE 155 Surface representation of BSA molecule (PDB code: 3V03) shown in four side views. Residues that are identical in bovine (*Bos d 6*), feline (*Fel d 2*), and porcine (*Sus s 1*) albumins are colored in blue. The identical residues form large surface patches that can be recognized by cross-reactive antibodies. Residues that are different between *Bos d 6*, *Fel d 2*, and *Sus s 1* are marked in grey.

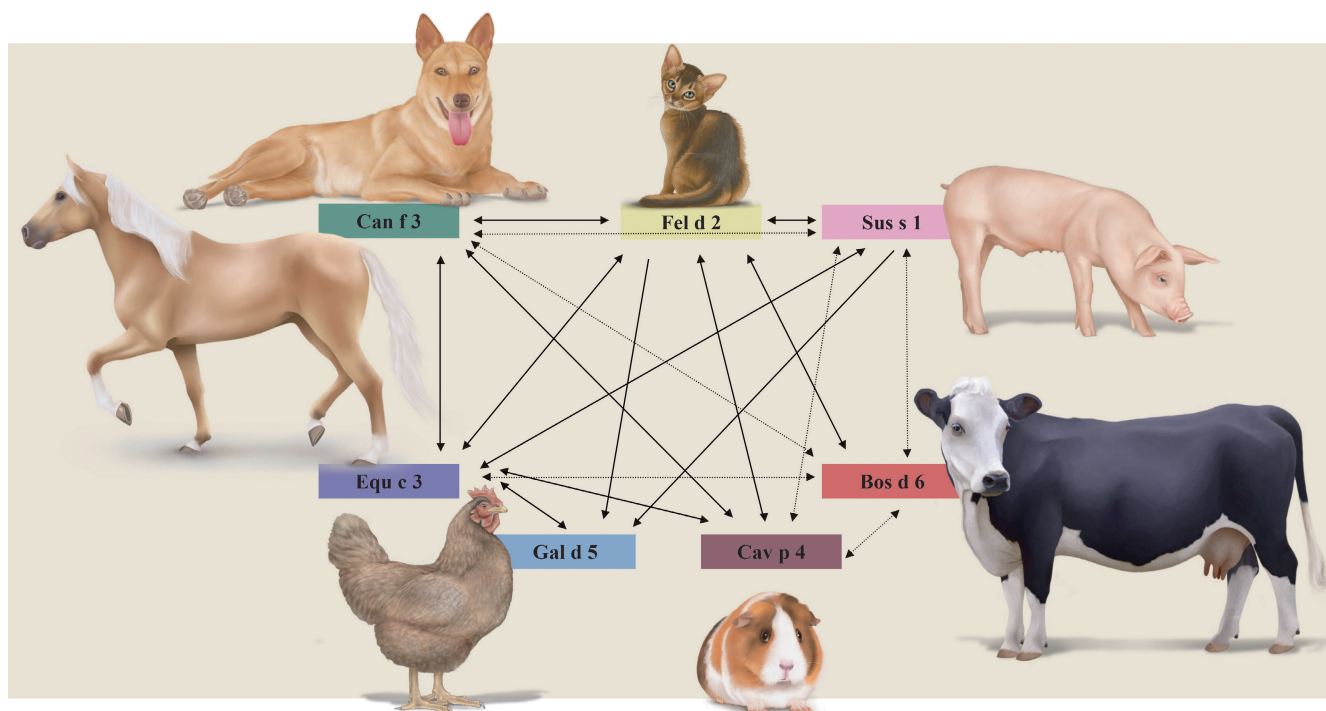


FIGURE 156 Cross-reactivities among allergenic serum albumins. All mammalian serum albumins are potentially IgE-cross-reactive. Clinical cross-reactivity between mammalian *Fel d 2* and *Sus s 1* and avian *Gal d 5* are rare and have been documented only from mammal to bird. Solid lines represent documented IgE-cross-reactivity, and dashed lines show hypothetical cross-reactivity.

levels of IgE antibodies to *Fel d 2* have been associated with atopic dermatitis in cat-allergic children.⁸⁰⁹

In contrast to its role as a respiratory allergen, serum albumin in food has been shown to elicit minor, moderate, and severe clinical symptoms. *Bos d 6* is a component of the milk whey fraction and constitutes about 1% of the total protein content of milk (0.1–0.4 g/L). In a series of 60 children with immediate reactions to milk confirmed by DBPCFC, 61.3% had allergen-specific IgE antibodies to *Bos d 6*.⁹⁵³ Boiling milk for 10 minutes eliminated skin prick test

responses in subjects reactive to BSA. Cross-reactivity has been described between different mammalian milks. *Bos d 6*, and the major bovine milk allergens casein and β -lactoglobulin have homologues in milk from other species. Serum albumins are also an important allergen in meat. A high percentage of milk-allergic children (13–20%) are also allergic to beef.^{953,974} In a series of 28 children diagnosed with beef allergy, 92.9% were diagnosed as allergic to milk by skin prick test and DBPCFC. In children with beef allergy, sensitization to *Bos d 6* is a marker of cow's milk allergy.^{953,974} Because

Bos d 6 is a thermolabile allergen, well-done meat is tolerated by most patients.

Albumins are also involved in cross-reactivity between animal dander and milk or meat. A patient allergic to horse developed a systemic reaction upon ingestion of mare's milk.¹⁴⁷¹ The association between allergy to cat dander and pork meat, known as pork-cat syndrome, was described more than a decade ago in Europe.¹⁴⁷⁰ Among two groups of cat-allergic patients, 14 and 23% had specific IgE to Fel d 2 and 3-10% had cross-reacting IgE to porcine albumin.⁷⁹⁵ Among those, one of three experienced clinical symptoms upon ingestion of pork meat. Thus, 1-3% of cat-allergic patients could develop pork-cat syndrome. This syndrome has also been described in the United States and should be differentiated from the delayed meat allergy based on IgE to alpha-gal (see chapter B14).¹⁰⁹³ Although pork-cat syndrome represents the most frequent clinical cross-reactivity between mammalian dander and meat, additional isolated cases have been described, such as between horse meat and animal dander or between pork and horse dander.¹⁴⁷¹ However, pork-cat syndrome may not be limited to food, as shown by a case of occupational asthma triggered by handling of cured meat.¹⁴⁷²

Chicken serum albumin (Gal d 5) is an inhalant and food allergen implicated in the bird-egg syndrome¹⁴⁷³ or egg-bird syndrome, depending on the primary exposure.¹⁶⁷⁰ It is present in egg yolk and it has also been detected in domestic air samples. Bronchial challenges elicited asthmatic responses in six asthmatic patients. IgE reactivity was reduced to 88% after heating at 90°C for 30 minutes. Chicken serum albumin Gal d 5 does not share any sequence identity with ovalbumin Gal d 2, a storage protein and allergen from egg white.

The wide use of BSA in cell culture media holds new risks. Several case reports have shown that Bos d 6, an ingredient of the culture medium of spermatozooids, has provoked severe anaphylactic reactions upon artificial insemination.⁴⁷⁷ Presence of BSA in media during the production of vaccines is another potential risk factor. Therefore, WHO has set a guideline stating that no more than 50 ng of BSA can be present in a single vaccine dose, likely lowering the number of reactions to BSA in vaccines.¹⁴⁷⁴ However, some cases of allergic reactions to vaccines are most likely associated with continued presence of BSA.¹⁴⁷⁵ Recently, BioGlue, a surgical adhesive composed of BSA, has been implicated in two cases of perioperative anaphylaxis in patients allergic to cat and sensitized to Fel d 2.^{1476,1477} The high concentration of BSA and a brief exposure of cross-reactive epitopes before complete denaturation and strong protein cross-linking may contribute to the severity of the reaction.

Allergy to HSA is very rare even in cases when recombinant protein is used.¹⁴⁷⁸ However, recently there were two reports indicating that HSA is responsible for anaphylactic reactions.^{1479,1480} In one of these cases, the authors speculated that reaction to HSA may be associated with the presence of small molecular compounds that are used to prevent aggregation of commercial formulations of HSA or used during sterilization, or that are present in tubing used

to administer the albumin solution.¹⁴⁸⁰ Other studies suggested that modification of HSA by isocyanates, which are used in production of polyurethane, may lead to formation of new antigens that can cause asthma.^{1481,1482}

Clinical relevance

- Minor respiratory allergen from animal dander
- Mean sensitization rates of up to 30% in patients allergic to furry animals
- Allergen implicated in pork-cat syndrome
- Meat and milk allergen
- May elicit severe symptoms upon ingestion of uncooked or boiled food
- Allergen implicated in bird-egg syndrome No molecule-based therapeutic approach available

As serum albumins are minor allergens, there is no current research on the development of hypoallergenic molecules. Current immunotherapies available contain animal dander extracts and may vary in albumin content.

4 – Clinical management

A careful record of the clinical history such as the presence of pets at home or regular pet contact is of great value. Skin prick test or allergen-specific IgE using animal dander will confirm animal sensitization. In order to define the primary sensitization source, specific IgE to major allergens such as Fel d 1, Can f 1, Can f 2, or Can f 5 should be determined (see chapter B06). The number of available components is increasing and hopefully more allergens including those of small furry pets will be available on all commercial platforms. IgE antibodies directed to serum albumins are a marker of cross-reactivity but do not mandatorily imply clinical cross-reactivity. Patients with IgE to serum albumins should be advised to avoid mammalian pets as they may experience clinical symptoms upon contact with any pet. As mammalian serum albumins are highly cross-reactive, the choice of serum albumins included in the determination of allergen-specific IgE should be guided by clinical history (Figures 157–159). Specific IgE are mostly positive to Can f 3 and Fel d 2, whereas IgE reactivity against Bos d 6 and Sus s 1 are less frequent. Gal d 5 should be considered as an independent allergen, as homology to mammalian albumins is very low. Patients with moderate to high levels of IgE to serum albumins are at risk to develop symptoms upon ingestion of raw milk and raw or medium cooked meat such as sausages, ham, and steaks. Levels of IgE to Bos d 6 and Sus s 1 should be determined and patients should be carefully advised. As serum albumins

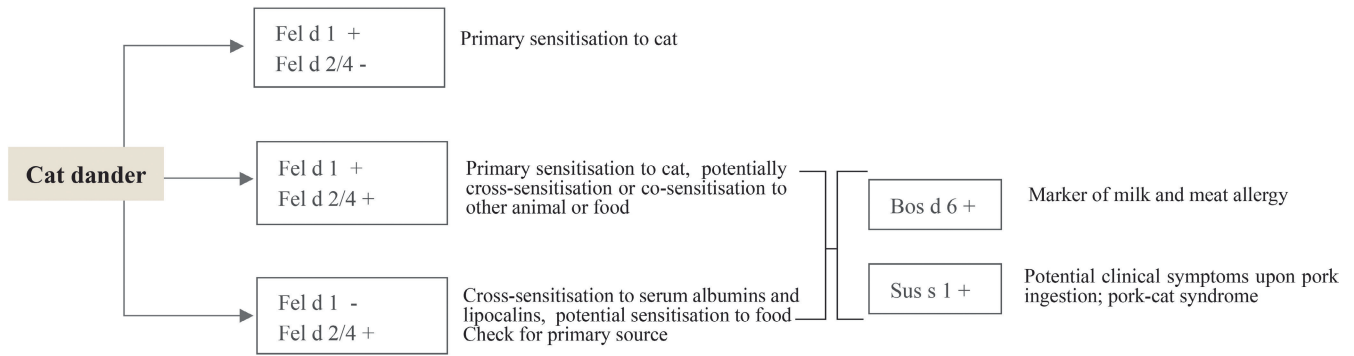


FIGURE 157 Added value of the use of single allergens in the case of a positive IgE test to cat dander

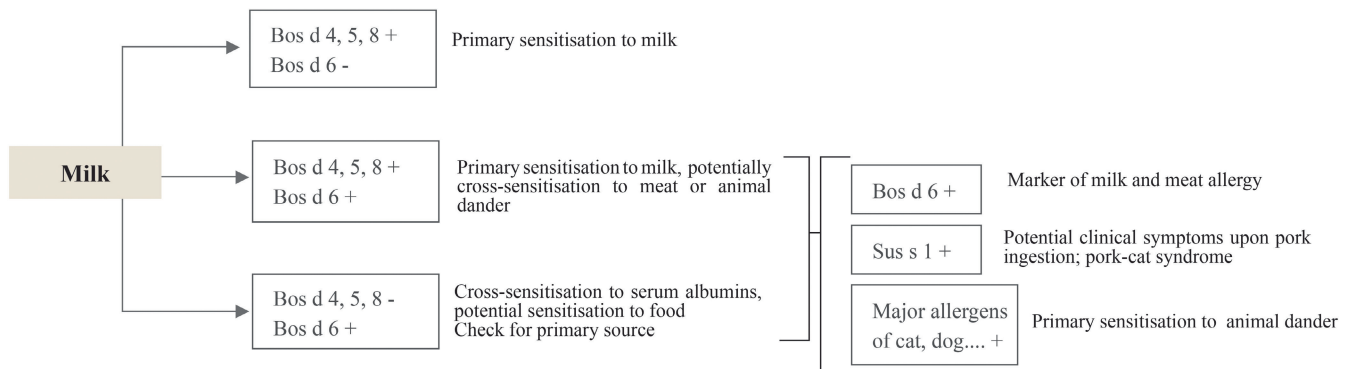


FIGURE 158 Added value of the use of single allergens in the case of a positive IgE test to milk

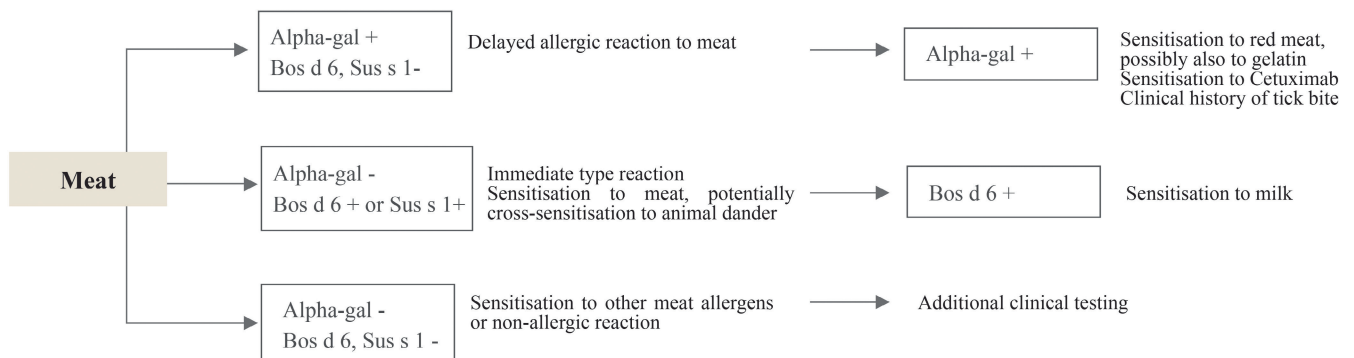


FIGURE 159 Added value of the use of single allergens in the case of a positive IgE test to meat

are thermolabile, well-cooked meat and pasteurized or boiled milk may be tolerated.

5 – Clinical cases

Case 1 (published⁷⁹⁵)

Clinical history: A 17-year-old girl with a history of rhinitis and asthma when exposed to cat experienced anaphylactic reactions on two occasions after ingestion of pork ham or sausage.

Tests with extracts: The patient had positive skin prick tests to cat dander and pork. Specific IgE were positive for cat dander (>100 kU/L) and pork (22 kU/L).

Tests with molecules: Specific IgE was positive to several animal serum albumins Fel d 2: (165 kU/L), Can f 3: (37 kU/L), Sus s 1 (22 kU/L) and Bos d 6 (2.5 kU/L). IgE to Sus s 1 could be totally inhibited by prior incubation of the patient's serum with Fel d 2, confirming a primary sensitization to cat.

Conclusion: Results were consistent with pork-cat syndrome and the patient was advised to avoid eating pork.

Case 2 (original)

Clinical history: For one year, a 27-year-old male patient suffered from labial edema after ingestion of vanilla ice creams and from cough during the night after ingestion of cow's milk (1 bowl) before bedtime.

Four months ago, an anaphylaxis (generalized urticaria, palpebral edema, dyspnea) occurred after ingestion of a food supplement (100% Whey Ultra) containing a whey protein concentrate.

The reaction started during the morning one hour after ingestion of the food supplement and beginning physical exercise (bodybuilding). He had not ingested anything else since the evening before.

He suffered from asthma since childhood with cat and dust mite allergy. For the last 6 months, due to unemployment, he has been living again with his mother who has a dog.

Tests with extracts: Positive aeroallergenic skin prick tests (mm): house dust mites 10, cat 10.5, dog 6, guinea pig 6, rabbit 5, hamster 4, grass pollens 6. Prick-to-prick tests (mm): cow's milk 5, goat's milk 8.5, raw pork 12, cooked pork 0, raw lamb 9.5, cooked lamb 2, raw beef 3, cooked beef 1; negative for raw chicken and egg. Specific IgE to cow's milk: 0.45 kU/L

Tests with molecules: Specific IgE: Bos d 6: 0.80 kU/L; IgE to casein, beta-lactoglobulin, α -lactalbumin and alpha-gal <0.1 kU/L
IgE Can f 1: 8.66 kU/L, Can f 2: 0.48 kU/L, Can f 3: 34 kU/L
IgE Fel d 1: 5.09 kU/L, Fel d 2: 17 kU/L

Conclusion: Results are consistent with a primary sensitization to dog and/or cat and an allergy to milk, triggered by cross-reactivity

between cat and dog serum albumins and cattle serum albumin, present in dairy products.

Case 3 (published¹⁴⁷¹)

Clinical history: A 38-year-old woman was referred for asthma exacerbation. Upon dog contact, she first experienced oropharyngeal pruritus and rhinitis with sneezing and nasal obstruction, and more recently, cough and wheezing. She reports a previous anaphylactic reaction upon ingestion of horse meat and oropharyngeal pruritus after ingestion of ham.

Tests with extracts: Skin prick tests were positive for cat and dog dander as well as for horse meat, pork, and beef (prick-to-prick with raw meat). Allergen-specific IgE were positive for dog dander (67 kU/L), horse dander (0.58 kU/L), and pork (1.61).

Tests with molecules: The patient had specific IgE to Can f 1 (2.04 kU/L), Can f 3 (37 kU/L), and Fel d 2 (14.3 kU/L). Specific IgE were negative for alpha-gal, Fel d 1, Can f 2, and Equ c 1. The presence of sIgE directed at Equ c 3 was detected by ELISA. Inhibition experiments confirmed a primary sensitization to Can f 3 and an IgE-cross-reactivity to Equ c 3.

Conclusion: Results were consistent with anaphylaxis to horse meat induced by exposure to dog dander and cross-reactivity between dog and horse albumin.

Allergen nomenclature: Fel d 2, Bos d 6, Can f 3, Sus s 1, Equ c 3, Gal d 5: cat, bovine, dog, porcine, horse and chicken serum albumins respectively.

C05 – Tropomyosins

Luis Caraballo, Andreas L. Lopata, Nathalie Acevedo

Highlights

- Thermostable protein, high allergenicity
- Considered an invertebrate pan-allergen
- High degree of immunological and clinical cross-reactivity
- Seafood allergy, mostly induced by tropomyosins, is frequent in several populations
- Mite and *Ascaris* tropomyosin sensitization may affect asthma symptoms

1 – The protein

The shrimp (*Penaeus aztecus*) major allergen, Pen a 1, is one of the most clinically relevant allergenic tropomyosins.^{1483–1485} Its basic characteristics are presented in Table 85.

There is no three-dimensional structure available from any allergenic tropomyosin. Still, the predicted models of representative tropomyosins from shrimp, house dust mite and the nematode *Ascaris* are presented in (Figure 160) The secondary structure is a coiled-coil molecule formed by two parallel alpha-helices.

TABLE 85 Protein characteristics of Pen a 1

Protein characteristics of Pen a 1	
Allergen source	Shrimp
Protein family	Tropomyosin
UniProtKB accession	Q3Y8M6
Crystal structure	No
Molecular structure	Alpha-helical
Theoretical molecular weight	32.8 kDa
Length	284 amino acids
Ligand binding	Yes
Dimerization	Homodimer
Glycosylation	No
Disulfide bonds	No
Isoelectric point	4.72
Synthesis	Several isoforms
Distribution	Muscle and non-muscle cells

Together with actin and myosin, tropomyosin plays an important role in the muscle contractile activity, and the regulation of cell morphology and motility. Tropomyosins are heat-stable, which partially explains their high allergenic activity; in addition, structural stability,¹⁴⁸⁶ endolysosomal degradation and subsequent peptide generation explain differences between cellular and humoral responses to some tropomyosins.¹⁰⁵⁷ Shellfish allergenic tropomyosins were first described in shellfish and shrimp,^{1487–1489} but they are important allergens in other sources like house dust mites (HDM) and cockroaches. See also chapters B13 for shellfish/HDM cross-reactivity and B09 for insect cross-reactivity. The relevance of sensitization to tropomyosins varies from low clinical impact to anaphylaxis. In addition, tropomyosin has been found to bind epithelially expressed dectin-1, which suppresses the development of type 2 immune responses through inhibition of the production of IL-33 by bronchial epithelial cells and the subsequent recruitment of IL-13-producing innate lymphoid cells in mice, which in turn regulates dust mite sensitization. This process is genetically controlled since variants of the dectin-1 gene have different levels of expression in the epithelium.⁷³⁰

Several IgE-binding epitopes of shrimp tropomyosins have been reported. Ayuso et al. identified five major IgE-binding regions on Pen a 1 cross-reactive epitopes among shrimp, lobster, house dust mite and cockroach.^{1490,1678} The sites include eight IgE-binding epitopes: epitope 1 (residues 43 – 55) in region 1; epitope 2 (residues 87 – 101) in region 2; epitopes 3a (residues 137 – 141) and 3b (residues 144 – 151) in region 3; epitope 4 (residues 187 – 197) in region 4; and epitopes 5a (residues 249 – 259), 5b (residues 266 – 273), and 5c (residues 273 – 281) in region 5. The sequence identity of these regions to homologous regions of other tropomyosins varies from 56% (rabbit) to 98% (lobster).

Further analyses of these epitopes and comparing them with other related sequences suggested that they can be classified into three types: epitope 5a that is highly conserved among crustaceans, mollusks, insects and mites. The second type comprised epitopes 2, 3 and 4, that represent all arthropods but not mollusks. The third type includes epitopes 1, 5b, and 5c, specific to crustaceans.¹⁴⁹¹ Epitope mapping of other tropomyosins such as Pen j 1, Pen m 1 and Pan b 1 from shrimp, Tur c 1 (snail), Cra g 1 (oyster) and Oct v 1 (octopus) have also been performed. Overall, the C terminal region is the most conserved among invertebrate tropomyosins.⁷⁷³ The high immunological cross-reactivity among crustacean tropomyosin is probably because 91% of IgE epitopes are conserved, as compared to mites (48%). By contrast, mollusks IgE is epitope-region less than 20% conserved, reflected in low clinical cross-reactivity between

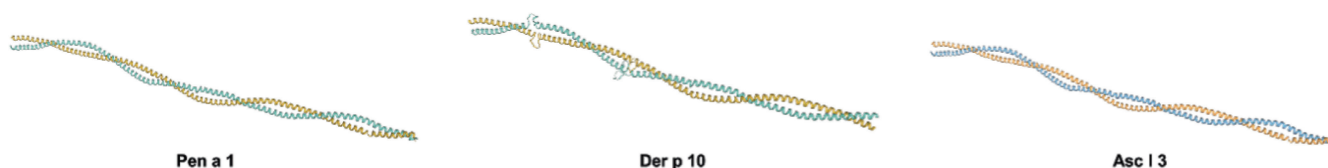


FIGURE 160 Molecular models of tropomyosins from shrimp (Pen a 1), house dust mite (Der p 10), and the nematode *Ascaris lumbricoides*, Asc l 3.

TABLE 86 A list of clinically relevant tropomyosins

Family	Allergen source	Allergen
Penaeoidea	Brown shrimp (<i>Penaeus aztecus</i>)	Pen a 1
	Northern Red Shrimp (<i>Pandalus borealis</i>)	Pan b 1
	Giant tiger prawn (<i>Penaeus monodon</i>)	Pen m 1
	European Shrimp (<i>Litopenaeus vannamei</i>)	Lit v 1
	Common Shrimp (<i>Crangon Crangon</i>)	Cra c 1
Palinuridae	Spiny lobster (<i>Panulirus stimpsoni</i>)	Pan s 1
Cancridae	Common crab (<i>Charybdis feriatus</i>)	Cha f 1
	Blue swimmer crab (<i>Portunus pelagicus</i>)	Por p 1
Hellixidae	Brown garden snail (<i>Helix aspersa</i>)	Hel as 1
Mytilidae	Green mussel (<i>Perna viridis</i>)	Per v 1
Octopodidae	Common Octopus (<i>Octopus vulgaris</i>)	Oct v 1
Ommastephidae	Japanese flying squid (<i>Todarodes pacificus</i>)	Tod p 1
Osteidae	Pacific cupped oyster (<i>Crassostrea gigas</i>)	Cra g 1
Haliotidea	Abalone (<i>Haliotis diversicolor</i>)	Hal d 1
Pyroglyphidae	House dust mite (<i>Dermatophagoides farinae</i>)	Der f 10
	House dust mite (<i>D. pteronyssinus</i>)	Der p 10
Echymipodidae	Storage mite (<i>Blomia tropicalis</i>)	Blo t 10
Blattidae	American cockroach (<i>Periplaneta americana</i>)	Per a 7
Blattellidae	German cockroach (<i>Blattella germanica</i>)	Bla g 7
Anisakidae	Anisakis (<i>Anisakis simplex</i>)	Ani s 3
Ascaridae	Roundworm (<i>Ascaris lumbricoides</i>)	Asc l 3

crustacean and mollusks. Specific epitopes in the N- and C-terminal region of tropomyosins seem to distinguish between crustacean only and specific crustacean-mollusk cross-reactivity.¹⁰⁸²

In addition, T cell epitopes have been described. Ravkov E et al., using an *in vitro* MHC-peptide binding assay and *ex vivo* proliferation and cytokine release assays, identified and validated 17 T cell epitopes restricted to multiple MHC class II alleles. This finding is potentially useful for designing peptide-based immunotherapy of shrimp allergy. The challenge of further studies is to analyze which tropomyosins epitopes are species-specific markers. For example, common and specific epitopes have been reported among tropomyosins from two important HDM.¹⁴⁹²

2 – The family

Tropomyosin belongs to a family of proteins (Pfam PF00261) that includes a large number of cross-reactive allergens, most of them from invertebrate sources, such as shrimp, lobster, crab, snail, abalone, whelk, clam, mussels, octopus, house dust mites, cockroaches and helminths (Tables 86 and 87).

Vertebrate tropomyosins have been regarded as nonallergenic, but IgE sensitization to fish tropomyosin¹⁰¹⁰ as well as cross-reactivity between shellfish and fish tropomyosin has been detected.¹⁰¹⁶

A great number of IgE-binding tropomyosins have been described, some of them cloned and expressed as recombinant proteins and tested for allergenicity. However, only few (Pen a 1, Pen m

1, Ani s 3, Bla g 7 and Der p 10) have been included in commercial *in vitro* allergy testing. Tropomyosin amino acid sequence is highly conserved among shellfish and other invertebrates, they share over 70% identity; their comparison with vertebrate tropomyosins reveals 51 to 57% identity.^{1015,1483}

Leung P et al. have shown that serum IgE to shrimp also binds tropomyosin of other shellfish such as greasy back shrimp, spiny lobster, Indo-Pacific swamp crab, abalone, whelk, green mussel, pen shell, scallop, Pacific oyster, cuttlefish, sword tip squid and octopus,¹⁴⁹⁴ which reflects the high cross-reactivity of this family. Still, tropomyosins are not the only shellfish allergens; other cross-reactive clinically relevant allergens have been reported,¹⁴⁹¹ also see Chapter B13.

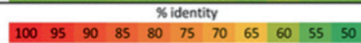
To compare the protein sequences of allergenic tropomyosins, Leung M et al.¹⁴⁹¹ conducted a phylogenetic analysis. They found that arthropods tropomyosins share 91.7% homology (76.1 - 100%) and mollusks share 77.2% (65.1 - 99.3%), which indicates that, at the whole sequence level, tropomyosins are not species-specific allergy markers.

All tropomyosin pair with a sequence alignment of over 80% could be considered as high and are potentially cross-reactive. Sequence alignments are good primary prediction tools for cross-reactivity, but most importantly, the use of IgE-inhibition studies with sera from clinically well-characterized patients will allow defining clinically relevant cross-reactivity (Figure 161). In fact, the combination of experimental data with bioinformatic tools has been useful for predicting diagnosis-associated tropomyosins cross-reactive epitopes.¹⁰⁸²

A comprehensive phylogenetic tree of allergenic tropomyosins from various taxonomic groups is shown in (Figure 162).

TABLE 87 Amino acids identities between some tropomyosins

Classification	Species	Accession number	#	Crustacean											Insect		Mite		Mollusc										Fish	Human
				1	2	3	4	5	6	7	8	9	10	11	12	13	14	15	16	17	18	19	20	21	22	23	24	25	26	27
Crustacean	Giant tiger prawn	A1KY22	1	100																										
	Brown shrimp	Q3Y8M6	2	100	100																									
	Whiteleg shrimp	B4YAH6	3	100	100	100																								
	Giant fresh water prawn	D3XNR9	4	98	98	98	100																							
	Blue swimmer crab	M1H607	5	98	98	98	97	100																						
	Mud crab	A7LSV2	6	93	93	93	92	92	100																					
	Snow crab	A2V735	7	89	89	89	89	88	95	100																				
	Common yabby crayfish	W5RFX0	8	98	98	98	98	99	93	89	100																			
	South African spiny lobster	K9UTQ8	9	94	94	94	94	94	96	92	94	100																		
	Red rock lobster	W5RFX7	10	95	95	95	95	92	88	95	93	100																		
	Flathead lobster	W5RFZ5	11	98	98	98	97	100	92	88	99	94	95	100																
Insect	American cockroach	Q9UB83	12	82	82	82	82	81	83	80	82	83	81	82	100															
	German cockroach	Q9NG56	13	82	82	82	82	83	80	83	84	82	82	97	100															
Mite	European house dust mite	O18416	14	80	80	80	80	80	82	78	80	82	79	80	80	100														
	American house dust mite	Q23939	15	82	82	82	82	81	83	80	82	84	81	81	81	98	100													
Mollusc	Bay scallop	A1KY24	16	56	56	56	57	56	57	56	57	58	58	56	56	55	58	60	100											
	Japanese scallop	Q9GUW9	17	60	60	60	61	60	61	60	60	62	61	60	59	58	60	62	88	100										
	Blue mussel	Q25457	18	57	57	57	57	56	57	56	57	58	58	57	57	55	57	71	71	100										
	Pacific oyster	B7XC66	19	62	62	62	62	61	62	60	62	63	62	62	61	60	60	62	74	75	79	100								
	Common octopus	Q2V0V0	20	64	64	64	64	63	64	63	64	65	64	64	62	62	63	65	71	74	71	76	100							
	Japanese flying squid	Q2V0V2	21	63	63	63	63	63	63	61	63	63	64	63	61	60	63	64	70	71	70	75	91	100						
	Golden cuttlefish	Q2V0V4	22	63	63	63	64	63	64	63	64	64	64	64	62	61	64	65	71	73	71	76	92	98	100					
	Brown garden snail	O97192	23	64	64	64	64	64	63	62	64	64	64	64	63	62	64	65	73	76	70	76	83	82	84	100				
	Horned turban	B7XC63	24	62	62	62	63	62	62	60	62	63	63	62	61	60	62	64	71	76	74	78	81	80	81	87	100			
	Disc abalone	B7XC62	25	63	63	63	64	63	63	61	63	64	64	63	62	63	64	71	77	75	79	83	81	81	87	97	100			
	Fish	Mozambique tilapia	K4PEK4	26	57	57	57	58	57	58	58	57	60	58	57	54	54	58	52	54	52	55	56	55	55	55	55	100		
Human		P06753	27	57	57	57	58	57	58	58	57	59	57	57	54	55	58	58	51	53	52	55	55	54	54	56	55	55	94	100



Tropomyosins belonging to the Group 10 allergens of HDM and Group 7 allergens from cockroach cross-react with shrimp tropomyosins and have also been described as clinically relevant allergens. For example, cross-reactivity between purified tropomyosins from mosquito and HDM has been reported recently.¹⁴⁹⁴ In addition, tropomyosins from edible insects, whose consume is increasing in Western countries, can be an important source of cross-reactivity with other tropomyosins, including those from HDM, cockroach and crustaceans.^{1495,1496}

The allergenic activity and cross-reactivity of *Ascaris lumbricoides* (an intestinal helminth) tropomyosin (Asc I 3) has been thoroughly analyzed^{773,1497,1498}; further studies have shown an important clinical impact by sensitizing the asthmatic populations in underdeveloped tropical countries,^{1499,1500} where helminthiasis, together with perennial exposition to mite tropomyosins might increase asthma symptoms and predispose to allergic reactions to shrimp.^{775,1501,1502}

Cross-reactivity between HDM allergens and some shellfish has been described and reports suggest that it is clinically significant.¹⁵⁰³ Subcutaneous HDM immunotherapy in patients sensitized to shrimp or snail could increase allergy symptoms after ingestion of these foods. Previous studies demonstrated IgE binding to shrimp tropomyosin in Orthodox Jews, which are prohibited to consume shellfish, most probably due to their house dust mite allergy.¹⁵⁰⁴ Although cross-reactive tropomyosins are good candidates for explaining these observations, other allergens may be involved. In addition, other authors have obtained opposite results after immunotherapy, suggesting that the adverse side effects are not general and could be influenced by the type of immunotherapy and genetic factors determining the susceptibility to get sensitized by other allergens. Therefore, more research is needed to define

this controversial effect of cross-reactivity among arthropods on immunotherapy.

3 - Clinical relevance

Tropomyosins from invertebrates are allergenic for genetically susceptible individuals and due to their extensive cross-reactivity, are considered pan-allergens. Recently the vertebrate tropomyosin, Ore m 4, was described as a major allergen of tilapia (*Oreochromis mossambicus*)¹⁵⁰⁵ and has subsequently been shown to be a major IgE-binding allergen in salmon and catfish in over 30% of fish allergic children.¹⁰¹⁰ Sensitization can occur by ingestion (seafood), inhalation (mites, cockroaches) or parasite infection (ascariasis, anisakiasis) including parasite-infested food sources such as raw fish, e.g., in food sources such as sushi or ceviche (PMID: 26252073, PMID: 29588070). See also Chapter B12. It has been hypothesized that primary inhalant sensitization to HDM tropomyosins might be followed by sensitization to shellfish in regions where HDM exposure is predominant.¹⁰⁸¹ However, when the primary sensitizer is a tropomyosin from an inhaled source (Der p 10, Blo t 10 or Bla g 7) the tolerance to crustaceans, mollusks and cephalopods is higher than when Pen a 1 is the primary sensitizer. It remains to be determined how the clinical manifestations can differ depending on the tropomyosin that acts as the primary sensitizer.

Most allergenic tropomyosins are major shellfish allergens. Symptoms may be induced by very low amounts of the offending food and sometimes by inhalation. They include immediate cutaneous reactions (urticaria, angioedema, rash) oral allergy syndrome (swelling in the lips and mouth), digestive symptoms (vomiting, abdominal cramping, and diarrhea), anaphylaxis and asthma.

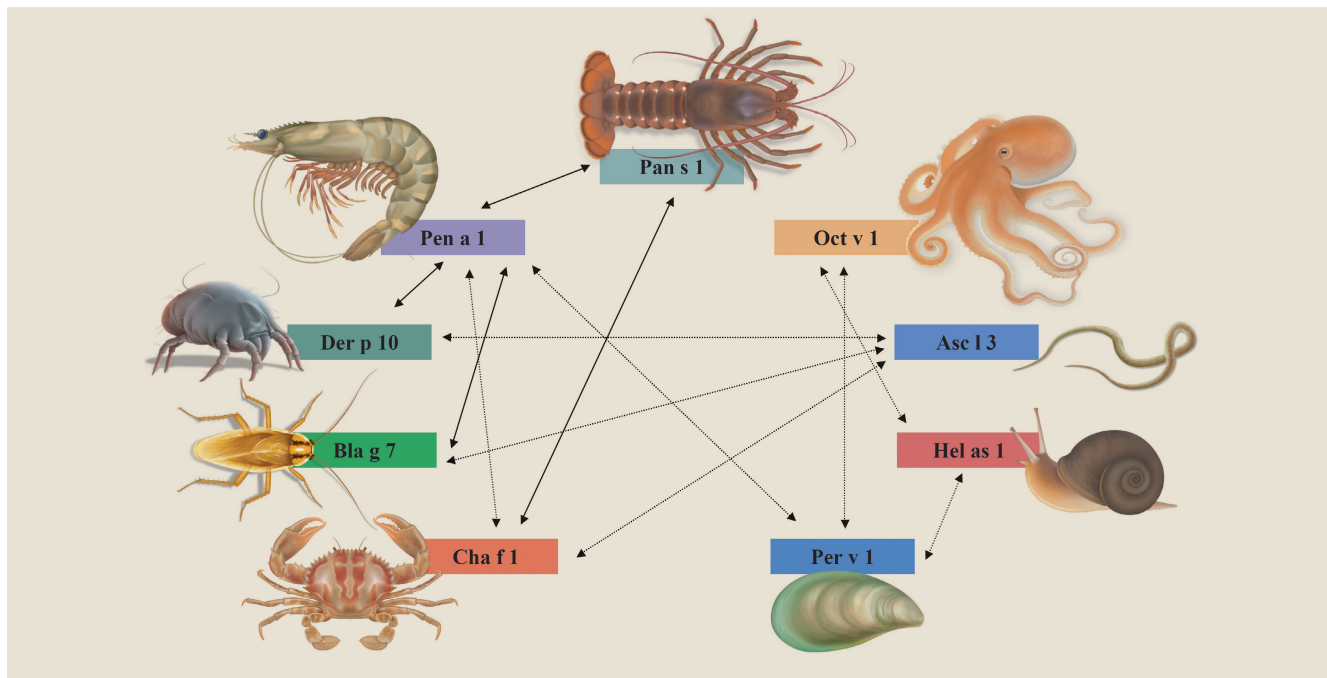


FIGURE 161 Cross-reactivity among allergenic tropomyosins from several sources. Lines represent documented IgE-cross-reactivity, dotted lines represent potential IgE cross-reactivity based on high sequence identities.

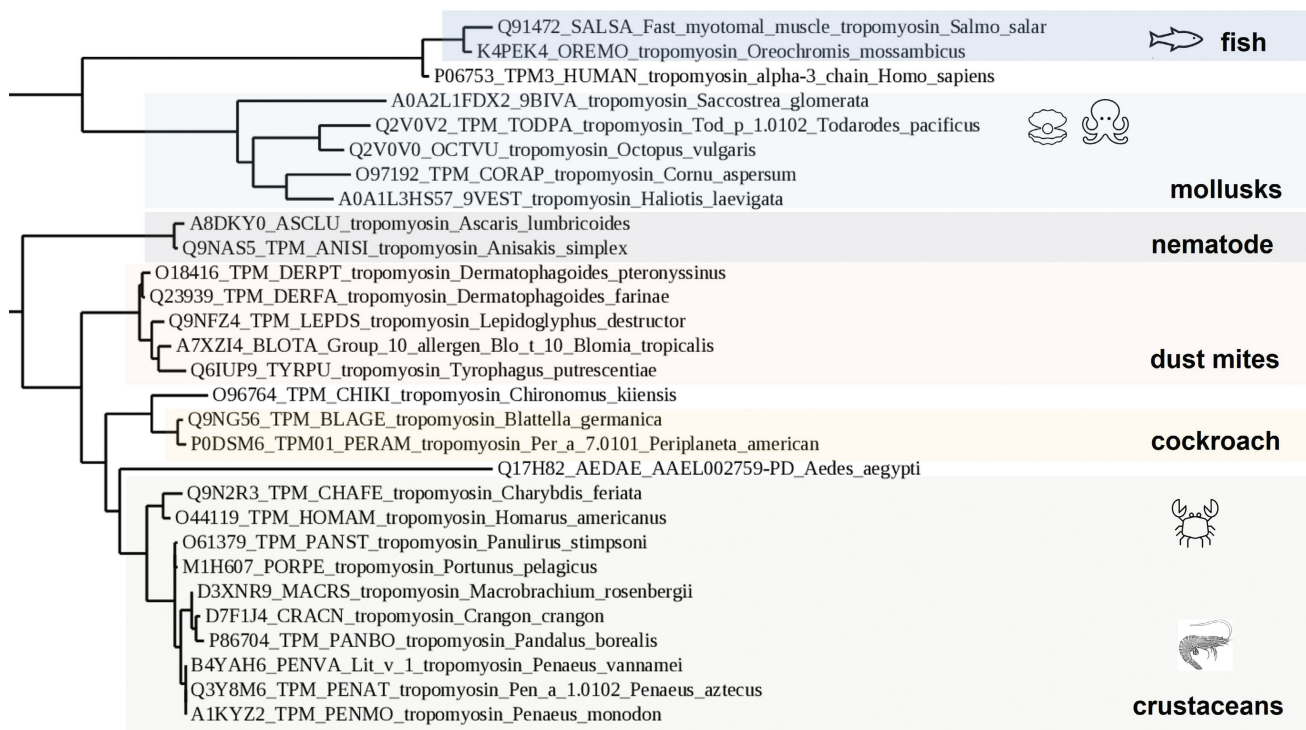


FIGURE 162 Phylogenetic tree of allergenic tropomyosins

In Europe, sensitization to mite tropomyosin Der p 10 is low (8–18%¹⁵⁰⁶) and has been considered an effect of cross-reactivity but also a marker for broad sensitization among HDM allergy patients. However, the prevalence of sensitization to Der f 10 was found around 80% in Japan. In addition, sensitization to Der p 10 was found 55% in Zimbabwe and 34% in Colombia,⁷⁷⁵ probably because of perennial exposure to shellfish and helminth infections. Therefore, the clinical impact of nonfood allergenic tropomyosins may be greater than previously thought. It has been suggested that sensitization to tropomyosin from mite,⁷⁷⁵ cockroach, *Ascaris*^{775,1501} and mosquito^{1494,1507} could influence the prevalence and severity of asthma in places where co-exposure to several sources of tropomyosin occurs. Also, sensitization to HDM tropomyosin seems to be a risk factor for shrimp allergy in Italian patients.¹⁵⁰⁸ The influence of *Ascaris* tropomyosin sensitization on the outcome of immunotherapy for mite allergy has not been evaluated.

The frequency of IgE sensitization to tropomyosins in shellfish allergic patients ranges from 50 to 100%. In addition, Pen a 1 binds up to 75% of all shrimp-specific IgE antibodies,¹⁴⁸⁴ which is supported by histamine release experiments.¹⁴⁸³ Seafood allergy is common and includes reaction to crustaceans, mollusks and fish.¹⁰¹⁵ In some regions of high consumption such as Singapore and Vietnam, the prevalence of seafood allergy in school children is about 5%. In the USA, shellfish allergy is the most common food allergy among adults with 4% and the third most common food allergy in children.¹⁰⁷⁷ It remains to be evaluated how 62% of nonasthmatic controls are sensitized to *Ascaris* tropomyosin (Asc I 3) without allergic symptoms neither to HDM or shrimp.⁷⁷³

Family characteristics

- Secondary structure formed by two parallel alpha-helices
- High amino acid identity between sequences of different species
- High degree of immunological and clinical cross-reactivity between different species
- Thermostable proteins, high allergenicity
- Considered invertebrate pan-allergen

4 – Clinical management

Clinical history of adverse reaction suggesting allergy after intake of shellfish is crucial for starting diagnosis procedures.¹⁰¹⁸ Whole extracts are beneficial for diagnosing shellfish allergy by ST, although the Prick-by-prick procedure is also useful. Tropomyosin sensitization is very important when evaluating shellfish allergy, but other allergens also play a role.^{1015,1491} It has been suggested that *in vitro* determination of IgE antibodies to tropomyosin is more specific and has a higher positive predictive value than the whole

extract in cases of shrimp allergy. In addition, Thalayasingam et al. found that the presence of specific IgE to shrimp has diagnostic test sensitivity of 82% and specificity of 22.2%.¹⁰⁸⁶ This low specificity, mainly due to the high rate of false positives that in turn are a consequence of the high cross-reactivity between shrimp and other arthropods allergens, explains why an allergy to shellfish should often be diagnosed by an oral food challenge. Two shellfish tropomyosins (Pen a 1 and Pen m 1, both from shrimp), Der p 10 (*D. pteronyssinus* tropomyosin), Ani s 3 from *Anisakis* and Per a 10 from cockroach are commercially available for *in vitro* testing. Diagnostic steps (Figure 163) could be starting with ST with the whole extract, and detecting IgE antibodies to the extract, tropomyosin and other shellfish allergens, such as Pen m 2 (Arginine kinase), Pen m 4 (Sarcoplasmic calcium-binding protein), Pen m 3 (Myosin light chain) and Pen m 6 (Troponin C).

Since most shellfish tropomyosins share sequences and epitopes (cross-sensitization) and there is a great diversity of seafood (co-sensitization), it is currently difficult to define the primary allergenic source using component-resolved diagnosis. Then the added value of using single allergens for distinguishing the sensitizing source is limited because there are no species-specific markers of sensitization. However, a panel of tropomyosins from different species (e.g., shrimp, *Anisakis*, house dust mite, could be useful for comparing sensitization patterns from patients with different symptoms or severity of symptoms and identifying clinically useful biomarkers. Pascal M et al. evaluated, in patients from the USA, Brazil and Spain, the efficiency of several allergens to predict shrimp allergy. They found that tropomyosin and sarcoplasmic-calcium-binding protein sensitization is associated with clinical reactivity; in addition, the tropomyosin epitope p51-55 seems to be of good value as a diagnostic test to confirm allergy. The authors present a very interesting flow diagram for shrimp allergy diagnosis.¹⁵

Still, the gold standard for food allergy diagnosis is the double-blind placebo-controlled food challenge. An essential aspect of management is the detection of tropomyosin in food samples to prevent accidental ingestion and anaphylactic reactions. Several approaches and techniques have been proposed.

Management of shellfish allergy is based on strict avoidance based on clinical reactions. In general, if a patient is allergic to shrimp, avoiding of all crustaceans is recommended, although allergy may be limited to a particular crustacean member. Avoidance of mollusks is advised if allergy is demonstrated. However, patients with high IgE reactivity to tropomyosin might be advised to avoid all shellfish. No immunotherapy is currently available for seafood allergy, but experimental approaches to obtain appropriate compounds for specific immunotherapy have been developed. Hypoallergenic Pen a 1, hypoallergenic peptides from Met e 1, periodate treatment of crab tropomyosin and simulated gastric digestion of the whole shrimp extract are analysed. Animal models for sensitization will help to obtain better reagents for diagnosis and treatment.

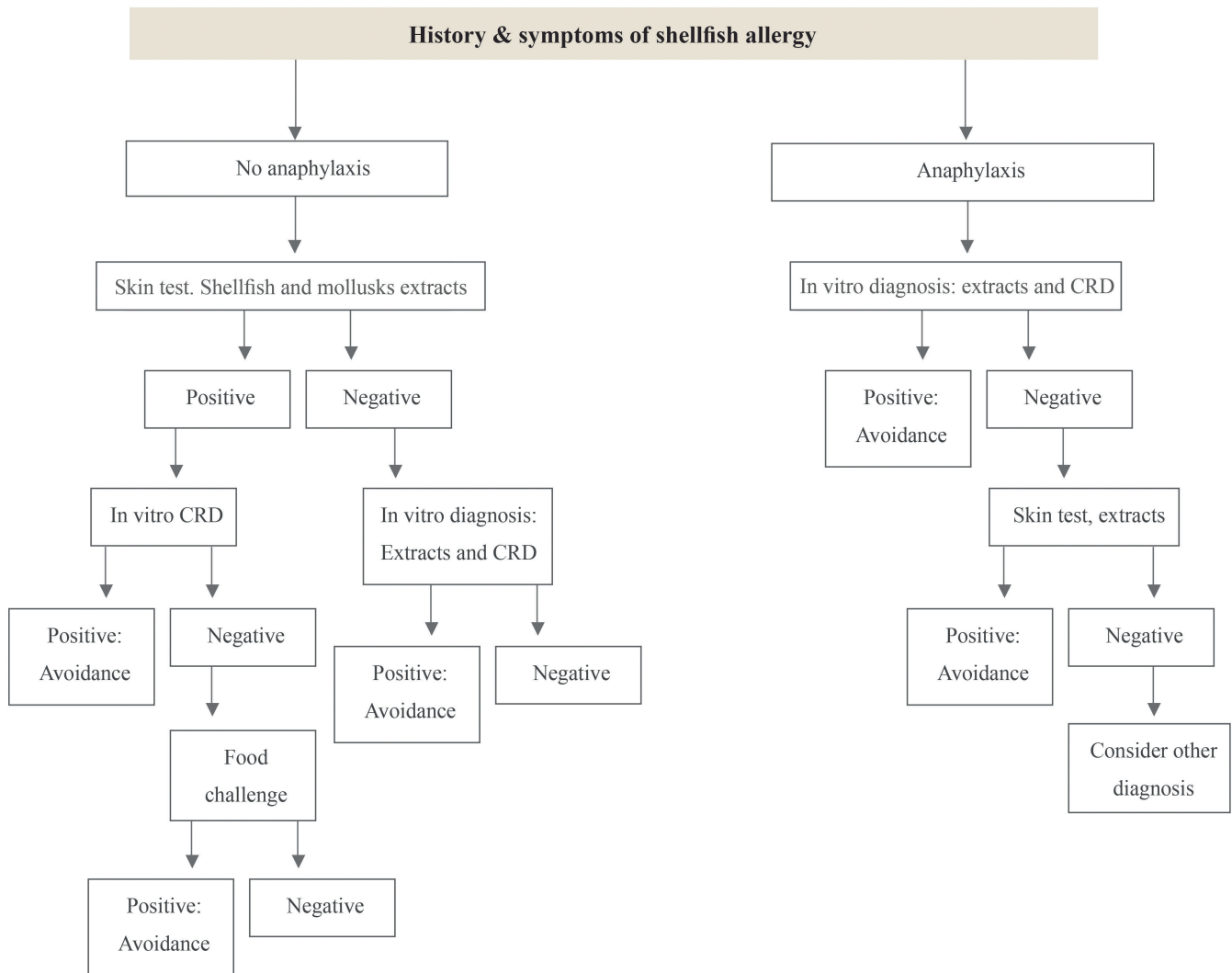


FIGURE 163 Diagnostic algorithm for shellfish allergy. *In vitro* tests for IgE to molecular allergens (CRD) include Pen a 1, Pen m 2, and Pen m 4. C06

5 – Clinical Cases

Case 1 (published)¹⁵⁰⁹

Clinical History: A 30-year-old man with a 10-year history of mild persistent asthma and allergy to house dust mites and pollen had generalized urticaria, facial erythema, and pharyngeal pruritus after eating shellfish on three separate occasions during two years. He associated the most recent episode with lobster. Since then, he has tolerated some crustaceans, mollusks, and fish, although he has avoided eating shrimp and lobster. No other food or drug allergies were reported, and he has not received immunotherapy for house dust mites.

Test with extracts: The patient had positive results using *in vitro* commercial diagnostics for *D. pteronyssinus* (21.4 kU/L) and *D. farinae* extracts (12.6 kU/L). Weak positive SPT to shrimp and IgE to lobster extracts (2.9 kU/L) and PPT to lobster were positive (6 mm).

Food challenge: The patient tolerated up to 8 g of cooked shrimp during the challenge (regular servings have been tolerated several times since). The study performed with lobster gave positive results by ImmunoCAP Specific IgE test (2.9 kU/L) and PPT (6 mm). However, the patient refused the oral food challenge with lobster.

Test with molecules: The patient had positive results to Der p 1 (4.7 kU/L), Der p 2 (60.9 kU/L), Der f 1 (0.4 kU/L) and Der f 2 (47.2 kU/L). Purified tropomyosins from shrimp (Pen a 1) and *D. pteronyssinus* (Der p 10) were negative.

Conclusion: Selective allergy to lobster in a patient with primary sensitization to house dust mite.

6 – Research and future perspectives

There are several aspects of tropomyosin allergy that deserve further investigation. Since allergen specific immunotherapy for food allergy

is increasing, the search for better reagents, both from extracts or isolated tropomyosin molecules should be encouraged. This process involves the identification of specific T and B cell epitopes, specially those associated with clinical manifestations. The molecular evaluation of the role of tropomyosins on allergic reaction following ingestion of edible insects will be essential for managing these problems,

not only in Asia, but in Western countries where the epidemiological impact has to be also analysed. As with other allergens, the search for genetic variants associated with both tropomyosin sensitization and allergic reactions will improve the understanding of basic mechanisms underlying the IgE response and our capacity for managing patients under personalized medicine criteria.

C06 – Polcalcins

Joaquín Sastre, Marcela Valverde

Highlights

- Polcalcins are EF-hand calcium-binding proteins.
- Extensive IgE cross-reactivity among pollen polcalcins.
- Specific IgE testing to pollen polcalcin can be performed with any member of the family.
- Can be considered as marker of polysensitization with unknown clinical relevance for respiratory symptoms.

1 – The protein

The most representative pollen polcalcin and the first cloned¹⁵¹⁰ is Phl p 7 from *Phleum pratense* (common timothy). Phl p 7 belongs to a subfamily of 2-EF-hand calcium-binding pollen allergens that are preferentially expressed in mature pollen of higher plants including monocotyledonous and dicotyledonous species (Figure 164)

Phl p 7 was detected only in pollen but not in root and leaf extracts. It is completely eluted out of the pollen grains after a few minutes of hydration. It contains 78 amino acids with a molecular weight of 8,677 Da. A summary of the biochemical characteristics of Phl p 7 is shown in Table 88.

The physiological role of Phl p 7 is likely related to regulate the calcium levels in pollen germination and pollen tube growth, as other calcium-binding proteins contained in pollen.

Recombinant Phl p 7 exhibits an allergenic activity and is able to induce basophil histamine release and immediate type skin reactions. Phl p 7 has high stability (thermal and proteolysis)^{1510,1511} and refolding capacity, a characteristic related to relevant allergens. It contains calcium-modulated conformational IgE epitopes, which

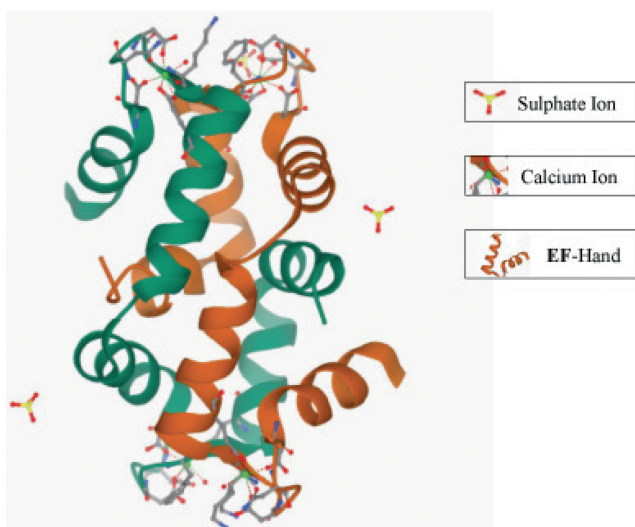


FIGURE 164 Ribbon model of the three-dimensional structure of Phl p 7. pdb: 1K9U. February 2022.

TABLE 88 Protein characteristics of Phl p 7

Protein characteristics of Phl p 7	
Allergen source	<i>Phleum pratense</i> (common timothy)
Protein family	Polcalcin
UniProtKB accession	O82040
Crystal structure	https://www.rcsb.org/structure/1K9U
Molecular structure	alpha-helical fold
Theoretical molecular weight	8,677 Da
Length	78 amino acids, mature protein
Ligand binding	EF-hand calcium binding allergen
Dimerization	Dimer or monomer
Glycosylation	no
Disulfide bonds	no
Isoelectric point	4.39
Synthesis	Pollen grains
Function	Regulation of pollen germination and pollen tube growth

become accessible only in the calcium-bound form (open conformation), suggesting that IgE recognition is only activated by the calcium-bound conformation (Figure 164)

Family characteristics

- Common tertiary structure with alpha-helical fold
- Calcium-binding capacity
- High sequence identity (average 77%)
- Small molecules of around 8 kDa
- Conformational IgE epitopes (calcium-modulated)
- Extensive IgE cross-reactivity among pollen polcalcins

2 – The family

Polcalcins belong to the 2-EF-hand calcium-binding proteins. Some polcalcins are monomers while others form domain-swapped dimers.

To date, 40 members of this allergen family have been identified in grasses, trees, bushes, weeds, and other flowering plants (Table 89) (see chapters B01, B02, B03) (Figure 165).

The 2-EF-hand allergens share a high degree of sequence similarity (average sequence identity of 77%), which explains the extensive cross-reactivity of allergic patients' IgE with the various members of the family. Although they do not present a complete immunological equivalence, the diagnosis of patients sensitized to polcalcins can be performed with any member of the family.¹⁵¹⁰ The IgE-binding capacity of polcalcins depends on conformational epitopes.¹⁵¹⁰ It has been demonstrated that Phl p 7 and related two EF-hand allergens do not share epitopes with other 3-EF-hand calcium-binding proteins allergens (e.g., Bet v 3, parvalbumins Gad c 1 or carp Cyp c 1) or 4-EF-hand calcium-binding proteins allergens (Ole e 8, Jun o 4, Amb a 10).

TABLE 89 Allergenic polcalcins described

Botanical family	Allergen source	Allergen
Asteraceae	Short ragweed <i>Ambrosia artemisiifolia</i>	Amb a 9 Amb a 10 *
	English mugwort <i>Artemisia vulgaris</i>	Art v 5
	Sieversian wormwood <i>Artemisia sieversiana</i>	Art si 5
Betulaceae	Birch <i>Betula verrucosa</i>	Bet v 3 * Bet v 4
	Alder <i>Alnus glutinosa</i>	Aln g 4
Brassicaceae	Rapeseed <i>Brassica napus</i>	(Bra n 7)
	Block choy Bird rape <i>Brassica rapa</i>	Bra r 5
Chenopodiaceae	Goosefoot <i>Chenopodium album</i>	Che a 3
	Russian thistle <i>Salsola kali</i>	Sal k 7
Cupressaceae	Arizona cypress <i>Cupressus arizonica</i>	(Cup a 4) *
	Prickly juniper <i>Juniperus oxycedrus</i>	Jun o 4 *
Oleaceae	Ash <i>Fraxinus excelsior</i>	(Fra e 3)
	Olive <i>Olea europaea</i>	Ole e 3 Ole e 8 *
	Common lilac <i>Syringa vulgaris</i>	Syr v 3
Poaceae	Bermuda grass <i>Cynodon dactylon</i>	Cyn d 7
	Timothy grass <i>Phleum pratense</i>	Phl p 7
Urticaceae	Pellitory <i>Parietaria judaica</i>	Par j 4

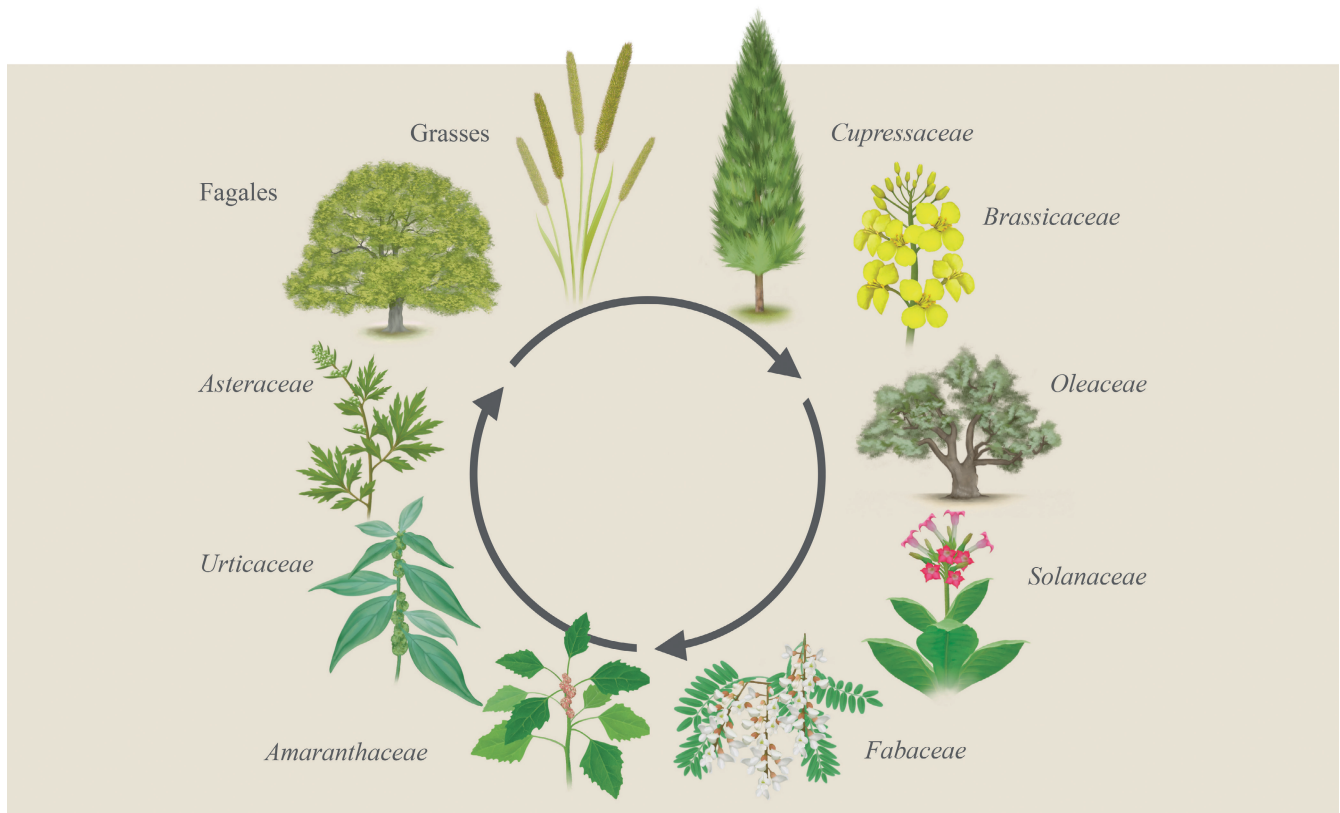


FIGURE 165 Cross-reactivity among polcalcins from different allergenic sources.

3 – Clinical relevance

Members of this protein family have been identified as allergens. However, it is considered a minor allergen in all populations studied, since the reported frequencies of IgE binding to members of this family of proteins varies between 5% and 46%. Che a 3, a polcalcin from *Chenopodium album*, common in semi-desert areas, is an atypical polcalcin because it showed reactivity up to 46% of sera from individuals with chenopod allergy.¹⁵¹² The high prevalence of this pan-allergen in these patients might have a relationship with their characteristic polysensitization (Table 90). Moverare et al.¹⁵¹³ compared different European populations regarding the reactivity of Bet v 4 and found prevalence values between 5% and 11% for patients from North and Central Europe, and 27% for Italian patients. All these data point to the existence of a certain correlation between the polysensitization degree and geographical area and prevalence of sensitization to minor allergens. In Table 90 the percentage of sensitization to different polcalcins in patients with pollen allergy are shown. Barber et al.²⁸⁰ described that in patients who were simultaneously sensitized to

polcalcins and profilins, there was a duplication both in the number of sensitizations to major allergens and in the years of disease evolution. Similar findings were obtained by Orovitg et al.¹⁵¹⁴ Moreover, this specific sensitization profile is not linked to any particular pollen.^{280,1515,1516} Therefore, sensitization to polcalcin should be considered a marker of a longer duration of symptoms and a more severe respiratory disease. Nevertheless, contrary to profilin,^{1397,1412} the relevance of polcalcin to induce respiratory symptoms has not been demonstrated.

4 – Clinical management

Polcalcins are only expressed in pollen, thus are not related to food allergy, contrary to other pan-allergens such as profilin or nsLTPs. It is considered as a pan-allergen and therefore could be a confounding factor in the diagnosis of polysensitized pollen-allergic patients and may lead to a diagnosis of “allergy mirages”^{1397,1517} (Figure 166). Through IgE inhibition assays, Asero et al. found important differences in IgE reactivity between rBet v 4 and rPhl p 7, since only grass pollen extract was able to markedly inhibit rPhl p 7. By contrast, other pollen extracts (birch, ragweed, olive, Parietaria) significantly inhibited IgE reactivity to rBet v 4.^{1412,1421} That suggests that in some areas the primary source of sensitization for polcalcin is grass pollen. Polcalcins are not commercially available for SPT. However, in some research articles, an extract derived from palm pollen has been used and prepared by ALK (Madrid, Spain).^{1412,1421} Recently a method to purify the olive polcalcin, Ole e 3, has been described.^{1517,1518} For specific IgE determinations, there are only three polcalcins available; Phl p 7, Bet v 4 and Aln g 4. The diagnosis of patients sensitized to polcalcins can be performed with specific IgE to Phl p 7 or Bet v 4. The presence of polcalcin sensitization in patients with pollen allergy does not require to change the clinical indications for immunotherapy and does not have to be considered a contraindication. Only grass pollen extracts used in AIT are rich in polcalcin.¹⁴²¹

TABLE 90 Prevalence of polcalcin sensitization in patients with pollen allergy

Main sensitisation of the population studied	Prevalence of sensitisation to Polcalcin	Reference
Birch	Bet v 4: 5%	[1518]
Chenopodium/Salsola	Che a 3: 46%; Che a 3: 41%	[1512, 1709]
Olive	Ole e 3: 20-30%	[1514]
Grass	Phl p 7: 2-10%	[85, 86, 1514]
Alder	Aln g 4: 18%	[1710]
<i>Robinia pseudoacacia</i>	Che a 3: 33%	[1397]
Ash	Fra a 3: 16%	[1711]
Cypress	Cup a 4: 10%	[1712]
Polysensitized to pollen	Polcalcin: 31%	[1412]
Birch, ash, mugwort, grass	Polcalcin: 10%	[1515]

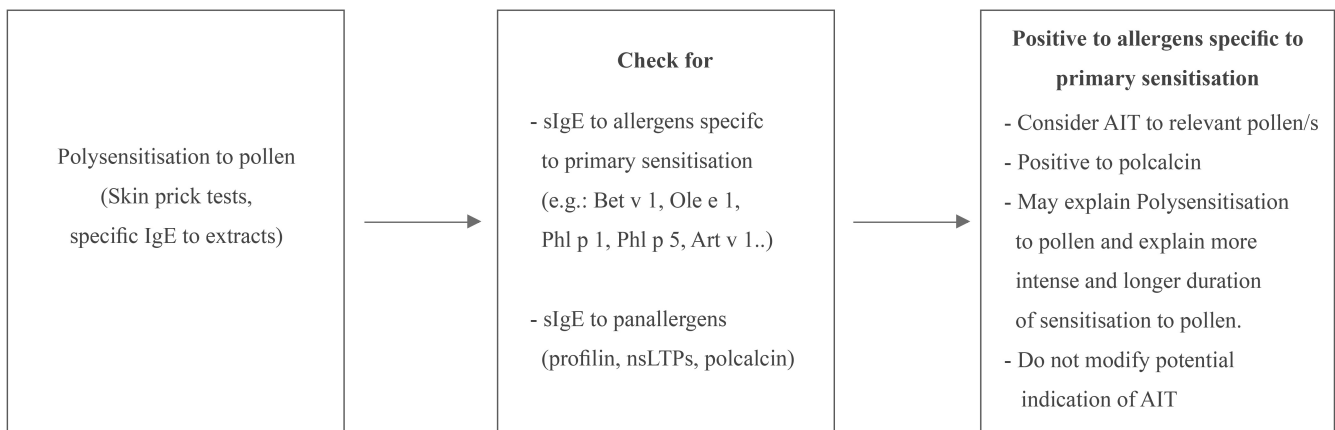


FIGURE 166 Scheme to follow in case of polysensitization to pollen. Added value of the use of specific IgE to species-specific pollen allergens and to pan-allergens

5 – Clinical case

Clinical History: Male, 26 years, with a 10-year history of rhinitis and asthma during spring. No complaint of adverse reaction to food.

Test with extracts: Skin prick test showed positive reaction to grass, olive, cypress and plantain. Due to extensive polysensitization to pollen a molecular diagnosis was performed to give an indication for immunotherapy.

Test with molecules: Specific IgE was positive for Phl p 1, Phl p 5, Phl p 12, Phl p 7 and negative for Ole e 1, Cup a 1, Pla l 1.

Conclusion: Results indicate a primary sensitization only to grass pollen and pan-allergens (profilin and polcacin), which confirm a longer duration of the respiratory symptoms and the severity of the disease. Immunotherapy with a grass pollen extract was prescribed.

C07 - Lipocalins

Bente Janssen-Weets, Christiane Hilger

Highlights

- Common tertiary structure with low sequence identity among family members.
- Airborne, easily spreading into indoor environment.
- Sensitization to multiple components is associated with disease severity.
- Cross-reactive subgroup with high sequence identity.

1 - The protein

Equ c 1, the major allergen of horse, was one of the first lipocalins to be isolated, cloned and characterized (Table 91).¹⁵¹⁹ The determination of its three-dimensional structure classified it as lipocalin (Figure 167).¹⁵²⁰ The physiological role of Equ c 1 is still under investigation. Lipocalins have diverse functions that are often associated with their ability to transport ligands. Equ c 1 purified from horse sweat contains oleamide, an endogenous bioactive substance, and other small organic molecules. Equ c 1 was found to have surfactant properties; it lowers the surface tension of liquids and could play a role in sweat evaporation.¹⁵²¹ Horse allergens are shed into the air and are passively transported to homes and public places, most likely by sticking to clothes and hair.^{1376,1522} They are detectable in classrooms when many children have regular contact with horses.¹⁵²¹

Equ c 1 has been detected in the majority of air-borne dust samples in small animal veterinary practices and their employees' homes,

TABLE 91 Protein characteristics of Equ c 1

Protein characteristics of Equ c 1	
Allergen source	<i>Equus caballus</i> , horse
Protein family	lipocalin
UniProtKB accession	Q95182
Crystal structure	yes
Molecular structure	mainly beta-sheet
Theoretical molecular weight	20.097 kDa
Molecular weight measured by mass spectrometry	22.0 kDa
Length	187 amino acids, mature protein 172
Ligand binding	yes
Dimerization	homodimer
Glycosylation	yes
Disulfide bonds	1
Isoelectric point	4.51
Synthesis	sublingual gland, low levels in submaxillary gland and liver, secreted
Distribution	fur, saliva, urine

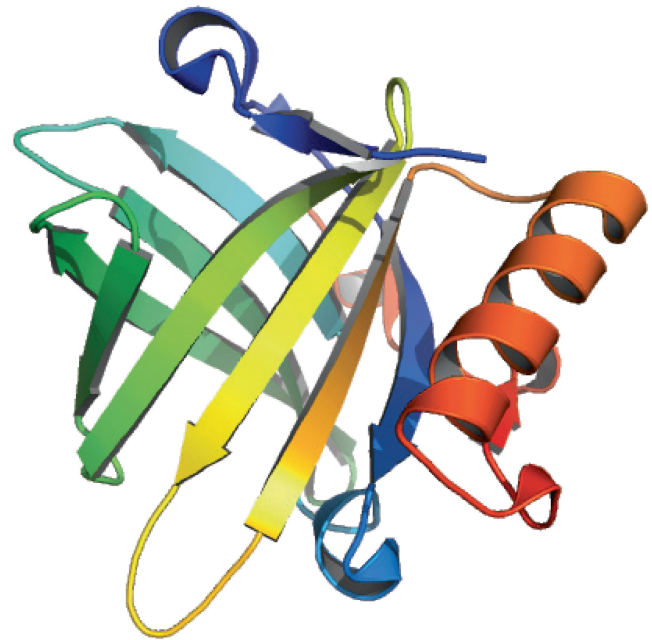


FIGURE 167 Ribbon model of the three-dimensional structure of Equ c 1 (PDB: 1EW3). N-terminal end in dark blue, C-terminal end in red.

although horses were not treated there. The highest Equ c 1 concentrations were found in the practices changing rooms, suggesting an important spreading of allergens via passive transfer.⁸²⁰ Gender and castration status seem to influence allergen content in horse hair. Statistically, stallions have higher quantities of Equ c 1 than mares and geldings.⁷⁹⁴

The characterization of B and T cell epitopes is still under investigation. T-cell epitopes seem to cluster in an immunodominant region at the carboxy-terminal end of the molecule.¹⁵²⁴ Attempts to develop hypoallergenic Equ c 1 variants for immunotherapy also target its dimerization interface.¹⁵²⁵ Data on horse immunotherapy with extracts are scarce and larger clinical trials are needed for assessing efficacy and safety of the treatment.

2 - The family

The majority of the mammalian allergens are lipocalins³⁴⁵ (Table 92). Lipocalins are proteins that are ubiquitous; they are present also in arthropods, plants and bacteria, and have very diverse functions. They are characterized by a common tertiary structure composed of a central β -barrel formed of eight anti-parallel β -strands. The internal binding pocket carries a broad range of small hydrophobic molecules such as retinol, steroids, lipids, pheromones and odorants (see chapter A11). Mammalian allergens isolated so far are mostly odorant and pheromone binding lipocalins. Only few natural ligands have been characterized.

Depending on the individual protein and its concentration, lipocalins exist as monomers or in an oligomeric state. Most of them are glycosylated. Lipocalins are characterized by a weak cellular immune

TABLE 92 Respiratory and food lipocalin allergens from mammals

Family	Allergen source	Allergen
Bovidae	Domestic cattle (<i>Bos domesticus</i>)	Bos d 2
		Bos d 5
Canidae	Dog (<i>Canis familiaris</i>)	Can f 1
		Can f 2
		Can f 4
		Can f 6
Cavidae	Guinea-pig (<i>Cavia porcellus</i>)	Cav p 1
		Cav p 2
		Cav p 3
		Cav p 6
Cricetidae	Golden hamster (<i>Mesocricetus auratus</i>)	Mes a 1
		Phod s 1
Equidae	Domestic horse (<i>Equus caballus</i>)	Equ c 1
		Equ c 2
Felidae	Cat (<i>Felis domesticus</i>)	Fel d 4
		Fel d 7
Leporidae	Rabbit (<i>Oryctolagus cuniculus</i>)	Ory c 1
		Ory c 4
Muridae	Mouse (<i>Mus musculus</i>)	Mus m 1
		Rat (<i>Rattus norvegicus</i>)

response and their mechanism of sensitization remains largely unresolved.²⁶ It has been hypothesized that the binding of ligands might influence their allergenicity. For example, the milk allergen Bos d 5 is able to bind complexed iron. The state of ligand load and the transport of iron to sites of immune activation seem to have a tolerogenic effect.⁴⁶⁶ The dog lipocalin allergen Can f 6 may display immunomodulatory properties when combined with lipopolysaccharide ligands by enhancing Toll-like receptor 4 signaling of the innate immune system.³¹⁸

Lipocalin allergens are present in dander, saliva and urine. They stick to particles, become easily airborne and are transported to public places such as schools or day-care centres.^{820,1376,1672} Dog lipocalin allergens Can f 6 and Can f 4 were found to distribute evenly in airborne fractions of different particle size ranging from 0.14 to >8.1 µm, whereas the majority of Can f 1 molecules seem to stick to particles above 8.1 µm.^{1526,1527}

Lipocalins are small, secreted molecules of 150-250 amino acids. Among 10 allergen families, lipocalins were ranked lowest according to their propensity for cross-reactivity based on the average of the proteins' sequence similarity and identity.¹⁵²⁹ Despite their highly conserved structure, they display little sequence identity, usually between 20 and 30%. Therefore, lipocalins were considered as species-specific allergy markers. Residues and their positions that are of structural and functional importance are conserved through evolution and can be the potential target for IgE cross-reactivity between homologous allergens (Figure 168). The further isolation of new allergen molecules showed that some lipocalins have much higher sequence identities, which can be as

high as 67%. In inhibition studies, they were able to cross-react at low doses.^{814,821,1529} Representatives of this cross-reactive group are Equ c 1, Fel d 4 and Can f 6.⁸²¹ Only lately, Cav p 6 was found to be cross-reactive with Fel d 4 and Can f 6 as well.⁸²² Can f 1 and Fel d 7 also share a high sequence identity (62%) and IgE cross-reactivity was recently confirmed in polysensitized patients.^{1530,1531} However, even between molecules of low general sequence identity such as Fel d 4 and Can f 2 (25% identity), single epitopes may have short stretches of sequence identity and lead to patient-dependent IgE cross-reactivity.¹⁵³² Can f 4 has been reported to show some cross-reactivity with a putative bovine allergen sharing only 37% of sequence identity.¹⁵³³ Table 93 displays two-by-two comparisons of amino acid identities between a subgroup of lipocalins.

Family characteristics

- Common tertiary structure with central barrel
- Divergent sequences with low identity
- Sub-group with high sequence identity
- Small secreted molecules of 16-25 kDa
- Airborne, easily spreading into indoor environment

All pairs with a high sequence identity are potentially cross-reactive. The challenge of further studies is to analyze which lipocalins are adequate species-specific markers and which are

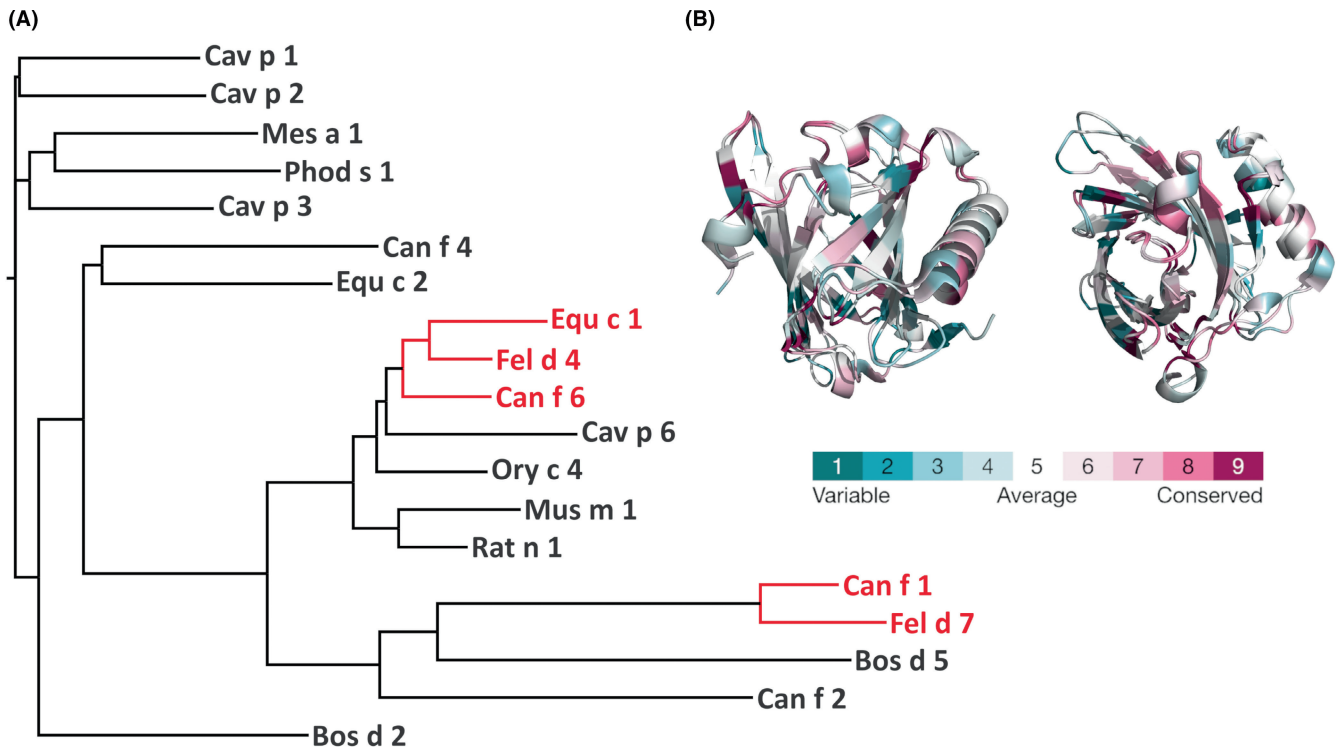


FIGURE 168 Lipocalins: Highly conserved tertiary structures in a protein family of high amino acid sequence diversity. (A) Phylogenetic tree of mammalian lipocalin allergens (Marked in red: Cross-reactive molecules of high clinical relevance). (B) Superimposition of Equ c 1 (1EW3) and Can f 4 (4ODD) crystal structures (side view and bottom view into the calyx) show a highly similar tertiary structure despite their low amino acid sequence identity (30%). Evolutionary conservation patterns were analyzed using the ConSurf software¹⁶⁷² and based on a multiple sequence alignment (Clustal Omega) comprising 19 identified mammalian derived lipocalin allergens. Slowly evolving, highly conserved amino acid positions are colored in maroon (grade 9), whereas rapidly evolving variable positions are colored in turquoise (grade 1).

TABLE 93 Amino acid identities (%) between lipocalins with high sequence identity

Equ c 1									
Fel d 4	67								
Fel d 7	26	20							
Can f 1	28	26	62						
Can f 6	57	67	25	26					
Cav p 6	48	53	24	24	53				
Mus m 1	46	49	22	21	47	45			
Ory c 4	52	63	25	24	58	49	51		
Rat n 1	47	55	24	23	52	50	64	54	
	Equ c 1	Fel d 4	Fel d 7	Can f 1	Can f 6	Cav p 6	Mus m 1	Ory c 4	Rat n 1

Blue shaded areas indicate lipocalin pairs with >50% amino acid sequence identity. Figures in bold blue indicate documented IgE cross-reactivity between lipocalins.

markers of cross-reactivity. Sequence alignments are good primary prediction tools for cross-reactivity, even more so when combined with structural information. Nevertheless, the use of IgE-inhibition studies with sera from well-characterized patients is of most importance when defining clinically relevant cross-reactivity.

Figure 169 visualizes how a high amino acid sequence identity combined with a similar tertiary structure can result in large surface areas that form potential cross-reactive IgE epitopes.

The objective of further studies will be the identification of marker molecules for each animal species in order to clearly identify the sensitizing allergen source. Figure 170 shows documented and putative cross-reactive molecules.

3 – Clinical relevance

All mammalian lipocalin allergens are respiratory allergens, with the exception of the β -lactoglobulins (e.g., Bos d 5), which are present in milk.³⁴⁵ They are major allergens of different furry pets and are shed into the environment by animal dander and secretions. They stick to clothes and human hair and are passively transferred to public places.¹³⁷⁶ Allergens quantified in airborne dust in schools have been shown to attain levels that are able to sensitize children or to even stimulate asthma exacerbations. Domestic exposure to high levels of cat and dog allergens was associated with excess asthma attacks in sensitised patients.⁵⁵⁷

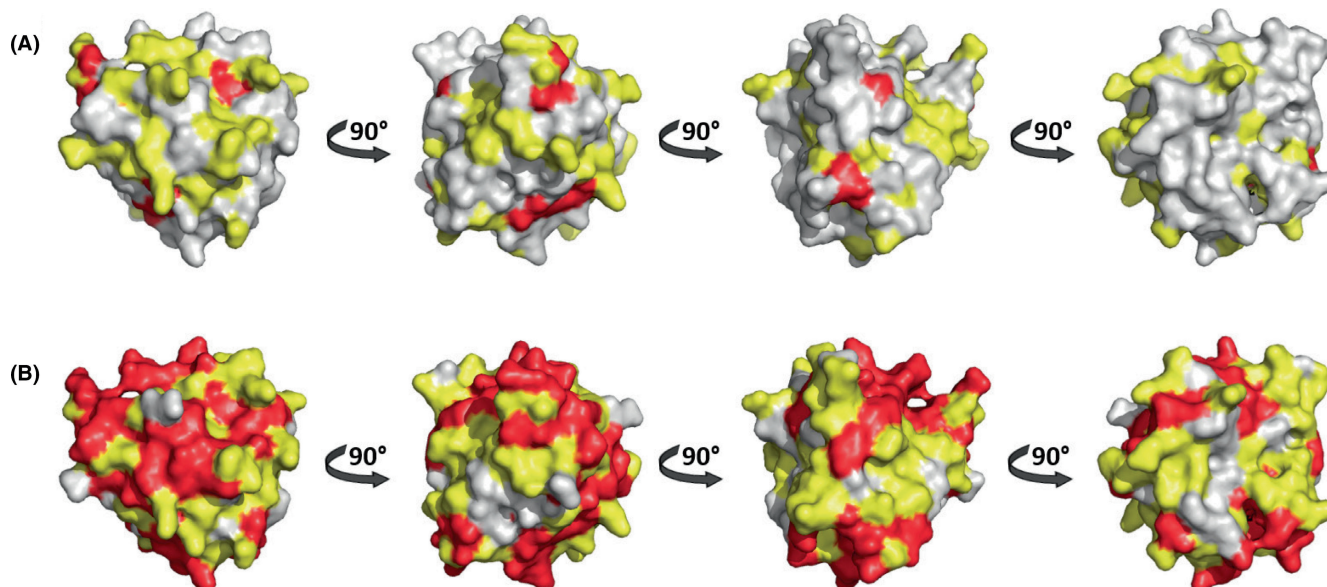


FIGURE 169 Interspecies cross-reactive lipocalins: The dog allergen Can f 6 shares higher amino acid sequence identities with its homologues derived from cat and horse than with lipocalin allergens within its own species. Surface representation of the dog allergen Can f 6 (6NRE) showing potential cross-reactive IgE epitopes. (A) Amino acid sequence identities between Can f 6, Can f 1 and Can f 2. (B) Amino acid sequence identities between Can f 6, Equ c 1 and Fel d 4. Identical amino acid residues between 3 lipocalin allergens are colored in red. Identical amino acid residues between 2 out of 3 allergens are colored in yellow and non-overlapping residues are colored in gray.

The reduction in pet allergen exposures may significantly decrease asthma morbidity.

Up to 50% of the households in industrialized countries have a pet. Twenty-four percent of European households have a cat, 25% have a dog and about 6–8% own a small mammal. Particularly families with children more frequently own a pet.

Allergy to furry animals is considered a risk factor for development of asthma.⁷⁸³ The role of single allergen molecules as markers of severe or mild disease has been investigated in several studies.⁸⁰³ A general conclusion from those studies is that a *polysensitization* to several components of one allergen source and/or *polysensitization* to components of several furry animals are associated with a higher risk of asthma and rhinitis, as well as a predictor of disease severity. With respect to lipocalins, sensitisation to the dog lipocalins, in particular to Can f 4 and Can f 6, has shown to be associated with dog allergy.⁸¹¹ For details, please see chapter B06.

Clinical relevance

- Up to 50% of households have a pet
- Risk factor for respiratory symptoms and asthma
- Sensitization to multiple components is associated with disease severity
- No molecule based therapeutic approach available

For the moment, the best treatment seems to be allergen avoidance. However, this is not always feasible as the allergens are present in schools, day-care centres, and public places. Furthermore,

pets are kept in many households. Thus, severely allergic patients are facing the risk of social exclusion by trying to avoid the allergens. The only immunotherapies currently available are made of animal dander extracts. Results of subcutaneous immunotherapy (SCIT) have shown a benefit in cat-allergic patients with asthma and rhinoconjunctivitis.⁸⁰² Studies on dog SCIT are limited. Due to the more complex sensitization pattern in dog allergy and a high variation of allergen content in allergen extracts,²⁶¹ further efforts are needed to improve AIT for dog allergy.⁸⁰² Before being able to develop specific lipocalin vaccine reagents, much more research has to be done to investigate the mechanism related to their allergenicity.

4 – Clinical management

A careful record of the clinical history such as the presence of pets at home or regular pet contact is of great value. Skin prick test or specific IgE using animal dander will confirm animal sensitization. As animal dander contains cross-reactive molecules such as serum albumins, some of the cross-reactive lipocalins and potentially other cross-reactive molecules, it is important to define the primary allergenic source, especially if a specific immunotherapy is intended. Co-sensitization has to be distinguished from cross-sensitization. It is important to acknowledge that IgE cross-reactivity may not always imply clinical cross-reactivity.

At the current state of the art, Fel d 1, Fel d 7, Can f 1, Can f 2, Can f 4, and Can f 5 are commercially available species-specific markers of sensitisation, although sensitisation to Can f 1 is not a specific marker in case of co-sensitisation to cat. Can f 6 is a marker of potential cross-reactivity to cat or horse. Equ c 1 often cross-reacts with Fel

d 4 and Can f 6, Mus m 1 may cross-react with Rat n 1. If the clinical history does not allow a clear identification of the sensitising animal, the following decision tree (Figures 171–173) will help to orient the use of components. Unfortunately, the number of commercially available components is still limited. The coverage is rather good for cat and dog, but for others, not all allergens are available from all providers. Horse allergens Equ c 1 and Equ c 3 are both cross-reactive, Equ c 4 may be a specific marker, but this needs to be further evaluated. More recently, some allergens of small furry pets became available for component-resolved diagnosis of allergy to hamster, rabbit and guinea-pig.

5 – Clinical cases

Case 1 (published¹⁵³⁴)

Clinical history: A 24-year-old man presented at the clinic with a 14-year history of rhinitis and asthma when exposed to horses and a 2 years history of rhinitis when exposed to dogs.

Test with extracts: Specific IgE to horse dander were elevated (92 kU/L), they were moderate to dog (7.2 kU/L).

Test with molecules: Specific IgE were detected to Equ c 1 (18 kU/L). All commercially available dog allergens (Can f 1, 2, 3, 5) were

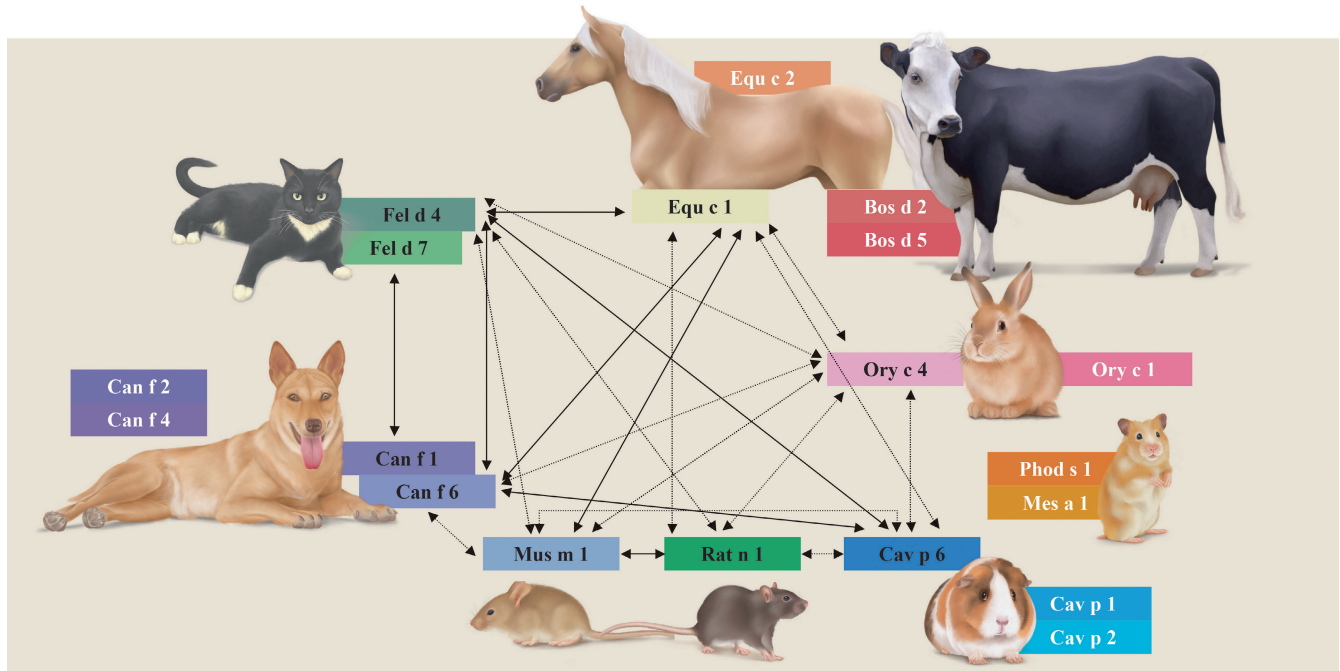


FIGURE 170 Cross-reactivities among allergenic lipocalins. Solid lines represent documented IgE cross-reactivity. Dotted lines represent potential IgE cross-reactivity based on high sequence identities. Allergens depicted in the outer circle (white font) show overall low sequence identities with other family members and are candidates for species-specific marker allergens, but their cross-reactive potential still needs to be investigated.

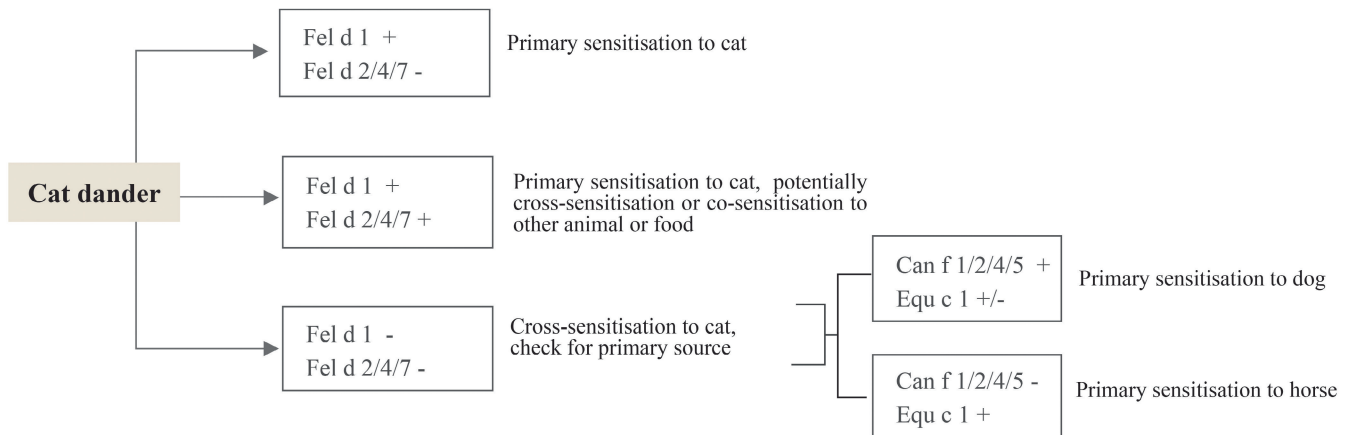


FIGURE 171 Single allergens are of added value to identify the primary sensitisation source in the case of a positive IgE test to cat dander.

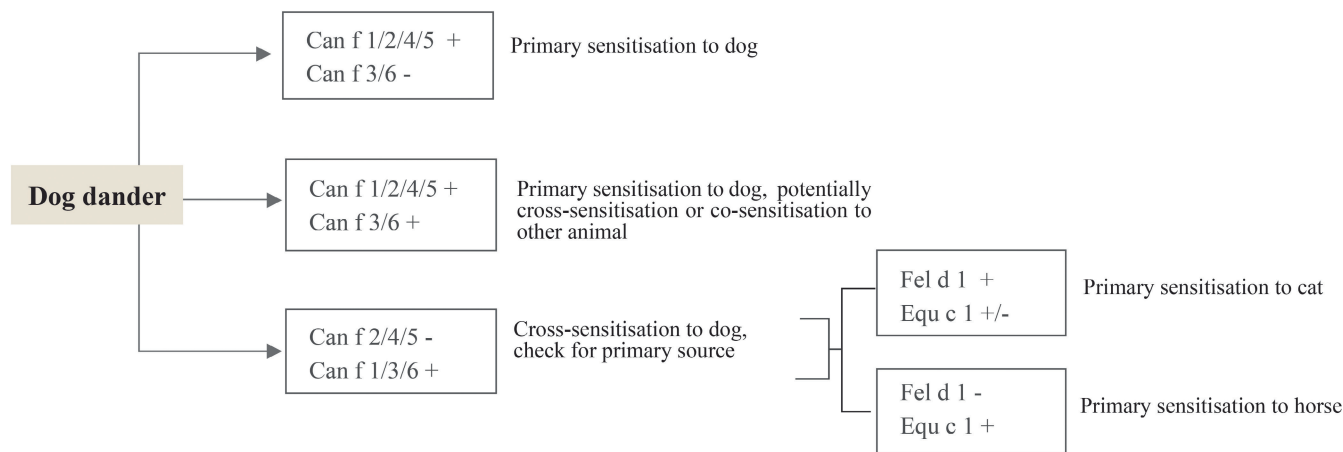


FIGURE 172 Single allergens are of added value to identify the primary sensitisation source in the case of a positive IgE test to dog dander.

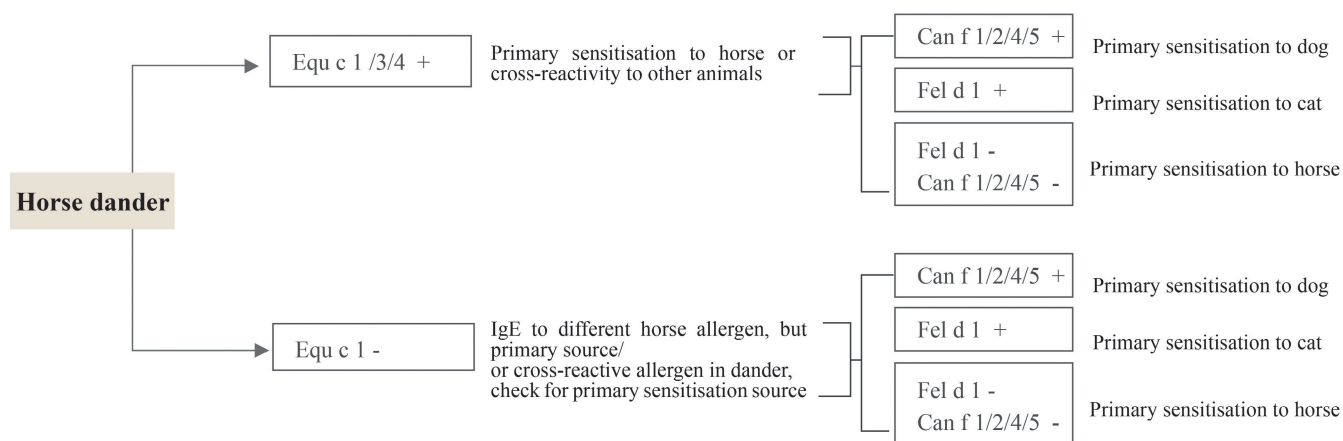


FIGURE 173 Single allergens are of added value to identify the primary sensitization source in the case of a positive IgE test to horse dander

negative. However IgE to Can f 6 were clearly positive (3.7 kU/L). Inhibition assays showed that IgE recognition of Can f 6 could be totally inhibited by low doses of Equ c 1.

Conclusion: In this particular case, clinical symptoms to dog were due to cross-reactivity of Can f 6 with Equ c 1.

Case 2 (published¹⁵²⁹)

Clinical history: A 30-year-old women had asthma upon exposure to her cat.

Test with extracts: Specific IgE were positive for cat (>100 kU/L) and dog dander (9 kU/L).

Test with molecules: The patient had specific IgE against Fel d 1 (51 kU/L) and Fel d 4 (51 kU/L), but Fel d 2, Can f 1, Can f 2, and Can f 3 were negative. Specific IgE to the cross-reactive Can f 6 were 18 kU/L. These could be completely inhibited by Fel d 4, suggesting cat as the primary allergen source.

Conclusion: Specific IgE were positive to cat and dog, but the presence of specific IgE to the marker allergen Fel d 1 and the absence of specific IgE to Can f 1 or Can f 2 confirmed that cat was the

primary allergen source and that Can f 6 was a IgE-cross-reacting allergen in dog.

Case 3 (published¹⁵²⁹)

Clinical history: A 53-year-old man presents with respiratory symptoms upon exposure to cat and dog.

Test with extracts: Specific IgE were positive for cat (65 kU/L) and dog dander (68 kU/L).

Test with molecules: The patient had specific IgE against Fel d 1 (35.8 kU/L), Fel d 2 (0.7 kU/L), Fel d 4 (45 kU/L), Can f 1 (26 kU/L), Can f 2 (13.5 kU/L), Can f 3 (0.2 kU/L) and Can f 6 (33 kU/L).

Conclusion: The presence of IgE to the specific markers Fel d 1, Can f 1 and Can f 2 argues for co-sensitization of cat and dog. Inhibition and cross-inhibition studies with Can f 6 and Fel d 4 showed weak inhibition, confirming the hypothesis of co-sensitization.

Allergen nomenclature: Fel d 1, cat secretoglobin; Can f 1, Can f 2, Can f 6, Equ c 1, Fel d 4, dog, horse and cat lipocalins; Can f 3, Fel d 2: dog and cat serum albumins; Can f 5, dog kallikrein.

C08 – Seed storage proteins

Merima Bublin, Christian Radauer, Anna M. Ehlers, Thuy-My Le

Highlights

- Seed storage proteins (2S albumins, 7S globulins and 11S globulins) are marker allergens for clinically relevant sensitizations to legumes, tree nuts and seeds.
- Not all relevant allergenic seed storage proteins are available for routine diagnosis.
- IgE cross-reactivity occurs between members of the same protein family most with allergens from related plants that show high protein sequence identities.
- IgE cross-reactivity may also occur between allergens from different families of seed storage proteins.
- The clinical relevance of IgE co-sensitization and the impact of cross-reactivity are largely unknown and still have to be studied using well-defined allergens together with primary material (serum, whole blood depending on the test) collected from well-characterized patients.

1 – The protein

Seeds comprise the most important constituents of the human diet, but they are also major elicitors of food allergies. Edible seeds are derived from botanically diverse types of plants such as cereals (e.g., wheat, rye, corn, rice see chapter B16), legumes (e.g., peanut, soybean, lentil chapters B17, B18), tree nuts (e.g., walnut, hazelnut) and others falling into neither of those categories (e.g., buckwheat, sesame, mustard chapter B19). Seeds are rich in protein, the most abundant of which are seed storage proteins whose main biological functions are to provide nutrients and energy sources for the germinating plant. Storage proteins of noncereal seeds can be classified into three protein families, the 2S albumins, the 7S globulins, also named vicilins, and the 11S globulins, also named legumins.¹⁵³⁵ All three families contain major allergens from legumes, tree nuts and other seeds. Sensitization to these allergens is often associated with severe reactions. Examples are Ara h 1, 2, 3, 6 and 7 from peanut, Jug r 1, 2, 4 and 6 from walnut and Ses i 1, 2, 3, 6 and 7 from sesame (Table 94). In addition, seed storage proteins may also elicit allergic reactions to certain fruits, such as tomato or kiwifruit, that contain small seeds usually eaten together with the fruit pulp. Cereal grains contain different types of storage proteins, the cereal prolamins, which are discussed in chapter B16.

2 – The families

2S albumins

2S albumins belong to the prolamin superfamily and are structurally related to the cereal bifunctional amylase and protease inhibitors (chapter B16) and the nonspecific lipid transfer proteins (nsLTPs; see chapter C03). Important members of this family are Ara h 2 and Ara h 6 from peanut, Jug r 1 from walnut, and Ses i 1 and Ses i 2 from sesame (Table 94). Most 2S albumins are composed of two disulfide-linked polypeptide chains that are generated by post-translational cleavage of a single polypeptide (Figure 174A), a small chain of about 4 kDa and a large chain of about 9 kDa (Table 95). Some members of this family consist of a single chain such as Ara h 2 and Ara h 6 from peanut. 2S albumins fold into compact α -helical bundles further stabilized by 4-5 disulfide bonds (Figure 175A). Apart from a conserved pattern of eight cysteine residues, sequences of 2S albumins from unrelated plants show very low sequence identities of less than 40% (Table 96).

2S albumin family characteristics

- Alpha-helical structure stabilized by disulphide bonds
- Low sequence conservation except a conserved cysteine skeleton
- Small, water-soluble molecules of about 15 kDa
- Highly stable against heat and digestion
- Present in all seeds of dicotyledonous plants

7S globulins

7S globulins (vicilins) and 11S globulins (legumins) are structurally related and belong to the cupin superfamily. Important allergenic vicilins are Ara h 1 from peanut, Gly m 5 from soybean and Jug r 2 from walnut (Table 94). Vicilins are composed of subunits of about 50 kDa in size (Table 95) folding into structures composed of two so-called cupin β -barrel domains surrounded by surface-exposed α -helices and unstructured loops (Figure 175B). These subunits form stable trimers of 150-190 kDa held together by noncovalent interactions (Figure 175C). In addition, many vicilins contain an N-linked glycan (Figure 174B). Sequences of vicilins from unrelated plants show only low levels of conservation with identities typically between 30% and 50% (Table 97).

During post-translational processing of vicilins, a large N-terminal propeptide is cleaved off and, in many cases, is not degraded but further processed into one or several shorter peptides with anti-microbial activity (Figure 174B). These peptides, known as α -hairpinins, contain a conserved cysteine pattern (CX₃CX₁₀₋₁₂CX₃C) and fold into an α -hairpin structure stabilized by two disulfide

TABLE 94 Seed storage proteins identified as allergens

Plant family	Allergen source	Allergen name		
		2S albumins	Vicilins (7S globulins)	Legumins (11S globulins)
Legumes				
<i>Fabaceae</i>	Peanut (<i>Arachis hypogaea</i>)	Ara h 2, Ara h 6, Ara h 7	Ara h 1	Ara h 3
	Soybean (<i>Glycine max</i>)	Gly m 8	Gly m 5	Gly m 6
	Pea (<i>Pisum sativum</i>)		Pis s 1, Pis s 2	
	Narrow-leaved blue lupine (<i>Lupinus angustifolius</i>)		Lup an 1	
	Lentil (<i>Lens culinaris</i>)		Len c 1	
	Mung bean (<i>Vigna radiata</i>)		Vig r 2	
Tree nuts				
<i>Juglandaceae</i>	English walnut (<i>Juglans regia</i>)	Jug r 1	Jug r 2, Jug r 6	Jug r 4
	Black walnut (<i>Juglans nigra</i>)	Jug n 1	Jug n 2	Jug n 4
	Pecan (<i>Carya illinoensis</i>)	Car i 1	Car i 2	Car i 4
<i>Betulaceae</i>	Hazelnut (<i>Corylus avellana</i>)	Cor a 14	Cor a 11	Cor a 9
<i>Rosaceae</i>	Almond (<i>Prunus dulcis</i>)			Pru du 6
<i>Anacardiaceae</i>	Cashew nut (<i>Anacardium occidentale</i>)	Ana o 3	Ana o 1	Ana o 2
	Pistachio (<i>Pistacia vera</i>)	Pis v 1	Pis v 3	Pis v 2, Pis v 5
<i>Lecythidaceae</i>	Brazil nut (<i>Bertholletia excelsa</i>)	Ber e 1		Ber e 2
<i>Proteaceae</i>	Macadamia nut (<i>Macadamia integrifolia</i>)		Mac i 1	Mac i 2
<i>Pinaceae</i>	Korean pine (<i>Pinus koraiensis</i>)		Pin k 2	
	Stone pine (<i>Pinus pinea</i>)	Pin p 1		
Other seeds				
<i>Pedaliaceae</i>	Sesame (<i>Sesamum indicum</i>)	Ses i 1, Ses i 2	Ses i 3	Ses i 6, Ses i 7
<i>Linaceae</i>	Flaxseed (<i>Linum usitatissimum</i>)	Lin u 1		
<i>Brassicaceae</i>	Yellow mustard (<i>Sinapis alba</i>)	Sin a 1		Sin a 2
	Indian mustard (<i>Brassica juncea</i>)	Bra j 1		
	Rapeseed (<i>Brassica napus</i>)	Bra n 1		
	Field mustard (<i>Brassica rapa</i>)	Bra r 1		
<i>Rutaceae</i>	Sichuan pepper (<i>Zanthoxylum bungeanum</i>)	Zan b 1		
<i>Actinidaceae</i>	Kiwi fruit (<i>Actinidia deliciosa</i>)	Act d 13		Act d 12
<i>Cucurbitaceae</i>	Pumpkin (<i>Cucurbita maxima</i>)	Cuc ma 5		Cuc ma 4
<i>Polygonaceae</i>	Common buckwheat (<i>Fagopyrum esculentum</i>)	Fag e 2	Fag e 3, Fag e 5	
	Tartarian buckwheat (<i>Fagopyrum tataricum</i>)	Fag t 2		
<i>Euphorbiaceae</i>	Castor bean (<i>Ricinus communis</i>)	Ric c 1, Ric c 3		

bonds.¹⁵³⁶ Some of these peptides, such as those derived from Ara h 1 and Jug r 2, bind IgE from a considerable fraction of patients allergic to peanut or walnut, respectively.¹⁵³⁷ Strikingly, IgE from a subpopulation of these allergic patients does not even bind the respective mature vicilin. Hence, these peptides constitute important allergens distinct from mature vicilins.

7S globulin family characteristics

- Trimeric glycoproteins composed of subunits folding into two β -barrels surrounded by α -helical loops
- Moderately conserved sequences
- Trimers of about 150 kDa in size but also containing differently processed molecular forms
- Stable against heat and digestion
- Present in seeds of dicotyledonous plants

11S globulins

11S globulins (legumins) are the most abundant seed storage proteins comprising up to 50% of the total protein in some species. Legumins with allergenic properties are Ara h 3 from peanut, Gly m 6 from soybean and Cor a 9 from hazelnut (Table 94). Legumin subunits are 50-60 kDa in size and are composed of a 30-40 kDa acidic chain and a 20 kDa basic chain connected by a conserved disulfide bond (Table 95; Figure 174C). These subunits adopt a fold similar to that of vicilins composed of two cupin β -barrels surrounded by surface-exposed α -helical and unstructured stretches (Figure 175D). Legumins form hexamers of 300-450 kDa in size composed of two trimers one stacked on top of the other (Figure 175E,F). Sequences of legumins are more conserved than those of other storage proteins, with typically 40-60% sequence identity between homologues from nonrelated plants (Table 98). In addition, legumins show considerable sequence similarities with the structurally related vicilins.

FIGURE 174 Typical post-translational processing of seed storage proteins. A. 2S albumins; B. 7S globulins; C. 11S globulins

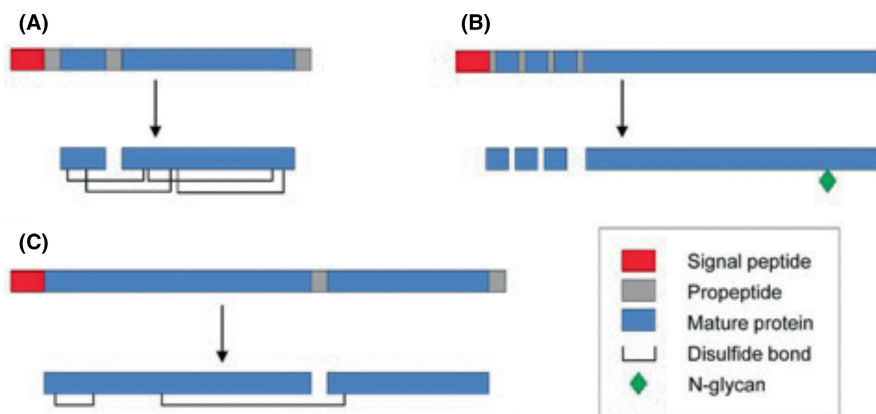


TABLE 95 Basic protein characteristics of seed storage proteins

Protein characteristics	2S albumins	7S globulins	11S globulins
Allergen source	Legumes, nuts, seeds	Legumes, nuts, seeds	Legumes, nuts, seeds
Molecular structure	α -helical bundle of 4-5 helices; mostly composed of 2 disulfide-linked chains	2 β -barrels surrounded by α -helical and unstructured loops	2 β -barrels surrounded by α -helical and unstructured loops; composed of 2 disulfide-linked chains
Theoretical molecular weight	11-18 kDa; small chain: 3-5 kDa; large chain: 8-10 kDa	45-60 kDa	50-61 kDa; acidic chain: 29-40 kDa; basic chain: 19-22 kDa
Length	90-151 aa; small chain: 26-43 aa; large chain: 64-92 aa	400-522 aa	438-531 aa; acidic chain: 256-347 aa; basic chain: 172-192 aa
Ligand binding	No	No	Metal ions, e.g. Mg^{2+}
Oligomerization	No	Trimers	Hexamers
Glycosylation	No	Yes	No
Disulfide bonds	4-5	No	2
Isoelectric point	4.5-7.5; small chain: 5.4-10.1; large chain: 4.6-7.0; Brassicaceae: 9.4-10.8; small chain: 10.3-10.9; large chain: 9.1-9.5	4.9-7.3	5.6-7.3; acidic chain: 4.9-6.0; basic chain: 6.1-10.6
Synthesis	In seeds after fertilisation until maturation	In seeds after fertilisation until maturation	In seeds after fertilisation until maturation
Distribution	In seeds of gymnosperms and dicotyledonous plants	In seeds of mono- and dicotyledonous plants	In seeds of mono- and dicotyledonous plants

11S globulins family characteristics

- Hexameric proteins composed of subunits folding into two β -barrels surrounded by α -helices and unstructured loops
- Moderately conserved sequences
- Hexamers of 300-450 kDa in size
- Stable against heat and digestion
- Highly abundant in seeds of dicotyledonous plants

Heterogeneity of seed storage proteins

Seed storage proteins purified from their natural sources are heterogeneous mixtures of similar proteins, which presents a challenge for their exact characterization and the production of natural-like recombinant allergens. Several mechanisms contribute to this heterogeneity:

- Isoforms: Many storage proteins are expressed as mixtures of distinct isoforms that differ mainly in their surface-exposed regions and therefore may also have different IgE-binding properties.

TABLE 97 Amino acid sequence identities (%) between allergenic 7S globulins. Light blue: identities from 35% to 49%, blue: identities from 50% to 74%, dark blue: identities ≥ 75%. Sequence alignments were performed using ClustalX.

Jug r 2																	
Car i 2	93																
Mac i 1	48	48															
Jug r 6	47	46	44														
Cor a 11	51	50	46	81													
Ana o 1	40	37	42	59	57												
Pis v 3	42	38	44	61	61	81											
Ses i 3	48	46	46	59	59	51	54										
Pin k 2	38	38	38	39	38	37	38	39									
Gly m 5	38	37	38	34	34	30	33	35	31								
Vig r 2	37	37	37	34	33	29	30	32	32	71							
Lup an 1	41	39	36	34	36	28	30	33	33	59	56						
Pis s 1	40	40	40	38	40	35	35	34	33	59	56	58					
Pis s 2	40	37	37	37	39	31	31	32	32	55	52	50	69				
Ara h 1	39	37	36	33	35	29	30	32	29	53	49	49	53	48			
	Jug r 2	Car i 2	Mac i 1	Jug r 6	Cor a 11	Ana o 1	Pis v 3	Ses i 3	Pin k 2	Gly m 5	Vig r 2	Lup an 1	Pis s 1	Pis s 2	Ara h 1		

TABLE 98 Amino acid sequence identities (%) between allergenic 11S globulins. Light blue: identities from 35% to 49%, blue: identities from 50% to 74%, dark blue: identities ≥ 75%. Sequence alignments were performed using ClustalX.

Ses i 6																	
Sin a 2	38																
Pru du 6	43	46															
Ses i 7	41	44	47														
Cuc ma 4	39	39	44	49													
Pis v 2	41	44	47	50	50												
Ber e 2	40	41	46	51	45	48											
Act d 12	46	45	52	53	48	51	64										
Jug r 4	45	47	56	54	50	51	54	56									
Car i 4	45	46	55	54	50	53	54	55	95								
Cor a 9	43	48	56	52	48	49	53	55	76	75							
Ana o 2	43	48	50	53	49	52	51	54	62	62	59						
Pis v 5	42	49	50	50	47	52	49	54	61	61	59	80					
Ara h 3	38	35	42	40	40	40	39	42	47	47	47	48	48				
Gly m 6	35	40	43	41	39	41	41	43	50	48	48	50	50	63			
	Ses i 6	Sin a 2	Pru du 6	Ses i 7	Cuc ma 4	Pis v 2	Ber e 2	Act d 12	Jug r 4	Car i 4	Cor a 9	Ana o 2	Pis v 5	Ara h 3	Gly m 6		

- Post-translational proteolytic processing: The proteolytic processing described above for all three families further increases the heterogeneity as cleavage may occur at different positions leading to differentially truncated forms of the proteins.
- Glycosylation: Most vicilins harbor a single N-linked glycan. Hence, the existence of different glycoforms adds an additional layer of complexity.

Biochemical and physico-chemical properties

The distinct properties of seed storage proteins explain many of their allergological features

- Abundance: Seeds contain between 10% (cereal grains) and 40% (some legumes and oilseeds) protein; the major part of it is composed of storage proteins.¹⁵³⁵ As a consequence, even minute amounts of seeds contain sufficient quantities of storage proteins to elicit allergic reactions in some highly sensitized individuals. In placebo-controlled oral provocation studies, some patients reacted to as little as 0.1 mg of peanut flour or 0.5 mg of lupine flour.¹⁵³⁸ Small amounts of these proteins are also found as impurities in processed foods. These “hidden” allergens pose a risk to allergic individuals, who may react with dangerously severe symptoms.

- **Stability:** Seed storage proteins, especially 2S albumins, are highly stable against food processing and gastro-intestinal digestion.¹⁵³⁹ For instance, it has been shown that roasting of peanuts increased the IgE-binding capacity and stability of the allergens, partially due to covalent cross-linking during the Maillard reaction, which leads to the formation of stable molecular aggregates. This explains why patients sensitized to seed storage proteins usually also react to processed foods, such as roasted peanuts or tree nuts or peanut butter. Their stability against digestive enzymes enables allergenic storage proteins to reach the small intestine and the circulation, thereby causing severe systemic allergic reactions.

3 – Clinical relevance

Sensitization to these three allergen families (2S albumins, 7S globulins and 11S globulins) is generally associated with a high risk to develop an allergic reaction upon ingestion. Allergic symptoms, which are elicited by IgE binding to those allergens, can reach from mild (e.g., oral itching) to life-threatening conditions such as anaphylaxis.

2S albumins

The extraordinary stable structure of 2S albumins is thought to contribute to its allergenicity and clinical relevance. The measurement of IgE specific to 2S albumins is mostly superior to measuring IgE against total extracts in edible seed allergy diagnosis. In peanut allergy, approximately 90% of patients sensitized to Ara h 2 suffer from a (severe) peanut allergy, while only 70% of patients with IgE to peanut extract are truly allergic.¹⁵⁴⁰ A comparable clinical importance was described for the other two peanut 2S albumins Ara h 6 and 7.¹⁵⁴⁰ Consistently, IgE binding to tree nut 2S albumins is also associated with clinically relevant sensitization: hazelnut Cor a 14, cashew nut Ana o 3, Brazil nut Ber e 1 and walnut Jug r 1.^{1541,1542} However, it was shown that IgE to Jug r 1 is not significantly more relevant than measuring IgE to walnut extract in adults. 2S albumins are also predominantly recognized by IgE from patients with seed (e.g., sesame Ses i 1) or legume (e.g., soy Gly m 8) allergies.^{1543,1544}

7S globulins

In tree nut allergy, 7S globulins are clinically less relevant compared with 2S albumins. For example, recognition of the hazelnut 7S globulin Cor a 11 by adults is extremely rare and its clinical relevance is not confirmed.⁴⁴ By contrast, the role of 7S globulins appears to be more important in legume allergies. In soybean allergy, 86% of patients with anaphylaxis were sensitized to Gly m 5, while only 33% of patients with subjective symptoms showed IgE to this 7S globulin.¹⁵⁴³ This clear association between sensitization to soybean Gly m 5 and severe symptoms was only confirmed in paediatric populations. Moreover, 7S globulins were also characterized as major allergens (>50% *in vitro* recognition) in other legumes such as lupine, lentil, pea and chickpea. The lentil 7S globulin Len c 1.01 was recognized by 77% of lentil allergic patients, and 65% of IgE binding

to lentil extract was inhibited by preincubation with Len c 1.01.¹⁵⁴⁵ Despite their extensive recognition by IgE, the exact clinical relevance of 7S globulins in legume allergy needs still to be determined.

11S globulins

The clinical relevance of IgE binding to 11S globulins differs between foods and cannot be assigned to a specific group. While IgE binding to peanut Ara h 3 is less relevant than IgE to Ara h 2 (2S albumin), IgE binding to the hazelnut 11S globulin Cor a 9 has a comparable diagnostic value compared with IgE to the hazelnut 2S albumin Cor a 14.⁴³ IgE to both allergens is associated with severe symptoms in children. In adults, however, this clear association between IgE binding and allergy or objective symptoms was not found.¹⁵⁴⁴ In walnut allergy, only a small subpopulation of walnut allergic adults recognizes the walnut 11S globulin Jug r 4.¹⁵⁴¹ and in cashew nut allergic children, the diagnostic value of IgE to Ana o 2 is comparable to the diagnostic value of IgE to the 2S albumin Ana o 3.¹⁵⁴¹ In almond allergy, IgE binding to the almond 11S globulin Pru du 6 shows a high sensitivity (83%) and specificity (78%), which is superior to measuring IgE against almond extract or other almond components.¹⁵⁴⁷ Strikingly, 2S albumins and 7S globulins—important allergens for other tree nuts—appear to be absent in almond kernels, which makes Pru du 6 an even more important component than 11S globulin in other tree nuts, legumes, and seeds. Although sesame seeds can cause severe allergic reactions, information regarding clinical relevance of IgE to 11S globulins is lacking. Nevertheless, it has been shown that Italian children allergic to sesame strongly recognized the basic subunit of the 11S globulin, which is only accessible after proteolytic cleavage of the acidic subunit.¹⁵⁴⁸

Clinical relevance of 2S albumins

- Major allergens in peanut and tree nuts such as hazelnut, walnut and cashew nut
- Marker allergens for clinically relevant sensitizations to peanut, seeds and tree nuts
- High risk of cross-reactivity between walnut and pecan nut or cashew nut and pistachio
- IgE to these allergens may elicit severe symptoms

Clinical relevance of 7S globulins (vicilins)

- Major allergens of legumes such as soy, pea, lentil and lupine
- Marker allergens for clinically relevant sensitizations to legumes
- Risk of cross-reactivity between peanuts and peas or lupine
- Risk of cross-reactivity between peas and lentils

Clinical relevance of 11S globulins (legumins)

- Major allergens in hazelnut and almond
- Marker allergens for clinically relevant sensitizations to almonds, hazelnuts and peanuts
- IgE to these allergens may elicit severe symptoms

Age-related sensitization patterns

Sensitizations to seed storage proteins are biomarkers for a clinically relevant edible seed allergy in children. For example, IgE to Ara h 2 ≥ 5 kU/l can classify Dutch children as peanut allergic.¹⁵⁴⁹ Additionally, the absence of IgE to Ara h 2 can be used to rule out primary peanut allergy. Such advantageous use of IgE measurements to seed storage proteins (Cor a 9 and 14) was also shown for hazelnut allergy in children suffering from objective symptoms.⁴³ Furthermore, younger children are mostly sensitized to the walnut seed storage proteins Jug r 1 and 4, and their allergies have been shown to be more severe than walnut allergies in older children and adults.¹⁵⁵⁰ By contrast, sensitization patterns of adults, especially in birch-endemic regions (Northern and Central Europe), are more complex due to increased sensitization to the birch pollen PR-10 protein, Bet v 1, and its homologues. So far, this effect has been shown for peanut, hazelnut, and walnut allergies.^{43,1549,1550} Hence, the absence of IgE binding to seed storage proteins does not necessarily exclude a peanut or tree nut allergy in adults. Nevertheless, PR-10 protein-related allergies are usually less severe.¹⁵⁴⁴

Geographical differences

The sensitizing allergens in edible seed allergies differ geographically. nsLTP-related food allergies—due to sensitization to, e.g., peanut Ara h 9—are more common in the Mediterranean area, where peanut/tree nut allergies often go along with peach allergy.

However, it was shown that younger peanut allergic children in Spain were predominately sensitized to Ara h 2, while sensitization to Ara h 9 predominated over sensitization to Ara h 2 in older children.¹⁵⁵¹ Nevertheless, seed storage proteins such as Ara h 2 seem to be more important in the clinical setting in the Northern hemisphere.¹⁵⁴⁹

Cross-reactivity

Although extensive *in vitro* co-sensitization has been shown between homologous seed storage proteins in legumes, tree nuts and seeds, only a small number of such co-sensitization results in clinically relevant co-allergies between tree nuts and peanut. Hence, *in vitro* cross-reactivity does not necessarily imply clinically relevant cross-reactivity. Nevertheless, strong clinically relevant cross-reactivity was described between walnut and pecan nut and between cashew nut and pistachio with walnut and cashew nut as respective primary sensitizers.¹²⁶⁰

Although extensive research has been performed to evaluate *in vitro* and *in vivo* cross-reactivity, several cross-reactivities and potential risks might not have been identified yet. In particular, information on molecular *in vitro* and *in vivo* cross-reactivity of IgE to sesame seed components is lacking despite their known clinical relevance. Moreover, the exact underlying allergens responsible for certain cross-reactions have often not yet been identified.

Cross-reactivity between 2S albumins

Cross-reactivity between walnut and pecan nut as well as between cashew nut and pistachio can be potentially explained by cross-reactive IgE against the respective 2S albumins. Moreover, IgE to 2S albumins plays a role in clinically relevant cross-reactivity between walnut and hazelnut (Figure 176). Although *in vitro* cross-reactivity has also been shown between peanut Ara h 2 and 2S albumins from lupine (δ -conglutin), Brazil nut Ber e 1 and kiwi seeds, its clinical relevance is still a matter of debate. By contrast, negligible *in vitro* cross-reactivity was shown for IgE to hazelnut Cor a 14 and peanut Ara h 2.^{43,1544}

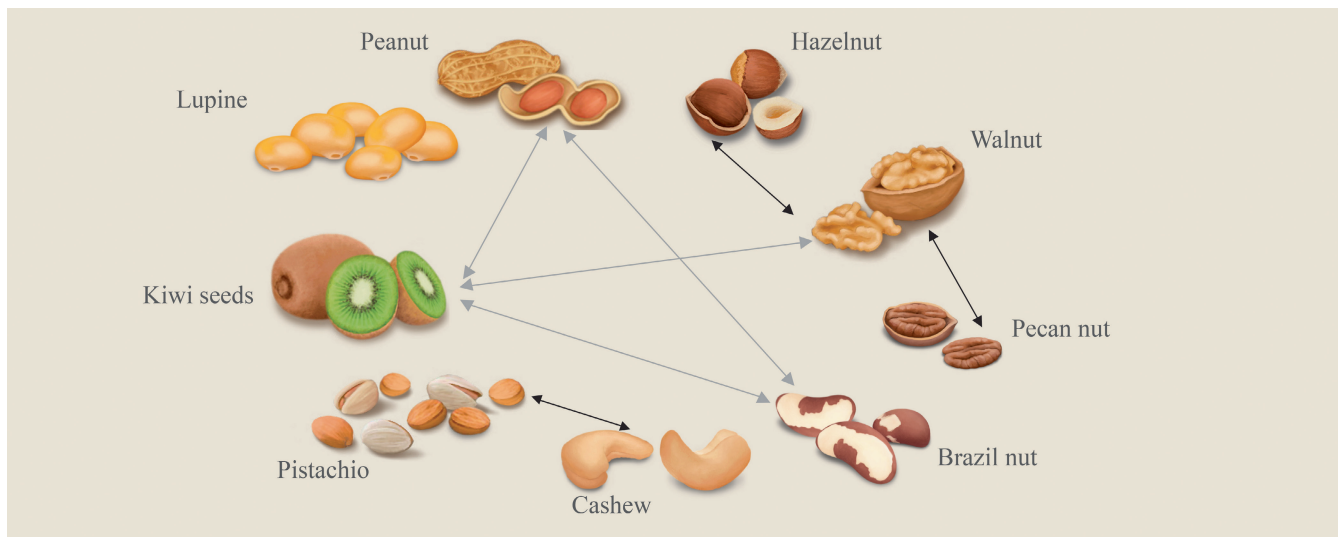


FIGURE 176 *In vitro* cross-reactivity between 2S albumins from tree nuts and legumes. Strong cross-reactivity has been shown for walnut and pecan nut, cashew and pistachio, and for hazelnut and walnut. Cross-reactivity only confirmed *in vitro* and limited knowledge regarding clinical relevance is indicated with a grey arrow.

Cross-reactivity between 7S globulins

Although evidence of (*in vitro*) cross-reactivity between tree nut 7S globulins is limited, walnut Jug r 6 displays remarkable *in vitro* cross-reactivity with 7S globulins from hazelnut (Cor a 11), pistachio (Pis v 3) and sesame seed (Ses i 3), which is in contrast to characteristics of IgE to the walnut 7S globulin Jug r 2. Additionally, cross-reactive IgE was also shown for 7S globulins from cashew nut and pistachio.¹⁵⁴⁴ By contrast, cross-reactive IgE to 7S globulins from legumes seem to play a greater role. Patients anaphylactic to pea often suffer from peanut allergy, which can be explained by cross-reactive IgE between pea Pis s 1 and peanut Ara h 1. Comparable cross-reactivity seems also to be present in peanut and lupine allergic patients with IgE to peanut Ara h 1 and lupine β -conglutin. Moreover, IgE binding to pea Pis s 1 was shown to be completely cross-reactive with lentil Len c 1 *in vitro* without confirmed clinical relevance so far (Figure 177).

Cross-reactivity between 11S globulins

Limited knowledge is available regarding (*in vitro*) cross-reactivity between 11S globulins from tree nuts, legumes and seeds. Nevertheless, one study showed that IgE to the 11S globulins from hazelnut (Cor a 9) and walnut (Jug r 4) cross-reacted in hazelnut and walnut allergic patients.¹⁵⁵² Moreover, a certain degree of cross-reactivity was shown between hazelnut Cor a 9 and peanut Ara h 3, while Ara h 3 seems to play no role in cross-reactivity between peanut and lupine.¹⁵⁴³ Another cross-reactive 11S globulin seems to be the yellow mustard Sin a 2 with confirmed *in vitro* cross-reactivity to 11S globulins of peanut and the tree nuts almond, hazelnut, pistachio and walnut (Figure 178).¹²⁵⁹

Cross-reactivity between nonhomologous seed storage proteins

Clinically relevant cross-reactivity has been commonly reported between members of the same family. Recently, several lines of evidence demonstrated that IgE cross-reactivity also exists between

members of different protein families of seed storage proteins and can also occur between seed storage proteins and some cow's milk allergens.¹⁵⁵³ It was demonstrated that IgE cross-reactive to peanut allergens Ara h 1 (vicilin), Ara h 3 (legumin) and Ara h 2 (2S albumin) comprised the major fraction of IgE specific to these allergens.¹⁵⁵⁴ The molecular basis of this cross-reactivity is the presence of highly similar amino acid sequence stretches present on surface-exposed loops. The analysis of antibodies produced by B cells from peanut allergic patients confirmed the presence of the IgE antibodies with high affinity and cross-reactivity to the three major peanut allergens.¹⁵⁵⁵

In addition, cross-reactivity was demonstrated between Ara h 2, almond legumin (Pru du 6), and walnut vicilins (Jug r 2) as well as between non homologous allergens from peanut and lupine.¹⁵⁵³ Future studies will have to address whether the occurrence of such cross-reactive antibodies accounts for the clinically observed co-reactivity to peanut, diverse tree nuts and other seeds.

Similarly, it was shown that IgE cross-reactivity also exists between non related bovine caseins, soy vicilin Gly m 5 and soy legumin Gly m 6 (summarized in¹⁵⁵³). This unexpected cross-reactivity could explain occasionally observed incidents of allergic reaction to a soy protein formula in cow's milk allergic patients, primarily not sensitized to soy.

4 – Clinical management

History

The diagnosis of food allergy always starts with a careful history of the symptoms and the foods that cause the symptoms. Seed storage proteins are stable allergens towards digestion and heating and are therefore found to be associated with severe symptoms. This

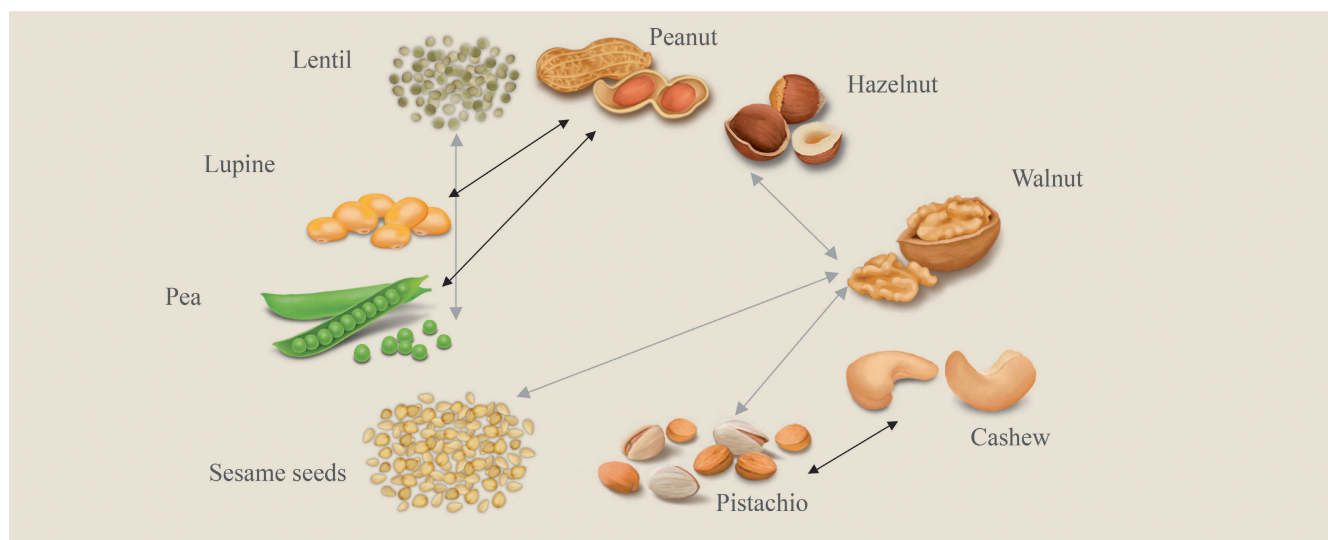


FIGURE 177 *In vitro* cross-reactivity between 7S globulins from tree nuts, seeds and legumes. Strong cross-reactivity has been shown for cashew and pistachio (black arrow). Cross-reactivity only confirmed *in vitro* and limited knowledge regarding clinical relevance is indicated with a grey arrow.

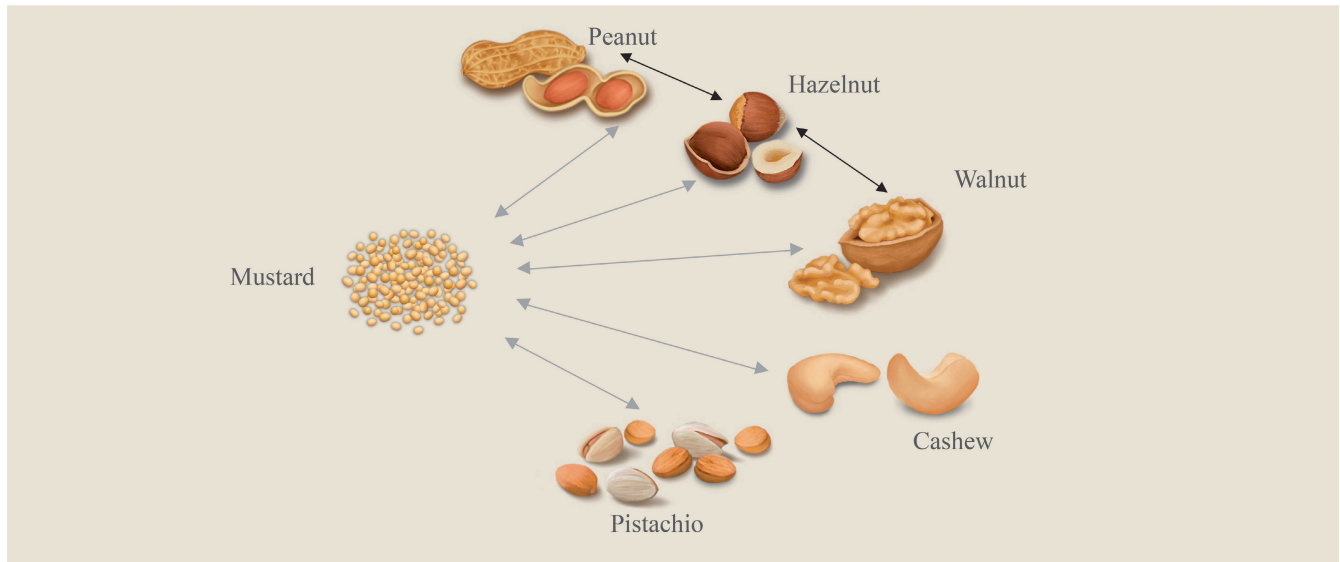


FIGURE 178 *In vitro* cross-reactivity between 11S globulins from tree nuts and seeds. Strong cross-reactivity has been shown for hazelnut and walnut (black arrow). Cross-reactivity only confirmed *in vitro* and limited knowledge regarding clinical relevance is indicated with a grey arrow.

is in contrast to (secondary) sensitization to pollen-related PR10-proteins and profilins, which are labile proteins and are associated with mild to moderate (usually oropharyngeal) symptoms.

Diagnostic value of IgE measurements to seed storage proteins

Skin prick test or allergen specific IgE to whole extracts will confirm sensitization to the respective food. In order to define the primary allergen source (Figure 179), measurement of specific IgE to components can be performed. Not all seed storage proteins are available for routine testing. In the ImmunoCAP Specific IgE test single and multiplex assays (Thermo Fisher Scientific), the following seed storage proteins are currently available for routine *in vitro* diagnostics: peanut rAra h 1, rAra h 2, rAra h 3, rAra h 6, soy nGly m 5, nGly m 6, hazelnut nCor a 9, rCor a 14, cashew nut rAna o 2, rAna o 3, walnut rJug r 1, nJug r 2, Brazil nut rBer e 1, sesame nSes i 1 and buckwheat nFag e 2.

Several studies demonstrated that seed storage proteins play an important role in the diagnosis of peanut, tree nut and seed allergy. They can support the diagnosis of food allergy, but may also give an indication on the severity of the food allergy. For peanut, it was shown that IgE to Ara h 2 has a better diagnostic accuracy than IgE to peanut extract. Cut-off values for Ara h 2 were defined with positive predictive values (PPV) of up to 100% for diagnosis of peanut allergy.¹⁵⁴⁰ However, one should keep in mind that PPVs depend on the population, setting and geographic location. Measurement of IgE to Ara h 1, 3 and 6 appears less useful in the diagnosis of peanut allergy when IgE to Ara h 2 is already confirmed. However, one study showed that measurement of Ara h 6 could be useful, because co-sensitization to Ara h 2 and Ara h 6 appeared to be associated with severe reactions distinguishing severe allergy from mild symptoms. IgE to hazelnut Cor a 9 and 14 was found to be predictive for clinical reactivity to hazelnut and both were associated with severe reactions.¹⁵⁴⁴ IgE to walnut Jug r 1 was found to be superior to IgE

to walnut extract in the diagnosis of walnut allergy in children but appeared not to have an additional value in the diagnosis of walnut allergy in adults. IgE to cashew nut Ana o 3 was highly predictive for cashew nut allergy and discriminated between allergic and tolerant children better than cashew nut extract specific IgE; a cut off was found with 95% PPV for diagnosing cashew nut allergy.^{1544,1556} The diagnostic value of Ses i 1 appeared to be better than IgE to sesame extract, to Ses i 2 and to 7S and 11S globulins of sesame.¹²⁶⁴ In conclusion, IgE to seed storage proteins has generally a high predictive value to diagnose an allergy to the respective food, has a higher diagnostic value than measurement of IgE to whole extracts, and for some foods, IgE to these allergens is associated with severe clinical reactions. Therefore, measurement of IgE to seed storage proteins is a useful tool in the diagnosis of peanut, tree nut and seed allergy.

Clinical relevance of cross-sensitizations

Cross-sensitization within and between legumes, tree nuts and seeds exists, but clinical relevance of these cross-sensitizations varies and may differ between different geographic regions. With regard to legumes, cross-sensitization of peanut allergic patients with other legumes occurs frequently but mostly does not demonstrate clinical allergy.^{1067,1538,1552} Lupine may be the most clinically relevant peanut cross-reactive legume, showing sensitization rates of 34-88% and clinically manifested allergy in 4-88% of peanut allergic patients. In peanut allergic patients, sensitization to soybean occurs frequently (31-58%), while clinical allergy to soybean only ranged from 3% to 15%.

Conversely, one study showed that 88% of soybean allergic patients were also peanut allergic. Co-allergies to other legumes (e.g., lentil, chickpea, and pea) in peanut allergic patients have been reported but are less common, especially for beans. Between other legumes, a high degree of IgE cross-reactivity was demonstrated among lentils, chickpeas and peas. Food challenges confirmed that

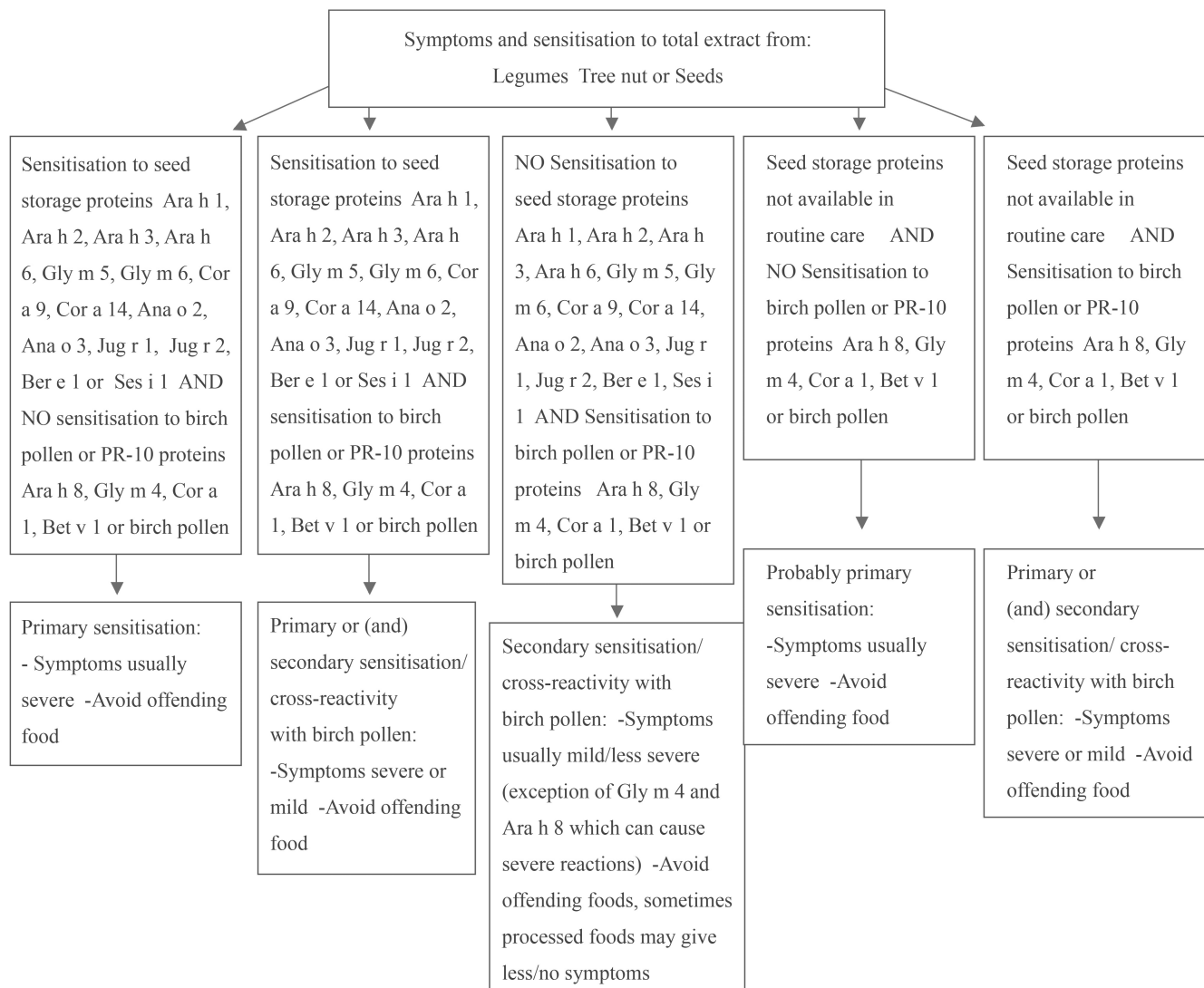


FIGURE 179 Distinction of primary and secondary sensitization for legumes, tree nuts, and seeds with molecular allergy diagnostics in routine care

clinical allergy to all three legumes was frequently found in a Spanish cohort.^{1538,1552,1553}

Peanut and tree nut allergy often co-exists in one patient. Although homology between allergenic proteins of these foods has been demonstrated, the co-allergy between peanut and tree nuts is probably not primarily due to cross-reactivity of IgE to peanut and tree nut allergens.¹⁵⁵⁴ Taxonomically, peanut and tree nuts are from very different plant groups. Patients in whom co-allergy between peanut and tree nuts exists are likely sensitized to peanut and tree nuts independently. Regarding cross-reactivity of PR-10 proteins, one study showed a high correlation between sensitization to Cor a 1 and Ara h 8, which might indicate that cross-reactivity of PR-10 proteins is a major cause of hazelnut/peanut co-sensitization.¹⁵⁵⁵

Regarding co-allergies between tree nuts, The NUT CRACKER study demonstrated that whilst most patients were sensitized to

5-6 tree nuts, over 50% were only allergic to 1-2 tree-nuts. There is an especially high correlation between walnut-pecan and cashew-pistachio allergies. No association between almond and other tree nuts was found in the NUT CRACKER study. Besides cross-reactivity to seed storage proteins, tree nuts can also show cross-reactivity with pollen, resulting in pollen food allergy syndrome, which is related to milder (usually oropharyngeal) symptoms (Figure 179).

In conclusion, it has to be emphasized that IgE cross-reactivity does not mean that there is also clinically relevant co-allergy. Diagnosis of a legume or tree nut allergy does not automatically imply that all legumes or tree nuts have to be avoided. The oral food challenge is still the gold standard to confirm food allergy and to investigate whether a found co-sensitization is relevant or not.

Management

Patients with a food allergy to legumes, tree nuts or seeds, especially the ones that are sensitized to seed storage proteins

should avoid the offending food. Furthermore, patients should receive a treatment plan in case of accidental allergic reactions. Patients with severe reactions should receive an adrenaline auto-injector, including a training in how and when to use it as well as an allergy pass.

5 – Clinical cases

Case #1

Clinical history: A 21-year old man always developed symptoms of tightness of the throat, urticaria, wheezing and dyspnea after ingestion of peanut. The same symptoms developed after ingestion of green pea and lentil. Beans and products with lupine were ingested without symptoms. He avoided soy his whole life, so it is unknown if that caused symptoms. No symptoms of allergic rhinitis.

Tests with extracts: Skin prick test positive for peanut and soybean. Specific IgE to peanut > 100 kU/l, soy 11.5 kU/l, green pea 8.8 kU/l, lentil 6.5 kU/l.

Tests with molecules: Ara h 2 79.8 kU/l

Oral food challenges: Food challenge with soy was positive at a dose of 0.03 gram soy protein with symptoms of tightness of the throat and urticaria.

Diagnosis: Primary peanut allergy with co-allergy to soybean, lentil and green pea. No allergy to lupine or beans.

Case #2

Clinical history: A 10-year old girl had symptoms upon ingestion of a nut mix with walnut, hazelnut, almond and cashew nut consisting of oral allergy symptoms, erythema, nausea and dyspnea. She also had allergic rhinitis. She has never eaten nuts before.

Test with extracts: Skin prick test was positive for walnut, hazelnut and birch, negative for almond and cashew nut. Specific IgE to walnut was 2.09 kU/l, hazelnut 9.4 kU/l, almond 0.06 kU/l, cashew nut 0.00 kU/l.

Test with molecules: Multiplex assay ISAC: Walnut Jug r 1 3.4 ISU, hazelnut Cor a 1 1.04 8.7 ISU. Negative for hazelnut Cor a 9, negative for Ana o 2.

Singleplex assay: Cor a 14 2.00 kU/l, Cor a 1 12.1 kU/l

Oral food challenges: Oral food challenge with hazelnut was positive, symptoms consisted of oral allergy symptoms, tightness of the throat, nausea, vomiting and erythema.

Oral food challenge with walnut was also positive, symptoms consisted of oral allergy symptoms, erythema and dyspnea. Almond and cashew nut were introduced at home without any problem.

Conclusion: A primary food allergy to hazelnut and walnut, with in addition also a pollen-related food allergy to hazelnut. Because of high correlation between walnut and pecan nut allergy, also pecan nut has to be avoided. No allergy to almond, no allergy to cashew nut.

C09 – Gibberellin-regulated proteins

Pascal Poncet, Tomona Iizuka, H el ene S en echal,
Enrico Scala

Highlights

- Gibberellin-regulated proteins (GRPs) are small, cationic, nonglycosylated monomeric proteins with anti-microbial activity, present in plant foods and pollen.
- GRPs are resistant to heat and proteolysis.
- GRPs are cross-reactive and involved in Pollen Food Allergy Syndromes.
- Main fruits involved: peach and citrus but also apricot, cherry, or pomegranate.
- Cupressaceae is, up to now, the only tree family shown to express allergenic pollen GRP.
- GRPs may induce severe systemic reaction with or without cofactors.

1 – The protein

The very first Gibberellin-Regulated Protein (GRP) allergen was described in 2013 in peach (*Prunus persica*) and was named Pru p 7 (formerly peamaclein).¹⁵⁵⁹ The sensitization was reported in peach allergic patients negative for the other allergens known in peach, especially the nsLTP Pru p 3 that shares some characteristics with Pru p 7, i.e., low molecular weight (MW) and basic isoelectric point (pI). The characterization was refined and confirmed in 2014.¹⁵⁶¹ Pru p 7 is a nonglycosylated, cationic, monomeric protein with an MW around 7–8 kDa and a pI around 9. It belongs to the cysteine-rich plant antimicrobial peptide families that are involved in plant growth and resistance to bacteria, viruses, or other microorganisms that can cause plant disease.¹⁵⁶² Twelve cysteines involved in 6 disulfide bridges confer the protein stability and resistance to heat and proteolysis.

GRP characteristics

- 6 well-conserved disulfide bridges
- Expressed in pulp and peel of plant food
- Protein present but not synthesized in pollen grain
- Plant defence protein
- The structure displays a cleft likely to bind an unknown ligand
- Pollen/food cross-reactive

2 – The family

The family name GRP is now well accepted in the field of allergy although it may not be the most appropriate since the allergens,

with the associated number 7, rather belong to the Snakin/GASA (Gibberellic Acid Stimulated in Arabidopsis) protein family, a sub-family of GRP. Indeed the phytohormone gibberellin regulates very diverse proteins in plants, nonallergenic ones as well as allergenic such as, besides snakin/GASA proteins, superoxide dismutase, β -1,3-glucanase, calmodulin or oleosin.¹⁵⁶³

Gibberellin is a phytohormone produced by all plants, some fungi and bacteria. It corresponds to a family of tetracyclic diterpenic molecules playing a role in plant growth and breaking dormancy.¹⁵⁶⁴ Gibberellin and GRP have an important role in plant development, host defence and redox homeostasis. Consequently, their concentration is strictly regulated and may be different in specific developmental stages. Furthermore, both biotic and abiotic stresses could influence GRP levels.¹⁵⁶⁵ Nowadays gibberellins are widely used in modern agriculture to increase the yield and/or quality of plant food.¹⁵⁶⁶ Numerous plant foods are submitted to an exogenous gibberellin treatment such as grape, cherry, strawberry, pear, tangerine, plum, orange, blueberry, pineapple, tomato, potato, wheat, rice, barley, hop, sunflower, alfalfa (*Medicago*), chili/red pepper, zucchini, salad, spinach, celery or cotton. By consequence, the utilization of exogenous synthetic gibberellin might affect the concentration of GRPs synthesized in plant foods and even in pollens, therefore influencing also their allergenic potency.

Once produced, GRPs contain a signal peptide of 25 amino-acid that is subsequently removed to obtain the protein mature form of 7 kDa (63 AA). Mature GRPs are structurally characterized by a highly conserved C-terminal region and, as in Pru p 7, by the 12 cysteines at conserved positions. GRPs are water-soluble proteins positively charged at neutral pH with a compact globular conformation, which may result in over-evaluation of its MW depending on the bio- and physicochemical analytical methods used. The protein folding is responsible for conformational epitopes destroyed upon *in vitro* reduction in disulfide bonds.

Snakin-1, the first GRP described in 1999, was isolated from *Solanum tuberosum* from the potato plant tuber allowing extensive studies on its structure and antimicrobial activity.¹⁵⁶⁵ The three-dimensional structure of snakin-1 was obtained by X-ray crystallography.¹⁵⁶⁷ The folding of the protein comprises three alpha-helices and a cleft likely able to accommodate one or more ligands, as yet undetermined (Figure 180).

Snakin-1 is not yet described as an allergen. After the description of Pru p 7, Pru p 7 a GRP from pomegranate (*Punica granatum*) was reported¹⁵⁶⁸ as well as Pru m 7, the GRP from Japanese apricot (*Prunus mume*).¹⁵⁶⁹ In Japan, Japanese apricots are traditionally consumed marinated in salt, they are named umeboshi. More fruits were suspected to contain allergenic GRPs,¹¹³⁰ but convincing data were subsequently obtained only for orange (*Citrus sinensis*) and sweet cherry (*Prunus avium*), Cit s 7¹⁵⁷⁰ and Pru av 7, respectively (IUIS/WHO Pru av 7 descriptions: http://www.allergen.org/viewallerg_en.php?aid=1002). Grapefruit, tangerine and lemon contain cross-reactive GRP with orange (Poncet et al., unpublished results).

A breakthrough was provided by the study of allergenic GRPs when it was demonstrated that an allergen from the Cupressaceae

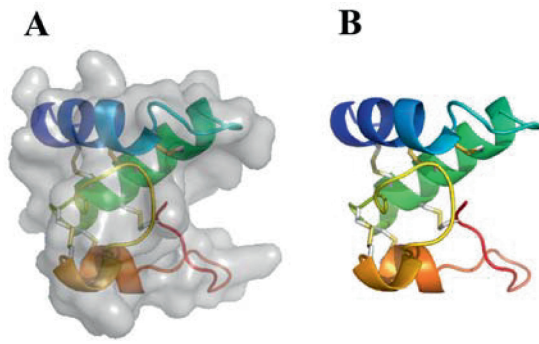


FIGURE 180 Three-dimensional structure of Snakin-1 (PDB 5E5Q). Ribbon representation with (A) or without surface (B).

pollen first reported in 2010,¹⁵⁷¹ the formerly called BP14, was shown to belong to the GRP protein family.¹⁵⁷² The pollen food associated syndrome (PFAS) between peach or citrus and cypress pollen reported in 2006¹⁵⁷³ and 2015¹⁵⁷⁴ was thus explained by the existence of an IgE cross-reactivity between Pru p 7 or Cit s 7 and the allergen BP14.^{230,1575,1576} The gene coding for BP14 was then fully sequenced from common cypress (*Cupressus sempervirens*) strobili by next-generation sequencing and the protein named Cup s 7 (IUIS/WHO Description of Cup s 7, <http://www.allergen.org/viewallergen.php?aid=997>). A homologous allergen, Cry j 7, with similar fruit cross-reactivities, was then described in Japanese cedar pollen (*Cryptomeria japonica*) by studying Japanese patients allergic to Japanese cedar pollen and food.¹⁵⁷⁸ As well the existence of a mountain cedar pollen (*Juniperus ashei*) GRP, Jun a 7, was confirmed.¹¹⁵⁷ We could expect that other trees from the Cupressaceae family such as the Japanese cypress (*Chamaecyparis obtusa*) or the bald cypress (*Taxodium distichum*) also express an allergenic pollen GRP.

Finally, in 2021, an allergenic GRP, Cap a 7, was revealed in bell pepper (*Capsicum annuum*) by studying a Japanese patient allergic to several GRPs, from bell/chili pepper (Cap a 7), from peach (Pru p 7), orange (Cit s 7) and from Japanese cedar pollen (Cry j 7) demonstrating a clinical relevance of the cross-reactivities between different GRPs (IUIS/WHO Description of Cap a 7, <http://www.allergen.org/viewallergen.php?aid=1061>).

Up to now, GRPs from only 9 allergenic sources have been described as allergens. Five from fruits, 1 from a vegetable and 3 from tree pollen, all belonging to the Cupressaceae family (Tables 99 and 100).

Cupressaceae GRPs are very similar with more than 90% sequence identity and share more than 60% sequence identity with fruit and vegetables. Similarly, the percentage of sequence identity between fruit GRPs or vegetable GRPs are high and close to each other. Therefore, all GRP should theoretically be cross-reactive (Table 101). However, the cross-reactivity is not always experimentally observed.¹⁵⁷⁸

The relationships between the different taxa and the 3-dimensional modelling of proteins are depicted in (Figure 181). The pollen GRPs are more distant from plant food-derived ones. Snakin-1 from potato and citrus fruits such as grapefruit (*Citrus*

maxima), tangerine (*Citrus reticulata*) and lemon (*Citrus limone*) are depicted on a yellow background because the GRP allergens are not fully characterized. However, GRP cross-reactivities were shown among citrus fruits and a clementine (*Citrus clementina*) GRP is described in the Uniprot KB database (accession number V4T144) with a 100% sequence identity with orange GRP.

Three-dimensional modelling using potato snakin-1 as a template showed a few structural differences between the various GRPs that could lead to variations in the size of the three epitope regions predicted by the software DiscoTope 2.0 (Figure 181).

3 – Clinical relevance

GRPs are found in both, pulp and peel of fruits, in contrast to nsLTPs, which are mainly present in the peel, and to a lower extent in the pulp. However, bell pepper GRP was only found in the pulp (unpublished results). Interestingly GRPs can be present or absent in different fruit cultivars, even in distinct lots belonging to the same cultivar.^{559,1568}

Very often the sensitization to fruit GRPs is associated with Cupressaceae pollen allergy. This was observed for Mediterranean cypress in Europe^{1576,231} as well as for Japanese cedar in Japan.¹⁵⁷⁷ Forty-six per cent of young Japanese patients allergic to Japanese cedar pollen and fruit are sensitized to GRPs. This observation suggests a possible interdependence of both sensitizations. The association might rely not only on the cross-reactivity between Cupressaceae and fruit GRPs but also on a sensitization process involving some specific ligand-protein interactions common between the two allergenic sources that synergise the allergic response towards GRPs. Interestingly, in the case of allergy to GRPs, sensitization to cypress pollen does not necessarily involve Cup a 1, the major allergen of Cupressaceae pollen. It is not known whether sensitization to GRPs from cypress (i.e., Cup s 7 or Cry j 7), in the absence of recognition of Cup a 1, can generate respiratory symptoms or not. At the same time, it is not known whether sensitization to food GRPs necessarily follows a sensitization to pollen (as in the case of PR-10 or Profilin; (chapters C01, C02) or can be directly caused by fruits, acting as primary sensitizers (as for nsLTPs, in the Mediterranean area). The main fruits involved are peach and citrus. Pomegranate allergy seems much rarer and the only patient allergic to bell/chili pepper was also allergic to Japanese cedar pollen, peach and citrus (see clinical case #4). GRP cross-reactivities that are immunochemically assessed using recombinant protein may not be clinically relevant. This was observed with snakin-1 able to be bound by IgEs from a cypress/peach allergic patient (Cup s 7+/ Pru p 7+) but unable to activate the patient's basophils in agreement with the tolerance of potato consumption by the patient.²³⁰ Differences in antibody affinity probably play a role. At least two pollen food allergy syndromes were previously described between cypress pollen and peach and/or citrus.^{1573,1574} GRPs should be clinically relevant since they can induce *ex-vivo* basophil activation.^{230,231,559} GRP allergies were reported to be more common in adolescents

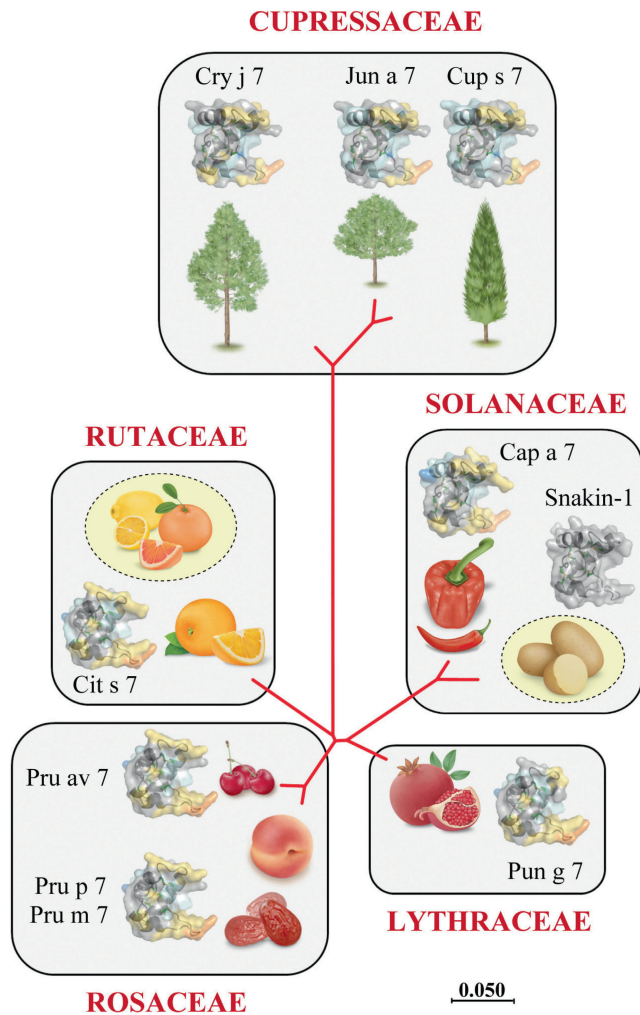


FIGURE 181 Evolutionary relationships of taxa (phylogenetic tree) and 3D modelling of nine allergenic GRP and the prototype reference GRP snakin-1 from potato. The evolutionary history was inferred using the Neighbor-Joining method¹⁵⁷⁹ and evolutionary analyses were conducted in MEGA X¹⁵⁸⁰. Three-dimensional structure modelling of proteins was calculated using snakin-1 as a template. Three conformational epitopic regions were predicted using the software Disco Tope 2.0. They are coloured in yellow and orange.

extracts showed identical performances, while in the case of labile allergen (Pru p 1 or Pru p 4) reactivities, they consistently gave a negative result. This extract evaluation is therefore an excellent approach to identify reactivity to nsLTP or, possibly Pru p 7, during the first screening of the patient.¹⁵⁸³

In another multicenter Italian study, 835 cypress pollen hypersensitive patients were evaluated with a peach extract containing Pru p 7 by SPT. In peach sensitized individuals, IgE to rPru p 3 was evaluated, and only those scoring negative were further studied for IgE reactivity to rPru p 7 by immunoblot and by an, at that time, “experimental” ImmunoCAP Specific IgE test with rPru p 7. Peach SPT reactivity was found in 163 (19.5%) patients, but 127 (77.9%) were excluded because they were also Pru p 3 reactors. On immunoblot, only 3/18 subjects recognized a band at about 7 kDa. Ten/18 (56%)

were Pru p 7 reactors on ImmunoCAP Specific IgE test. Taken together, Pru p 7 allergy seem to occur quite rarely in Italy (less than 3% among cypress reactors⁵⁹²).

GRP sensitization has to be suspected after systemic reactions that could have been associated with well-known cofactors such as physical exercise, NSAID, alcohol, proton pump inhibitors when the fruit has been consumed. Since Cupressaceae pollen allergy is a very frequent association with GRP sensitization, such pollen sensitization should be carefully evaluated even though the association mechanism is, up to now, not well understood. Cypress pollen reactivity, even after skin prick test, in the absence of Cup a 1, polcalcin or CCD IgE recognition may occur in case of GRPs' sensitization. Then, specific IgE against nsLTP is usually negative as well as against profilin. Interestingly sIgE against nsLTP or profilin was not reported in the case of cypress pollen allergy. The recombinant Pru p 7-specific IgE test, commercially available in singleplex and multiplex assays, may help in the diagnosis although a positive GRP immunoassay might not be associated with a clinically relevant IgE reactivity. Therefore, a method evaluating the IgE reactivity to the natural GRP may be helpful to confirm the diagnosis, for instance, immunoblot with total extract in nonreducing conditions. To complete the diagnosis an *ex vivo* basophil activation test could be performed with total extract and with the recombinant GRP since a positive basophil activation test, in contrast to immunoassays, strongly suggests a potential clinical relevance. Because severe reactions such as anaphylactic shock were reported, an adrenaline autoinjector should be recommended to the patient as well as avoidance of the culprit food in both raw and processed forms when the diagnosis is established. An algorithm is presented in (Figure 182).

5 – Clinical cases

Case 1 (original):

Clinical History: Male, Italy, born in 2002. Patient suffering from seasonal allergic rhinitis every year between January and March. He reported three episodes of anaphylactic reaction characterized by hypotension and diffuse urticaria with angioedema during dinner, after the ingestion of (2015) a slice of peeled peach, (2016) pomegranate (2018), and (2020) a few slices of orange. The patient in all cases was brought to the ER, where he received a combination of intramuscular adrenalin and intravenous steroid.

Allergy testing: The patient went through a cutaneous allergic evaluation that gave positive results for cypress pollen (10mm × 7 mm) and a commercial peach extract containing 30 mg/ml of Pru p 3 (12mm × 9 mm). He was then tested for IgE to cypress: 15 kUA/L; peach: 3.5 kUA/L; Pru p 1: <0.1 kUA/L, Pru p 4: <0.1 kUA/L, Pru p 3: <0.1 kUA/L and MUXF3: <0.1 kUA/L. A year later, the patient was further tested, scoring positive for Pru p 7: 14.7 kUA/L.

Conclusion: The serology identifies the patient as genuinely sensitized to Pru p 7. The presence of positive results after SPT to peach extract in the absence of PR-10, Profilin, nsLTP or CCD reactivity indicates a strong suspicion for GRP sensitization. Nowadays

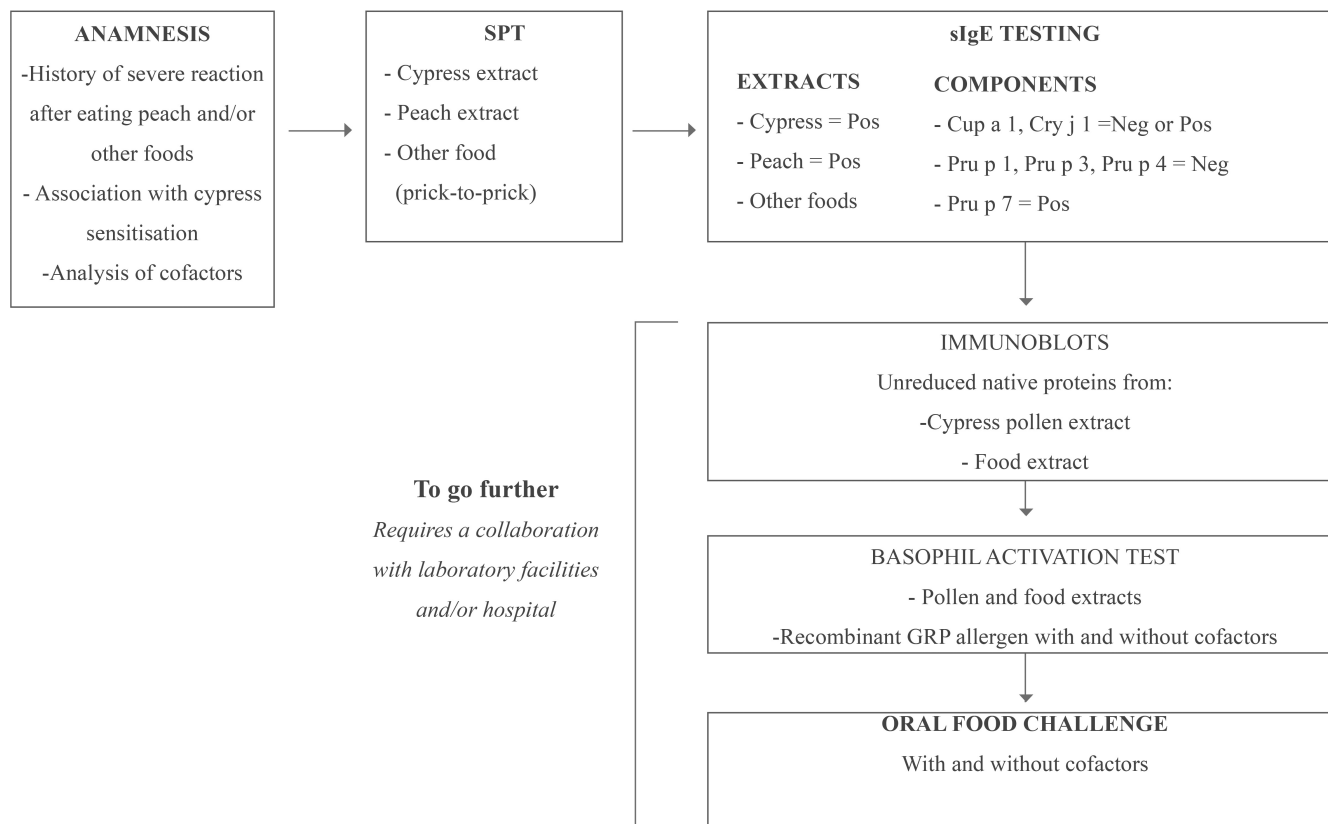


FIGURE 182 Diagnostic algorithm to assess GRP sensitization

it is possible to *in vitro* test Pru p 7, and this analysis should always be included in allergy work-out in patients with severe reactions to *Rosaceae*, pomegranate, or citrus fruits.

Case 2 (original):

Clinical History: Female, Italy, born 1990. The patient has been suffering from seasonal allergic rhinitis between February and March since 2000. After ingestion of a peeled peach and about 30 min running, she had an anaphylactic reaction (low blood pressure, abdominal pain, generalized flushing and swelling, followed by respiratory difficulty due to laryngeal obstruction) and subsequent emergency treatment. Another similar adverse reaction occurred after ingestion of two walnuts associated with moderate physical exercise.

Allergy testing: (A) SPT: Environmental allergens: Cypress pollen (*Juniperus a.*): 10 mm × 6 mm; plane tree (*Platanus a.*): 5 mm × 6 mm; olive tree (*Olea e.*): 3 mm × 2 mm; mugwort (*Artemisia v.*): 7 mm × 4 mm. Food allergens: all negative except walnut (*Juglans r. nut*): 7 mm × 5 mm and peach (*Prunus p.*): 19 mm × 8 mm. (B) *In-vitro* testing: [2015] Total IgE 350.3 kU/L, specific IgE to Cypress pollen (*Cupressus a.*): 12.5 kU/L; plane tree (*Platanus a.*): 0.66 kU/L; Olive tree (*Olea e.*): 0.12 kU/L; Mugwort (*Artemisia v.*): 2.2 kU/L; Walnut (*Juglans r. nut*) 3.82 kU/L; rPru p 3: 1.79 kU/L.

After 6 years, the patient returned to visit reporting a further reaction after physical exertion (bicycle) performed after ingesting an orange. The patient was studied with a multiplex method, which allowed to highlight, in addition to the already known

reactivity to Cypress (Cry j 1: 2.31 kU/L and Cup a 1: 31.93 kU/L) and nsLTP (Ole e 7: 1.26 kU/L; Cor a 8: 0.94 kU/L; Jug r 3: 0.35 kU/L; Art v 3: 0.52 kU/L; Pru p 3: 2.42 kU/L), also the presence of reactivity to Pru p 7 (8.34 kU/L). Interestingly, the 2015 serum stored in our serum bank was also re-tested, and so we were able to demonstrate the presence, since 2015, of a dual reactivity to Pru p 7 and Pru p 3.

Conclusion: Strict avoidance of fruits containing nsLTPs and GRPs fruit before physical exercise. AIT prescribed only for Cypress.

Case 3 (published²³⁰)

Clinical History: The patient is a 40years-old man currently living in Paris (northern France) and born in southwest France. He has suffered since childhood from cypress pollen allergy and also food allergy and he experienced an anaphylactic shock after ingestion of pomegranate (*Punica granatum*, Lythraceae family) and strong oral syndrome after ingestion of *Rosaceae* fruits (apple and peach). He has seasonal rhino-conjunctivitis during the cypress and birch pollen seasons, which overlap in the north of France, relieved by antihistaminic treatment.

Allergy testing: SPT are positive for birch and cypress pollen extracts. Specific IgE antibodies to birch (27.2 kU/L) and cypress (1.42 kU/L) pollen, citrus (1.38 kU/L), apple (2.62 kU/L), peach (1.78 kU/L), strawberry (0.49 kU/L), kiwi (0.43 kU/L) and cherry (1.99 kU/L) extracts were found with singleplex technology (ImmunoCAP Specific IgE test) and also multiplex microchips (ImmunoCAP ISAC). This patient was studied by immunoblot

against cypress pollen, peach, citrus and pomegranate extracts and Pru p 7 and snakin-1, the GRPs of peach and potato, respectively. All immunoblots were positive at low MW corresponding to a GRP-specific IgE reactivity. Moreover, basophil activation test with total allergen source extracts (cypress pollen, peach and pomegranate) and purified allergens (Cup s 7 and Pru p 7) was found positive in contrast to snakin-1 in keeping with the tolerance to potatoes mentioned by the patient.

Conclusion: Strict avoidance of *Rosaceae* fruits and especially pomegranate.

Case 4 (partially published¹⁵⁷⁷)

Clinical History: The patient is a 16-year-old Japanese girl allergic to Japanese cedar (*Cryptomeria japonica*) pollen who suffered from an anaphylactic reaction after consuming chili pepper. She was diagnosed allergic to Japanese cedar pollen when she was 10 years old. She suffered also from an allergy to apple, peach, and orange with symptoms of anaphylaxis exacerbated by physical exercise (or before menstruation) with an onset at the age of 12 years after the consumption of canned peach. At 14 years, consuming a Korean cuisine dish containing beef, bean sprout, spinach, fiddlehead fern, chili pepper, and rice, she developed anaphylaxis with symptoms of facial angioedema, systemic erythema, cough, dyspnea, and cramp. At 16 years, she again experienced a similar reaction after consuming a Chinese cuisine dish containing tofu, minced meat, and chili pepper.

Allergy testing: Specific IgE evaluation showed a high titer to Japanese cedar (220 kU/L) and cypress (31.1 kU/L) pollen extracts

together with other pollen and food sensitizations to peach (4.7 kU/L), apple (2.54 kU/L), orange (4.55 kU/L), potato (1.08 kU/L) and confirmed the sensitization to chili pepper (0.24 kU/L). She has no IgE against nsLTPs and a low titer to PR-10.

Oral food challenges to chili pepper (125 mg) or peach (30 g of canned peach) were positive inducing allergic symptoms that include anaphylaxis and required adrenaline and fluid supplement. In agreement, peach and chili pepper extracts were able to *ex vivo* activate the patient's basophils.

Studied by direct and competitive immunoblot on Japanese cedar pollen proteins, the patient showed IgE reactivities at low MW inhibited not only by Cry j 7, the GRP of Japanese cedar pollen but also by Cap a 7, the GRP from bell pepper.

When tested on bell pepper extracts this patient showed IgE reactivity to a unique cationic LMW *Capsicum annuum* protein from bell and chili pepper pulp extract. The reactivity could be inhibited by Cry j 7, Cap a 7 or Pru p 7. This patient is also allergic to potato, a species from the same family as bell pepper, Solanaceae, and an IgE reactivity was found against recombinant snakin-1, the GRP from potato.

Conclusion: This young patient is shown to be sensitized to another member of the GRP family, an allergen as yet undescribed in *Capsicum annuum*, Cap a 7. Allergy to bell/chili pepper is very rare and IgE reactivity to GRP is exceptionally reflecting a very peculiar mechanism of crossed and reinforced specific sensitization. It seems that this allergy is associated with another very rare allergy to the GRP of potato, snakin-1.

C10 - Oleosins

Uta Jappe, Ronald van Ree

Highlights

- Oleosins have a unique structure: a central hydrophobic domain flanked on each side by relatively hydrophilic domains. Oleosins are lipophilic.
- Therefore they are underrepresented in aqueous extract-based *in vitro*- and *in vivo*-routine diagnostic tests.
- Oleosins are resistant to heat and enzymatic processing.
- An increase in allergenicity has been observed for peanut and hazelnut oleosins after roasting when compared to raw seeds.

1 - The protein

In 1998, Olszewski and co-workers reported an allergenic protein present in peanut oil.¹⁵⁷⁶ After its purification and identification as peanut oleosin, they could show in 2002 IgE-binding in sera of 3 peanut-allergic patients.^{1577,1578} Moreover, they provided the first data for increased allergenicity of oleosins from peanuts that were roasted,¹⁵⁷⁸ which was later confirmed by Schwager et al., 2017.¹²³⁶ Oleosins are lipophilic, which is due to the division of the primary sequence into three defined structural domains: a central hydrophobic domain of 72 amino acids flanked on each side by relatively hydrophilic domains.¹⁵⁷⁹ This feature is unique. It is the hydrophobic domain that is embedded into the oil body membrane whereas the hydrophilic parts reside on the surface and interact with the head groups of phospholipids (Figure 183).¹⁵⁷⁹⁻¹⁵⁸¹ The N-terminal domains are either amphipathic or hydrophilic, the C-terminal part is amphipathic. Oleosins are heat and digestion resistant (Table 102).

The molecular weight ranges from 14 kDa to 17 kDa. A BLAST search of the identified IgE-binding sequences revealed a sequence similarity between oleosins (Figure 184)¹²³⁶. Since this method is limited to the detection of sequential epitopes, conformational epitopes responsible for allergic cross-reactions between oleosins of different sources are not included.

2 - The family

Oleosins are stabilizing proteins of the membrane of seed oil bodies, which are lipid storage organelles (Figure 183). They consist of a lipid core, surrounded by a single layer of phospholipids and embedded proteins, the oleosins, caleosins (~30 kDa)¹⁵⁸¹⁻¹⁵⁸⁵ and steroleosins (~40 kDa). Among these proteins, the oleosins represent 80-90% of total protein.¹⁵⁸⁶ So far, oil bodies have been detected in diverse plants like peanut, walnut, hazelnut, soybean, sesame, maize, rapeseed, and sunflower.¹⁵⁸² Ten allergens from 4 different plant sources (peanut, hazelnut, sesame, and buckwheat) are presently documented in the WHO/ IUIS allergen nomenclature database¹⁵⁸⁷ (Table 103).

3 - Clinical relevance

After a hazelnut oleosin was obtained by cloning in 2006 and hypothesized to be a new allergen,¹⁵⁸⁷ two oleosins (Cor a 12 and Cor a 13)

TABLE 102 Characteristics of the prototype protein, Ara h 15

Characteristics of the prototype protein, Ara h 15	
Allergen source	Peanuts
Protein family	Oleosins
UniProtKB accession No	Q647G3
Three-dimensional structure available	No
Molecular structure	The primary sequence is divided into three defined structural domains: a central hydrophobic domain flanked on either side by relatively hydrophilic domains
Theoretical molecular weight	16875,16 Da
Length	166 amino acids
Ligand binding	Unknown
Dimerization	Yes
Glycosylation	No sites predicted
Disulfide bonds	No
Isoelectric point	8.99
Synthesis	Details not available

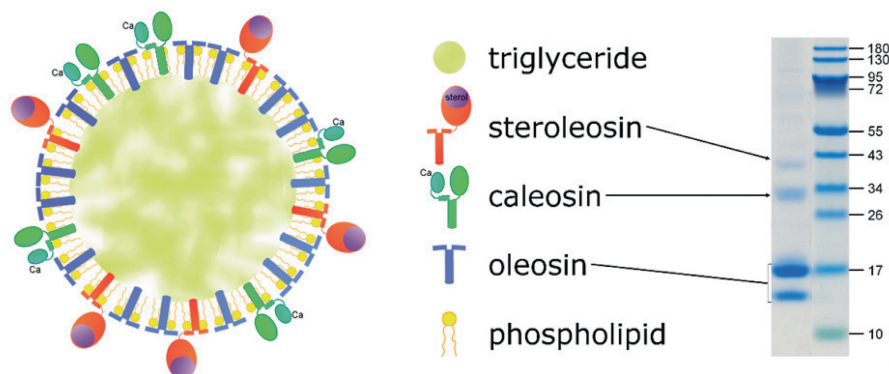


FIGURE 183 Schematic model of an oil body with its components (left) and the determination of the molecular mass of oil body proteins from peanut by SDS-polyacrylamide gel electrophoresis (right), taken from¹⁵⁸⁰

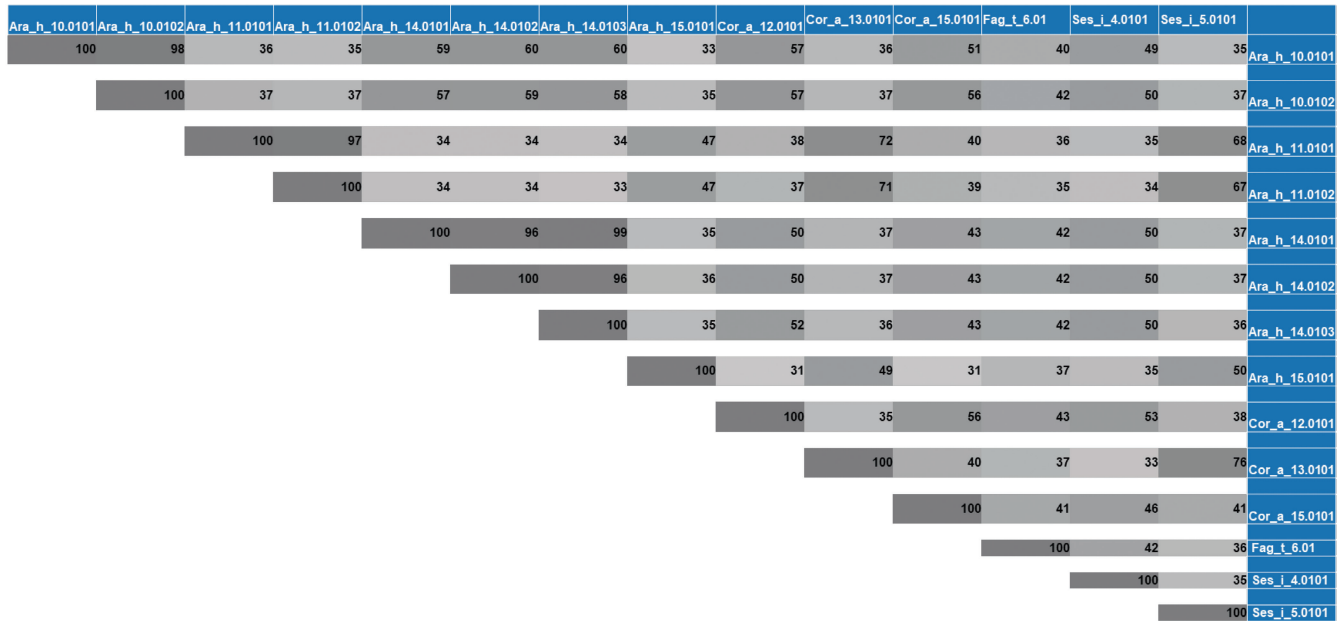


FIGURE 184 Similarity of sequences between oleosins in % (all isoforms included) that are documented in www.allergen.org. Melanie Plum, PhD, Research Group Uta Jappe, Research Center Borstel, Germany.

TABLE 103 Oleosins documented by the WHO/IUIS allergen nomenclature subcommittee [1580, modified]

Botanical family	Allergen source	Allergen	Molecular weight (kDa)
Fabales	Peanut (<i>Arachis hypogaea</i>) [1236, 1578, 1590]	Ara h 10	16
		Ara h 11	14
		Ara h 14	17.5
		Ara h 15	17
Fagales	Hazelnut (<i>Corylis avellana</i>) [62, 1588, 1589]	Cor a 12	17
		Cor a 13	14-16
		Cor a 15	17
Lamiales	Sesame (<i>Sesamum indicum</i>) [1593, 1600]	Ses i 4	17
		Ses i 5	15
Caryophyllales	Tartarian buckwheat (<i>Fagopyrum tataricum</i>) [1591, 1592]	Fag t 6	18

were subsequently shown to be allergenic in 2014⁶² and accepted by the WHO/IUIS allergen nomenclature subcommittee.¹⁵⁸⁷ In 2021, a third was described, Cor a 15.¹⁵⁸⁹ Cor a 15 was the oleosin that was predominantly bound by IgE in an Italian cohort of hazelnut-allergic children. According to the authors, some allergic children recognized solely oleosins by their IgE, which so far is in contrast to patients with peanut and sesame allergy. In this case, hazelnut oleosins would enrich molecular allergy diagnostics immensely in a subpopulation of hazelnut-allergic children.¹⁵⁸⁶

In 2015, the allergenicity of Ara h 10 and Ara h 11 from peanut was published together with the identification of additional allergenic peanut oleosins, Ara h 14 and Ara h 15. The allergenic potential of the oleosin initially observed in peanut oil^{1236,1576,1590,1626} was now shown in a larger cohort of peanut-allergic subjects.¹²³⁶ Most probably, oleosins from other plant species (soybean, flax, walnut,

sunflower [summarized in¹⁵⁸⁰]) might cause allergic reactions, as well. An IgE-binding epitope of Ara h 15 was shown to be cross-reactive with buckwheat,¹⁵⁹¹ which suggested oleosins to be present in this source. This was recently confirmed.¹⁵⁹² In addition to the general feature of allergenicity, oleosins from peanut, hazelnut and sesame have been associated with severe allergic reactions.^{62,1236,1590,1593} This has been confirmed in 2017 for a cohort of peanut-allergic patients (of meanwhile above n=70), where only those with severe reactions to peanut and not those with mild or moderate symptoms, had IgE to oleosins. Although these patients were also IgE-positive for Ara h 2, this points to oleosins as marker allergens for the severity of a reaction,¹²³⁶ and so far, foods known to contain allergens from the oleosin family are requiring labelling on food products. It was shown that roasting increased IgE binding to peanut oleosins¹²³⁶ and hazelnut oleosins.¹⁵⁸⁹

Ehlers and co-workers investigated the diagnostic relevance of recombinantly expressed and native sesame oleosins. They observed no allergic individuals with an oleosin mono-sensitization but always a simultaneous recognition of other sesame allergens.¹⁵⁹⁵ In addition, nonallergic individuals also had IgE to sesame oleosins, which is different for peanut oleosins that were only recognized by IgE in sera from patients with severe peanut allergy.¹²³⁶ Up to 30% of sesame allergic patients cannot be diagnosed by routine allergy diagnostic tests, and according to Ehlers and co-workers, they will at present not profit from the addition of Ses i 4 and Ses i 5 to the diagnostic allergen panel.¹⁵⁹⁵ However, it is plausible that the application of hydrophobic interaction chromatography as a last purification step to eliminate impurities of seed storage proteins from the oleosin fraction has maybe led to the disruption of lipids, which may be important for the recognition of sesame oleosins.

Cross-reactivity was hypothesized from the observation that an IgE-binding amino acid sequence in the C-terminal part of the Ara h 15 is also found with a high degree of homology in oleosins from several other food allergen sources, such as hazelnut, rapeseed, soy, sesame, and almond.¹²³⁶

In the large EuroPrevall outpatient clinic survey in 12 European cities, 13% of patients reporting hazelnut allergy were sensitized to nCor a 12. Although the prevalence of sensitization was higher in patients reporting severe symptoms than in those with mild to moderate symptoms, a significant association with severity was not demonstrated.⁴⁵

4 – Clinical management

Clinical diagnosis: Patients with severe food allergic reactions to nuts, legumes and seeds are presently investigated for IgE against storage proteins and/or lipid transfer proteins because these allergens are widely accepted as potential markers. However, concerning anaphylactic reactions to lipid-rich representatives of these food allergen sources, there has been an increasing suspicion that severe reactions may also be associated with oleosins. Support for this has recently been reported.¹²³⁶ Unfortunately, the lipophilic nature of this family of proteins has hampered the development of reliable CRD reagents for oleosins, both singleplex and array-based until recently.^{1236,1596} There are now reports on recombinant oleosins being used in arrays, as they are soluble in aqueous solutions.

Case history: In general, it can be recommended to test IgE against oleosins if available.

Skin prick test: Oleosins will be underrepresented in skin prick test solutions⁶² since these are also based on aqueous solutions.

Only a prick-to-prick test with native foods can be expected to include natural oleosins. In this regard, “Tahini” sauce may be helpful as it allows *in vivo* detection of sesame sensitization. It may even be helpful for the diagnosis of peanut allergic individuals without IgE against Ara h 2 and sesame allergic individuals without IgE to seed storage proteins.¹⁵⁹⁷

IgE-detection assay: So far, a recombinant oleosin from peanut is now applied on the ALEX2 array^{44,1598} (A naturally purified hazelnut oleosin was used in ImmunoCAP in the investigation by Datema et al.⁴⁴ but is not yet commercially available).

Treatment: The treatment of severe reactions to foods containing oleosins is still strict avoidance. The patients should be provided with an emergency kit. So far, only for peanut allergy, oral allergen immunotherapy has recently been authorized (see chapter B18).

5 – Clinical cases

Clinical history: An eight-month-old girl with generalized atopic eczema (SCORAD 67) who had been solely breastfed experienced sincere flare-ups of eczema a couple of days after coming home from the Dermatology clinic where she had been treated. Eventually, a trigger of eczema was suspected in the domestic situation. A thorough environmental history revealed that peanut butter was regularly consumed, a habit introduced by the mother who was US American. The child itself had never consumed peanuts in any form.¹⁵⁹⁹

Diagnostic and therapeutic considerations: The allergens contained in peanut butter were suspected to be responsible for the worsening of her eczema, whenever she returned home from the hospital. An atopy patch test was performed and confirmed peanut to induce eczema. The investigation for a filaggrin mutation was negative. First series of IgE tests—Total serum IgE >100 IU/L; IgE to peanut extract: 71 kU/L. Further IgE tests—Molecular allergy diagnostics revealed IgE to Ara h 1: >100 kU/L; Ara h 2: 41 kU/L; Ara h 3: 24.7 kU/L; Ara h 6: >100 kU/L; Ara h 8: 0.1 kU/L; Ara h 9: 0.49 kU/L.

Testing IgE to new allergen molecules—Several years later, after peanut oleosins had been identified and purified by us, her serum sampled for the first investigations was tested positive in immunoblot for IgE against the peanut oleosins Ara h 10, Ara h 11 and Ara h 14, Ara h 15.¹²³⁶

Diagnosis and therapy: The fact that without consumption of peanuts such a strong sensitization towards storage proteins, defensins and oleosins, all associated with severe allergic reactions to peanut consumption had taken place strongly speaks in favor of a cutaneous sensitization. Peanut butter was removed from the household, the house was thoroughly and repeatedly cleaned.

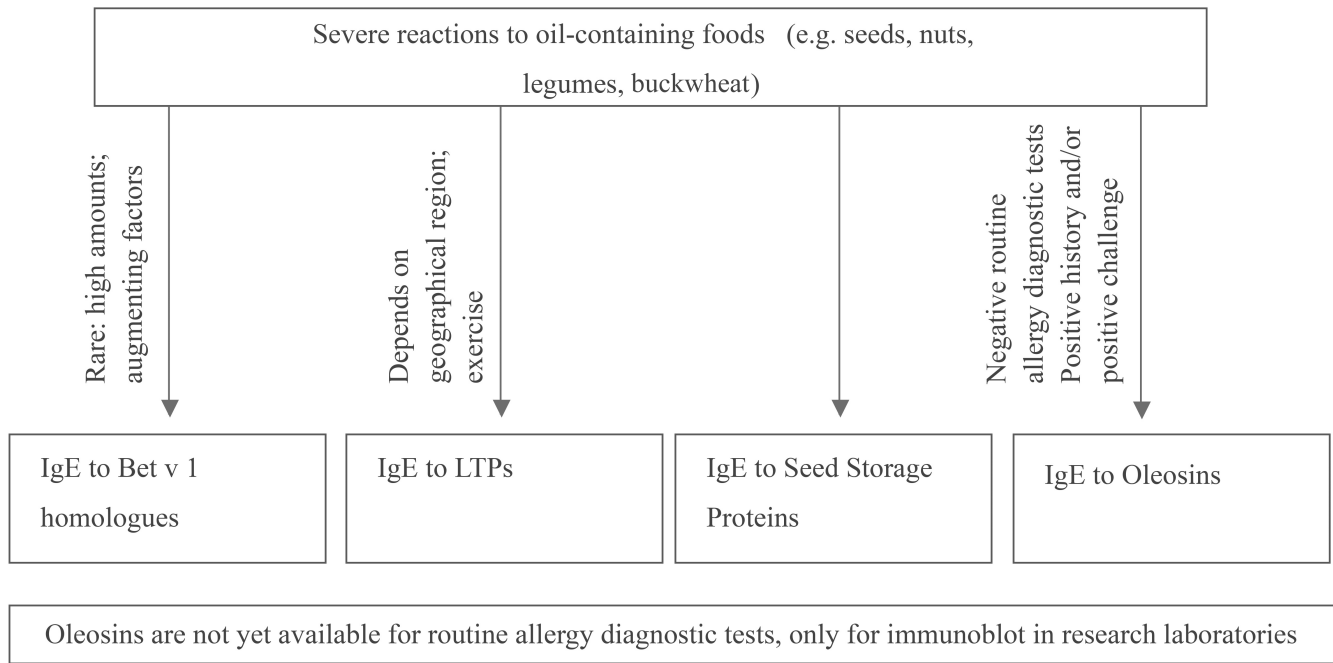


FIGURE 185 Decision algorithm

Absolute avoidance of peanuts in the future was advised for the little girl (Figure 185).

Most important protein or family characteristics

Oleosins are lipophilic and therefore not present in aqueous extract-based routine diagnostic *in vitro* and *in vivo* tests.⁶² They are resistant to heat and enzymatic processing. An increase in allergenicity has been observed for peanut and hazelnut oleosins after roasting when compared to raw seeds.^{1236,1589}

- Remarkable or important clinical aspects**
- Oleosins are potential marker allergens for allergy severity after peanut and hazelnut consumption.^{62,1236,1589}
 - Risk assessment of anaphylaxis is possible by the detection of IgE to oleosins.
 - Precision medicine optimization may make risky and expensive oral challenge tests superfluous.
 - The basophil activation test with peanut oleosins truly discriminates between allergic and sensitized individuals.^{1236,1596}

C11 – Parvalbumins

Denise Schrama, Tanja Kalic, Martine Morisset, Lars K. Poulsen, Annette Kuehn

Highlights

- Food, respiratory and contact allergens.
- Fish pan-allergens resistant to food processing.
- Clinical cross-reactivity is based on the presence of highly conserved IgE epitopes.
- Low cross-reactivity between beta-parvalbumins from bony fish and alpha-parvalbumins from cartilaginous fish.
- Monosensitized patients have IgE to species-specific epitopes.

1 – The protein

In the early seventies, Gad c 1 was the first parvalbumin identified as major fish allergen in Baltic cod (*Gadus callarius*).¹⁶⁰⁹ Subsequent cloning and biomolecular studies were performed with the parvalbumin Gad m 1, the homologous allergen from Atlantic cod (*Gadus morhua*) (Table 104).^{195,1015} Gad m 1 is used as a representative allergenic parvalbumin in many studies. Currently, two isoallergens are listed in the official allergen nomenclature database (www.allergen.org), Gad m 1.01 and Gad m 1.02. Each isoallergen has been characterized as two isoforms (variants) of high sequence identity. The protein structure of cod parvalbumin was first modeled on the basis of the x-ray structure from carp parvalbumin, Cyp c 1. In 2014, the NMR-based protein structure was published, revealing the important characteristics on the folding and stability of parvalbumins.¹⁶¹⁰ Gad m 1 has a six alpha-helical protein fold, which is a common feature of parvalbumins (Figure 186). Since then, structures of several other allergenic fish and non-fish parvalbumins were determined.

Gad m 1 was identified as the major allergen in cod muscle. However, food allergy to codfish can also be caused by other allergens, such as Gad m 2 (cod enolase) and Gad m 3 (cod aldolase) (see Chapter B12).¹⁰²⁴ Cod parvalbumin, a highly heat-stable protein of low molecular weight (10–12 kDa), binds Ca²⁺-ions (or Mg²⁺-ions) via two loops called EF-hand motifs.¹⁶¹¹ It is involved in the regulation of the intracellular calcium concentration during muscle relaxation.¹⁶¹¹ As all bony fish, cod has two types of muscles, light and dark, which differ by their physiological function. Cod belongs to the whitefish and has mainly light muscle tissue and only a small strip of dark tissue underneath the skin. Parvalbumins are more abundant in the light muscles than the dark ones as described for tuna.¹⁶¹² In cod, the parvalbumin level is up to 2 mg per g of muscle tissue (see chapter B12 “Fish allergy” for information on other species).¹⁰⁰⁹ B cell epitopes have been determined for cod parvalbumin.^{1015,1613} Several regions of the protein seem to be involved in the antigen-antibody interaction. A correlation was found between the severity of the allergic reaction and the number of epitopes recognized by patients' IgE. Allergic patients who recognized ten IgE-binding

TABLE 104 Basic protein characteristics of Gad m 1

Basic protein characteristics of Gad m 1	
Allergen source	<i>Gadus morhua</i> , Atlantic cod
Protein family	Parvalbumin
UniProtKB accession No	Q90YL0
Three-dimensional structure available	Yes
Molecular structure	Alpha-helical structure
Theoretical molecular weight	11.55 kDa
Molecular weight measured by mass spectrometry	11.36 kDa
Length	109 amino acids residues
Ligand binding	Yes (Ca ²⁺ , Mg ²⁺)
Oligomerization	Dimers, oligomers
Glycosylation	No
Disulfide bonds	No
Isoelectric point	4.58
Synthesis	Muscle tissue, cytosolic protein
Distribution	Muscle, swimbladder



FIGURE 186 A ribbon model of the three-dimensional structure of cod parvalbumin Gad m 1 (PDB: 2MBX). Two calcium ions (purple) are bound by two functional EF-hand motifs. The model was created by ChimeraX (<http://www.cgl.ucsf.edu/chimerax/>).

peptides including an important C-terminal epitope had more severe reactions than others.¹⁶¹³ It was concluded that the number of linear epitopes could serve as a marker for the severity of the allergic reaction. A strategy for immunotherapy using hypoallergenic parvalbumin has been developed but is unavailable for clinical practice.^{429,1614}

So far, successful oral immunotherapy for allergy to cod has only been reported for patients treated with boiled cod.¹⁶¹⁵

2 - The family

Based on their protein characteristics, parvalbumins are attributed to two different phylogenetic origins, the alpha- and the beta-lineage.¹⁰³¹ Both subtypes can be found in different organs (central nervous system, endocrine tissue), but the highest expression rates have been determined in muscles.³²⁹ Muscles from mammals and birds express alpha-parvalbumins, which are considered as rarely allergenic proteins.¹⁹⁵

Parvalbumins of the beta-subtype have been characterized as pan-allergens in fish muscle.¹⁰³¹ They belong to the EF-hand protein superfamily comprising important allergens from both animal and plant origin (see also chapter C06 "Polcalcins"). These proteins share conserved domains consisting of Ca²⁺-binding peptide loops flanked on both sides by α -helices. These structures are called EF-hand motifs as both α -helices are arranged like the thumb and the

forefinger of a hand. Fish parvalbumins have three EF-hand motifs (AB, CD, EF) but only the CD- and EF-motifs are functional and bind divalent cations (Ca²⁺, Mg²⁺). Parvalbumin structures rearrange globally upon ion-binding or release. The ion-binding capacity is essential for the correct parvalbumin function and its IgE-binding capability.⁴³⁰ Parvalbumins with unfunctional calcium-binding sites bind IgE antibodies from fish-allergic patients only weakly.³²⁹ Therefore, the functional calcium-binding motifs (CD, EF) have been suggested as important conformational B cell epitopes.

Textbox Parvalbumin family characteristics

- Parvalbumins are members of the Ca²⁺-binding EF-hand superfamily.
- Clinical cross-reactivity is based on the presence of highly conserved IgE epitopes.
- Monosensitized patients have IgE to species-specific epitopes.

TABLE 105 Gad m 1 - homologous allergens from several fish and non-fish species

Taxonomic order	Allergen source	Allergen
Anura	Edible frog (<i>Rana esculenta</i> / <i>Pelophylax esculentus</i>)	Ran e 2*
Carcharhiniformes	Edible shark (<i>Mustelus griseus</i>)	Mus g 1
Clupeiformes	Atlantic herring (<i>Clupea harengus</i>)	Clu h 1*
	Pacific pilchard (<i>Sardinops sagax</i>)	Sar sa 1*
Crocodylia	Australian saltwater crocodile (<i>Crocodylus porosus</i>)	Cro p 1*
Cypriniformes	Grass carp (<i>Ctenopharyngodon idella</i>)	Cten i 1*
	Common carp (<i>Cyprinus carpio</i>)	Cyp c 1*
Gadiformes	Baltic cod (<i>Gadus callarias</i>)	Gad c 1*
	Atlantic cod (<i>Gadus morhua</i>)	Gad m 1*
	Atlantic hake (<i>Merluccius merluccius</i>)	Mer mr 1
	Alaska pollock (<i>Gadus chalcogrammus</i>)	The c 1
Galliformes	Chicken (<i>Gallus gallus domesticus</i>)	Gal d 8*
Perciformes	Barramundi (<i>Lates calcarifer</i>)	Lat c 1*
	Yellowfin tuna (<i>Thunnus albacares</i>)	Thu a 1*
	Swordfish (<i>Xiphias gladius</i>)	Xip g 1*
Pleuronectiformes	Megrim (<i>Lepidorhombus whiffiagonis</i>)	Lep w 1*
	Common sole (<i>Solea solea</i>)	Sole s 1*
Salmoniformes	Rainbow trout (<i>Onchorhynchus mykiss</i>)	Onc m 1*
	Atlantic salmon (<i>Salmo salar</i>)	Sal s 1*
Scombriformes	Indian mackerel (<i>Rastrelliger kanagurta</i>)	Ras k 1*
	Atlantic mackerel (<i>Scomber scombus</i>)	Sco s 1*
Scorpaeniformes	Redfish (<i>Sebastes marinus</i>)	Seb m 1*
Siluriformes	Striped catfish (<i>Pangasianodon hypophthalmus</i>)	Pan h 1*

* Allergens officially accepted and designated by the WHO/IUIS Allergen Nomenclature Sub-Committee (www.allergen.org); all others are unofficial names taken from the Allergome database (www.allergome.org).

* Allergens officially accepted and designated by the WHO/IUIS Allergen Nomenclature Sub-Committee (<http://www.allergen.org>); all others are unofficial names taken from the Allergome database (<http://www.allergome.org>).

especially in the ion-binding regions.^{195,1015} The surface comparison of selected cross-reactive fish allergens visualizes potential conformational B cell epitopes common to most parvalbumins (Figure 187).

However, a number of patients react only to specific or single fish. Tolerance of single species might be explained by very low allergen contents such as for tuna.¹⁰⁰⁹ Another reason for this clinical mono-/oligo-sensitivity are species-specific IgE-binding epitopes present on parvalbumins.¹⁶¹⁶ It was also recently described that cartilaginous fish may be tolerated by patients sensitized to bony fish due to a low cross-reactivity between their only distantly related parvalbumins.²⁰⁸ Studies on monosensitization to salmon/trout confirmed the presence of a salmonid-specific parvalbumin epitope, which is unique for these fish allergens¹⁶²¹ (Figure 188).

Figure 189 represents documented and putative cross-reactivities among known fish and non-fish parvalbumins. During the past decade, new fish allergens have been characterized (see chapter B12). Future studies will have to address the characterization of selective marker molecules, parvalbumins and the new fish allergens, for IgE-based diagnosis to discriminate between patients with clinical cross-reactivity and fish species-specific sensitization.

The use of basophil activation assays with fish allergens appears to be promising and potentially exceeds the performance of simple IgE-binding assays.^{208,1617} Their diagnostic relevance still needs to be further explored.

3 – Clinical relevance

Beta-parvalbumins are present in fish muscle and skin, but they become airborne upon handling and processing of fish.¹⁰¹⁵ As such, they are both food and respiratory allergens but also potential contact allergens for occupationally exposed workers. Fish allergy is important in the domestic, public and occupational environment. Incidental episodes might occur upon inhalation of volatile allergens during fish preparation in the domestic environment. These allergens can be present as hidden allergens, for example, as contaminations of food that is not expected to contain fish and products thereof.⁵⁵⁸ Respiratory problems of the upper and lower airway tract have been reported in the occupational context among workers processing fish.¹⁰⁵² Both beta and alpha parvalbumins were shown to efficiently cross the epithelial barrier *in vitro*.¹⁶¹⁸ A clear correlation has been

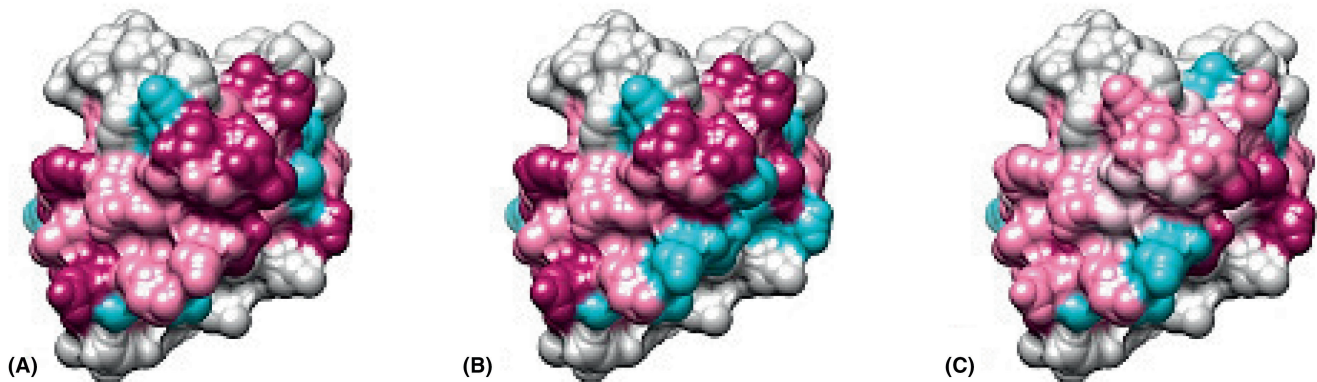


FIGURE 187 Surface comparisons of three different cross-reactive parvalbumins (based on PDB 2MBX, sequence conservation determined using the ConSurf tool). A. Cod Gad m 1, B. Salmon Sal s 1, C. Tuna Thu a 1; colored according to protein identity between Gad m 1 and the two others: blue, variable; white, average; purple/pink, conserved

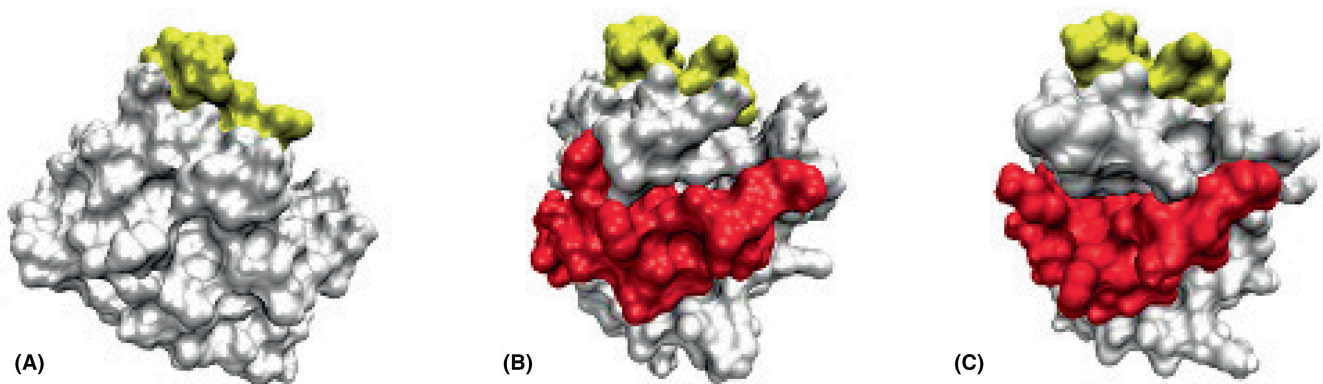


FIGURE 188 Surface comparisons of non-cross-reactive parvalbumins in salmonid-monosensitized patients (based on PDB 2MBX, sequence conservation determined using the ConSurf tool). A. Cod Gad m 1, B. Salmon Sal s 1, C. Trout Onc m 1. Yellow, Ca²⁺-binding sites; red, species-specific epitopes

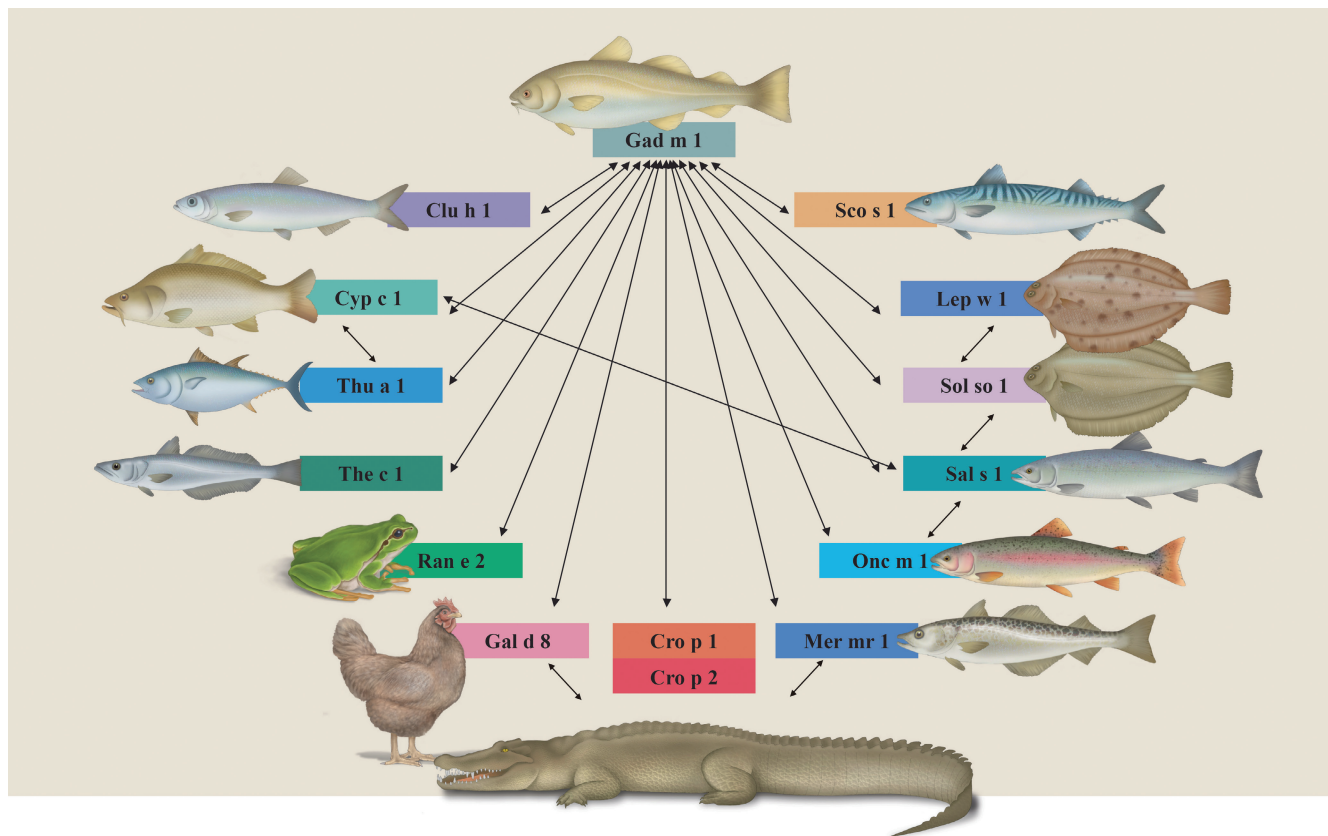


FIGURE 189 Cross-reactivities among allergenic fish and non-fish parvalbumins. All parvalbumins have a high potential for cross-reactivity based on high sequence homology. Lines represent documented IgE-cross-reactivity. Clockwise: Atlantic cod, Atlantic mackerel, megrim, common sole, Atlantic salmon, rainbow trout, Atlantic hake, crocodile, chicken, edible frog, Alaska pollock, yellowfin tuna, common carp, Atlantic herring

shown for the development of work-related asthma and fish allergy as explained by the high environmental fish allergen concentrations in the workplace.

Studies estimated that <1% of the general population suffers from an allergy to fish (see chapter B12).³²⁹ Children often maintain their clinical allergy to fish during adolescence.⁹⁷⁶ However, a recent study reported that the tolerance of fish increases from childhood into adulthood, with about half of the fish-allergic children reaching fish tolerance in adolescence.¹⁰³⁵ Fish allergy is more frequent in countries with large coastal regions characterized by frequent fish consumption and settling of fish-processing industries. Concerning the prevalence of specific IgE to parvalbumins in fish-allergic patients, it has been stated for a long time that more than 90% are sensitized to this pan-allergen. According to results of more recent studies, this prevalence seems to be considerably lower (see chapter B12). However, parvalbumin appears to still be the major allergen.¹⁹⁵

The main route of sensitization to fish parvalbumins is thought to be by ingestion, thus by uptake through the gastrointestinal tract. Epidermal or airway sensitization might also play a role, especially in children with active atopic dermatitis at the time of solid food introduction into diet¹⁰³⁵ and through inhalation of airborne allergens in occupational settings.¹⁰¹⁴ Common clinical manifestations include mild (oral allergy syndrome, erythema) to moderate (urticaria, vomiting, diarrhea) or severe (angioedema,

bronchospasm, anaphylaxis) symptoms.^{195,1015} Sensitized patients on antacid medication are at higher risk to develop severe reactions than others.¹⁶¹⁹

A key feature of potent food allergens is their stability to thermal treatments. Fish parvalbumins are extremely heat stable, and therefore, they are still detectable in products processed by cooking or frying or in pickled food.¹⁰⁰⁹ This emphasizes their undiminished allergenicity upon various food preparation methods. Fish parvalbumins become glycosylated by heating in the presence of glucose through the Maillard reaction. However, the resulting effects on their allergenic potency, be it cumulative or diminishing, still require further investigations.

Textbox Clinical relevance

- Parvalbumins are fish pan-allergens.
- Parvalbumins are food, respiratory and contact allergens.
- Beta-parvalbumins retain IgE-binding properties upon food processing.
- Low cross-reactivity between beta-parvalbumins from bony fish and alpha-parvalbumins from cartilaginous fish has been observed.

Currently, there is no causal therapy available to treat allergic sensitization to fish parvalbumins. The therapeutic desensitization with increasing doses of fish is disadvised in clinical routine practice, as the risk for anaphylactic reactions cannot be ruled out. Often, a strict avoidance diet is recommended—except for selectively tolerated species (see chapter B12). Caution is advised with products of fish origin, which might be contaminated with parvalbumins or contain other fish allergens (fish collagen and gelatin). An important perspective for the future treatment of fish allergy could be the development of hypoallergenic low IgE-binding parvalbumins,⁴³⁰ (see Chapter A09). Beyond, novel procedures in fish farming, tailored to reduce the allergenicity of fish parvalbumin, might be another prospective approach.¹⁶²⁰

4 - Clinical management

The mainstay for the diagnosis of fish allergy are the record of the patient's medical history, the analysis of the skin prick test reactivity using fish extracts or the dorsal-rostral part of selected fish or the potentially symptoms-eliciting food source, the quantification of serum IgE antibodies, and in some cases, oral food challenges (see chapter "Fish allergy"). Commercial IgE-quantification assays have long been available from Thermo Fisher Scientific (ImmunoCAP Specific IgE test and ImmunoCAP ISAC, www.thermofisher.com) for about 30 extracts from different fish species as well as two recombinant parvalbumins, Gad c 1 from cod and Cyp c 1 from carp. A recently developed ALEX2 multiplex platform (MacroArray Diagnostics, www.macroarraydx.com) made available a number of parvalbumins and total extracts from several fish species, along with other fish allergens such as cod enolase and cod aldolase (6 different fish species plus 9 fish allergens).

Highly sensitized patients often react to various fish. First, they should be cautiously tested, due to potential reactions, for skin reactivity to cod, salmon and the symptoms-eliciting fish, followed by analysis of specific IgE binding to cod and salmon extract. Second, a polysensitization to fish can be confirmed by detecting specific IgE to the cross-reactive parvalbumin from cod (Gad m 1). Future IgE testing for other allergens will entail a more specific diagnosis

of these patients. With the advent of novel IgE-multiplexing platforms, the testing of sensitization to parvalbumins from distantly related bony fish as well as cartilaginous fish such as ray, is possible. Indeed, if this IgE testing in parvalbumin-positive patients is negative (Figure 190), there is a high probability that ray will be tolerated,²⁰⁸ which needs to be confirmed by oral provocation.

Textbox Advices

- Perform skin testing with cod and salmon muscle.
- Be aware that a false negative result might be obtained with dark fish muscle!
- Test specific IgE to cod and salmon extract.
- Test specific IgE to purified cod parvalbumin.

However, a number of fish-allergic individuals react to specific fish only.^{1024,1035} The challenge of future studies will be the identification of marker allergens for IgE tests to discriminate between these poly- and oligo-/ mono-sensitized patients. As for now, the discriminative significance of anti-parvalbumin IgE antibodies seems to be limited because they are often cross-reactive with various homologues, which does not necessarily imply a clinical reactivity. An exception has been reported for a subgroup of patients with mono-sensitivity to salmonid fish. They might be diagnosed efficiently by determination of specific IgE to salmon and trout parvalbumin (see "Clinical case 2").¹⁶²¹ However, the positive predictive value (PPV) for single parvalbumins in the diagnosis of allergy to single fish still needs to be defined.

Overall, allergens different from parvalbumins might be elicitors for fish allergy. Cod enolases and aldolases have been identified as responsible allergens in three clinical cases of mono-sensitivity to cod (see Chapter B12).¹⁰³⁷ Even other allergens such as fish gelatin, fish collagen and others might play a role in this context (Figure 191)^{1012,1025} Anyway, diagnostic conclusions from *in vitro* IgE results, especially negative results, should be confirmed by further oral provocation tests in case of a strong suspicion of a fish allergy.

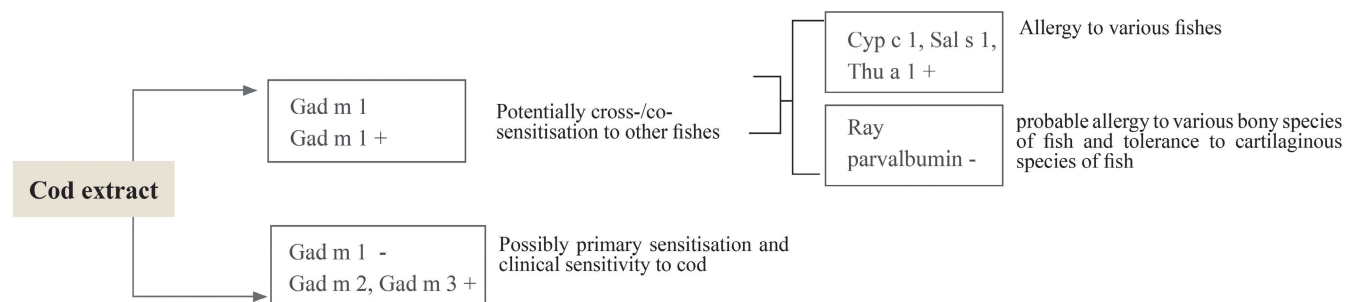


FIGURE 190 Added value of the use of single allergens in the case of a positive IgE test to cod extract

5 – Clinical cases

In the clinical cases presented in this paragraph, the following parvalbumins have been included in IgE-based diagnostic procedures during research studies: salmon Sal s 1, carp Cyp c 1, cod Gad m 1, tuna Thu a 1, trout Onc m 1, crocodile Cro p 1.

Case 1 (published¹⁰¹⁹)

Clinical History: A male child, 12 years old, with a clinical history of fish allergy since early childhood presenting with angioedema and respiratory problems upon ingestion of different fish as well as with acute urticaria when touching fish.

Test with extracts: Skin tests performed with commercial extracts were positive for cod, salmon and tuna. IgE to cod, salmon and tuna extract were positive (16 kU/L, 32 kU/L and 65 kU/L, respectively).

Food challenge: The parents of the child refused a food challenge.

Test with molecules: Cod, salmon and tuna parvalbumins were positive in IgE ELISA (20 kU/L, 18 kU/L and 30 kU/L, respectively).

Conclusion: The polysensitization to multiple fish species was confirmed in this case by revealing cross-reactive IgE antibodies to homologue parvalbumins from different species. (Figure 192)

Case 2 (published¹⁶²¹)

Clinical History: A female patient, 21 years old, with a clinical history of fish allergy since childhood presenting with swelling of the tongue and oral mucosa, facial edema and vomiting minutes after ingestion of salmon or trout.

Test with extracts: Skin tests performed with commercial extracts were positive for salmon and trout but negative for other fish. Only IgE to salmon extract was slightly positive (0.4 kU/L).

Food challenge: As the patient repeatedly experienced symptoms with salmonid fish, she refused to be tested by oral provocation.

Test with molecules: As determined by IgE ELISA, salmon and trout parvalbumins were positive at 0.2-0.4 kU/L. No inhibition assays were performed with other fish parvalbumins as IgE binding was negative for cod, carp, mackerel, redfish and herring homologues.

Conclusion: In this case, clinical species-specific sensitivity to salmonid fish was confirmed by specific IgE to salmon and trout parvalbumin (Figure 193).

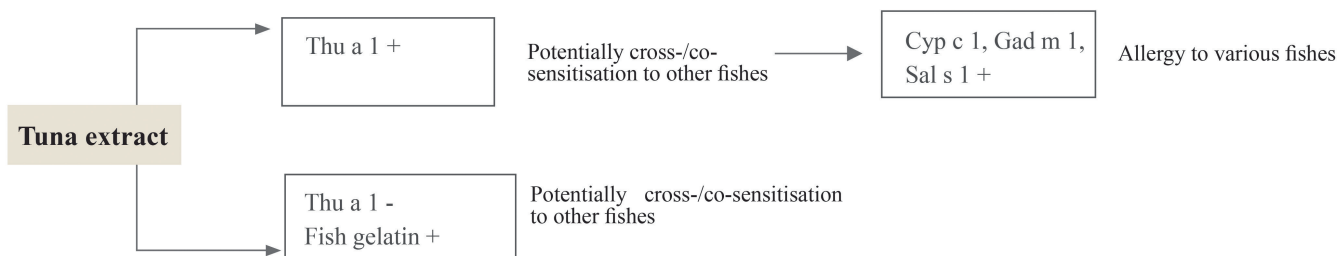


FIGURE 191 Added value of the use of single allergens in the case of a positive IgE test to tuna extract

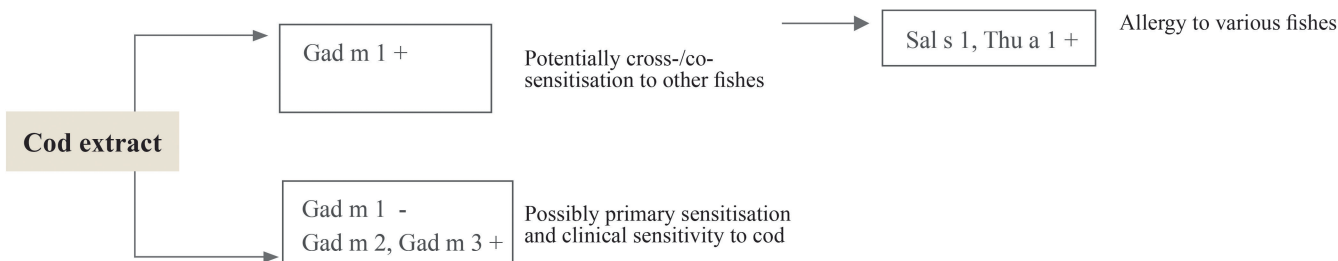


FIGURE 192 Diagnostic procedure for case 1

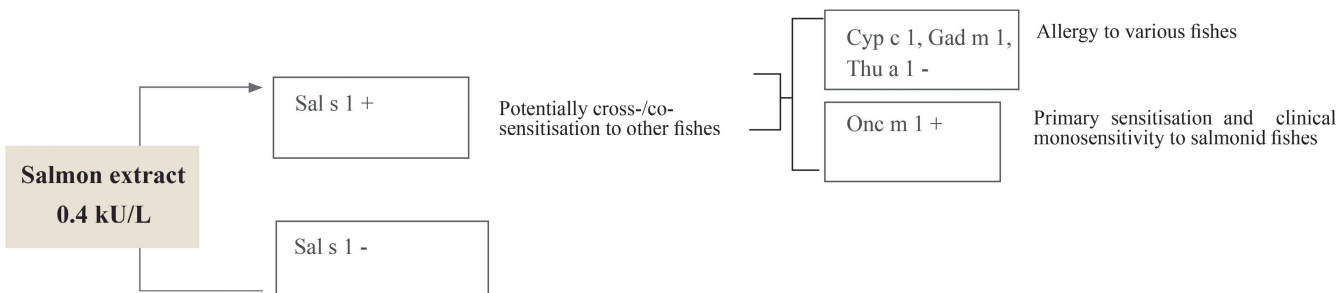


FIGURE 193 Diagnostic procedure for case 2

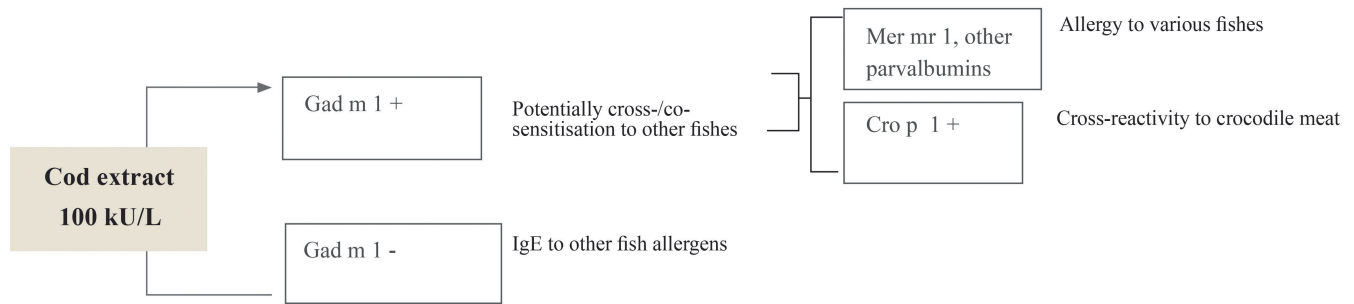


FIGURE 194 Diagnostic procedure for case 3

Case 3 (published¹⁶²²)

Clinical History: Male patient, 9 years old, presenting with intense oral itching, perioral erythema, dyspnea, and generalized urticaria within minutes of eating a small portion of crocodile burger for the first time.

Test with extracts: Skin tests with commercial extracts were positive for most fish (cod, salmon, trout, tuna, anchovy, megrim, sole, hake, anglerfish, sardine) but negative for swordfish. Prick-to-prick was positive with raw and cooked crocodile meat, raw conger body and cooked conger body.

Specific IgE was positive for most fish (cod 100, salmon 68, trout 20.6, tuna 2.7, megrim 8.1, sole 41.7, hake 15.4, sardine 5.4, swordfish 1.3 kU/L).

Food challenge: No oral food challenge was performed.

Test with molecules: IgE binding was detected for cod parvalbumin (r Gad c 1, 24.6 kU/L) and in immunoblot, for crocodile parvalbumin Cro p 1.

Conclusion: An anaphylactic reaction to crocodile meat was explained by primary sensitization to fish parvalbumin with cross-reactivity to the crocodile homologue (Figure 194).

Conflict of Interest - MAUG 2.0

S.D. is the Chair of EAACI Scientific Media Communications Committee (til 2022/07) and reports research grants from Euroimmun Labordiagnostika, consulting fees from Leti Pharma, Bencard Allergie GmbH and OMRON Healthcare Technologies Co. Ltd and has received speaker's honoraria from Bencard Allergie GmbH; and Allergopharma and is in the advisory board from Bencard Allergie GmbH.

C.H. is the Chair of Allergy Diagnosis and Systems Medicine Interest Group of EAACI and receives grants from Fonds National de la Recherche, Luxembourg and has a research collaboration with MacroArray Diagnostics; received speaker's honorarium from ALK and travel support from HAL Allergy.

A.F.S. is Chair of the EAACI interest group Food Allergy and has received grants from MRC UK, NIH USA, FARE USA; Asthma UK, Rosetrees Trust, Wellcome Trust, and BBSRC; reports consulting fees from IgGenix, Novartis, Allergy Therapeutics; and Stallergenes; Speaker's honoraria from Novartis, ThermoFisher, Nutricia, Buhlmann, and Nestle and is in the advisory board from Allergy Therapeutics;

N.A. received grant support from the Ministry of Science of the Republic of Colombia (Grants 756-2017, 806-2018) and reports speaker's honorarium from Sanofi at scientific events;

F.A. reports royalties: from Eleva GmbH for patent "fucosyl-transferase" (1999);

B.B-W. reports consulting fees from ALK, Allergopharma, Menarini, Sanofi, Novartis, and Thermofisher; speaker's honoraria from ALK, Allergopharma, Menarini, Sanofi, Novartis, and Thermofisher and is a member of the advisory board from Aimmune;

D.B. reports consulting fees from ALK A/S;

K.B. is board member of: AGATE (Anaphylaxis Training and Education); GPA (German Society for Pediatric Allergology & Environmental Medicine); DGKJ (German Society for Allergology & Clinical Immunology) and DAAB(German Allergy and Asthma Association). She holds research grants from Aimmune, ALK, Danone, DBV, Hipp, Hycor, and Infectopharm; reports consulting fees from Hipp and speaker's honoraria from Aimmune, Danone, Infectopharm, Mylan/meda, Nestle, Novartis, and ThermoFisher; she is a member of the advisory board from Aimmune, Bencard, Danone, DBV, Hycor, Jenapharma, Mylan/Meda, Nestle, and Novartis;

T.B. is the President German Society of Dermatology and reports grants from German Research Foundation (SFB 1371 TP P06; BI 696/12-1); AbbVie, ALK-Abello, Celgene-BMS, and the Lilly, Novartis, Sanofi, Regeneron, Viatrix; consulting fees from ALK-Abello, Lilly, Novartis, and Sanofi; speaker's honoraria from AbbVie, ALK-Abello, Lilly, Novartis, Sanofi, Regeneron; and is a member of the advisory board from LEO Pharma, Lilly, and Sanofi;

S.B. received grants from Thermo Fisher Sci., Bencard Allergie GmbH, Allergy Therapeutics plc, and Leti Pharma; consulting fees from Bencard Allergie GmbH and speaker honoraria from DGAKI, Bencard; Allergie GmbH, and Thermo Fisher Sci.

H.B. reports grant support from Austrian Science Fund (FWF), Danube Allergy Research Cluster funded by the Country of Lower Austria; author Royalties from UpToDate Inc. (Wolters Kluwer

Health); and lecturer's honorarium from Imperial College London, "Allergy Master of Sciences Programme"

He.Bro. is board member of BSACI Paediatric Allergy Group and President Elect of the Royal Society of Medicine; She reports grants from NIH Seal Study and Aimmune; royalties from Wiley Rapid Paediatrics and Speaker's honoraria from DBV Technologies, Sanofi, and GSK; travel support from EAACI, BSACI; and is in the advisory board of SEED Study and IREACH Study;

M.D.C. is co-owner, shareholder and employee of Indoor Biotechnologies;

M.C. reports grant support from R01 NIH grant with INDOOR Biotechnologies;

A.C. is board member of WAO and the British Society of Allergy and Clinical Immunology; he received a grant from MRC (UK): MR/S025340/1; reports consulting fees from Philipps, Worg Pharmaceuticals, Stallergenes-Greer; speaker's honoraria from AstraZeneca, Novartis, and GSK;

R.C. reports grants from Australian NHMRC Aus Pollen Partnership (GNT1116107); Abionic SA (Switzerland) co-funding of collaboration research grant from NFMRI; and patent: US PTO 14/311944 owned by QUT; AU2008/316301 owned by QUT;

A.M.E. reports grants from Nutricia Research, Utrecht, The Netherlands; and Euroimmun AG, Lübeck, Germany;

P.A.E. reports grant support from Ulrich Muller Gierock Foundation; consulting fees from DBV, Nestle, Danone, Novartis, Abbott, Alexeia and ThermoFisher; travel support from EAACI, ThermoFisher; royalties from upToDate; Elsevier; speaker's honoraria from TF, Abbott; ALK; and holds stock options from DBV Technologies;

F.G.P. receives grant support from the Span. Ministry of Economics and Competition: PI17/01318, AC18/00031; RETICS ARADyAL (RD16/0006/0001, RD16/0006/0007); Sen. Clin. Res. Program B-0005-2019;

C.Ha. reports grant support from Danube Allergy Research Cluster funded by Country of Lower Austria; and is a member of the advisory board from Allergios;

R.G. H. is supported by the Johns Hopkins University School of Medicine faculty Scholarship;

T.H. reports speaker's honoraria from ALK, Bencard, Takeda ALK, Novartis, and HAL; travel support from Novartis; and is in the advisory board from Novartis, Bencard, ALK, and Takeda;

H.J.H. is the current treasurer of the Danish Society of Allergology; he reports grant from the Danish Innovation Funds; and is filing Patent 74490PC01; has received travel support from AAAAI;

T.Ho. is advisory board member from Deutscher Allergie- und Asthmabund eV, DAAB; German Federal Office of Consumer Protection and Food Safety; Senate Commission on Food Safety of the German Research Foundation, DFG-SKLM; International Life Sciences Institute, ILSI Europe; received grants from European Dir. for the Quality of Medicines and Health Care; EU-COST Action ImpARAS; German Federal Ministry of Food and Agriculture; and obtained travel support from Food Allergy Forum April,2019, Bastiaanse-communication, Bilthoven, NL;

T.J. is board member of the German Society of Allergy and Clinical Immunology; he has received grants from: ALK Abello, Novartis; speaker's honoraria from ALK Abello, Novartis, Thermo Fisher Sci., and Allergy Therapeutics/Bencard; he is in the advisory board from ALK Abello, Novartis, and Bencard;

U.J. is member of the Scientific Board of the German Society for Allergology and Clinical Immunology (DGAKI); Executive Committee of the WHO/IUIS Allergen Nomenclature Subcommittee; editorial Board Member of the Journal "Allergy." She reports grants from the German Research Foundation: DFG JA 1007/2-3; Federal Ministry of Education and Science: DZL: German Center for Lung Research; AA-FPB;FKZ:01EA2109B; Verbundprojekt ImprovNgDiagnostiCs and Therapy; INDICATE-FH BMEL and BLE AptoSens; has received consulting fees from Fraunhofer Zukunftsstiftung; and files for Patent: Project 14-00142 (Basophil-Activation Test), pending;

M.J. is EAACI President (til 2022/07); reports consulting fees from Allergopharma, Stallergenes, Regeneron, Pfizer, and Chiesi; speaker's honoraria from Stallergenes Greer, Allergopharma, and HAL Allergy; is in the advisory board from Allergopharma and receives clinical Investigator honoraria from GSK, AstraZeneca, Regeneron, Genentech, Takeda, Chiesi, Novartis, Allergopharma, Stallergenes, Allergy Therapeutics, HAL Allergy, ALK Abello, Shire, Celltrion, and Verona Pharma;

J.K-T. is a member of the German Society of Allergy and Clinical Immunology; reports grants from GSK, Lofarma, Novartis, Regeneron, and Stallergenes-Greer; received honoraria from AllergenOnline (Nebraska, USA), Allergy Therapeutics, Allergopharma, ALK-Abelló, AstraZeneca, Bencard, HAL Allergy, LETI, Sanofi, Springer International Publishers, ThermoFisher Sci, and Thieme Publishers, Germany;

E.K. is EAACI Board member and received speaker's honoraria and travel support from ThermoFisher Sci.

J.K. reports speaker's honoraria from ThermoFisher Sci.

G.L. Grants: NIAID, NIH, FARE, Action Medical Research; MRC & Asthma UK Centre, UK Dept of Health through NIHR, National Peanut Board, The Davis Foundation; Consulting fees: DBV, Novartis; ALK Abello, Lurie Children's Hospital; speakers honoraria: DBV, ALK Abello, EPG Health; scientific advisory board member: DBV Technologies; National Peanut Board; Lurie Children's Hospital; stock holder: DBV Technology; shareholder: Mission Mighty Me;

T-M.L. reports speaker's honoraria from ThermoFisher Sci.

O.L. reports consulting fees received from ThermoFisher Sci.; speaker's honoraria from ThermoFisher Sci.; GSK, AstraZeneca; Sanofi, Novartis; WAO; and Vall d'Hebron Research Institute; and travel support from: Sanofi; she is a member of the advisory board from Sanofi and AstraZeneca;

C.M. is nonexecutive Director from Reacta Biotech Ltd until November 2019; Member of the Food Standards Agency Advisory Committee on Novel Foods and Processes; and holds founder shares of Reacta Biotech Ltd; she reports grants from Reacta B UK Research and Innovation - Innovate, Swindon, UK, Biotech Ltd, European Food Safety Authority, Food Standards Agency, London, UK; consultancy fees received from Reacta Biotech Ltd; travel support from Romer Laboratories UK Ltd to attend CIFSQ, Shanghai, China, Dec 2019; and is patent holder Int. Patent Application (PCT); Oral Food

Challenge Meal Formulations—Kit for allergy diagnosis. Application number:PCT/GB2016/051637; Int. Patent application (PCT): Oral Food Challenge Meal Formulations: Kits comprising placebo and nonplacebo oral food challenge meal formulations. Application number: PCT/GB2016/053829;

M.M. is a member of the Food allergy working group of the French Society of Allergology; reports grant support from Novartis; received speaker's honoraria from Stallergenes Greer, Novartis, ALK, and ThermoFisher;

A.M. is GA2LEN Executive Committee member; she reports grants obtained from Aimmune, DVB Technologies, and Novartis; speaker's honoraria from Aimmune, DVB Technologies, Nestlé Health Science, Nestlé Purina, and Viatrix; and is member of the advisory board from Viatrix, Novartis, Aimmune, DVB technologies; and member of the Data safety monitoring board from Regeneron;

A. N-W. is committee member of IFPIES, Annals of Allergy, Asthma and Immunology, and American Board of Allergy and Immunology; received grant support from DBV Technologies, Regeneron, Alladapt; and consulting fees from Aquestive; speaker's honoraria from Nestle, Danone, and ThermoFisher Sci;

M.O. is Vice president of Science EAACI; he reports grant support from Fonds National de la Recherche Luxembourg, consulting fees from Hycor Biomedical; speaker's honoraria from Hycor Biomedical, ThermoFisher Sci. Phadia, consulting fees from the Ministry of Health, Government of Luxembourg; travel support from EAACI for annual congresses; patents pending: WO2019/076478A1; WO2019/076477A1; scientific co-founder of Tolerogenics SARL, Esch-sur-Alzette;

S.P. received grants from National Institutes of Health, NIAID; Food Allergy Science Initiative; and filing of patent: Monoclonal antibody (pending);

A.P. is employed by InBio Inc; she reports grant from NIH Award Number R01AI077653 (to AP); received speaker's honorarium from ThermoFisher Sci.

E.P. reports grant support from Hycor Biomedical;

L.K.P. is board member of the Asthma and Allergy Denmark (Patient organization) and Research Council, CIA (Collegium International Allergologicum); advisory Board Member of COMPARE Allergen Database HESI; reports consulting fees from Novozymes A/S and speaker's honoraria from HVD Holding AG Poland;

C.R. receives grant from the Austrian Science Fund (FWF);

S.R. reports grant support from ITN070AD, (Impact of Ad Libitum Peanut Consumption and Genetics in LEAP Participants and Families: LEAP Participant, Sibling and Parent Cohorts (LEAP Trio)," subaward FY21ITN280 (between Benaroya Research Institute at Virginia Mason and GSTT).

M.R. is executive board member of the German Society for Allergology and Clinical Immunology (DGAKI); member of EAACI interest group IG Envir./Occup. Allergy and member of several task forces; Editor of the Journal "Allergologie/Allergologie Select; received speaker's honoraria from ThermoFisher Sci. and Leti;

J.S. is committee member of SEAIC; EAACI, and AAAAI; reports grant support from Sanofi; and consulting fees from Sanofi, ABBVie; Novartis; speaker's honoraria from Sanofi, GSK, FAES Farma; and travel support from Sanofi;

S.S. received speaker's honorarium from Mylan EPD;

E.S. reports consulting fees and speaker's honoraria from ThermoFisher and Stallergenes;

P. S-G. is treasurer of the Int. Society for Atopic Dermatitis; reports support from Christine Kühne Center for Allergy Research and Education CK-CARE; speaker's honorarium from ThermoFisher; and research collaboration with ThermoFisher, Buehlmann, and Euroimmune.

M.V-M. is advisory board member of Allergy Therapeutics; received speaker's honorarium from GSK; and consulting fees from Organon;

M.vH. received speaker's honorarium from ThermoFisher Sci

R.vR. board member of HESI Protein Allergenicity and Toxins Bioinformatics Committee; holds stock options for Anagany Inc; received grants from Dutch Science Foundation; Health Holland; Angany Inc.; consulting fees from HAL Allergy BV; Citeq Inc., Anagany Inc., Reacta Healthcare Ltd, Mission MightyMe, and AB Enzymes; speaker's honoraria from ThermoFisher Sci. HAL Allergy BV and ALK; travel support from Anagany Inc.

M.W. received consulting fees from DBV, Nestle, Danone, Novartis, Abbott, and Alexeia;

J.Z. reports grant support (Grant 803-2018);

P.M.M. reports grants from Deutsche Forschungsgesellschaft DFG: MA47/2-1; consulting fees from Hycor Biomedical; Euroimmune; ThermoFisher; and speaker's Honorarium from Hycor Biomedical;

K.H-S. is EAACI board member (til 2022/07), receives grant from Danube Allergy Research Cluster funded by Country of Lower Austria; consulting fees for COMPARE allergen database; and speaker's honorarium from EMMA Mtd;

All other authors have no COI to declare.

ORCID

Stephanie Dramburg  <https://orcid.org/0000-0002-9303-3260>

Christiane Hilger  <https://orcid.org/0000-0001-9455-5442>


Alexandra F. Santos  <https://orcid.org/0000-0002-7805-1436>

Leticia de las Vecillas  <https://orcid.org/0000-0003-4969-5678>

Rob C. Aalberse  <https://orcid.org/0000-0002-3902-6596>

Nathalie Acevedo  <https://orcid.org/0000-0002-5154-2964>


Lorenz Aglas  <https://orcid.org/0000-0002-1236-5934>

Friedrich Altmann  <https://orcid.org/0000-0002-0112-7877>


Karla L. Arruda  <https://orcid.org/0000-0002-7505-210X>


Riccardo Asero  <https://orcid.org/0000-0002-8277-1700>


Barbara Ballmer-Weber  <https://orcid.org/0000-0002-4136-5036>


Domingo Barber  <https://orcid.org/0000-0002-5488-5700>


Kirsten Beyer  <https://orcid.org/0000-0003-1859-0419>


Tilo Biedermann  <https://orcid.org/0000-0002-5352-5105>


Maria Beatrice Bilo  <https://orcid.org/0000-0002-9324-6039>

Simon Blank  <https://orcid.org/0000-0002-5649-1078>

Philipp P. Bosshard  <https://orcid.org/0000-0002-1154-2281>

Heimo Breiteneder  <https://orcid.org/0000-0003-2022-8689>

Helen A. Brough  <https://orcid.org/0000-0001-7203-0813>

Merima Bublin  <https://orcid.org/0000-0002-7191-9431>

Dianne Campbell  <https://orcid.org/0000-0002-0907-6963>

Luis Caraballo  <https://orcid.org/0000-0002-5204-1109>

Jean Christoph Caubet  <https://orcid.org/0000-0001-5006-5724>

Martin D. Chapman  <https://orcid.org/0000-0002-0845-3632>

Maksymilian Chruszcz  <https://orcid.org/0000-0001-7521-5485>

Adnan Custovic  <https://orcid.org/0000-0001-5218-7071>

Rebecca Czolk  <https://orcid.org/0000-0003-4296-3051>

Janet Davies  <https://orcid.org/0000-0002-6378-4119>

Nikolaos Douladiris  <https://orcid.org/0000-0003-4037-4421>

Bernadette Eberlein  <https://orcid.org/0000-0003-4509-6491>

Motohiro Ebisawa  <https://orcid.org/0000-0003-4117-558X>

Anna Ehlers  <https://orcid.org/0000-0001-7833-2900>

Philippe Eigenmann  <https://orcid.org/0000-0003-1738-1826>

Gabriele Gadermaier  <https://orcid.org/0000-0002-4886-417X>

Mattia Giovannini  <https://orcid.org/0000-0001-9568-6882>


Francisca Gomez  <https://orcid.org/0000-0003-1607-6686>

Carole Guillet  <https://orcid.org/0000-0003-3809-0526>

Christine Hafner  <https://orcid.org/0000-0003-3745-1414>

Michael Hauser  <https://orcid.org/0000-0001-6558-755X>

Hans Jürgen Hoffmann  <https://orcid.org/0000-0002-6743-7931>

Thomas Holzhauser  <https://orcid.org/0000-0002-7818-7261>

Tomona Iizuka  <https://orcid.org/0000-0002-1946-277X>

Alain Jacquet  <https://orcid.org/0000-0002-0980-9741>

Thilo Jakob  <https://orcid.org/0000-0002-3124-9998>

Bente Janssen-Weets  <https://orcid.org/0000-0003-3379-7792>

Uta Jappe  <https://orcid.org/0000-0001-5602-3672>


Tanja Kalic  <https://orcid.org/0000-0002-9641-0244>

Sandip Kamath  <https://orcid.org/0000-0002-5956-8552>

Sabine Kespohl  <https://orcid.org/0000-0001-7571-1323>

Edward Knol  <https://orcid.org/0000-0001-7368-9820>

André Knulst  <https://orcid.org/0000-0002-1056-3179>


Jon R. Konradsen  <https://orcid.org/0000-0001-7745-8624>

Peter Korošec  <https://orcid.org/0000-0002-0835-1599>

Annette Kuehn  <https://orcid.org/0000-0003-0474-2135>


Gideon Lack  <https://orcid.org/0000-0001-7350-4021>

Thuy-My Le  <https://orcid.org/0000-0001-6571-220X>

Andreas Lopata  <https://orcid.org/0000-0002-2940-9235>

Olga Luengo  <https://orcid.org/0000-0002-8905-2776>

Clare Mills  <https://orcid.org/0000-0001-7433-1740>

Martine Morisset  <https://orcid.org/0000-0002-4028-703X>


Antonella Muraro  <https://orcid.org/0000-0002-5026-5862>


Anna Nowak-Wegrzyn  <https://orcid.org/0000-0002-0960-9854>


Roni Nugraha  <https://orcid.org/0000-0001-5935-5867>


Markus Ollert  <https://orcid.org/0000-0002-8055-0103>


Kati Palosuo  <https://orcid.org/0000-0002-4357-0439>


Elide Anna Pastorello  <https://orcid.org/0000-0002-3753-1783>


Sarita Ulhas Patil  <https://orcid.org/0000-0002-2172-2286>


Thomas Platts-Mills  <https://orcid.org/0000-0002-1263-329X>






Anna Pomés  <https://orcid.org/0000-0002-8729-1829>

Pascal Poncet  <https://orcid.org/0000-0003-0757-5424>

Ekaterina Potapova  <https://orcid.org/0000-0003-4427-6335>

Lars K. Poulsen  <https://orcid.org/0000-0002-1730-847X>

Christian Radauer  <https://orcid.org/0000-0001-9920-4449>

Suzana Radulovic  <https://orcid.org/0000-0003-1154-8365>
 Monika Raulf  <https://orcid.org/0000-0001-6315-120X>
 Pierre Rougé  <https://orcid.org/0000-0002-9936-7843>
 Joaquin Saestre  <https://orcid.org/0000-0003-4689-6837>
 Sakura Sato  <https://orcid.org/0000-0003-3674-0759>
 Enrico Scala  <https://orcid.org/0000-0002-9391-9168>
 Johannes M. Schmid  <https://orcid.org/0000-0002-4558-2943>
 Peter Schmid-Grendelmeier  <https://orcid.org/0000-0003-3215-3370>
 Denise Schrama  <https://orcid.org/0000-0003-0274-5957>
 Hélène Sénéchal  <https://orcid.org/0000-0002-8415-8803>
 Claudia Traidl-Hoffmann  <https://orcid.org/0000-0001-5085-5179>
 Marcela Valverde-Monge  <https://orcid.org/0000-0002-0172-3951>
 Marianne van Hage  <https://orcid.org/0000-0003-3091-1596>
 Ronald van Ree  <https://orcid.org/0000-0003-0767-0894>
 Kitty Verhoeckx  <https://orcid.org/0000-0002-6557-3198>
 Stefan Vieths  <https://orcid.org/0000-0003-3826-6704>
 Magnus Wickman  <https://orcid.org/0000-0003-2710-8620>
 Josefina Zakzuk  <https://orcid.org/0000-0002-6007-5376>
 Paolo M. Matricardi  <https://orcid.org/0000-0001-5485-0324>
 Karin Hoffmann-Sommergruber  <https://orcid.org/0000-0002-8830-058X>

REFERENCES

- Ishizaka K, Ishizaka T. Identification of gamma-E-antibodies as a carrier of reaginic activity. *J Immunol*. 1967;99(6):1187-1198.
- WHO/IUIS Allergen Nomenclature Home Page. Accessed September 4, 2021. <http://allergen.org/>
- IUIS/WHO Allergen Nomenclature Subcommittee. Allergen nomenclature. IUIS/WHO Allergen Nomenclature Subcommittee. *Bull World Health Organ*. 1994;72(5):797-806.
- Matricardi PM, Kleine-Tebbe J, Hoffmann HJ, et al. EAACI molecular allergology user's guide. *Pediatr Allergy Immunol*. 2016;27(Suppl 23):1-250.
- Johnson P, Marsh DG. 'Isoallergens' from rye grass pollen. *Nature*. 1965;206(987):935-937.
- King TP, Norman PS, Connell JT. Isolation and characterization of allergens from ragweed pollen. II. *Biochemistry*. 1964;3:458-468.
- Aas K, Jepsen JW. Studies of hypersensitivity to fish. Partial purification and crystallization of a major allergenic component of cod. *Int Arch Allergy Appl Immunol*. 1967;32(1):1-20.
- Chapman MD, Platts-Mills TA. Purification and characterization of the major allergen from *Dermatophagoides pteronyssinus*-antigen P1. *J Immunol*. 1980;125(2):587-592.
- Radauer C, Nandy A, Ferreira F, et al. Update of the WHO/IUIS Allergen Nomenclature Database based on analysis of allergen sequences. *Allergy*. 2014;69(4):413-419.
- King TP, Hoffman D, Løwenstein H, Marsh DG, Platts-Mills TA, Thomas W. Allergen nomenclature. *Allergy*. 1995;50(9):765-774.
- Ackaert C, Kofler S, Horejs-Hoek J, et al. The impact of nitration on the structure and immunogenicity of the major birch pollen allergen Bet v 1.0101. *PLoS One*. 2014;9(8):e104520.
- Aalberse RC. Recombinant allergens need a reality check. *J Allergy Clin Immunol*. 2022;149(3):901-903.
- Aalberse RC. Structural biology of allergens. *J Allergy Clin Immunol*. 2000;106(2):228-238.
- Aalberse RC, Akkerdaas J, van Ree R. Cross-reactivity of IgE antibodies to allergens. *Allergy*. 2001;56(6):478-490.
- Pascal M, Grishina G, Yang AC, et al. Molecular diagnosis of shrimp allergy: efficiency of several allergens to predict clinical reactivity. *J Allergy Clin Immunol Pract*. 2015;3(4):521-529.
- Aalberse RC, Koshte V, Clemens JG. Immunoglobulin E antibodies that crossreact with vegetable foods, pollen, and Hymenoptera venom. *J Allergy Clin Immunol*. 1981;68(5):356-364.
- Platts-Mills TA, Hilger C, Jappe U, et al. Carbohydrate epitopes currently recognized as targets for IgE antibodies. *Allergy*. 2021;76(8):2383-2394.
- Platts-Mills TA, Schuyler AJ, Tripathi A, Commins SP. Anaphylaxis to the carbohydrate side chain alpha-gal. *Immunol Allergy Clin North Am*. 2015;35(2):247-260.
- van Ree R. Carbohydrate epitopes and their relevance for the diagnosis and treatment of allergic diseases. *Int Arch Allergy Immunol*. 2002;129(3):189-197.
- Platts-Mills TAE, Li RC, Keshavarz B, Smith AR, Wilson JM. Diagnosis and management of patients with the α -Gal syndrome. *J Allergy Clin Immunol Pract*. 2020;8(1):15-23.
- Murangi T, Prakash P, Moreira BP, et al. *Ascaris lumbricoides* and ticks associated with sensitization to galactose α 1,3-galactose and elicitation of the alpha-gal syndrome. *J Allergy Clin Immunol*. 2022;149(2):698-707.
- Aalberse RC, Cramer R. IgE-binding epitopes: a reappraisal. *Allergy*. 2011;66(10):1261-1274.
- Grüber C, Lau S, Dannemann A, Sommerfeld C, Wahn U, Aalberse RC. Down-regulation of IgE and IgG4 antibodies to tetanus toxoid and diphtheria toxoid by covaccination with cellular Bordetella pertussis vaccine. *J Immunol*. 2001;167(4):2411-2417.
- Caraballo L, Valenta R, Acevedo N, Zakzuk J. Are the terms major and minor allergens useful for precision allergology? *Front Immunol*. 2021;12:651500.
- Breiteneder H, Mills EN. Molecular properties of food allergens. *J Allergy Clin Immunol*. 2005;115(1):14-23; quiz 24.
- Virtanen T, Kinnunen T, Rytkönen-Nissinen M. Mammalian lipocalin allergens—insights into their enigmatic allergenicity. *Clin Exp Allergy*. 2012;42(4):494-504.
- Westerhout J, Krone T, Snippe A, et al. Allergenicity prediction of novel and modified proteins: not a mission impossible! Development of a Random Forest allergenicity prediction model. *Regul Toxicol Pharmacol*. 2019;107:104422.
- Posa D, Perna S, Resch Y, et al. Evolution and predictive value of IgE responses toward a comprehensive panel of house dust mite allergens during the first 2 decades of life. *J Allergy Clin Immunol*. 2017;139(2):541-549.
- Sarzsinszky E, Lupinek C, Vrtala S, et al. Expression in *Escherichia coli* and purification of folded rDer p 20, the arginine kinase from *Dermatophagoides pteronyssinus*: a possible biomarker for allergic asthma. *Allergy Asthma Immunol Res*. 2021;13(1):154-163.
- Siroux V, Boudier A, Nadif R, Lupinek C, Valenta R, Bousquet J. Association between asthma, rhinitis, and conjunctivitis multimorbidities with molecular IgE sensitization in adults. *Allergy*. 2019;74(4):824-827.
- Nicolaou N, Poorafshar M, Murray C, et al. Allergy or tolerance in children sensitized to peanut: prevalence and differentiation using component-resolved diagnostics. *J Allergy Clin Immunol*. 2010;125(1):191-197.
- Vieths S, Scheurer S, Ballmer-Weber B. Current understanding of cross-reactivity of food allergens and pollen. *Ann N Y Acad Sci*. 2002;964:47-68.
- Sancho AI, Wangorsch A, Jensen BM, et al. Responsiveness of the major birch allergen Bet v 1 scaffold to the gastric environment: impact on structure and allergenic activity. *Mol Nutr Food Res*. 2011;55(11):1690-1699.
- Reuter A, Lidholm J, Andersson K, et al. A critical assessment of allergen component-based in vitro diagnosis in cherry allergy across Europe. *Clin Exp Allergy*. 2006;36(6):815-823.

35. Skypala IJ, Asero R, Barber D, et al. Non-specific lipid-transfer proteins: allergen structure and function, cross-reactivity, sensitization, and epidemiology. *Clin Transl Allergy*. 2021;11(3):e12010.
36. Fernández-Rivas M, Bolhaar S, González-Mancebo E, et al. Apple allergy across Europe: how allergen sensitization profiles determine the clinical expression of allergies to plant foods. *J Allergy Clin Immunol*. 2006;118(2):481-488.
37. Asero R. In patients with LTP syndrome food-specific IgE show a predictable hierarchical order. *Eur Ann Allergy Clin Immunol*. 2014;46(4):142-146.
38. Smole U, Gour N, Phelan J, et al. Serum amyloid A is a soluble pattern recognition receptor that drives type 2 immunity. *Nat Immunol*. 2020;21(7):756-765.
39. Brusilovsky M, Rochman M, Rochman Y, et al. Environmental allergens trigger type 2 inflammation through ripoptosome activation. *Nat Immunol*. 2021;22(10):1316-1326.
40. Jacquet A, Robinson C. Proteolytic, lipidergic and polysaccharide molecular recognition shape innate responses to house dust mite allergens. *Allergy*. 2020;75(1):33-53.
41. Coffman RL, Ohara J, Bond MW, Carty J, Zlotnik A, Paul WE. B cell stimulatory factor-1 enhances the IgE response of lipopolysaccharide-activated B cells. *J Immunol*. 1986;136(12):4538-4541.
42. Paul WE. History of interleukin-4. *Cytokine*. 2015;75(1):3-7.
43. Masthoff LJ, Mattsson L, Zuidmeer-Jongejan L, et al. Sensitization to Cor a 9 and Cor a 14 is highly specific for a hazelnut allergy with objective symptoms in Dutch children and adults. *J Allergy Clin Immunol*. 2013;132(2):393-399.
44. Datema MR, Zuidmeer-Jongejan L, Asero R, et al. Hazelnut allergy across Europe dissected molecularly: a EuroPrevall outpatient clinic survey. *J Allergy Clin Immunol*. 2015;136(2):382-391.
45. Datema MR, van Ree R, Asero R, et al. Component-resolved diagnosis and beyond: Multivariable regression models to predict severity of hazelnut allergy. *Allergy*. 2018;73(3):549-559.
46. Lyons SA, Datema MR, Le TM, et al. Walnut allergy across Europe: distribution of allergen sensitization patterns and prediction of severity. *J Allergy Clin Immunol Pract*. 2021;9(1):225-235.
47. Aalberse RC. Assessment of allergen cross-reactivity. *Clin Mol Allergy*. 2007;5:2.
- 48a. van Ree R, Voitenko V, van Leeuwen WA, Aalberse RC. Profilin is a cross-reactive allergen in pollen and vegetable foods. *Int Arch Allergy Immunol*. 1992;98(2):97-104.
- 48b. Valenta R, Duchêne M, Pettenburger K, et al. Identification of profilin as a novel pollen allergen; IgE autoreactivity in sensitized individuals. *Science*. 1991;253(5019):557-560.
49. Witteman AM, Akkerdaas JH, van Leeuwen J, van der Zee JS, Aalberse RC. Identification of a cross-reactive allergen (presumably tropomyosin) in shrimp, mite and insects. *Int Arch Allergy Immunol*. 1994;105(1):56-61.
- 50a. Altmann F. The role of protein glycosylation in allergy. *Int Arch Allergy Immunol*. 2007;142(2):99-115.
- 50b. Calkhoven PG, Aalbers M, Koshte VL, Pos O, Oei HD, Aalberse RC. Cross-reactivity among birch pollen, vegetables and fruits as detected by IgE antibodies is due to at least three distinct cross-reactive structures. *Allergy*. 1987;42(5):382-390.
51. van der Veen MJ, van Ree R, Aalberse RC, et al. Poor biologic activity of cross-reactive IgE directed to carbohydrate determinants of glycoproteins. *J Allergy Clin Immunol*. 1997;100(3):327-334.
52. Santos A, van Ree R. Profilins: mimickers of allergy or relevant allergens? *Int Arch Allergy Immunol*. 2011;155(3):191-204.
53. Mari A, Ooievaar-de Heer P, Scala E, et al. Evaluation by double-blind placebo-controlled oral challenge of the clinical relevance of IgE antibodies against plant glycans. *Allergy*. 2008;63(7):891-896.
54. Santos AF, Alpan O, Hoffmann HJ. Basophil activation test: Mechanisms and considerations for use in clinical trials and clinical practice. *Allergy*. 2021;76(8):2420-2432.
55. Caraballo L, Valenta R, Puerta L, et al. The allergenic activity and clinical impact of individual IgE-antibody binding molecules from indoor allergen sources. *World Allergy Organ J*. 2020;13(5):100118.
56. Järvinen KM, Beyer K, Vila L, Bardina L, Mishoe M, Sampson HA. Specificity of IgE antibodies to sequential epitopes of hen's egg ovomucoid as a marker for persistence of egg allergy. *Allergy*. 2007;62(7):758-765.
57. Agabriel C, Ghazouani O, Birnbaum J, et al. Ara h 2 and Ara h 6 sensitization predicts peanut allergy in Mediterranean pediatric patients. *Pediatr Allergy Immunol*. 2014;25(7):662-667.
58. Skamstrup Hansen K, Poulsen LK. Component resolved testing for allergic sensitization. *Curr Allergy Asthma Rep*. 2010;10(5):340-348.
59. Aalberse JA, Aalberse RC. A lesson from component-resolved testing: we need better extracts. *J Allergy Clin Immunol Pract*. 2014;2(5):635-636.
60. Akkerdaas J, Finkina EI, Balandin SV, et al. Lentil (Lens culinaris) lipid transfer protein Len c 3: a novel legume allergen. *Int Arch Allergy Immunol*. 2012;157(1):51-57.
61. Akkerdaas JH, Wensing M, Knulst AC, et al. How accurate and safe is the diagnosis of hazelnut allergy by means of commercial skin prick test reagents? *Int Arch Allergy Immunol*. 2003;132(2):132-140.
62. Zuidmeer-Jongejan L, Fernández-Rivas M, Winter MG, et al. Oil body-associated hazelnut allergens including oleosins are under-represented in diagnostic extracts but associated with severe symptoms. *Clin Transl Allergy*. 2014;4(1):4.
63. Bolhaar ST, Zuidmeer L, Ma Y, et al. A mutant of the major apple allergen, Mal d 1, demonstrating hypo-allergenicity in the target organ by double-blind placebo-controlled food challenge. *Clin Exp Allergy*. 2005;35(12):1638-1644.
64. Kollmann D, Geroldinger-Simic M, Kinaciyan T, et al. Recombinant Mal d 1 is a reliable diagnostic tool for birch pollen allergen-associated apple allergy. *J Allergy Clin Immunol*. 2013;132(4):1008-1010.
65. Kinaciyan T, Nagl B, Faustmann S, et al. Efficacy and safety of 4 months of sublingual immunotherapy with recombinant Mal d 1 and Bet v 1 in patients with birch pollen-related apple allergy. *J Allergy Clin Immunol*. 2018;141(3):1002-1008.
66. Valenta R, Lidholm J, Niederberger V, Hayek B, Kraft D, Grönlund H. The recombinant allergen-based concept of component-resolved diagnostics and immunotherapy (CRD and CRIT). *Clin Exp Allergy*. 1999;29(7):896-904.
67. Werfel T, Asero R, Ballmer-Weber BK, et al. Position paper of the EAACI: food allergy due to immunological cross-reactions with common inhalant allergens. *Allergy*. 2015;70(9):1079-1090.
68. Heinzerling L, Mari A, Bergmann KC, et al. The skin prick test – European standards. *Clin Transl Allergy*. 2013;3(1):3.
69. Hamilton RG, Matsson PNJ, Chan S, et al. *Analytical Performance Characteristics, Quality Assurance and Clinical Utility of Immunological ASSAYS FOR Human Immunoglobulin E (IgE) Antibodies of Defined Allergen Specificities*. Third ed. I/LA20-A3, International CLSIGuideline; 2016. Accessed February 8, 2022. <https://clsi.org/standards/products/immunology-and-ligand-assay/documents/i-la20/>.
70. Pascal M, Moreno C, Dávila I, et al. Integration of in vitro allergy test results and ratio analysis for the diagnosis and treatment of allergic patients (INTEGRA). *Clin Transl Allergy*. 2021;11(7):e12052.
71. Chapman MD, Wuenschmann S, King E, Pomés A. Technological innovations for high-throughput approaches to in vitro allergy diagnosis. *Curr Allergy Asthma Rep*. 2015;15(7):36.
72. Agache I, Bilò M, Braunstahl GJ, et al. In vivo diagnosis of allergic diseases—allergen provocation tests. *Allergy*. 2015;70(4):355-365.
73. Muraro A, Werfel T, Hoffmann-Sommergruber K, et al. EAACI food allergy and anaphylaxis guidelines: diagnosis and management of food allergy. *Allergy*. 2014;69(8):1008-1025.

74. Sampson HA, Aceves S, Bock SA, et al. Food allergy: a practice parameter update-2014. *J Allergy Clin Immunol*. 2014;134(5):1016-1025.
75. Ansley L, Bonini M, Delgado L, et al. Pathophysiological mechanisms of exercise-induced anaphylaxis: an EAACI position statement. *Allergy*. 2015;70(10):1212-1221.
76. Bianchi A, Tsilochristou O, Gabrielli F, Tripodi S, Matricardi PM. The smartphone: a novel diagnostic tool in pollen allergy? *J Invest Allergol Clin Immunol*. 2016;26(3):204-207.
77. Hoffmann TM, Acar Şahin A, Aggelidis X, et al. "Whole" vs. "fragmented" approach to EAACI pollen season definitions: a multicenter study in six Southern European cities. *Allergy*. 2020;75(7):1659-1671.
78. Incorvaia C, Mauro M, Ridolo E, Makri E, Montagni M, Ciprandi G. A pitfall to avoid when using an allergen microarray: the incidental detection of IgE to unexpected allergens. *J Allergy Clin Immunol Pract*. 2015;3(6):879-882.
79. Giangrieco I, Rifaiani C, Liso M, et al. Allergens in allergy diagnosis: a glimpse at emerging new concepts and methodologies. *Transl Med UniSa*. 2012;4:27-33.
80. Lyons JJ, Milner JD. Primary atopic disorders. *J Exp Med*. 2018;215(4):1009-1022.
81. Valenta R, Twaroch T, Swoboda I. Component-resolved diagnosis to optimize allergen-specific immunotherapy in the Mediterranean area. *J Invest Allergol Clin Immunol*. 2007;17(Suppl 1):36-40.
82. Stringari G, Tripodi S, Caffarelli C, et al. The effect of component-resolved diagnosis on specific immunotherapy prescription in children with hay fever. *J Allergy Clin Immunol*. 2014;134(1):75-81.
83. Moreno C, Justicia JL, Quiralte J, et al. Olive, grass or both? Molecular diagnosis for the allergen immunotherapy selection in polysensitized pollinic patients. *Allergy*. 2014;69(10):1357-1363.
84. Tripodi S, Frediani T, Lucarelli S, et al. Molecular profiles of IgE to *Phleum pratense* in children with grass pollen allergy: implications for specific immunotherapy. *J Allergy Clin Immunol*. 2012;129(3):834-839.
85. Cipriani F, Mastroianni C, Tripodi S, et al. Diagnostic relevance of IgE sensitization profiles to eight recombinant *Phleum pratense* molecules. *Allergy*. 2018;73(3):673-682.
86. Darsow U, Brockow K, Pfab F, et al. Allergens. Heterogeneity of molecular sensitization profiles in grass pollen allergy—implications for immunotherapy? *Clin Exp Allergy*. 2014;44(5):778-786.
87. Köhler J, Blank S, Müller S, et al. Component resolution reveals additional major allergens in patients with honeybee venom allergy. *J Allergy Clin Immunol*. 2014;133(5):1383-1389, 1389.e1381-1386.
88. Focke M, Marth K, Valenta R. Molecular composition and biological activity of commercial birch pollen allergen extracts. *Eur J Clin Invest*. 2009;39(5):429-436.
89. Löwenstein H. Characterization and standardization of allergen extracts. *Chem Immunol Allergy*. 2014;100:323-332.
90. Focke M, Marth K, Flicker S, Valenta R. Heterogeneity of commercial timothy grass pollen extracts. *Clin Exp Allergy*. 2008;38(8):1400-1408.
91. European Directorate for the Quality of Medicines (EDQM). *Allergen Products—Pro-Ducta Allergenica. European Pharmacopoeia*. 6th ed. Council of Europe; 2010:679-680.
92. Wojtalewicz N, Goseberg S, Kabrodt K, Schellenberg I. Six years of INSTAND e. V. sIgE proficiency testing: An evaluation of in vitro allergy diagnostics. *Allergo J Int*. 2017;26(2):43-52.
93. Gadermaier E, Staikuniene J, Scheiblhofer S, et al. Recombinant allergen-based monitoring of antibody responses during injection grass pollen immunotherapy and after 5 years of discontinuation. *Allergy*. 2011;66(9):1174-1182.
94. Rossi RE, Monasterolo G, Coco G, Silvestro L, Operti D. Evaluation of serum IgG4 antibodies specific to grass pollen allergen components in the follow up of allergic patients undergoing subcutaneous and sublingual immunotherapy. *Vaccine*. 2007;25(5):957-964.
95. Matricardi PM. Allergen-specific immunoprophylaxis: toward secondary prevention of allergic rhinitis? *Pediatr Allergy Immunol*. 2014;25(1):15-18.
96. Arroabarren E, Echechipía S, Galbete A, Lizaso MT, Olaguibel JM, Tabar AI. Association between component-resolved diagnosis of house dust mite allergy and efficacy and safety of specific immunotherapy. *J Invest Allergol Clin Immunol*. 2019;29(2):164-167.
97. Rodríguez-Domínguez A, Berings M, Rohrbach A, et al. Molecular profiling of allergen-specific antibody responses may enhance success of specific immunotherapy. *J Allergy Clin Immunol*. 2020;146(5):1097-1108.
98. Ruiz B, Serrano P, Moreno C. IgE-Api m 4 is useful for identifying a particular phenotype of bee venom allergy. *J Invest Allergol Clin Immunol*. 2016;26(6):355-361.
99. Blank S, Seismann H, Michel Y, et al. Api m 10, a genuine *A. mellifera* venom allergen, is clinically relevant but underrepresented in therapeutic extracts. *Allergy*. 2011;66(10):1322-1329.
100. Blank S, Etzold S, Darsow U, et al. Component-resolved evaluation of the content of major allergens in therapeutic extracts for specific immunotherapy of honeybee venom allergy. *Hum Vaccin Immunother*. 2017;13(10):2482-2489.
101. Frick M, Fischer J, Helbling A, et al. Predominant Api m 10 sensitization as risk factor for treatment failure in honey bee venom immunotherapy. *J Allergy Clin Immunol*. 2016;138(6):1663-1671.
102. Hamilton RGMP, Mattsson P, Chan S, et al. Analytical performance characteristics, quality assurance and clinical utility of immunological assays for human immunoglobulin E (IgE) antibodies of defined allergen specificities. Third ed. I/LA20-A3, International CLSI-Guideline; 2016 Accessed January 10, 2022. https://clsi.org/media/1414/ila20ed3_sample.pdf.
103. Ekins RP. Ligand assays: from electrophoresis to miniaturized microarrays. *Clin Chem*. 1998;44(9):2015-2030.
104. Ricci G, Capelli M, Miniario R, et al. A comparison of different allergometric tests, skin prick test, Pharmacia UniCAP and ADVIA Centaur, for diagnosis of allergic diseases in children. *Allergy*. 2003;58(1):38-45.
105. Petersen AB, Gudmann P, Milvang-Grønager P, et al. Performance evaluation of a specific IgE assay developed for the ADVIA centaur immunoassay system. *Clin Biochem*. 2004;37(10):882-892.
106. Thorpe SJ, Heath A, Fox B, Patel D, Egner W. The 3rd International Standard for serum IgE: international collaborative study to evaluate a candidate preparation. *Clin Chem Lab Med*. 2014;52(9):1283-1289.
107. Ownby DR, Adkinson NF, Hamilton RG, et al. Multi-centre comparison of ABBOTT MATRIX Aero to Pharmacia Standard RAST, Modified RAST and skin puncture tests. *Eur J Clin Chem Clin Biochem*. 1994;32(8):631-637.
108. Merrett J, Merrett TG. Phadiatop—a novel IgE antibody screening test. *Clin Allergy*. 1987;17(5):409-416.
109. Szeffler SJ, Wenzel S, Brown R, et al. Asthma outcomes: biomarkers. *J Allergy Clin Immunol*. 2012;129(3 Suppl):S9-S23.
110. Hamilton RG, MacGlashan DW Jr, Saini SS. IgE antibody-specific activity in human allergic disease. *Immunol Res*. 2010;47(1-3):273-284.
111. Sereme Y, Casanovas N, Michel M, et al. IgG removal significantly enhances detection of microarray allergen-specific IgE reactivity in patients' serum. *Allergy*. 2021;76(1):395-398.
112. Lupinek C, Wollmann E, Baar A, et al. Advances in allergen-microarray technology for diagnosis and monitoring of allergy: the MeDALL allergen-chip. *Methods*. 2014;66(1):106-119.
113. Hedlin G, Moreno C, Petersson CJ, et al. Allergy diagnosis in children and adults: performance of a new point-of-care device, immunoCAP rapid. *World Allergy Organ J*. 2009;2(7):138-143.

114. Roethlisberger S, Karoui O, Mapelli D, et al. Novel nanofluidic IgE assay versus a reference method: a real-world comparison. *Int Arch Allergy Immunol*. 2019;180(1):28-36.
115. Vieths S, Hoffmann-Sommergruber K. EuroPrevall food allergen library. *Mol Nutr Food Res*. 2008;52(Suppl 2):S157-S158.
116. Hiller R, Laffer S, Harwanegg C, et al. Microarrayed allergen molecules: diagnostic gatekeepers for allergy treatment. *FASEB J*. 2002;16(3):414-416.
117. Martínez-Aranguren R, Lizaso MT, Goikoetxea MJ, et al. Is the determination of specific IgE against components using ISAC 112 a reproducible technique? *PLoS One*. 2014;9(2):e88394.
118. Jakob T, Forstenlechner P, Matricardi P, Kleine-Tebbe J. Molecular allergy diagnostics using multiplex assays: methodological and practical considerations for use in research and clinical routine: Part 21 of the Series Molecular Allergology. *Allergo J Int*. 2015;24:320-332.
119. Huss-Marp J, Gutermuth J, Schäffner I, et al. Comparison of molecular and extract-based allergy diagnostics with multiplex and singleplex analysis. *Allergo J Int*. 2015;24:46-53.
120. Hamilton RG. Multiplex IgE antibody testing as a tool for diagnosis and defining the allergic (atopic) status of study populations. *Arb Paul Ehrlich Inst Bundesinstitut Impfstoffe Biomed Arzneimittel Langen Hess*. 2013;97:82-90.
121. Quan PL, Sabatè-Brescó M, D'Amelio CM, et al. Validation of a commercial allergen microarray platform for specific immunoglobulin E detection of respiratory and plant food allergens. *Ann Allergy Asthma Immunol*. 2022;128(3):283-290.e284.
122. Di Fraia M, Arasi S, Castelli S, et al. A new molecular multiplex IgE assay for the diagnosis of pollen allergy in Mediterranean countries: a validation study. *Clin Exp Allergy*. 2019;49(3):341-349.
123. Keshavarz B, Platts-Mills TAE, Wilson JM. The use of microarray and other multiplex technologies in the diagnosis of allergy. *Ann Allergy Asthma Immunol*. 2021;127(1):10-18.
124. Williams P, Önell A, Baldracchini F, Hui V, Jolles S, El-Shanawany T. Evaluation of a novel automated allergy microarray platform compared with three other allergy test methods. *Clin Exp Immunol*. 2016;184(1):1-10.
125. Wiltshire S, O'Malley S, Lambert J, et al. Detection of multiple allergen-specific IgEs on microarrays by immunoassay with rolling circle amplification. *Clin Chem*. 2000;46(12):1990-1993.
126. Feyzkhanova GU, Filippova MA, Talibov VO, et al. Development of hydrogel biochip for in vitro allergy diagnostics. *J Immunol Methods*. 2014;406:51-57.
127. Renault NK, Gaddipati SR, Wulfert F, et al. Multiple protein extract microarray for profiling human food-specific immunoglobulins A, M, G and E. *J Immunol Methods*. 2011;364(1-2):21-32.
128. Joshi AA, Pecuh MW, Kumar CV, Rusling JF. Ultrasensitive carbohydrate-peptide SPR imaging microarray for diagnosing IgE mediated peanut allergy. *Analyst*. 2014;139(22):5728-5733.
129. King EM, Vailes LD, Tsay A, Satinover SM, Chapman MD. Simultaneous detection of total and allergen-specific IgE by using purified allergens in a fluorescent multiplex array. *J Allergy Clin Immunol*. 2007;120(5):1126-1131.
130. Bastarache JA, Koyama T, Wickersham NE, Ware LB. Validation of a multiplex electrochemiluminescent immunoassay platform in human and mouse samples. *J Immunol Methods*. 2014;408:13-23.
131. Millen JLM, Willems I, Slingers G, Raes M, Koppen G, Langie SAS. Diagnostic characterization of respiratory allergies by means of a multiplex immunoassay. *Clin Exp Immunol*. 2021;203(2):183-193.
132. Chinnasamy T, Segerink LI, Nystrand M, Gantelius J, Andersson Svahn H. Point-of-care vertical flow allergen microarray assay: proof of concept. *Clin Chem*. 2014;60(9):1209-1216.
133. Kim SR, Park KH, Lee JH, et al. Validation of PROTIA™ allergy-Q 64 atopy® as a specific IgE measurement assay for 10 major allergen components. *Allergy Asthma Immunol Res*. 2019;11(3):422-432.
134. McKenzie CI, Varese N, Aui PM, et al. CytoBas: precision component-resolved diagnostics for allergy using flow cytometric staining of basophils with recombinant allergen tetramers. *Allergy*. 2021;76(10):3028-3040.
135. Monaco DR, Sie BM, Nirschl TR, et al. Profiling serum antibodies with a pan allergen phage library identifies key wheat allergy epitopes. *Nat Commun*. 2021;12(1):379.
136. Vila L, Beyer K, Järvinen KM, Chatchatee P, Bardina L, Sampson HA. Role of conformational and linear epitopes in the achievement of tolerance in cow's milk allergy. *Clin Exp Allergy*. 2001;31(10):1599-1606.
137. Beyer K, Ellman-Grunther L, Järvinen KM, Wood RA, Hourihane J, Sampson HA. Measurement of peptide-specific IgE as an additional tool in identifying patients with clinical reactivity to peanuts. *J Allergy Clin Immunol*. 2003;112(1):202-207.
138. Shreffler WG, Lencer DA, Bardina L, Sampson HA. IgE and IgG4 epitope mapping by microarray immunoassay reveals the diversity of immune response to the peanut allergen, Ara h 2. *J Allergy Clin Immunol*. 2005;116(4):893-899.
139. Suprun M, Getts R, Grishina G, Tsuang A, Suárez-Fariñas M, Sampson HA. Ovomucoid epitope-specific repertoire of IgE, IgG(4), IgG(1), IgA(1), and IgD antibodies in egg-allergic children. *Allergy*. 2020;75(10):2633-2643.
140. Suárez-Fariñas M, Suprun M, Kearney P, et al. Accurate and reproducible diagnosis of peanut allergy using epitope mapping. *Allergy*. 2021;76(12):3789-3797.
141. Suprun M, Sicherer SH, Wood RA, et al. Mapping sequential IgE-binding epitopes on major and minor egg allergens. *Int Arch Allergy Immunol*. 2022;183(3):249-261.
142. Matricardi PM, Dramburg S, Skevaki C, Renz H. "Molecular extracts" for allergy diagnostics and therapy. *Pediatr Allergy Immunol*. 2019;30(1):55-58.
143. Sicherer SH, Dhillon G, Laughery KA, Hamilton RG, Wood RA. Caution: the Phadia hazelnut ImmunoCAP (f17) has been supplemented with recombinant Cor a 1 and now detects Bet v 1-specific IgE, which leads to elevated values for persons with birch pollen allergy. *J Allergy Clin Immunol*. 2008;122:413-414.
144. Heiss S, Mahler V, Steiner R, et al. Component-resolved diagnosis (CRD) of type I allergy with recombinant grass and tree pollen allergens by skin testing. *J Invest Dermatol*. 1999;113(5):830-837.
145. Kleine-Tebbe J, Jakob T. *Molecular Allergy Diagnostics: Innovation for a Better Patient Management*. Springer; 2017.
146. Sudharson S, Kalic T, Hafner C, Breiteneder H. Newly defined allergens in the WHO/UIIS Allergen Nomenclature Database during 01/2019-03/2021. *Allergy*. 2021;76(11):3359-3373.
147. Breiteneder H. Allergen families and databases, Chapter A06, pgs39-52. *Pediatr Allergy Immunol*. 2016;27(suppl23):1-250.
148. Hamilton RG. Allergic sensitization is a key risk factor for but not synonymous with allergic disease. *J Allergy Clin Immunol*. 2014;134(2):360-361.
149. Hamilton RGKT, Magnusson C, et al. The DADB: a database of diagnostic IgE antibody assay based allergens (CLSI IL/A 37). *J Allergy Clin Immunol Pract*. 2022.
150. Beyer K, Grabenhenrich L, Härtl M, et al. Predictive values of component-specific IgE for the outcome of peanut and hazelnut food challenges in children. *Allergy*. 2015;70(1):90-98.
151. Kleine-Tebbe J, Jakob T. Molecular allergy diagnostics using IgE singleplex determinations: methodological and practical considerations for use in clinical routine: Part 18 of the Series Molecular Allergology. *Allergo J Int*. 2015;24:185-197.
152. Adkinson NF Jr, Hamilton RG. Clinical history-driven diagnosis of allergic diseases: utilizing in vitro IgE testing. *J Allergy Clin Immunol Pract*. 2015;3(6):871-876; quiz 877-878.

153. Knol EF. Requirements for effective IgE cross-linking on mast cells and basophils. *Mol Nutr Food Res*. 2006;50(7):620-624.
154. MacGlashan DW Jr. Basophil activation testing. *J Allergy Clin Immunol*. 2013;132(4):777-787.
155. Knol EF, Mul FP, Jansen H, Calafat J, Roos D. Monitoring human basophil activation via CD63 monoclonal antibody 435. *J Allergy Clin Immunol*. 1991;88(3 Pt 1):328-338.
156. Hoffmann HJ, Santos AF, Mayorga C, et al. The clinical utility of basophil activation testing in diagnosis and monitoring of allergic disease. *Allergy*. 2015;70(11):1393-1405.
157. Eberlein-König B, Varga R, Mempel M, Darsow U, Behrendt H, Ring J. Comparison of basophil activation tests using CD63 or CD203c expression in patients with insect venom allergy. *Allergy*. 2006;61(9):1084-1085.
158. Sturm GJKB, Sturm GJKB, Sturm EM, et al. The basophil activation test in the diagnosis of allergy: technical issues and critical factors. *Allergy*. 2009;64(9):1319-1326. doi:10.1111/j.1398-9995.2009.02004.x8
159. Regan JA, Cao Y, Dispenza MC, et al. Ibrutinib, a Bruton's tyrosine kinase inhibitor used for treatment of lymphoproliferative disorders, eliminates both aeroallergen skin test and basophil activation test reactivity. *J Allergy Clin Immunol*. 2017;140(3):875-879.e871.
160. Korosec P, Turner PJ, Silar M, et al. Basophils, high-affinity IgE receptors, and CCL2 in human anaphylaxis. *J Allergy Clin Immunol*. 2017;140(3):750-758.e715.
161. Vantur RRM, Koren A, et al. Chemokines during anaphylaxis: the importance of CCL2 and CCL2-dependent chemotactic activity for basophils. *Clin Transl Allergy*. 2020;10(1):63. doi:10.1186/s13601-020-00367-2
162. Schmid JM, Würtzen PA, Dahl R, Hoffmann HJ. Early improvement in basophil sensitivity predicts symptom relief with grass pollen immunotherapy. *J Allergy Clin Immunol*. 2014;134(3):741-744.e745.
163. Schmid JMWP, Siddhuraj P, et al. Basophil sensitivity reflects long-term clinical outcome of subcutaneous immunotherapy in grass pollen-allergic patients. *Allergy*. 2021;76(5):1528-1538. doi:10.1111/all.14264
164. Alpan O, Layhadi JA, Ulrik Sønder S, Li H, Shamji MH. Basophil activation test: A diagnostic, predictive and monitoring assay for allergen immunotherapy. *Allergy*. 2021;76(5):1321-1324.
165. Pichler WJ. The p-i Concept: Pharmacological Interaction of Drugs With Immune Receptors. *World Allergy Organ J*. 2008;1(6):96-102.
166. Hennesdorf F, Florian S, Jakob A, et al. Identification of CD13, CD107a, and CD164 as novel basophil-activation markers and dissection of two response patterns in time kinetics of IgE-dependent upregulation. *Cell Res*. 2005;15(5):325-335.
167. Bühring HJ, Streble A, Valent P. The basophil-specific ectoenzyme E-NPP3 (CD203c) as a marker for cell activation and allergy diagnosis. *Int Arch Allergy Immunol*. 2004;133(4):317-329.
168. Puan KJ, Andiappan AK, Lee B, et al. Systematic characterization of basophil anergy. *Allergy*. 2017;72(3):373-384.
169. Foong RX, Dantzer JA, Wood RA, Santos AF. Improving Diagnostic Accuracy in Food Allergy. *J Allergy Clin Immunol Pract*. 2021;9(1):71-80.
170. Hemmings O, Niazi U, Kwok M, James LK, Lack G, Santos AF. Peanut diversity and specific activity are the dominant IgE characteristics for effector cell activation in children. *J Allergy Clin Immunol*. 2021;148(2):495-505.e414.
171. Eberlein B. Basophil Activation as Marker of Clinically Relevant Allergy and Therapy Outcome. *Front Immunol*. 2020;11:1815.
172. Ebo DG, Hagendorens MM, Bridts CH, Schuerwegh AJ, De Clerck LS, Stevens WJ. Flow cytometric analysis of in vitro activated basophils, specific IgE and skin tests in the diagnosis of pollen-associated food allergy. *Cytometry B Clin Cytom*. 2005;64(1):28-33.
173. Decuyper II, Pascal M, Van Gasse AL, et al. Performance of basophil activation test and specific IgG4 as diagnostic tools in nonspecific lipid transfer protein allergy: Antwerp-Barcelona comparison. *Allergy*. 2020;75(3):616-624.
174. Franz-Oberdorf K, Eberlein B, Edelmann K, et al. Fra a 1.02 Is the Most Potent Isoform of the Bet v 1-like Allergen in Strawberry Fruit. *J Agric Food Chem*. 2016;64(18):3688-3696.
175. Palacín A, Tordesillas L, Gamboa P, et al. Characterization of peach thaumatin-like proteins and their identification as major peach allergens. *Clin Exp Allergy*. 2010;40(9):1422-1430.
176. Santos AF, Douiri A, Bécares N, et al. Basophil activation test discriminates between allergy and tolerance in peanut-sensitized children. *J Allergy Clin Immunol*. 2014;134(3):645-652.
177. Van Erp FC, Knol EF, et al. The IgE and basophil responses to Ara h 2 and Ara h 6 are good predictors of peanut allergy in children. *J Allergy Clin Immunol*. 2017; Jan;139(1):358-360. doi:10.1016/j.jaci.2016.06.041
178. Santos AF, Bergmann M, Brough HA, et al. Basophil Activation Test Reduces Oral Food Challenges to Nuts and Sesame. *J Allergy Clin Immunol Pract*. 2021;9(5):2016-2027.e2016.
179. Santos AFLG. Basophil activation test: food challenge in a test tube or specialist research tool? *Clin Transl Allergy*. 2016;6:10. doi:10.1186/s13601-016-0098-7
180. Mehlich J, Fischer J, Hilger C, et al. The basophil activation test differentiates between patients with alpha-gal syndrome and asymptomatic alpha-gal sensitization. *J Allergy Clin Immunol*. 2019;143(1):182-189.
181. Rubio A, Vivinus-Nébot M, Bourrier T, Saggio B, Albertini M, Bernard A. Benefit of the basophil activation test in deciding when to reintroduce cow's milk in allergic children. *Allergy*. 2011;66(1):92-100.
182. Jones SM, Pons L, Roberts JL, et al. Clinical efficacy and immune regulation with peanut oral immunotherapy. *J Allergy Clin Immunol*. 2009;124(2):292-300. 300.e291-297.
183. Gamboa PM, Garcia-Lirio E, Gonzalez C, Gonzalez A, Martinez-Aranguren RM, Sanz ML. Is the Quantification of Antigen-Specific Basophil Activation a Useful Tool for Monitoring Oral Tolerance Induction in Children With Egg Allergy? *J Investig Allergol Clin Immunol*. 2016;26(1):25-30.
184. Thyagarajan A, Jones SM, Calatroni A, et al. Evidence of pathway-specific basophil anergy induced by peanut oral immunotherapy in peanut-allergic children. *Clin Exp Allergy*. 2012;42(8):1197-1205.
185. Gorelik M, Narisety SD, Guerrerio AL, et al. Suppression of the immunologic response to peanut during immunotherapy is often transient. *J Allergy Clin Immunol*. 2015;135(5):1283-1292.
186. Patil SU, Steinbrecher J, Calatroni A, et al. Early decrease in basophil sensitivity to Ara h 2 precedes sustained unresponsiveness after peanut oral immunotherapy. *J Allergy Clin Immunol*. 2019;144(5):1310-1319.e1314.
187. MacGlashan DW Jr, Saini SS. Omalizumab increases the intrinsic sensitivity of human basophils to IgE-mediated stimulation. *J Allergy Clin Immunol*. 2013;132(4):906-911. e901-904.
188. Savage JH, Courneya JP, Sterba PM, MacGlashan DW, Saini SS, Wood RA. Kinetics of mast cell, basophil, and oral food challenge responses in omalizumab-treated adults with peanut allergy. *J Allergy Clin Immunol*. 2012;130(5):1123-1129.e1122.
189. MacGlashan DW Jr, Savage JH, Wood RA, Saini SS. Suppression of the basophil response to allergen during treatment with omalizumab is dependent on 2 competing factors. *J Allergy Clin Immunol*. 2012;130(5):1130-1135.e1135.
190. van der Kleij HPM, Warmenhoven HJM, van Ree R, et al. Chemically modified peanut extract shows increased safety while maintaining immunogenicity. *Allergy*. 2019;74(5):986-995.

191. Hemmings O, Du Toit G, Radulovic S, Lack G, Santos AF. Ara h 2 is the dominant peanut allergen despite similarities with Ara h 6. *J Allergy Clin Immunol*. 2020;146(3):621-630.e625.
192. Sabato V, van Hengel AJ, De Knop KJ, et al. Basophil activation reveals divergent patient-specific responses to thermally processed peanuts. *J Investig Allergol Clin Immunol*. 2011;21(7):527-531.
193. Bencharitwong R, van der Kleij HP, Koppelman SJ, Nowak-Węgrzyn A. Effect of chemical modifications on allergenic potency of peanut proteins. *Allergy Asthma Proc*. 2015;36(3):185-191.
194. Koppelman SJWM, Ertmann M, et al. Relevance of Ara h1, Ara h2 and Ara h3 in peanut-allergic patients, as determined by immunoglobulin E Western blotting, basophil-histamine release and intracutaneous testing: Ara h2 is the most important peanut allergen. *Clin Exp Allergy*. 2004 Apr;34(4):583-590. doi:10.1111/j.1365-2222.2004.1923.x
195. Klueber J, Schrama D, Rodrigues P, Dickel H, Kuehn A. Fish allergy management: from component-resolved diagnosis to unmet diagnostic needs. *Curr Treat Options Allergy*. 2019;6:322-337.
196. Sabato VHA, De Knop KJ, et al. Human basophils: a unique biological instrument to detect the allergenicity of food. *J Investig Allergol Clin Immunol*. 2011;21(3):179-184.
197. Sato S, Tachimoto H, Shukuya A, et al. Basophil activation marker CD203c is useful in the diagnosis of hen's egg and cow's milk allergies in children. *Int Arch Allergy Immunol*. 2010;152(Suppl 1):54-61.
198. Ruinemans-Koerts J, Schmidt-Hieltjes Y, Jansen A, Savelkoul HFJ, Plaisier A, van Setten P. The Basophil Activation Test reduces the need for a food challenge test in children suspected of IgE-mediated cow's milk allergy. *Clin Exp Allergy*. 2019;49(3):350-356.
199. Tokuda R, Nagao M, Hiraguchi Y, et al. Antigen-induced expression of CD203c on basophils predicts IgE-mediated wheat allergy. *Allergol Int*. 2009;58(2):193-199.
200. Chinuki Y, Kaneko S, Dekio I, et al. CD203c expression-based basophil activation test for diagnosis of wheat-dependent exercise-induced anaphylaxis. *J Allergy Clin Immunol*. 2012;129:1404-1406.
201. Gabler AM, Gebhard J, Eberlein B, Biedermann T, Scherf KA, Brockow K. The basophil activation test differentiates between patients with wheat-dependent exercise-induced anaphylaxis and control subjects using gluten and isolated gluten protein types. *Clin Transl Allergy*. 2021;11(6):e12050.
202. Glaumann S, Nilsson C, Johansson SG, et al. Evaluation of basophil allergen threshold sensitivity (CD-sens) to peanut and Ara h 8 in children IgE-sensitized to Ara h 8. *Clin Mol Allergy*. 2015;13(1):5.
203. Mayorga C, Gomez F, Aranda A, et al. Basophil response to peanut allergens in Mediterranean peanut-allergic patients. *Allergy*. 2014;69(7):964-968.
204. Hayen SM, Ehlers AM, den Hartog Jager CF, et al. 2S protein Ara h 7.0201 has unique epitopes compared to other Ara h 7 isoforms and is comparable to 2S proteins Ara h 2 and 6 in basophil degranulation capacity. *Clin Exp Allergy*. 2018;48(7):890-897.
205. Gamboa PM, Cáceres O, Antepara I, et al. Two different profiles of peach allergy in the north of Spain. *Allergy*. 2007;62(4):408-414.
206. Erdmann SM, Sachs B, Schmidt A, et al. *In vitro* analysis of birch-pollen-associated food allergy by use of recombinant allergens in the basophil activation test. *Int Arch Allergy Immunol*. 2005;136(3):230-238.
207. Wai CYY, Leung NYH, Leung ASY, et al. Cell-Based Functional IgE Assays Are Superior to Conventional Allergy Tests for Shrimp Allergy Diagnosis. *J Allergy Clin Immunol Pract*. 2021;9(1):236-244.e239.
208. Kalic T, Morel-Codreanu F, Radauer C, et al. Patients Allergic to Fish Tolerate Ray Based on the Low Allergenicity of Its Parvalbumin. *J Allergy Clin Immunol Pract*. 2019;7(2):500-508.e511.
209. Blank S, Grosch J, Ollert M, Bilò MB. Precision Medicine in Hymenoptera Venom Allergy: Diagnostics, Biomarkers, and Therapy of Different Endotypes and Phenotypes. *Front Immunol*. 2020;11:579409.
210. Seismann H, Blank S, Cifuentes L, et al. Recombinant phospholipase A1 (Ves v 1) from yellow jacket venom for improved diagnosis of hymenoptera venom hypersensitivity. *Clin Mol Allergy*. 2010;8:7.
211. Blank S, Seismann H, Bockisch B, et al. Identification, recombinant expression, and characterization of the 100 kDa high molecular weight Hymenoptera venom allergens Api m 5 and Ves v 3. *J Immunol*. 2010;184(9):5403-5413.
212. Balzer L, Pennino D, Blank S, et al. Basophil activation test using recombinant allergens: highly specific diagnostic method complementing routine tests in wasp venom allergy. *PLoS One*. 2014;9(10):e108619. Published 2014 Oct 17. doi:10.1371/journal.pone.0108619
213. Schiener M, Eberlein B, Moreno-Aguilar C, et al. Application of recombinant antigen 5 allergens from seven allergy-relevant Hymenoptera species in diagnostics. *Allergy*. 2017;72(1):98-108.
214. Schiener M, Hilger C, Eberlein B, et al. The high molecular weight dipeptidyl peptidase IV Pol d 3 is a major allergen of *Polistes dominula* venom. *Sci Rep*. 2018;8(1):1318.
215. Grosch J, Eberlein B, Waldherr S, et al. Characterization of New Allergens from the Venom of the European Paper Wasp *Polistes dominula*. *Toxins (Basel)*. 2021;13(8):559. Published 2021 Aug 10. doi:10.3390/toxins13080559
216. Russkamp D, Van Vaerenbergh M, Etzold S, et al. Characterization of the honeybee venom proteins C1q-like protein and PVF1 and their allergenic potential. *Toxicon*. 2018;150:198-206.
217. Waldherr S, Grosch J, Hilger C, et al. Assessment of homologous phospholipases (*Polistes* and bee venom PLA2) and hyaluronidases (Pol d 2, Api m2, Ves v 2b) in patients with bee and yellow jacket venom allergy by basophil activation testing. *Poster EuroBAT*. 2020; digital.
218. Koren A, Lunder M, Molek P, et al. Fluorescent labeling of major honeybee allergens Api m 1 and Api m 2 with quantum dots and the development of a multiplex basophil activation test. *Allergy*. 2020;75(7):1753-1756.
219. Zahirović A, Koren A, Kopač P, Štrukelj B, Korošec P, Lunder M. Identification of bee venom Api m 1 IgE epitopes and characterization of corresponding mimotopes. *J Allergy Clin Immunol*. 2019;143(2):791-794.e795.
220. Hauswirth AW, Natter S, Ghannadan M, et al. Recombinant allergens promote expression of CD203c on basophils in sensitized individuals. *J Allergy Clin Immunol*. 2002;110(1):102-109.
221. Lee JY, Yang M, Jeong KY, et al. Characterization of a Major Allergen from Mongolian Oak, *Quercus mongolica*, a Dominant Species of Oak in Korea. *Int Arch Allergy Immunol*. 2017;174(2):77-85.
222. Grilo JR, Kitzmüller C, Aglas L, et al. IgE-cross-blocking antibodies to Fagales following sublingual immunotherapy with recombinant Bet v 1. *Allergy*. 2021;76(8):2555-2564.
223. Sánchez Acosta G, Kinaciyar T, Kitzmüller C, Möbs C, Pfütznner W, Bohle B. IgE-blocking antibodies following SLIT with recombinant Mal d 1 accord with improved apple allergy. *J Allergy Clin Immunol*. 2020;146(4):894-900.e892.
224. Schober W, Belloni B, Lubitz S, et al. Organic extracts of urban aerosol (< or =PM2.5) enhance rBet v 1-induced upregulation of CD63 in basophils from birch pollen-allergic individuals. *Toxicol Sci*. 2006;90(2):377-384.
225. Lubitz S, Schober W, Pusch G, et al. Polycyclic aromatic hydrocarbons from diesel emissions exert proallergic effects in birch pollen allergic individuals through enhanced mediator release from basophils. *Environ Toxicol*. 2010;25(2):188-197.
226. Marth K, Breyer I, Focke-Tejkl M, et al. A nonallergenic birch pollen allergy vaccine consisting of hepatitis PreS-fused Bet v 1 peptides focuses blocking IgG toward IgE epitopes and shifts immune responses to a tolerogenic and Th1 phenotype. *J Immunol*. 2013;190(7):3068-3078.

227. Campana R, Vrtala S, Maderegger B, et al. Hypoallergenic derivatives of the major birch pollen allergen Bet v 1 obtained by rational sequence reassembly. *J Allergy Clin Immunol*. 2010;126(5):1024-1031. doi:10.1016/j.jaci.2010.09.016.
228. Mikkelsen S, Bibby BM, Dolberg MK, Dahl R, Hoffmann HJ. Basophil sensitivity through CD63 or CD203c is a functional measure for specific immunotherapy. *Clin Mol Allergy*. 2010;8(1):2.
229. Lalek N, Kosnik M, Silar M, Korosec P. Immunoglobulin G-dependent changes in basophil allergen threshold sensitivity during birch pollen immunotherapy. *Clin Exp Allergy*. 2010;40(8):1186-1193.
230. Sénéchal H, Keykhosravi S, Couderc R, et al. Pollen/Fruit Syndrome: Clinical Relevance of the Cypress Pollen Allergenic Gibberellin-Regulated Protein. *Allergy Asthma Immunol Res*. 2019;11(1):143-151.
231. Klingebiel C, Chantran Y, Arif-Lusson R, et al. Pru p 7 sensitization is a predominant cause of severe, cypress pollen-associated peach allergy. *Clin Exp Allergy*. 2019;49(4):526-536.
232. Campana RVS, Maderegger B, et al. Altered IgE epitope presentation: A model for hypoallergenic activity revealed for Bet v 1 trimer. *Mol Immunol*. 2011;48(4):431-441. doi:10.1016/j.molimm.2010.09.016
233. Linhart B, Focke-Tejkl M, Weber M, et al. Molecular evolution of hypoallergenic hybrid proteins for vaccination against grass pollen allergy. *J Immunol*. 2015;194(8):4008-4018.
234. Sonneck KBC, Rebuzzi L, et al. Recombinant allergens promote expression of aminopeptidase-n (CD13) on basophils in allergic patients. *Int J Immunopathol Pharmacol*. 2008;21(1):11-21. doi:10.1177/039463200802100103
235. Smiljkovic DKR, Lupinek C, et al. Microarray-Based Detection of Allergen-Reactive IgE in Patients with Mastocytosis. *J Allergy Clin Immunol Pract*. 2020;8(8):2761-2768.e16. doi:10.1016/j.jaip.2020.04.030
236. Focke-Tejkl M, Weber M, Niespodziana K, et al. Development and characterization of a recombinant, hypoallergenic, peptide-based vaccine for grass pollen allergy. *J Allergy Clin Immunol*. 2015;135(5):1207-1207.e1201-1211.
237. Focke-Tejkl MCR, Reininger R, et al. Dissection of the IgE and T-cell recognition of the major group 5 grass pollen allergen Phl p 5. *J Allergy Clin Immunol*. 2014;133(3):836-45.e11. doi:10.1016/j.jaci.2013.08.038
238. Gadermaier EFS, Blatt K, et al. Possible therapeutic potential of a recombinant group 2 grass pollen allergen-specific antibody fragment. *Allergy*. 2014;69(2):261-264. doi:10.1111/all.12315
239. Najafi N, Hofer G, Gattlinger P, et al. Fusion proteins consisting of Bet v 1 and Phl p 5 form IgE-reactive aggregates with reduced allergenic activity. *Sci Rep*. 2019;9(1):4006. Published 2019 Mar 8. doi:10.1038/s41598-019-39798-8
240. Dorofeeva Y, Colombo P, Blanca M, et al. Expression and characterization of recombinant Par j 1 and Par j 2 resembling the allergenic epitopes of *Parietaria judaica* pollen. *Sci Rep*. 2019;9(1):15043.
241. Zieglmayer PF-TM, Schmutz R, et al. Mechanisms, safety and efficacy of a B cell epitope-based vaccine for immunotherapy of grass pollen allergy. *EBioMedicine*. 2016;11:43-57. doi:10.1016/j.ebiom.2016.08.022
242. Bonura A, Gulino L, Trapani A, et al. Isolation, expression and immunological characterization of a calcium-binding protein from *Parietaria pollen*. *Mol Immunol*. 2008;45(9):2465-2473.
243. Weghofer M, Grote M, Resch Y, et al. Identification of Der p 23, a peritrophin-like protein, as a new major *Dermatophagoides pteronyssinus* allergen associated with the peritrophic matrix of mite fecal pellets. *J Immunol*. 2013;190(7):3059-3067.
244. Resch Y, Blatt K, Malkus U, et al. Molecular, Structural and Immunological Characterization of Der p 18, a Chitinase-Like House Dust Mite Allergen. *PLoS One*. 2016;11(8):e0160641.
245. An S, Shen C, Liu X, et al. Alpha-actinin is a new type of house dust mite allergen. *PLoS One*. 2013;8(12):e81377.
246. Chen KW, Fuchs G, Sonneck K, et al. Reduction of the *in vivo* allergenicity of Der p 2, the major house-dust mite allergen, by genetic engineering. *Mol Immunol*. 2008;45(9):2486-2498.
247. Chen KW, Focke-Tejkl M, Blatt K, et al. Carrier-bound nonallergenic Der p 2 peptides induce IgG antibodies blocking allergen-induced basophil activation in allergic patients. *Allergy*. 2012;67(5):609-621.
248. Banerjee S, Weber M, Blatt K, et al. Conversion of Der p 23, a new major house dust mite allergen, into a hypoallergenic vaccine. *J Immunol*. 2014;192(10):4867-4875.
249. Huang HJ, Curin M, Banerjee S, et al. A hypoallergenic peptide mix containing T cell epitopes of the clinically relevant house dust mite allergens. *Allergy*. 2019;74(12):2461-2478.
250. Wigginton SJ, Furtado PB, Armour KL, et al. An immunoglobulin E-reactive chimeric human immunoglobulin G1 anti-idiotypic inhibits basophil degranulation through cross-linking of FcεRI with FcγRIIb. *Clin Exp Allergy*. 2008;38(2):313-319.
251. Zidarn MRM, Krivec A, et al. Clinical and immunological differences between asymptomatic HDM-sensitized and HDM-allergic rhinitis patients. *Clin Exp Allergy*. 2019;49(6):808-818. doi:10.1111/cea.13361
252. Wei JFYH, Li D, Gao P, He S. Preparation and identification of Per a 5 as a novel American cockroach allergen. *Mediators Inflamm*. 2014;2014:591468. doi:10.1155/2014/591468
253. Yang H, Chen H, Jin M, Xie H, He S, Wei JF. Molecular cloning, expression, IgE binding activities and *in silico* epitope prediction of Per a 9 allergens of the American cockroach. *Int J Mol Med*. 2016;38(6):1795-1805.
254. Tong X, Guo M, Jin M, Chen H, Li Y, Wei JF. *In silico* epitope prediction, expression and functional analysis of Per a 10 allergen from the American cockroach. *Int J Mol Med*. 2016;38(6):1806-1814.
255. Reininger R, Swoboda I, Bohle B, et al. Characterization of recombinant cat albumin. *Clin Exp Allergy*. 2003;33(12):1695-1702.
256. Ocmant A, Peignois Y, Mulier S, Hanssens L, Michils A, Schandené L. Flow cytometry for basophil activation markers: the measurement of CD203c up-regulation is as reliable as CD63 expression in the diagnosis of cat allergy. *J Immunol Methods*. 2007;320(1-2):40-48.
257. Zhu DX, Li L, Xu ZQ, et al. Cat-NPC2, a Newly Identified Allergen, With High Cross-Reactivity to Can f 7. *Allergy Asthma Immunol Res*. 2021;13(1):122-140.
258. Niespodziana K, Focke-Tejkl M, Linhart B, et al. A hypoallergenic cat vaccine based on Fel d 1-derived peptides fused to hepatitis B PreS. *J Allergy Clin Immunol*. 2011;127(6):1562-1570.e1566.
259. Curin M, Weber M, Thalhamer T, et al. Hypoallergenic derivatives of Fel d 1 obtained by rational reassembly for allergy vaccination and tolerance induction. *Clin Exp Allergy*. 2014;44(6):882-894.
260. Wang YJ, Li L, Song WJ, et al. Canis familiaris allergen Can f 6: expression, purification and analysis of B-cell epitopes in Chinese dog allergic children. *Oncotarget*. 2017;8(53):90796-90807.
261. Wintersand A, Asplund K, Binnmyr J, et al. Allergens in dog extracts: Implication for diagnosis and treatment. *Allergy*. 2019;74(8):1472-1479.
262. Käck U, Asarnoj A, Binnmyr J, et al. Basophil activation testing, IgG, and IgG4 in the diagnosis of dog allergy in children with and without a dog at home. *Allergy*. 2020;75(5):1269-1272.
263. Klimek L, Hoffmann HJ, Renz H, et al. Diagnostic test allergens used for *in vivo* diagnosis of allergic diseases are at risk: a European Perspective. *Allergy*. 2015;70(10):1329-1331.
264. Cardona V, Demoly P, Dreborg S, et al. Current practice of allergy diagnosis and the potential impact of regulation in Europe. *Allergy*. 2018;73(2):323-327.
265. Hoffmann HJ, Knol EF, Ferrer M, et al. Pros and Cons of Clinical Basophil Testing (BAT). *Curr Allergy Asthma Rep*. 2016;16(8):56.
266. van Hoffen E, van der Kleij HP, den Hartog Jager CF, et al. Chemical modification of peanut conglutinin reduces IgE reactivity but not T cell reactivity in peanut-allergic patients. *Clin Exp Allergy*. 2014;44(12):1558-1566.

267. Glaumann S, Nopp A, Johansson SG, Rudengren M, Borres MP, Nilsson C. Basophil allergen threshold sensitivity, CD-sens, IgE-sensitization and DBPCFC in peanut-sensitized children. *Allergy*. 2012;67(2):242-247.
268. Glaumann S, Nopp A, Johansson SG, Borres MP, Nilsson C. Oral peanut challenge identifies an allergy but the peanut allergen threshold sensitivity is not reproducible. *PLoS One*. 2013;8(1):e53465.
269. Santos AF, James LK, Bahnson HT, et al. IgG4 inhibits peanut-induced basophil and mast cell activation in peanut-tolerant children sensitized to peanut major allergens. *J Allergy Clin Immunol*. 2015;135(5):1249-1256.
270. Zbären N, Brigger D, Bachmann D, et al. A novel functional mast cell assay for the detection of allergies. *J Allergy Clin Immunol*. 2022;149(3):1018-1030.e1011.
271. Agyemang A, Suprun M, Suárez-Fariñas M, et al. A novel approach to the basophil activation test for characterizing peanut allergic patients in the clinical setting. *Allergy*. 2021;76(7):2257-2259.
272. Franzese CB. AAOA allergy primer: history and physical examination. *Int Forum Allergy Rhinol*. 2014;4(Suppl 2):S28-S31.
273. Deschildre A, Lejeune S, Cap M, et al. Food allergy phenotypes: The key to personalized therapy. *Clin Exp Allergy*. 2017;47(9):1125-1137.
274. Simpson A, Lazić N, Belgrave DC, et al. Patterns of IgE responses to multiple allergen components and clinical symptoms at age 11 years. *J Allergy Clin Immunol*. 2015;136(5):1224-1231.
275. Bousquet J, Heinzerling L, Bachert C, et al. Practical guide to skin prick tests in allergy to aeroallergens. *Allergy*. 2012;67(1):18-24.
276. Rancé F, Juchet A, Brémont F, Dutau G. Correlations between skin prick tests using commercial extracts and fresh foods, specific IgE, and food challenges. *Allergy*. 1997;52(10):1031-1035.
277. Valenta R, Karaulov A, Niederberger V, et al. Allergen extracts for *in vivo* diagnosis and treatment of allergy: is there a future? *J Allergy Clin Immunol Pract*. 2018;6(6):1845-1855.e1842.
278. Lin J, Li M, Liu Y, et al. Expression, purification and characterization of Der f 27, a new allergen from dermatophagoides farinae. *Am J Transl Res*. 2015;7(7):1260-1270.
279. Martínez-Aranguren RM, Gamboa PM, García-Lirio E, Asturias J, Goikoetxea MJ, Sanz ML. *In vivo* and *in vitro* testing with rAni s 1 can facilitate diagnosis of Anisakis simplex allergy. *J Investig Allergol Clin Immunol*. 2014;24(6):431-438.
280. Barber D, de la Torre F, Lombardero M, et al. Component-resolved diagnosis of pollen allergy based on skin testing with profilin, polcalcain and lipid transfer protein pan-allergens. *Clin Exp Allergy*. 2009;39(11):1764-1773.
281. Douladiris N, Linhart B, Swoboda I, et al. *In vivo* allergenic activity of a hypoallergenic mutant of the major fish allergen Cyp c 1 evaluated by means of skin testing. *J Allergy Clin Immunol*. 2015;136(2):493-495.e498.
282. Douladiris N, Garib V, Focke-Tejkl M, Valenta R, Papadopoulos NG, Linhart B. Detection of genuine grass pollen sensitization in children by skin testing with a recombinant grass pollen hybrid. *Pediatr Allergy Immunol*. 2019;30(1):59-65.
283. Augé J, Vent J, Agache I, et al. EAACI Position paper on the standardization of nasal allergen challenges. *Allergy*. 2018;73(8):1597-1608.
284. Sindher S, Long AJ, Purington N, et al. Analysis of a Large Standardized Food Challenge Data Set to Determine Predictors of Positive Outcome Across Multiple Allergens. *Front Immunol*. 2018;9:2689.
285. Rondon C, Campo P, Eguiluz-Gracia I, et al. Local allergic rhinitis is an independent rhinitis phenotype: The results of a 10-year follow-up study. *Allergy*. 2018;73(2):470-478.
286. Niederberger V, Stübner P, Spitzauer S, et al. Skin test results but not serology reflect immediate type respiratory sensitivity: a study performed with recombinant allergen molecules. *J Invest Dermatol*. 2001;117(4):848-851.
287. Campo P, Villalba M, Barrionuevo E, et al. Immunologic responses to the major allergen of *Olea europaea* in local and systemic allergic rhinitis subjects. *Clin Exp Allergy*. 2015;45(11):1703-1712.
288. Ruoppi P, Virtanen T, Zeiler T, et al. *In vitro* and *in vivo* responses to the recombinant bovine dander allergen Bos d 2 and its fragments. *Clin Exp Allergy*. 2001;31(6):915-919.
289. Gherasim A, Fauquert JL, Domis N, Siomboing X, de Blay F. Birch allergen challenges in allergic conjunctivitis using standard conjunctival allergen challenge and environmental exposure chamber. *Clin Transl Allergy*. 2021;11(6):e12053.
290. Pfaar O, Calderon MA, Andrews CP, et al. Allergen exposure chambers: harmonizing current concepts and projecting the needs for the future - an EAACI Position Paper. *Allergy*. 2017;72(7):1035-1042.
291. Niederberger V, Eckl-Dorna J, Pauli G. Recombinant allergen-based provocation testing. *Methods*. 2014;66(1):96-105.
292. Taylor G, Walker J. Charles Harrison Blackley, 1820-1900. *Clin Allergy*. 1973;3(2):103-108.
293. Diamant Z, Gauvreau GM, Cockcroft DW, et al. Inhaled allergen bronchoprovocation tests. *J Allergy Clin Immunol*. 2013;132(5):1045-1055.e1046.
294. Preisser AM, Kraft AM, Harth V. Severe bronchial reaction to provocation with fish and crustaceans. *Allergol Select*. 2020;4:118-123.
295. Pajno GB, Fernandez-Rivas M, Arasi S, et al. EAACI Guidelines on allergen immunotherapy: IgE-mediated food allergy. *Allergy*. 2018;73(4):799-815.
296. Santos AF, Du Toit G, O'Rourke C, et al. Biomarkers of severity and threshold of allergic reactions during oral peanut challenges. *J Allergy Clin Immunol*. 2020;146(2):344-355.
297. Jurd RD. Hypersensitivity in fishes: a review. *J Fish Biol*. 1987;31:1-7.
298. Sung SC, Cheng CH, Chou CM, et al. Expression and characterization of a constitutively active STAT6 from Tetraodon. *Fish Shellfish Immunol*. 2010;28(5-6):819-828.
299. Hirasawa R, Shimizu R, Takahashi S, et al. Essential and instructive roles of GATA factors in eosinophil development. *J Exp Med*. 2002;195(11):1379-1386.
300. Jackson JA, Friberg IM, Bolch L, et al. Immunomodulatory parasites and toll-like receptor-mediated tumour necrosis factor alpha responsiveness in wild mammals. *BMC Biol*. 2009;7:16.
301. Sattler S, Smits HH, Xu D, Huang FP. The evolutionary role of the IL-33/ST2 system in host immune defence. *Arch Immunol Ther Exp (Warsz)*. 2013;61(2):107-117.
302. Rivers-Auty J, Daniels MJD, Colliver I, Robertson DL, Brough D. Redefining the ancestral origins of the interleukin-1 superfamily. *Nat Commun*. 2018;9(1):1156.
303. Pritchard DI, Falcone FH, Mitchell PD. The evolution of IgE-mediated type I hypersensitivity and its immunological value. *Allergy*. 2021;76(4):1024-1040.
304. Fitzsimmons CM, Falcone FH, Dunne DW. Helminth Allergens, Parasite-Specific IgE, and Its Protective Role in Human Immunity. *Front Immunol*. 2014;5:61.
305. Berzofsky JA. Intrinsic and extrinsic factors in protein antigenic structure. *Science*. 1985;229(4717):932-940.
306. Melioli G, Marcomini L, Agazzi A, et al. The IgE repertoire in children and adolescents resolved at component level: a cross-sectional study. *Pediatr Allergy Immunol*. 2012;23(5):433-440.
307. Schwarz A, Panetta V, Cappella A, et al. IgG and IgG(4) to 91 allergenic molecules in early childhood by route of exposure and current and future IgE sensitization: Results from the Multicentre Allergy Study birth cohort. *J Allergy Clin Immunol*. 2016;138(5):1426-1433.e1412.
308. Huang X, Tsilochristou O, Perna S, et al. Evolution of the IgE and IgG repertoire to a comprehensive array of allergen molecules in the first decade of life. *Allergy*. 2018;73(2):421-430.

309. Hatzler L, Panetta V, Lau S, et al. Molecular spreading and predictive value of preclinical IgE response to Phleum pratense in children with hay fever. *J Allergy Clin Immunol*. 2012;130(4):894-901. e895.
310. Posa D, Hofmaier S, Arasi S, Matricardi PM. Natural Evolution of IgE Responses to Mite Allergens and Relationship to Progression of Allergic Disease: a Review. *Curr Allergy Asthma Rep*. 2017;17(5):28.
311. Custovic A, Sonntag HJ, Buchan IE, Belgrave D, Simpson A, Prosperi MCF. Evolution pathways of IgE responses to grass and mite allergens throughout childhood. *J Allergy Clin Immunol*. 2015;136(6):1645-1652.
312. Asarnoj A, Hamsten C, Wadén K, et al. Sensitization to cat and dog allergen molecules in childhood and prediction of symptoms of cat and dog allergy in adolescence: A BAMSE/MeDALL study. *J Allergy Clin Immunol*. 2016;137(3):813-821.e817.
313. Asarnoj A, Hamsten C, Lupinek C, et al. Prediction of peanut allergy in adolescence by early childhood storage protein-specific IgE signatures: The BAMSE population-based birth cohort. *J Allergy Clin Immunol*. 2017;140(2):587-590.e587.
314. Mistry J, Chuguransky S, Williams L, et al. Pfam: The protein families database in 2021. *Nucleic Acids Res*. 2021;49(D1):D412-d419.
315. Platts-Mills TA, Woodfolk JA. Allergens and their role in the allergic immune response. *Immunol Rev*. 2011;242(1):51-68.
316. Wills-Karp M. Allergen-specific pattern recognition receptor pathways. *Curr Opin Immunol*. 2010;22(6):777-782.
317. Trompette A, Divanovic S, Visintin A, et al. Allergenicity resulting from functional mimicry of a Toll-like receptor complex protein. *Nature*. 2009;457(7229):585-588.
318. Herre J, Grönlund H, Brooks H, et al. Allergens as immunomodulatory proteins: the cat dander protein Fel d 1 enhances TLR activation by lipid ligands. *J Immunol*. 2013;191(4):1529-1535.
319. Shreffler WG, Castro RR, Kucuk ZY, et al. The major glycoprotein allergen from *Arachis hypogaea*, Ara h 1, is a ligand of dendritic cell-specific ICAM-grabbing nonintegrin and acts as a Th2 adjuvant *in vitro*. *J Immunol*. 2006;177(6):3677-3685.
320. Sun G, Stacey MA, Schmidt M, Mori L, Mattoli S. Interaction of mite allergens Der p3 and Der p9 with protease-activated receptor-2 expressed by lung epithelial cells. *J Immunol*. 2001;167(2):1014-1021.
321. Shewry PR, Halford NG, Belton PS, Tatham AS. The structure and properties of gluten: an elastic protein from wheat grain. *Philos Trans R Soc Lond B Biol Sci*. 2002;357(1418):133-142.
322. Tatham AS, Shewry PR. Allergens to wheat and related cereals. *Clin Exp Allergy*. 2008;38(11):1712-1726.
323. Oda Y, Matsunaga T, Fukuyama K, Miyazaki T, Morimoto T. Tertiary and quaternary structures of O.19 alpha-amylase inhibitor from wheat kernel determined by X-ray analysis at 2.06 Å resolution. *Biochemistry*. 1997;36(44):13503-13511.
324. Salcedo G, Quirce S, Diaz-Perales A. Wheat allergens associated with Baker's asthma. *J Investig Allergol Clin Immunol*. 2011;21(2):81-92. quiz 94.
325. Moreno FJ, Clemente A. 2S Albumin Storage Proteins: What Makes them Food Allergens? *Open Biochem J*. 2008;2:16-28.
326. Egger M, Hauser M, Mari A, Ferreira F, Gadermaier G. The role of lipid transfer proteins in allergic diseases. *Curr Allergy Asthma Rep*. 2010;10(5):326-335.
327. Lewit-Bentley A, Réty S. EF-hand calcium-binding proteins. *Curr Opin Struct Biol*. 2000;10(6):637-643.
328. Magler I, Nüss D, Hauser M, Ferreira F, Brandstetter H. Molecular metamorphosis in polyclonal allergens by EF-hand rearrangements and domain swapping. *FEBS J*. 2010;277(12):2598-2610.
329. Kuehn A, Swoboda I, Arumugam K, Hilger C, Hentges F. Fish allergens at a glance: variable allergenicity of parvalbumins, the major fish allergens. *Front Immunol*. 2014;5:179.
330. Hermann A, Cox JA. Sarcoplasmic calcium-binding protein. *Comp Biochem Physiol B Biochem Mol Biol*. 1995;111(3):337-345.
331. Gao Y, Gillen CM, Wheatly MG. Molecular characterization of the sarcoplasmic calcium-binding protein (SCP) from crayfish *Procambarus clarkii*. *Comp Biochem Physiol B Biochem Mol Biol*. 2006;144(4):478-487.
332. Haiech J, Moreau M, Leclerc C, Kilhoffer MC. Facts and conjectures on calmodulin and its cousin proteins, parvalbumin and troponin C. *Biochim Biophys Acta Mol Cell Res*. 2019;1866(7):1046-1053.
333. Preller M, Manstein DJ. Myosin structure, allostery, and mechanochemistry. *Structure*. 2013;21(11):1911-1922.
334. Reese G, Ayuso R, Lehrer SB. Tropomyosin: an invertebrate pan-allergen. *Int Arch Allergy Immunol*. 1999;119(4):247-258.
335. Lopata AL, O'Hehir RE, Lehrer SB. Shellfish allergy. *Clin Exp Allergy*. 2010;40(6):850-858.
336. Radauer C, Willeroider M, Fuchs H, et al. Cross-reactive and species-specific immunoglobulin E epitopes of plant profilins: an experimental and structure-based analysis. *Clin Exp Allergy*. 2006;36(7):920-929.
337. Hauser M, Roulias A, Ferreira F, Egger M. Panallergens and their impact on the allergic patient. *Allergy Asthma Clin Immunol*. 2010;6(1):1.
338. Asero R, Ariano R, Aruanno A, et al. Systemic allergic reactions induced by labile plant-food allergens: Seeking potential cofactors. A multicenter study. *Allergy*. 2021;76(5):1473-1479.
339. Rosace D, Gomez-Casado C, Fernandez P, et al. Profilin-mediated food-induced allergic reactions are associated with oral epithelial remodeling. *J Allergy Clin Immunol*. 2019;143(2):681-690. e681.
340. Radauer C, Lackner P, Breiteneder H. The Bet v 1 fold: an ancient, versatile scaffold for binding of large, hydrophobic ligands. *BMC Evol Biol*. 2008;8:286.
341. Willison LN, Sathe SK, Roux KH. Production and analysis of recombinant tree nut allergens. *Methods*. 2014;66(1):34-43.
342. D'Avino R, Bernardi ML, Wallner M, et al. Kiwifruit Act d 11 is the first member of the ripening-related protein family identified as an allergen. *Allergy*. 2011;66(7):870-877.
343. Guhsl EE, Hofstetter G, Hemmer W, et al. Vig r 6, the cytokinin-specific binding protein from mung bean (*Vigna radiata*) sprouts, cross-reacts with Bet v 1-related allergens and binds IgE from birch pollen allergic patients' sera. *Mol Nutr Food Res*. 2014;58(3):625-634.
344. Chiu HJ, Bakolitsa C, Skerra A, et al. Structure of the first representative of Pfam family PF09410 (DUF2006) reveals a structural signature of the calycin superfamily that suggests a role in lipid metabolism. *Acta Crystallogr Sect F Struct Biol Cryst Commun*. 2010;66(Pt 10):1153-1159.
345. Hilger C, Kuehn A, Hentges F. Animal lipocalin allergens. *Curr Allergy Asthma Rep*. 2012;12(5):438-447.
346. Hernández-Vargas MJ, Santibáñez-López CE, Corzo G. An Insight into the Triabin Protein Family of American Hematophagous Reduviids: Functional, Structural and Phylogenetic Analysis. *Toxins (Basel)*. 2016;8(2):44.
347. Castillo RM, Mizuguchi K, Dhanaraj V, Albert A, Blundell TL, Murzin AG. A six-stranded double-psi beta barrel is shared by several protein superfamilies. *Structure*. 1999;7(2):227-236.
348. Sampedro J, Cosgrove DJ. The expansin superfamily. *Genome Biol*. 2005;6(12):242.
349. Cosgrove DJ, Bedinger P, Durachko DM. Group I allergens of grass pollen as cell wall-loosening agents. *Proc Natl Acad Sci U S A*. 1997;94(12):6559-6564.
350. Tuppo L, Giangrieco I, Palazzo P, et al. Kiwellin, a modular protein from green and gold kiwi fruits: evidence of *in vivo* and *in vitro* processing and IgE binding. *J Agric Food Chem*. 2008;56(10):3812-3817.

351. Han X, Altegoer F, Steinchen W, et al. A kiwellin disarms the metabolic activity of a secreted fungal virulence factor. *Nature*. 2019;565(7741):650-653.
352. Berthelot K, Peruch F, Lecomte S. Highlights on Hevea brasiliensis (pro)hevein proteins. *Biochimie*. 2016;127:258-270.
353. Gibbs GM, Roelants K, O'Bryan MK. The CAP superfamily: cysteine-rich secretory proteins, antigen 5, and pathogenesis-related 1 proteins—roles in reproduction, cancer, and immune defense. *Endocr Rev*. 2008;29(7):865-897.
354. Abraham A, Chandler DE. Tracing the Evolutionary History of the CAP Superfamily of Proteins Using Amino Acid Sequence Homology and Conservation of Splice Sites. *J Mol Evol*. 2017;85(3-4):137-157.
355. Czerwinski EW, Midoro-Horiuti T, White MA, Brooks EG, Goldblum RM. Crystal structure of Jun a 1, the major cedar pollen allergen from *Juniperus ashei*, reveals a parallel beta-helical core. *J Biol Chem*. 2005;280(5):3740-3746.
356. Ghosh N, Sircar G, Asam C, et al. Purification and biochemical characterization of Hel a 6, a cross-reactive pectate lyase allergen from Sunflower (*Helianthus annuus* L.) pollen. *Sci Rep*. 2020;10(1):20177.
357. Pichler U, Hauser M, Wolf M, et al. Pectate lyase pollen allergens: sensitization profiles and cross-reactivity pattern. *PLoS One*. 2015;10(5):e0120038.
358. Stemeseder T, Freier R, Wildner S, et al. Crystal structure of Pla l 1 reveals both structural similarity and allergenic divergence within the Ole e 1-like protein family. *J Allergy Clin Immunol*. 2017;140(1):277-280.
359. Robledo Retana T, Bradley-Clarke J, Croll T, et al. Lig v 1 structure and the inflammatory response to the Ole e 1 protein family. *Allergy*. 2020;75(9):2395-2398.
360. Mills EN, Jenkins JA, Alcocer MJ, Shewry PR. Structural, biological, and evolutionary relationships of plant food allergens sensitizing via the gastrointestinal tract. *Crit Rev Food Sci Nutr*. 2004;44(5):379-407.
361. Rawlings ND, Bateman A. How to use the MEROPS database and website to help understand peptidase specificity. *Protein Sci*. 2021;30(1):83-92.
362. Zhai Y, Cui Y, Song M, Vainstein A, Chen S, Ma H. Papain-Like Cysteine Protease Gene Family in Fig (*Ficus carica* L.): Genome-Wide Analysis and Expression Patterns. *Front. Plant Sci*. 2021;12:681801.
363. Radauer C, Breiteneder H. Allergen databases—A critical evaluation. *Allergy*. 2019;74(11):2057-2060.
364. Noon L. Prophylactic inoculation against hay fever. *Lancet*. 1911;1572-1573.
365. Jongejan L, van Ree R, Poulsen LK. Hypoallergenic molecules for subcutaneous immunotherapy. *Expert Rev Clin Immunol*. 2016;12(1):5-7.
366. Nielsen L, Johnsen CR, Mosbech H, Poulsen LK, Malling HJ. Antihistamine premedication in specific cluster immunotherapy: a double-blind, placebo-controlled study. *J Allergy Clin Immunol*. 1996;97(6):1207-1213.
367. Chaker AM, Shamji MH, Dumitru FA, et al. Short-term subcutaneous grass pollen immunotherapy under the umbrella of anti-IL-4: A randomized controlled trial. *J Allergy Clin Immunol*. 2016;137(2):452-461.e459.
368. Dantzer JA, Wood RA. Update on omalizumab in allergen immunotherapy. *Curr Opin Allergy Clin Immunol*. 2021;21(6):559-568.
369. Chapman MD, Ferreira F, Villalba M, et al. The European Union CREATE project: a model for international standardization of allergy diagnostics and vaccines. *J Allergy Clin Immunol*. 2008;122(5):882-889.e882.
370. Neske F, Schörner C, Buchheit KH, et al. BSP090—the follow-up to CREATE. *Arb Paul Ehrlich Inst Bundesinstitut Impfstoffe Biomed Arzneimittel Langen Hess*. 2009;96:12-19. discussion 19-20.
371. Himly M, Nandy A, Kahlert H, et al. Standardization of allergen products: 2. Detailed characterization of GMP-produced recombinant Phl p 5.0109 as European Pharmacopoeia reference standard. *Allergy*. 2016;71(4):495-504.
372. Kaul S, Zimmer J, Dehus O, et al. Standardization of allergen products: 3. Validation of candidate European Pharmacopoeia standard methods for quantification of major birch allergen Bet v 1. *Allergy*. 2016;71(10):1414-1424.
373. Zimmer J, Schmidt S, Kaul S, et al. Standardisation of allergen products: 4. Validation of a candidate European Pharmacopoeia standard method for quantification of major grass pollen allergen Phl p 5. *Allergy*. 2022;77(2):633-642.
374. Bonertz A, Roberts G, Slater JE, et al. Allergen manufacturing and quality aspects for allergen immunotherapy in Europe and the United States: An analysis from the EAACI AIT Guidelines Project. *Allergy*. 2018;73(4):816-826.
375. Englert L, Mahler V, Bonertz A. Regulatory Requirements for the Quality of Allergen Products for Allergen Immunotherapy of Food Allergy. *Curr Allergy Asthma Rep*. 2021;21(5):32.
376. Oppenheimer JJ, Nelson HS, Bock SA, Christensen F, Leung DY. Treatment of peanut allergy with rush immunotherapy. *J Allergy Clin Immunol*. 1992;90(2):256-262.
377. Burks AW, Jones SM, Wood RA, et al. Oral immunotherapy for treatment of egg allergy in children. *N Engl J Med*. 2012;367(3):233-243.
378. Caminiti L, Pajno GB, Crisafulli G, et al. Oral Immunotherapy for Egg Allergy: A Double-Blind Placebo-Controlled Study, with Postdesensitization Follow-Up. *J Allergy Clin Immunol Pract*. 2015;3(4):532-539.
379. Chinthrajah RS, Purington N, Andorf S, et al. Sustained outcomes in oral immunotherapy for peanut allergy (POISED study): a large, randomised, double-blind, placebo-controlled, phase 2 study. *Lancet*. 2019;394(10207):1437-1449.
380. O'B Hourihane J, Beyer K, Abbas A, et al. Efficacy and safety of oral immunotherapy with AR101 in European children with a peanut allergy (ARTEMIS): a multicentre, double-blind, randomised, placebo-controlled phase 3 trial. *Lancet Child Adolesc Health*. 2020;4(10):728-739.
381. Vickery BP, Vereda A, Casale TB, et al. AR101 Oral Immunotherapy for Peanut Allergy. *N Engl J Med*. 2018;379(21):1991-2001.
382. Andorf S, Purington N, Block WM, et al. Anti-IgE treatment with oral immunotherapy in multifood allergic participants: a double-blind, randomised, controlled trial. *Lancet Gastroenterol Hepatol*. 2018;3(2):85-94.
383. Wood RA, Kim JS, Lindblad R, et al. A randomized, double-blind, placebo-controlled study of omalizumab combined with oral immunotherapy for the treatment of cow's milk allergy. *J Allergy Clin Immunol*. 2016;137(4):1103-1110.
384. De Schryver S, Mazer B, Clarke AE, et al. Adverse Events in Oral Immunotherapy for the Desensitization of Cow's Milk Allergy in Children: A Randomized Controlled Trial. *J Allergy Clin Immunol Pract*. 2019;7(6):1912-1919.
385. Nowak-Węgrzyn A, Bloom KA, Sicherer SH, et al. Tolerance to extensively heated milk in children with cow's milk allergy. *J Allergy Clin Immunol*. 2008;122(2):342-347.
386. Lemon-Mulé H, Sampson HA, Sicherer SH, Shreffler WG, Noone S, Nowak-Węgrzyn A. Immunologic changes in children with egg allergy ingesting extensively heated egg. *J Allergy Clin Immunol*. 2008;122(5):977-983.
387. Turner PJ, Mehr S, Joshi P, et al. Safety of food challenges to extensively heated egg in egg-allergic children: a prospective cohort study. *Pediatr Allergy Immunol*. 2013;24(5):450-455.
388. Martos G, Lopez-Exposito I, Bencharitwong R, Berin MC, Nowak-Węgrzyn A. Mechanisms underlying differential food allergy response to heated egg. *J Allergy Clin Immunol*. 2011;127(4):990-997.

389. Shin M, Lee J, Ahn K, Lee SI, Han Y. The influence of the presence of wheat flour on the antigenic activities of egg white proteins. *Allergy Asthma Immunol Res*. 2013;5(1):42-47.
390. Kato Y, Oozawa E, Matsuda T. Decrease in antigenic and allergenic potentials of ovomucoid by heating in the presence of wheat flour: dependence on wheat variety and intermolecular disulfide bridges. *J Agric Food Chem*. 2001;49(8):3661-3665.
391. Kim EH, Bird JA, Kulis M, et al. Sublingual immunotherapy for peanut allergy: clinical and immunologic evidence of desensitization. *J Allergy Clin Immunol*. 2011;127(3):640-646.
392. Leonard SA, Sampson HA, Sicherer SH, et al. Dietary baked egg accelerates resolution of egg allergy in children. *J Allergy Clin Immunol*. 2012;130(2):473-480.
393. Kim EH, Perry TT, Wood RA, et al. Induction of sustained unresponsiveness after egg oral immunotherapy compared to baked egg therapy in children with egg allergy. *J Allergy Clin Immunol*. 2020;146(4):851-862.
394. Blanc F, Vissers YM, Adel-Patient K, et al. Boiling peanut Ara h 1 results in the formation of aggregates with reduced allergenicity. *Mol Nutr Food Res*. 2011;55(12):1887-1894.
395. Turner PJ, Mehr S, Sayers R, et al. Loss of allergenic proteins during boiling explains tolerance to boiled peanut in peanut allergy. *J Allergy Clin Immunol*. 2014;134(3):751-753.
396. Tao B, Morris S, Grzeskowiak L, Smith W, Forsyth K, Chataway T. Sequential hypoallergenic boiled peanut and roasted peanut oral immunotherapy. *Clin Exp Allergy*. 2017;47(11):1501-1504.
397. Hacini-Rachinel F, Vissers YM, Doucet-Ladev ze R, et al. Low-allergenic hydrolyzed egg induces oral tolerance in mice. *Int Arch Allergy Immunol*. 2014;164(1):64-73.
398. Giavi S, Vissers YM, Muraro A, et al. Oral immunotherapy with low allergenic hydrolyzed egg in egg allergic children. *Allergy*. 2016;71(11):1575-1584.
399. Wood RA, Sicherer SH, Burks AW, et al. A phase 1 study of heat/phenol-killed, *E. coli*-encapsulated, recombinant modified peanut proteins Ara h 1, Ara h 2, and Ara h 3 (EMP-123) for the treatment of peanut allergy. *Allergy*. 2013;68(6):803-808.
400. Enrique E, Pineda F, Malek T, et al. Sublingual immunotherapy for hazelnut food allergy: a randomized, double-blind, placebo-controlled study with a standardized hazelnut extract. *J Allergy Clin Immunol*. 2005;116(5):1073-1079.
401. Fern andez-Rivas M, Garrido Fern andez S, Nadal JA, et al. Randomized double-blind, placebo-controlled trial of sublingual immunotherapy with a Pru p 3 quantified peach extract. *Allergy*. 2009;64(6):876-883.
402. Kim EH, Yang L, Ye P, et al. Long-term sublingual immunotherapy for peanut allergy in children: Clinical and immunologic evidence of desensitization. *J Allergy Clin Immunol*. 2019;144(5):1320-1326.
403. Fleischer DM, Burks AW, Vickery BP, et al. Sublingual immunotherapy for peanut allergy: a randomized, double-blind, placebo-controlled multicenter trial. *J Allergy Clin Immunol*. 2013;131(1):119-127.
404. Burks AW, Wood RA, Jones SM, et al. Sublingual immunotherapy for peanut allergy: Long-term follow-up of a randomized multicenter trial. *J Allergy Clin Immunol*. 2015;135(5):1240-1248.
405. Keet CA, Frischmeyer-Guerrero PA, Thyagarajan A, et al. The safety and efficacy of sublingual and oral immunotherapy for milk allergy. *J Allergy Clin Immunol*. 2012;129(2):448-455.
406. Narisety SD, Frischmeyer-Guerrero PA, Keet CA, et al. A randomized, double-blind, placebo-controlled pilot study of sublingual versus oral immunotherapy for the treatment of peanut allergy. *J Allergy Clin Immunol*. 2015;135(5):1275-1282.
407. Jutel M, Jaeger L, Suck R, Meyer H, Fiebig H, Cromwell O. Allergen-specific immunotherapy with recombinant grass pollen allergens. *J Allergy Clin Immunol*. 2005;116(3):608-613.
408. Pauli G, Larsen TH, Rak S, et al. Efficacy of recombinant birch pollen vaccine for the treatment of birch-allergic rhinoconjunctivitis. *J Allergy Clin Immunol*. 2008;122(5):951-960.
409. Nandy A, H fner D, Klysner S. Recombinant allergens in specific immunotherapy. *Allergo J Int*. 2015;24:143-151.
410. Cooke RA, Menzel AE, Kessler WR, Myers PA. The antibody mechanisms of ragweed allergy; electrophoretic and chemical studies. I. The blocking antibody. *J Exp Med*. 1955;101(2):177-196.
411. Shamji MH, Kappen JH, Akdis M, et al. Biomarkers for monitoring clinical efficacy of allergen immunotherapy for allergic rhinoconjunctivitis and allergic asthma: an EAACI Position Paper. *Allergy*. 2017;72(8):1156-1173.
412. Scurlock AM, Burks AW, Sicherer SH, et al. Epicutaneous immunotherapy for treatment of peanut allergy: Follow-up from the Consortium for Food Allergy Research. *J Allergy Clin Immunol*. 2021;147(3):992-1003.
413. Flinterman AE, Knol EF, Lencer DA, et al. Peanut epitopes for IgE and IgG4 in peanut-sensitized children in relation to severity of peanut allergy. *J Allergy Clin Immunol*. 2008;121(3):737-743.
414. Vickery BP, Lin J, Kulis M, et al. Peanut oral immunotherapy modifies IgE and IgG4 responses to major peanut allergens. *J Allergy Clin Immunol*. 2013;131(1):128-134.
415. Shamji MH, Wilcock LK, Wachholz PA, et al. The IgE-facilitated allergen binding (FAB) assay: validation of a novel flow-cytometric based method for the detection of inhibitory antibody responses. *J Immunol Methods*. 2006;317(1-2):71-79.
416. Shamji MH, Lj rning C, Francis JN, et al. Functional rather than immunoreactive levels of IgG4 correlate closely with clinical response to grass pollen immunotherapy. *Allergy*. 2012;67(2):217-226.
417. Santos AF, James LK, Kwok M, et al. Peanut oral immunotherapy induces blocking antibodies but does not change the functional characteristics of peanut-specific IgE. *J Allergy Clin Immunol*. 2020;145(1):440-443.
418. Berin MC, Agashe C, Burks AW, et al. Allergen-specific T cells and clinical features of food allergy: Lessons from CoFAR immunotherapy cohorts. *J Allergy Clin Immunol*. 2022;149(4):1373-1382.
419. Varshney P, Jones SM, Scurlock AM, et al. A randomized controlled study of peanut oral immunotherapy: clinical desensitization and modulation of the allergic response. *J Allergy Clin Immunol*. 2011;127(3):654-660.
420. Wambre E, Bajzik V, DeLong JH, et al. A phenotypically and functionally distinct human T(H)2 cell subpopulation is associated with allergic disorders. *Sci Transl Med*. 2017;9(401).
421. Norman PS, Ohman JL Jr, Long AA, et al. Treatment of cat allergy with T-cell reactive peptides. *Am J Respir Crit Care Med*. 1996;154(6 Pt 1):1623-1628.
422. Maguire P, Nicodemus C, Robinson D, Aaronson D, Umetsu DT. The safety and efficacy of ALLERVAX CAT in cat allergic patients. *Clin Immunol*. 1999;93(3):222-231.
423. Patel D, Couroux P, Hickey P, et al. Fel d 1-derived peptide antigen desensitization shows a persistent treatment effect 1 year after the start of dosing: a randomized, placebo-controlled study. *J Allergy Clin Immunol*. 2013;131(1):103-109.
424. Niederberger V, Neubauer A, Gevaert P, et al. Safety and efficacy of immunotherapy with the recombinant B-cell epitope-based grass pollen vaccine BM32. *J Allergy Clin Immunol*. 2018;142(2):497-509.
425. Spertini F, DellaCorte G, Kettner A, et al. Efficacy of 2 months of allergen-specific immunotherapy with Bet v 1-derived contiguous overlapping peptides in patients with allergic rhinoconjunctivitis: Results of a phase IIb study. *J Allergy Clin Immunol*. 2016;138(1):162-168.
426. Kettner A, DellaCorte G, de Blay F, et al. Benefit of Bet v 1 contiguous overlapping peptide immunotherapy persists during first follow-up season. *J Allergy Clin Immunol*. 2018;142(2):678-680.

427. Poulsen LK, Søndergaard I, Weeke B. Improvement of specific immunotherapy by human IgG and modified allergens. *Allergy*. 1989;44(4):241-255.
428. Eichhorn S, Hörschläger A, Steiner M, et al. Rational Design, Structure-Activity Relationship, and Immunogenicity of Hypoallergenic Pru p 3 Variants. *Mol Nutr Food Res*. 2019;63(18):e1900336.
429. Zuidmeer-Jongejan L, Huber H, Swoboda I, et al. Development of a hypoallergenic recombinant parvalbumin for first-in-man subcutaneous immunotherapy of fish allergy. *Int Arch Allergy Immunol*. 2015;166(1):41-51.
430. Swoboda I, Bugajska-Schretter A, Linhart B, et al. A recombinant hypoallergenic parvalbumin mutant for immunotherapy of IgE-mediated fish allergy. *J Immunol*. 2007;178(10):6290-6296.
431. Senti G, Cramer R, Kuster D, et al. Intralymphatic immunotherapy for cat allergy induces tolerance after only 3 injections. *J Allergy Clin Immunol*. 2012;129(5):1290-1296.
432. Zaleska A, Eiwegger T, Soyer O, et al. Immune regulation by intralymphatic immunotherapy with modular allergen translocation MAT vaccine. *Allergy*. 2014;69(9):1162-1170.
433. Orengo JM, Radin AR, Kamat V, et al. Treating cat allergy with monoclonal IgG antibodies that bind allergen and prevent IgE engagement. *Nat Commun*. 2018;9(1):1421.
434. Kurosaka A, Yano A, Itoh N, Kuroda Y, Nakagawa T, Kawasaki T. The structure of a neural specific carbohydrate epitope of horseradish peroxidase recognized by anti-horseradish peroxidase antiserum. *J Biol Chem*. 1991;266(7):4168-4172.
435. Tretter V, Altmann F, Kubelka V, März L, Becker WM. Fucose alpha 1,3-linked to the core region of glycoprotein N-glycans creates an important epitope for IgE from honeybee venom allergic individuals. *Int Arch Allergy Immunol*. 1993;102(3):259-266.
436. Bencúrová M, Hemmer W, Focke-Tejkl M, Wilson IB, Altmann F. Specificity of IgG and IgE antibodies against plant and insect glycoprotein glycans determined with artificial glycoforms of human transferrin. *Glycobiology*. 2004;14(5):457-466.
437. Crispell G, Commins SP, Archer-Hartman SA, et al. Discovery of Alpha-Gal-Containing Antigens in North American Tick Species Believed to Induce Red Meat Allergy. *Front Immunol*. 2019;10:1056.
438. Steinke JW, Platts-Mills TA, Commins SP. The alpha-gal story: lessons learned from connecting the dots. *J Allergy Clin Immunol*. 2015;135(3):589-596. quiz 597.
439. Mari A. IgE to cross-reactive carbohydrate determinants: analysis of the distribution and appraisal of the *in vivo* and *in vitro* reactivity. *Int Arch Allergy Immunol*. 2002;129(4):286-295.
440. Batanero E, Crespo JF, Monsalve RI, Martín-Esteban M, Villalba M, Rodríguez R. IgE-binding and histamine-release capabilities of the main carbohydrate component isolated from the major allergen of olive tree pollen, Ole e 1. *J Allergy Clin Immunol*. 1999;103(1 Pt 1):147-153.
441. Fötisch K, Altmann F, Hausteiner D, Vieths S. Involvement of carbohydrate epitopes in the IgE response of celery-allergic patients. *Int Arch Allergy Immunol*. 1999;120(1):30-42.
442. Iacovacci P, Afferni C, Butteroni C, et al. Comparison between the native glycosylated and the recombinant Cup a1 allergen: role of carbohydrates in the histamine release from basophils. *Clin Exp Allergy*. 2002;32(11):1620-1627.
443. Holzweber F, Svehla E, Fellner W, et al. Inhibition of IgE binding to cross-reactive carbohydrate determinants enhances diagnostic selectivity. *Allergy*. 2013;68(10):1269-1277.
444. Altmann F. Basophil activation test is better but not good enough for the diagnosis of hymenoptera venom allergy: the problem of cross-reactive carbohydrate determinants. *Clin Exp Allergy*. 2010;40:1290-1292.
445. Mertens M, Amler S, Moerschbacher BM, Brehler R. Cross-reactive carbohydrate determinants strongly affect the results of the basophil activation test in hymenoptera-venom allergy. *Clin Exp Allergy*. 2010;40(9):1333-1345.
446. Jin C, Hantusch B, Hemmer W, Stadlmann J, Altmann F. Affinity of IgE and IgG against cross-reactive carbohydrate determinants on plant and insect glycoproteins. *J Allergy Clin Immunol*. 2008;121(1):185-190.e182.
447. Homann A, Schramm G, Jappe U. Glycans and glycan-specific IgE in clinical and molecular allergology: Sensitization, diagnostics, and clinical symptoms. *J Allergy Clin Immunol*. 2017;140(2):356-368.
448. Wilson IB, Altmann F. Structural analysis of N-glycans from allergenic grass, ragweed and tree pollens: core alpha1,3-linked fucose and xylose present in all pollens examined. *Glycoconj J*. 1998;15(11):1055-1070.
449. Koprivova AAF, Gorr K, et al. N-glycosylation in the moss *Physcomitrella patens* is organized similarly to that in higher plants. *Plant Biol*. 2003;5:582-591.
450. Paschinger K, Wilson IBH. Comparisons of N-glycans across invertebrate phyla. *Parasitology*. 2019;146(14):1733-1742.
451. Van Ree RAM. Pollen-vegetable food crossreactivity: serological and clinical relevance of crossreactive IgE. *J Clin Immunoassay*. 1993;16:124-130.
452. Ollert M, Blank S. Anaphylaxis to insect venom allergens: role of molecular diagnostics. *Curr Allergy Asthma Rep*. 2015;15(5):26.
453. Linneberg A, Fenger RV, Husemoen LL, Vidal C, Vizcaino L, Gonzalez-Quintela A. Immunoglobulin E sensitization to cross-reactive carbohydrate determinants: epidemiological study of clinical relevance and role of alcohol consumption. *Int Arch Allergy Immunol*. 2010;153(1):86-94.
454. Gattinger P, Mittermann I, Lupinek C, et al. Recombinant glycoproteins resembling carbohydrate-specific IgE epitopes from plants, venoms and mites. *EBioMedicine*. 2019;39:33-43.
455. Wollmann E, Hamsten C, Sibanda E, et al. Natural clinical tolerance to peanut in African patients is caused by poor allergenic activity of peanut IgE. *Allergy*. 2015;70(6):638-652.
456. Cabauatan CR, Lupinek C, Scheiblhofer S, et al. Allergen microarray detects high prevalence of asymptomatic IgE sensitizations to tropical pollen-derived carbohydrates. *J Allergy Clin Immunol*. 2014;133(3):910-914.e915.
457. Matricardi PM. IgE to cross-reactive carbohydrate determinants: Origins, functions, and confounding role in nPhl p 4-IgE assays. *J Allergy Clin Immunol*. 2020;145(6):1554-1555.
458. Hemmer W, Focke M, Kolarich D, Dalik I, Götz M, Jarisch R. Identification by immunoblot of venom glycoproteins displaying immunoglobulin E-binding N-glycans as cross-reactive allergens in honeybee and yellow jacket venom. *Clin Exp Allergy*. 2004;34(3):460-469.
459. Jappe U, Raulf-Heimsoth M, Hoffmann M, Burow G, Hübsch-Müller C, Enk A. *In vitro* hymenoptera venom allergy diagnosis: improved by screening for cross-reactive carbohydrate determinants and reciprocal inhibition. *Allergy*. 2006;61(10):1220-1229.
460. Gattinger P, Bidovec-Stojkovic U, Zidarn M, Korosec P, Valenta R, Mittermann I. Glycosylation enhances allergenic activity of major bee venom allergen Api m 1 by adding IgE epitopes. *J Allergy Clin Immunol*. 2021;147(4):1502-1504.e1505.
461. Nkurungi G, van Diepen A, Nassuuna J, et al. Microarray assessment of N-glycan-specific IgE and IgG profiles associated with *Schistosoma mansoni* infection in rural and urban Uganda. *Sci Rep*. 2019;9(1):3522.
462. Ebo DG, Lechkar B, Schuerwegh AJ, Bridts CH, De Clerck LS, Stevens WJ. Validation of a two-color flow cytometric assay detecting *in vitro* basophil activation for the diagnosis of IgE-mediated natural rubber latex allergy. *Allergy*. 2002;57(8):706-712.
463. Recke ALZD, Ernst M, et al. Hymenopterengift-allergie: diagnostisches vorgehen bei IgE-doppelpositivität gegen Gifte unterschiedlicher spezies. *Allergologie*. 2013;36:415-419.
464. Virtanen T. Inhalant mammal-derived lipocalin allergens and the innate immunity. *Front Allergy*. 2021;2:824736.

465. Le Maux S, Bouhallab S, Giblin L, Brodkorb A, Croguennec T. Bovine β -lactoglobulin/fatty acid complexes: binding, structural, and biological properties. *Dairy Sci Technol*. 2014;94:409-426.
466. Roth-Walter F, Afify SM, Pacios LF, et al. Cow's milk protein β -lactoglobulin confers resilience against allergy by targeting complexed iron into immune cells. *J Allergy Clin Immunol*. 2021;147(1):321-334. e324.
467. Kofler S, Asam C, Eckhard U, Wallner M, Ferreira F, Brandstetter H. Crystallographically mapped ligand binding differs in high and low IgE binding isoforms of birch pollen allergen bet v 1. *J Mol Biol*. 2012;422(1):109-123.
468. Afify SM, Pali-Schöll I, Hufnagl K, et al. Bovine Holo-Beta-Lactoglobulin Cross-Protects Against Pollen Allergies in an Innate Manner in BALB/c Mice: Potential Model for the Farm Effect. *Front Immunol*. 2021;12:611474.
469. Chruszcz M, Chew FT, Hoffmann-Sommergruber K, et al. Allergens and their associated small molecule ligands-their dual role in sensitization. *Allergy*. 2021;76(8):2367-2382.
470. Offermann LR, Chan SL, Osinski T, et al. The major cockroach allergen Bla g 4 binds tyramine and octopamine. *Mol Immunol*. 2014;60(1):86-94.
471. Mueller GA, Benjamin DC, Rule GS. Tertiary structure of the major house dust mite allergen Der p 2: sequential and structural homologies. *Biochemistry*. 1998;37(37):12707-12714.
472. Mueller GA, Pedersen LC, Lih FB, et al. The novel structure of the cockroach allergen Bla g 1 has implications for allergenicity and exposure assessment. *J Allergy Clin Immunol*. 2013;132(6):1420-1426.
473. Foo ACY, Thompson PM, Perera L, et al. Hydrophobic ligands influence the structure, stability, and processing of the major cockroach allergen Bla g 1. *Sci Rep*. 2019;9(1):18294.
474. Satitsuksanoa P, Kennedy M, Gilis D, et al. The minor house dust mite allergen Der p 13 is a fatty acid-binding protein and an activator of a TLR2-mediated innate immune response. *Allergy*. 2016;71(10):1425-1434.
475. Spangfort MD, Mirza O, Ipsen H, Van Neerven RJ, Gajhede M, Larsen JN. Dominating IgE-binding epitope of Bet v 1, the major allergen of birch pollen, characterized by X-ray crystallography and site-directed mutagenesis. *J Immunol*. 2003;171(6):3084-3090.
476. Soh WT, Aglas L, Mueller GA, et al. Multiple roles of Bet v 1 ligands in allergen stabilization and modulation of endosomal protease activity. *Allergy*. 2019;74(12):2382-2393.
477. Hilger C, van Hage M, Kuehn A. Diagnosis of Allergy to Mammals and Fish: Cross-Reactive vs. *Specific Markers Curr Allergy Asthma Rep*. 2017;17(9):64.
478. Zhu J, Guo M, Ban L, et al. Niemann-Pick C2 Proteins: A New Function for an Old Family. *Front Physiol*. 2018;9:52.
479. Jappe U, Schwager C, Schromm AB, et al. Lipophilic allergens, different modes of allergen-lipid interaction and their impact on asthma and allergy. *Front Immunol*. 2019;10:122.
480. Bublin M, Eiwegger T, Breiteneder H. Do lipids influence the allergic sensitization process? *J Allergy Clin Immunol*. 2014;134(3):521-529.
481. Salminen TA, Blomqvist K, Edqvist J. Lipid transfer proteins: classification, nomenclature, structure, and function. *Planta*. 2016;244(5):971-997.
482. Dubiela P, Aina R, Polak D, et al. Enhanced Pru p 3 IgE-binding activity by selective free fatty acid-interaction. *J Allergy Clin Immunol*. 2017;140(6):1728-1731.e1710.
483. Gonzalez-Klein Z, Cuevas-Zuñiga B, Wangorsch A, et al. The key to the allergenicity of lipid transfer protein (LTP) ligands: A structural characterization. *Biochim Biophys Acta Mol Cell Biol Lipids*. 1866;2021(7):158928.
484. Cubells-Baeza N, Gómez-Casado C, Tordesillas L, et al. Identification of the ligand of Pru p 3, a peach LTP. *Plant Mol Biol*. 2017;94(1-2):33-44.
485. Tordesillas L, Cubells-Baeza N, Gómez-Casado C, et al. Mechanisms underlying induction of allergic sensitization by Pru p 3. *Clin Exp Allergy*. 2017;47(11):1398-1408.
486. Del Moral MG, Martínez-Naves E. The Role of Lipids in Development of Allergic Responses. *Immune Netw*. 2017;17(3):133-143.
487. Scheurer S, Schülke S. Interaction of Non-Specific Lipid-Transfer Proteins With Plant-Derived Lipids and Its Impact on Allergic Sensitization. *Front Immunol*. 2018;9:1389.
488. Agea E, Russano A, Bistoni O, et al. Human CD1-restricted T cell recognition of lipids from pollens. *J Exp Med*. 2005;202(2):295-308.
489. Gunawan H, Takai T, Kamijo S, et al. Characterization of proteases, proteins, and eicosanoid-like substances in soluble extracts from allergenic pollen grains. *Int Arch Allergy Immunol*. 2008;147(4):276-288.
490. Oeder S, Alessandrini F, Wirz OF, et al. Pollen-derived nonallergenic substances enhance Th2-induced IgE production in B cells. *Allergy*. 2015;70(11):1450-1460.
491. Platts-Mills TA, Vervloet D, Thomas WR, Aalberse RC, Chapman MD. Indoor allergens and asthma: report of the Third International Workshop. *J Allergy Clin Immunol*. 1997;100(6 Pt 1):S2-S24.
492. Gold DR, Adamkiewicz G, Arshad SH, et al. NIAID, NIEHS, NHLBI, and MCAN Workshop Report: The indoor environment and childhood asthma-implications for home environmental intervention in asthma prevention and management. *J Allergy Clin Immunol*. 2017;140(4):933-949.
493. Pfaar O, Bergmann KC, Bonini S, et al. Technical standards in allergen exposure chambers worldwide - an EAACI Task Force Report. *Allergy*. 2021;76(12):3589-3612.
494. Blom WM, Michelsen-Huisman AD, van Os-Medendorp H, et al. Accidental food allergy reactions: Products and undeclared ingredients. *J Allergy Clin Immunol*. 2018;142(3):865-875.
495. Buters J, Prank M, Sofiev M, et al. Variation of the group 5 grass pollen allergen content of airborne pollen in relation to geographic location and time in season. *J Allergy Clin Immunol*. 2015;136(1):87-95.
496. Mindaye ST, Sun C, Esfahani SAZ, et al. Diversity and complexity of mouse allergens in urine, house dust, and allergen extracts assessed with an immuno-allergomic approach. *Allergy*. 2021;76(12):3723-3732.
497. Pilolli R, Nitride C, Gillard N, et al. Critical review on proteotypic peptide marker tracing for six allergenic ingredients in incurred foods by mass spectrometry. *Food Res Int*. 2020;128:108747.
498. Sander I, Zahradnik E, Kraus G, et al. Domestic mite antigens in floor and airborne dust at workplaces in comparison to living areas: a new immunoassay to assess personal airborne allergen exposure. *PLoS One*. 2012;7(12):e52981.
499. Platts-Mills J, Custis N, Kenney A, et al. The effects of cage design on airborne allergens and endotoxin in animal rooms: high-volume measurements with an ion-charging device. *Contemp Top Lab Anim Sci*. 2005;44(2):12-16.
500. Mason HJ, Laura W. Airborne exposure to laboratory animal allergens. *AIMS Allergy Immunol*. 2017;1:78-88. doi:10.3934/Allergy.2017.2.78
501. Sander I, Lotz A, Neumann HD, Czibor C, Zahradnik E, Raulf M. Reliability and Correlation Between Indoor Allergen Concentrations from Vacuumed Surface Samples and Electrostatic Dust Collectors. *Ann Work Expo Health*. 2020;64(2):165-174.
502. Richardson M, Gottel N, Gilbert JA, et al. Concurrent measurement of microbiome and allergens in the air of bedrooms of allergy disease patients in the Chicago area. *Microbiome*. 2019;7(1):82.
503. Remington BC, Taylor SL, Marx DB, Petersen BJ, Baumert JL. Soy in wheat-contamination levels and food allergy risk assessment. *Food Chem Toxicol*. 2013;62:485-491.
504. Bedford B, Yu Y, Wang X, Garber EA, Jackson LS. A Limited Survey of Dark Chocolate Bars Obtained in the United States for Undeclared Milk and Peanut Allergens. *J Food Prot*. 2017;80(4):692-702.

505. Chapman MD. In: Leung DYM, Sampson HA, Geha R, Szeffler SJ, eds. *Indoor Allergens, in Pediatric Allergy: Principles and Practice*. Second ed. Saunders Elsevier; 2010:266-273.
506. Pomés A, Mueller GA, Chruszcz M. Structural Aspects of the Allergen-Antibody Interaction. *Front Immunol*. 2020;11:2067.
507. Mueller GA, Glesner J, Daniel JL, et al. Mapping Human Monoclonal IgE Epitopes on the Major Dust Mite Allergen Der p 2. *J Immunol*. 2020;205(8):1999-2007.
508. King EM, Filep S, Smith B, et al. A multi-center ring trial of allergen analysis using fluorescent multiplex array technology. *J Immunol Methods*. 2013;387(1-2):89-95.
509. Salo PM, Wilkerson J, Rose KM, et al. Bedroom allergen exposures in US households. *J Allergy Clin Immunol*. 2018;141(5):1870-1879.
510. Geng T, Liu K, Frazier R, et al. Development of a Sandwich ELISA for Quantification of Gly m 4, a Soybean Allergen. *J Agric Food Chem*. 2015;63(20):4947-4953.
511. Filep S, Block DS, Smith BRE, et al. Specific allergen profiles of peanut foods and diagnostic or therapeutic allergenic products. *J Allergy Clin Immunol*. 2018;141(2):626-631.
512. Hindley JP, Filep S, Block DS, King EM, Chapman MD. Dose of allergens in a peanut snack (Bamba) associated with prevention of peanut allergy. *J Allergy Clin Immunol*. 2018;141(2):780-782.
513. Nimata M, Okada H, Kurihara K, et al. A harmonized immunoassay with liquid chromatography-mass spectrometry analysis in egg allergen determination. *Anal Bioanal Chem*. 2018;410(2):325-335.
514. Ueberham E, Spiegel H, Havenith H, et al. Simplified Tracking of a Soy Allergen in Processed Food Using a Monoclonal Antibody-Based Sandwich ELISA Targeting the Soybean 2S Albumin Gly m 8. *J Agric Food Chem*. 2019;67(31):8660-8667.
515. Holzhauser T, Franke A, Treudler R, et al. The BASALIT multicenter trial: Gly m 4 quantification for consistency control of challenge meal batches and toward Gly m 4 threshold data. *Mol Nutr Food Res*. 2017;61(3).
516. Foetisch K, Dahl L, Jansen B, et al. Development and in-house validation of allergen-specific ELISA tests for the quantification of Dau c 1.01, Dau c 1.02 and Dau c 4 in carrot extracts (*Daucus carota*). *Anal Bioanal Chem*. 2011;399(2):935-943.
517. Foetisch K, Scheurer S, Vieths S, Hanschmann KM, Lidholm J, Mahler V. Identification of allergen-resolved threshold doses of carrot (*Daucus carota*) by means of oral challenge and ELISA. *J Allergy Clin Immunol*. 2013;131(6):1711-1713.
518. Food Allergy Safety, Treatment, Education, and Research Act of 2021., in Pub. L. No. 117-11, 135 Stat. 262.V.
519. European Parliament Regulation (EU). No 1169/2011 of the European parliament and of the council of 25 October 2011 on the provision of food information to consumers, amending Regulations (EC) No 1924/2006 and (EC) No 1925/2006 of the European Parliament and of the Council, and repealing Commission Directive 87/250/EEC, Council Directive 90/496/EEC, Commission Directive 1999/10/EC, Directive 2000/13/EC of the European Parliament and of the Council, Commission Directives 2002/67/EC and 2008/5/EC and Commission Regulation (EC) No 608/2004. *Off. J. Eur. Union*. 2011;L304:18-63.
520. Filep S, Chapman MD. Doses of Specific Allergens in Early Introduction Foods for Prevention of Food Allergy. *J Allergy Clin Immunol Pract*. 2022;10(1):150-158.
521. Commins SP. Allergen Sold Separately? All Early Allergen Introduction Foods Are Not Equivalent. *J Allergy Clin Immunol Pract*. 2022;10(1):159-160.
522. Sheehan WJ, Permaul P, Petty CR, et al. Association Between Allergen Exposure in Inner-City Schools and Asthma Morbidity Among Students. *JAMA Pediatr*. 2017;171(1):31-38.
523. Maciag MC, Sheehan WJ, Bartnikas LM, et al. Detection of Food Allergens in School and Home Environments of Elementary Students. *J Allergy Clin Immunol Pract*. 2021;9(10):3735-3743.
524. Brough HA, Mills ENC, Richards K, Lack G, Johnson PE. Mass spectrometry confirmation that clinically important peanut protein allergens are present in household dust. *Allergy*. 2020;75(3):709-712.
525. Walker MJ, Burns M, Quaglia M, et al. Almond or Mahaleb? Orthogonal Allergen Analysis During a Live Incident Investigation by ELISA, Molecular Biology, and Protein Mass Spectrometry. *J AOAC Int*. 2018;101(1):162-169.
526. Holzhauser TJP, Hindley JP, et al. Are current analytical methods suitable to verify VITAL® 2.0/3.0 allergen reference doses for EU allergens in foods? *Food Chem Toxicol*. 2020;145:111709. doi:10.1016/j.fct.2020.111709
527. Nowatzke WL, Oliver KG, Cho CY, Rallabhandi P, Garber EAE. Single-Laboratory Validation of the Multiplex xMAP Food Allergen Detection Assay with Incurred Food Samples. *J Agric Food Chem*. 2019;67(1):484-498.
528. New LS, Schreiber A, Stahl-Zeng J, Liu HF. Simultaneous Analysis of Multiple Allergens in Food Products by LC-MS/MS. *J AOAC Int*. 2018;101(1):132-145.
529. Monaci L, Pilolli R, De Angelis E, Crespo JF, Novak N, Cabanillas B. Food allergens: Classification, molecular properties, characterization, and detection in food sources. *Adv Food Nutr Res*. 2020;93:113-146.
530. Xiong W, Parker CH, Boo CC, Fiedler KL. Comparison of allergen quantification strategies for egg, milk, and peanut in food using targeted LC-MS/MS. *Anal Bioanal Chem*. 2021;413(23):5755-5766.
531. New LS, Stahl-Zeng J, Schreiber A, et al. Detection and Quantitation of Selected Food Allergens by Liquid Chromatography with Tandem Mass Spectrometry: First Action 2017.17. *J AOAC Int*. 2020;103(2):570-583.
532. Planque M, Arnould T, Dieu M, Delahaut P, Renard P, Gillard N. Liquid chromatography coupled to tandem mass spectrometry for detecting ten allergens in complex and incurred foodstuffs. *J Chromatogr A*. 2017;1530:138-151.
533. Martinez-Esteso MJ, O'Connor G, Nørgaard J, et al. A reference method for determining the total allergenic protein content in a processed food: the case of milk in cookies as proof of concept. *Anal Bioanal Chem*. 2020;412(30):8249-8267.
534. Custovic A. To what extent is allergen exposure a risk factor for the development of allergic disease? *Clin Exp Allergy*. 2015;45(1):54-62.
535. Almqvist C, Egmar AC, Hedlin G, et al. Direct and indirect exposure to pets - risk of sensitization and asthma at 4 years in a birth cohort. *Clin Exp Allergy*. 2003;33(9):1190-1197.
536. Lau S, Illi S, Sommerfeld C, et al. Early exposure to house-dust mite and cat allergens and development of childhood asthma: a cohort study. *Lancet*. 2000;356(9239):1392-1397.
537. Ihuoma H, Belgrave DC, Murray CS, Foden P, Simpson A, Custovic A. Cat ownership, cat allergen exposure, and trajectories of sensitization and asthma throughout childhood. *J Allergy Clin Immunol*. 2018;141(2):820-822.
538. Brough HA, Simpson A, Makinson K, et al. Peanut allergy: effect of environmental peanut exposure in children with filaggrin loss-of-function mutations. *J Allergy Clin Immunol*. 2014;134(4):867-875.
539. Simpson A, Brough HA, Haider S, Belgrave D, Murray CS, Custovic A. Early-life inhalant allergen exposure, filaggrin genotype, and the development of sensitization from infancy to adolescence. *J Allergy Clin Immunol*. 2020;145(3):993-1001.
540. Lynch SV, Wood RA, Boushey H, et al. Effects of early-life exposure to allergens and bacteria on recurrent wheeze and atopy in urban children. *J Allergy Clin Immunol*. 2014;134(3):593-601.
541. Simpson A, John SL, Jury F, et al. Endotoxin exposure, CD14, and allergic disease: an interaction between genes and the environment. *Am J Respir Crit Care Med*. 2006;174(4):386-392.
542. Gergen PJ, Mortimer KM, Eggleston PA, et al. Results of the National Cooperative Inner-City Asthma Study (NCICAS)

- environmental intervention to reduce cockroach allergen exposure in inner-city homes. *J Allergy Clin Immunol.* 1999;103(3 Pt 1):501-506.
543. Murray CS, Poletti G, Kebabze T, et al. Study of modifiable risk factors for asthma exacerbations: virus infection and allergen exposure increase the risk of asthma hospital admissions in children. *Thorax.* 2006;61(5):376-382.
544. Heymann PW, Platts-Mills TA. Deciphering the importance of host and environmental factors that influence the genesis of asthma during childhood. *J Infect Dis.* 2012;206:1331-1333.
545. Zuiani C, Custovic A. Update on House Dust Mite Allergen Avoidance Measures for Asthma. *Curr Allergy Asthma Rep.* 2020;20(9):50.
546. Wilson JM, Platts-Mills TAE. Home Environmental Interventions for House Dust Mite. *J Allergy Clin Immunol Pract.* 2018;6(1):1-7.
547. Murray CS, Foden P, Sumner H, Shepley E, Custovic A, Simpson A. Preventing Severe Asthma Exacerbations in Children. A Randomized Trial of Mite-Impermeable Bedcovers. *Am J Respir Crit Care Med.* 2017;196(2):150-158.
548. Shirai T, Matsui T, Suzuki K, Chida K. Effect of pet removal on pet allergic asthma. *Chest.* 2005;127(5):1565-1571.
549. Cloutier MM, Baptist AP, Blake KV, et al. 2020 Focused Updates to the Asthma Management Guidelines: A Report from the National Asthma Education and Prevention Program Coordinating Committee Expert Panel Working Group. *J Allergy Clin Immunol.* 2020;146(6):1217-1270.
550. Scott M, Roberts G, Kurukulaaratchy RJ, Matthews S, Nove A, Arshad SH. Multifaceted allergen avoidance during infancy reduces asthma during childhood with the effect persisting until age 18 years. *Thorax.* 2012;67(12):1046-1051.
551. Lowe L, Murray CS, Martin L, et al. Reported versus confirmed wheeze and lung function in early life. *Arch Dis Child.* 2004;89(6):540-543.
552. Vieths S, Barber D, Chapman M, et al. Establishment of recombinant major allergens Bet v 1 and Phl p 5a as Ph. Eur. reference standards and validation of ELISA methods for their measurement. Results from feasibility studies. *Pharmeur Bio Sci Notes.* 2012;2012:118-134.
553. Zimmer J, Bridgewater J, Ferreira F, van Ree R, Rabin RL, Vieths S. The History, Present and Future of Allergen Standardization in the United States and Europe. *Front Immunol.* 2021;12:725831.
554. Houben GF, Baumert JL, Blom WM, et al. Full range of population Eliciting Dose values for 14 priority allergenic foods and recommendations for use in risk characterization. *Food Chem Toxicol.* 2020;146:111831.
555. Mills ENC, Adel-Patient K, Bernard H, et al. Detection and Quantification of Allergens in Foods and Minimum Eliciting Doses in Food-Allergic Individuals (ThRAIL). *J AOAC Int.* 2019;102(5):1346-1353.
556. Stoyke M, Becker R, Brockmeyer J, et al. German Government Official Methods Board Points the Way Forward: Launch of a New Working Group for Mass Spectrometry for Protein Analysis to Detect Food Fraud and Food Allergens. *J AOAC Int.* 2019;102(5):1280-1285.
557. Gergen PJ, Mitchell HE, Calatroni A, et al. Sensitization and Exposure to Pets: The Effect on Asthma Morbidity in the US Population. *J Allergy Clin Immunol Pract.* 2018;6(1):101-107.
558. Sheehan WJ, Taylor SL, Phipatanakul W, et al. Environmental food exposure: what is the risk of clinical reactivity from cross-contact and what is the risk of sensitization. *J Allergy Clin Immunol Pract.* 2018;6:1825-1832.
559. Tuppo L, Alessandri C, Pomponi D, et al. Peamaclein—a new peach allergenic protein: similarities, differences and misleading features compared to Pru p 3. *Clin Exp Allergy.* 2013;43(1):128-140.
560. Scutt CP, Vandenbussche M. Current trends and future directions in flower development research. *Ann Bot.* 2014;114(7):1399-1406.
561. Asam C, Hofer H, Wolf M, Aglas L, Wallner M. Tree pollen allergens—an update from a molecular perspective. *Allergy.* 2015;70(10):1201-1211.
562. Movérare R, Westritschnig K, Svensson M, et al. Different IgE reactivity profiles in birch pollen-sensitive patients from six European populations revealed by recombinant allergens: an imprint of local sensitization. *Int Arch Allergy Immunol.* 2002;128(4):325-335.
563. Biedermann T, Winther L, Till SJ, Panzner P, Knulst A, Valovirta E. Birch pollen allergy in Europe. *Allergy.* 2019;74(7):1237-1248.
564. Kolek F, MDP P, Leier-Wirtz V, Friedmann A, Traidl-Hoffmann C, Damialis A. Earlier Flowering of *Betula pendula* Roth in Augsburg, Germany, Due to Higher Temperature, NO₂ and Urbanity, and Relationship with *Betula* spp. Pollen Season. *Int J Environ Res Public Health.* 2021;18(19).
565. Kirmaz C, Yuksel H, Bayrak P, Yilmaz O. Symptoms of the olive pollen allergy: do they really occur only in the pollination season? *J Investig Allergol Clin Immunol.* 2005;15(2):140-145.
566. Quiralte J, Florido F, Arias de Saavedra JM, et al. Olive allergen-specific IgE responses in patients with *Olea europaea* pollinosis. *Allergy.* 2002;57 Suppl 71:47-52.
567. Scala E, Abeni D, Pomponi D, et al. Ole e 1, Ole e 7, and Ole e 9: Identifying distinct clinical subsets of olive tree-allergic patients. *J Allergy Clin Immunol.* 2016;137(2):629-631.e623.
568. Scala E, Villalta D, Uasuf CG, et al. An atlas of IgE sensitization patterns in different Italian areas. A multicenter, cross-sectional study. *Eur Ann Allergy Clin Immunol.* 2018;50(5):217-225.
569. D'Amato G, Cecchi L, Bonini S, et al. Allergenic pollen and pollen allergy in Europe. *Allergy.* 2007;62(9):976-990.
570. De Linares C, Plaza MP, Valle AM, Alcázar P, Díaz de la Guardia C, Galán C. Airborne cupressaceae pollen and its major allergen, Cup a 1, in Urban Green Areas of Southern Iberian Peninsula. *Forests.* 2021;12:254. doi:10.3390/f12020254
571. Alcázar P, Cariñanos P, De Castro C, et al. Airborne plane-tree (*Platanus hispanica*) pollen distribution in the city of Córdoba, South-western Spain, and possible implications on pollen allergy. *J Investig Allergol Clin Immunol.* 2004;14(3):238-243.
572. Mansouritorghabeh H, Jabbari-Azad F, Sankian M, Varasteh A, Farid-Hosseini R. The Most Common Allergenic Tree Pollen Grains in the Middle East: A Narrative Review. *Iran J Med Sci.* 2019;44(2):87-98.
573. AlKhater SA. Sensitization to Common Aeroallergens in Asthmatic Children in the Eastern Region of Saudi Arabia. *Saudi J Med Med Sci.* 2017;5(2):136-141.
574. Niederberger V, Pauli G, Grönlund H, et al. Recombinant birch pollen allergens (rBet v 1 and rBet v 2) contain most of the IgE epitopes present in birch, alder, hornbeam, hazel, and oak pollen: a quantitative IgE inhibition study with sera from different populations. *J Allergy Clin Immunol.* 1998;102(4 Pt 1):579-591.
575. Gilles S, Blume C, Wimmer M, et al. Pollen exposure weakens innate defense against respiratory viruses. *Allergy.* 2020;75(3):576-587.
576. Damialis A, Gilles S, Sofiev M, et al. Higher airborne pollen concentrations correlated with increased SARS-CoV-2 infection rates, as evidenced from 31 countries across the globe. *Proc Natl Acad Sci U S A.* 2021;118(12).
577. Breiteneder H, Hassfeld W, Pettenburger K, et al. Isolation and characterization of messenger RNA from male inflorescences and pollen of the white birch (*Betula verrucosa*). *Int Arch Allergy Appl Immunol.* 1988;87(1):19-24.
578. Valenta R, Duchêne M, Vrtala S, et al. Profilin, a Novel Plant Pan-Allergen. *Int Arch Allergy Immunol.* 1992;99(2-4):271-273.
579. Asero R, Jimeno L, Barber D. Preliminary results of a skin prick test-based study of the prevalence and clinical impact of hypersensitivity to pollen panallergens (polcalcin and profilin). *J Investig Allergol Clin Immunol.* 2010;20(1):35-38.

580. Ciprandi G, Comite P, Mussap M, et al. Profiles of Birch Sensitization (Bet v 1, Bet v 2, and Bet v 4) and Oral Allergy Syndrome Across Italy. *J Investig Allergol Clin Immunol*. 2016;26(4):244-248.
581. Karamloo F, Schmitz N, Scheurer S, et al. Molecular cloning and characterization of a birch pollen minor allergen, Bet v 5, belonging to a family of isoflavone reductase-related proteins. *J Allergy Clin Immunol*. 1999;104(5):991-999.
582. Mahler V, Fischer S, Heiss S, Duchêne M, Kraft D, Valenta R. cDNA cloning and characterization of a cross-reactive birch pollen allergen: identification as a pectin esterase. *Int Arch Allergy Immunol*. 2001;124(1-3):64-66.
583. Rodríguez R, Villalba M, Monsalve RI, Batanero E. The spectrum of olive pollen allergens. *Int Arch Allergy Immunol*. 2001;125(3):185-195.
584. Duffort O, Palomares O, Lombardero M, et al. Variability of Ole e 9 allergen in olive pollen extracts: relevance of minor allergens in immunotherapy treatments. *Int Arch Allergy Immunol*. 2006;140(2):131-138.
585. Barber D, de la Torre F, Feo F, et al. Understanding patient sensitization profiles in complex pollen areas: a molecular epidemiological study. *Allergy*. 2008;63(11):1550-1558.
586. Scala E, Abeni D, Guerra EC, et al. β -1,3-glucanase rOle e 9 and MnSOD rAsp f 6 IgE reactivity are the signature of atopic dermatitis in the Mediterranean area. *Clin Exp Allergy*. 2020;50(4):487-498.
587. Ali-Sadeghi H, Khodadadi A, Amini A, Assarehzadegan MA, Sepahi N, Zarinhadideh F. Proj 2 is mesquite profilin: molecular characteristics and specific IgE binding activity. *Asian Pac J Allergy Immunol*. 2015;33(2):90-98.
588. Dousti F, Assarehzadegan MA, Morakabati P, Khosravi GR, Akbari B. Molecular Cloning and Expression of Pro J 1: A New Allergen of Prosopis Juliflora Pollen. *Iran J Allergy Asthma Immunol*. 2016;15(2):122-131.
589. Khosravi GR, Assarehzadegan MA, Morakabati P, Akbari B, Dousti F. Cloning and expression of Aca f 1: a new allergen of Acacia farnesiana pollen. *Cent Eur J Immunol*. 2016;41(3):273-281.
590. Di Felice G, Barletta B, Tinghino R, Pini C. Cupressaceae pollinosis: identification, purification and cloning of relevant allergens. *Int Arch Allergy Immunol*. 2001;125(4):280-289.
591. Tuppo L, Alessandri C, Giangrieco I, et al. Isolation of cypress gibberellin-regulated protein: Analysis of its structural features and IgE binding competition with homologous allergens. *Mol Immunol*. 2019;114:189-195.
592. Asero R, Abbadessa S, Aruanno A, et al. Sensitization to Gibberellin-Regulated Protein (Peamaclein) Among Italian Cypress Pollen-Sensitized Patients. *J Investig Allergol Clin Immunol*. 2021;32(1):40-47.
593. Asturias JA, Ibarrola I, Bartolomé B, Ojeda I, Malet A, Martínez A. Purification and characterization of Pla a 1, a major allergen from Platanus acerifolia pollen. *Allergy*. 2002;57(3):221-227.
594. Scala E, Cecchi L, Abeni D, et al. Pla a 2 and Pla a 3 reactivities identify plane tree-allergic patients with respiratory symptoms or food allergy. *Allergy*. 2017;72(4):671-674.
595. Danella Figo D, De Amicis K, Neiva Santos de Aquino D, et al. Cashew Tree Pollen: An Unknown Source of IgE-Reactive Molecules. *Int J Mol Sci*. 2019;20(10).
596. Victorio Puche L, Somoza ML, López-Sánchez JD, Garrido-Arandia M, Díaz-Perales A, Blanca M. Peach Tree Pollen and Prunus persica 9 Sensitisation and Allergy in Children and Adolescents. *Int Arch Allergy Immunol*. 2019;180(3):212-220.
597. D'Amato G, Spiekma FT, Liccardi G, et al. Pollen-related allergy in Europe. *Allergy*. 1998;53(6):567-578.
598. Blanca M, Victorio Puche L, Garrido-Arandia M, et al. Pru p 9, a new allergen eliciting respiratory symptoms in subjects sensitized to peach tree pollen. *PLoS One*. 2020;15(3):e0230010.
599. Scala E, Abeni D, Cecchi L, et al. Molecular Recognition Profiles and Clinical Patterns of PR-10 Sensitization in a Birch-Free Mediterranean Area. *Int Arch Allergy Immunol*. 2017;173(3):138-146.
600. Asero R. Analysis of hypersensitivity to oleaceae pollen in an olive-free and ash-free area by commercial pollen extracts and recombinant allergens. *Eur Ann Allergy Clin Immunol*. 2011;43(3):77-80.
601. Niederberger V, Purohit A, Oster JP, Spitzauer S, Valenta R, Pauli G. The allergen profile of ash (*Fraxinus excelsior*) pollen: cross-reactivity with allergens from various plant species. *Clin Exp Allergy*. 2002;32(6):933-941.
602. Charpin D, Calleja M, Lahoz C, Pichot C, Waisel Y. Allergy to cypress pollen. *Allergy*. 2005;60(3):293-301.
603. Scala E, Alessandri C, Bernardi ML, et al. Cross-sectional survey on immunoglobulin E reactivity in 23,077 subjects using an allergenic molecule-based microarray detection system. *Clin Exp Allergy*. 2010;40(6):911-921.
604. Agea E, Bistoni O, Russano A, et al. The biology of cypress allergy. *Allergy*. 2002;57(10):959-960.
605. Aceituno E, Del Pozo V, Mínguez A, et al. Molecular cloning of major allergen from Cupressus arizonica pollen: Cup a 1. *Clin Exp Allergy*. 2000;30(12):1750-1758.
606. Swoboda I, Grote M, Verdino P, et al. Molecular characterization of polygalacturonases as grass pollen-specific marker allergens: expulsion from pollen via submicronic respirable particles. *J Immunol*. 2004;172(10):6490-6500.
607. Skypala JJ, Cecchi L, Shamji MH, Scala E, Till S. Lipid Transfer Protein allergy in the United Kingdom: Characterization and comparison with a matched Italian cohort. *Allergy*. 2019;74(7):1340-1351.
608. Kazemi-Shirazi L, Niederberger V, Linhart B, Lidholm J, Kraft D, Valenta R. Recombinant marker allergens: diagnostic gatekeepers for the treatment of allergy. *Int Arch Allergy Immunol*. 2002;127(4):259-268.
609. Scala E, Abeni D, Asero R. Disease-specific molecular profiles highlighted by radar graphic display. *Int Arch Allergy Immunol*. 2020;181:536-539.
610. Villalta D, Asero R. Analysis of the allergenic profile of patients hypersensitive to pollen pan-allergens living in two distinct areas of northern Italy. *Eur Ann Allergy Clin Immunol*. 2011;43(2):54-57.
611. Aalberse RC. Food allergens. *Environ Toxicol Pharmacol*. 1997;4(1-2):55-60.
612. Douladiris N, Savvatanos S, Roumpedaki I, Skevaki C, Mitsias D, Papadopoulos NG. A molecular diagnostic algorithm to guide pollen immunotherapy in southern Europe: towards component-resolved management of allergic diseases. *Int Arch Allergy Immunol*. 2013;162(2):163-172.
613. Asero R. Fennel, cucumber, and melon allergy successfully treated with pollen-specific injection immunotherapy. *Ann Allergy Asthma Immunol*. 2000;84(4):460-462.
614. Kinaciyan T, Jahn-Schmid B, Radakovics A, et al. Successful sublingual immunotherapy with birch pollen has limited effects on concomitant food allergy to apple and the immune response to the Bet v 1 homolog Mal d 1. *J Allergy Clin Immunol*. 2007;119(4):937-943.
615. Utsch L, Logiantara A, Wallner M, Hofer H, van Ree R, van Rijt LS. Birch pollen immunotherapy inhibits anaphylaxis to the cross-reactive apple allergen Mal d 1 in mice. *Clin Exp Allergy*. 2016;46(11):1474-1483.
616. Kleine-Tebbe J, Zuberbier T, Werfel T, et al. Is allergy immunotherapy with birch sufficient to treat patients allergic to pollen of tree species of the birch homologous group? *Allergy*. 2020;75(6):1327-1336.
617. Rodríguez R, Villalba M, Batanero E, et al. Olive pollen recombinant allergens: value in diagnosis and immunotherapy. *J Investig Allergol Clin Immunol*. 2007;17(Suppl 1):4-10.
618. Asero R, Jimeno L, Barber D. Component-resolved diagnosis of plant food allergy by SPT. *Eur Ann Allergy Clin Immunol*. 2008;40(4):115-121.

619. Scala E, Villalta D, Meneguzzi G, Brusca I, Cecchi L. Comparison of the performance of Skin Prick and ISAC Tests in the diagnosis of allergy. *Eur Ann Allergy Clin Immunol*. 2020;52(6):258-267.
620. Malandain H, Giroux S, Cano Y. The influence of carbohydrate structures present in common allergen sources on specific IgE results. *Eur Ann Allergy Clin Immunol*. 2007;39(7):216-220.
621. Demain AL, Vaishnav P. Production of recombinant proteins by microbes and higher organisms. *Biotechnol Adv*. 2009;27(3):297-306.
622. Laffer S, Vrtala S, Duchêne M, et al. IgE-binding capacity of recombinant timothy grass (*Phleum pratense*) pollen allergens. *J Allergy Clin Immunol*. 1994;94(1):88-94.
623. Nolte M, Barber D, Maloney J, et al. Timothy specific IgE levels are associated with efficacy and safety of timothy grass sublingual immunotherapy tablet. *Ann Allergy Asthma Immunol*. 2015;115(6):509-515.e502.
624. Davies JM, Berman D, Beggs PJ, et al. Global Climate Change and Pollen Aeroallergens: A Southern Hemisphere Perspective. *Immunol Allergy Clin North Am*. 2021;41(1):1-16.
625. Popescu FD. Molecular biomarkers for grass pollen immunotherapy. *World J Methodol*. 2014;4:26.
626. Bousquet PJ, Chinn S, Janson C, Kogevinas M, Burney P, Jarvis D. Geographical variation in the prevalence of positive skin tests to environmental aeroallergens in the European Community Respiratory Health Survey I. *Allergy*. 2007;62(3):301-309.
627. Salo PM, Arbes SJ Jr, Jaramillo R, et al. Prevalence of allergic sensitization in the United States: results from the National Health and Nutrition Examination Survey (NHANES) 2005-2006. *J Allergy Clin Immunol*. 2014;134(2):350-359.
628. Suphioglu C, Singh MB. Cloning, sequencing and expression in *Escherichia coli* of Pha a 1 and four isoforms of Pha a 5, the major allergens of canary grass pollen. *Clin Exp Allergy*. 1995;25(9):853-865.
629. Fischer S, Grote M, Fahlbusch B, Müller WD, Kraft D, Valenta R. Characterization of Phl p 4, a major timothy grass (*Phleum pratense*) pollen allergen. *J Allergy Clin Immunol*. 1996;98(1):189-198.
630. Devanaboyina SC, Cornelius C, Lupinek C, et al. High-resolution crystal structure and IgE recognition of the major grass pollen allergen Phl p 3. *Allergy*. 2014;69(12):1617-1628.
631. Dhammachat S, Somkid K, Piboonpocanun S, et al. Isoforms of Group 1 Allergens from a Tropical/Subtropical Para Grass (*Urochloa mutica*) Display Different Levels of IgE Reactivity and Cross-reactivity. *Eur Ann Allergy Clin Immunol*. 2019;51(4):174-185.
632. Somkid K, Aud-In S, Pinkaew B, Tantilipikorn P, Piboonpocanun S, Songnuan W. Manila grass (*Zoysia matrella*) Zoy m 1 allergen may contribute to allergic sensitization in tropical/subtropical regions due to extensive cross-reactivity with other group-1 grass pollen allergens. *Asian Pac J Allergy Immunol*. 2021.
633. Campbell BC, Gilding EK, Timbrell V, et al. Total transcriptome, proteome, and allergome of Johnson grass pollen, which is important for allergic rhinitis in subtropical regions. *J Allergy Clin Immunol*. 2015;135(1):133-142.
634. Kailaivasan TH, Timbrell VL, Solley G, et al. Biogeographical variation in specific IgE recognition of temperate and subtropical grass pollen allergens in allergic rhinitis patients. *Clin Transl Immunology*. 2020;9(2):e01103.
635. Davies JM, Mittag D, Dang TD, et al. Molecular cloning, expression and immunological characterisation of Pas n 1, the major allergen of Bahia grass *Paspalum notatum* pollen. *Mol Immunol*. 2008;46(2):286-293.
636. Timbrell VL, Riebel L, Simmonds C, et al. An immunodiagnostic assay for quantitation of specific IgE to the major pollen allergen component, Pas n 1, of the subtropical Bahia grass. *Int Arch Allergy Immunol*. 2014;165(4):219-228.
637. Bokanovic D, Aberer W, Hemmer W, et al. Determination of sIgE to rPhl p 1 is sufficient to diagnose grass pollen allergy. *Allergy*. 2013;68(11):1403-1409.
638. Cipriani F, Tripodi S, Panetta V, et al. Early molecular biomarkers predicting the evolution of allergic rhinitis and its comorbidities: A longitudinal multicenter study of a patient cohort. *Pediatr Allergy Immunol*. 2019;30(3):325-334.
639. Gadermaier E, James LK, Shamji MH, et al. Epitope specificity determines cross-protection of a SIT-induced IgG4 antibody. *Allergy*. 2016;71(1):36-46.
640. Westman M, Åberg K, Apostolovic D, et al. Sensitization to grass pollen allergen molecules in a birth cohort-natural Phl p 4 as an early indicator of grass pollen allergy. *J Allergy Clin Immunol*. 2020;145(4):1174-1181.e1176.
641. Hew M, Lee J, Varese N, et al. Epidemic thunderstorm asthma susceptibility from sensitization to ryegrass (*Lolium perenne*) pollen and major allergen Lol p 5. *Allergy*. 2020;75:2369-2372.
642. Thien F, Davies JM, Hew M, Douglass JA, O'Hehir RE. Thunderstorm asthma: an overview of mechanisms and management strategies. *Expert Rev Clin Immunol*. 2020;16(10):1005-1017.
643. Sutherland MF, Portelli EL, Collins AL, Rahman MA, CF MD. Patients with thunderstorm asthma or severe asthma in Melbourne: a comparison. *Med J Aust*. 2017;207:434-435.
644. Thien F, Beggs PJ, Csutoros D, et al. The Melbourne epidemic thunderstorm asthma event 2016: an investigation of environmental triggers, effect on health services, and patient risk factors. *Lancet Planet Health*. 2018;2(6):e255-e263.
645. Marks GB, Colquhoun JR, Girgis ST, et al. Thunderstorm outflows preceding epidemics of asthma during spring and summer. *Thorax*. 2001;56(6):468-471.
646. Davies JM, Thien F, Hew M. Thunderstorm asthma: controlling (deadly) grass pollen allergy. *BMJ*. 2018;360:k432.
647. Shamji MH, Kappen J, Abubakar-Waziri H, et al. Nasal allergen-neutralizing IgG(4) antibodies block IgE-mediated responses: Novel biomarker of subcutaneous grass pollen immunotherapy. *J Allergy Clin Immunol*. 2019;143(3):1067-1076.
648. Castelli S, Arasi S, Pawankar R, Matricardi PM. Collection of nasal secretions and tears and their use in allergology. *Curr Opin Allergy Clin Immunol*. 2018;18(1):1-9.
649. Castelli S, Arasi S, Tripodi S, et al. IgE antibody repertoire in nasal secretions of children and adults with seasonal allergic rhinitis: A molecular analysis. *Pediatr Allergy Immunol*. 2020;31(3):273-280.
650. Schmid JM, Würtzen PA, Dahl R, Hoffmann HJ. Pretreatment IgE sensitization patterns determine the molecular profile of the IgG4 response during up dosing of subcutaneous immunotherapy with timothy grass pollen extract. *J Allergy Clin Immunol*. 2016;137(2):562-570.
651. Storkey J, Stratonovitch P, Chapman DS, Vidotto F, Semenov MA. A process-based approach to predicting the effect of climate change on the distribution of an invasive allergenic plant in Europe. *PLoS One*. 2014;9(2):e88156.
652. Stemeseder T, Hemmer W, Hawranek T, Gadermaier G. Marker allergens of weed pollen - basic considerations and diagnostic benefits in the clinical routine: Part 16 of the Series Molecular Allergology. *Allergo J Int*. 2014;23(8):274-280.
653. Anderegg WRL, Abatzoglou JT, Anderegg LDL, Bielory L, Kinney PL, Ziska L. Anthropogenic climate change is worsening North American pollen seasons. *Proc Natl Acad Sci U S A*. 2021;118(7).
654. Lake IR, Jones NR, Agnew M, et al. Climate Change and Future Pollen Allergy in Europe. *Environ Health Perspect*. 2017;125(3):385-391.
655. Fu W, Gao Z, Gao L, et al. Identification of a 62-kDa major allergen from *Artemisia* pollen as a putative galactose oxidase. *Allergy*. 2018;73(5):1041-1052.
656. Ariano R, Canonica GW, Passalacqua G. Possible role of climate changes in variations in pollen seasons and allergic sensitizations during 27 years. *Ann Allergy Asthma Immunol*. 2010;104(3):215-222.
657. Ghiani A, Aina R, Asero R, Bellotto E, Citterio S. Ragweed pollen collected along high-traffic roads shows a higher allergenicity than pollen sampled in vegetated areas. *Allergy*. 2012;67(7):887-894.

- 658a. Bouley J, Groeme R, Le Mignon M, et al. Identification of the cysteine protease Amb a 11 as a novel major allergen from short ragweed. *J Allergy Clin Immunol*. 2015;136(4):1055-1064.
- 658b. Arbes SJ Jr, Gergen PJ, Elliott L, et al. Prevalences of positive skin test responses to 10 common allergens in the US population: results from the third National Health and Nutrition Examination Survey. *J Allergy Clin Immunol*. 2005;116(2):377-383.
- 658c. Burbach GJ, Heinzerling LM, Edenharter G, et al. GA(2)LEN skin test study II: clinical relevance Molecular Allergology User's Guide 2.0 212 of inhalant allergen sensitisations in Europe. *Allergy*. 2009;64(10):1507-1515.
- 659a. Forkel S, Beutner C, Heetfeld A, et al. Allergic Rhinitis to Weed Pollen in Germany: Dominance by Plantain, Rising Prevalence, and Polysensitization Rates over 20 Years. *Int Arch Allergy Immunol*. 2020;181(2):128-135.
- 659b. Ruëff F, Przybilla B, Walker A, et al. Sensitisation to common ragweed in southern Bavaria: clinical and geographical risk factors in atopic patients. *Int Arch Allergy Immunol*. 2012;159(1):65-74.
660. Minami T, Fukutomi Y, Inada R, et al. Regional differences in the prevalence of sensitization to environmental allergens: Analysis on IgE antibody testing conducted at major clinical testing laboratories throughout Japan from 2002 to 2011. *Allergol Int*. 2019;68(4):440-449.
661. Bass DJ, Delpech V, Beard J, Bass P, Walls RS. Late summer and fall (March-May) pollen allergy and respiratory disease in Northern New South Wales. *Australia Ann Allergy Asthma Immunol*. 2000;85(5):374-381.
662. Bordas-Le Floch V, Le Mignon M, Bouley J, et al. Identification of Novel Short Ragweed Pollen Allergens Using Combined Transcriptomic and Immunoproteomic Approaches. *PLoS One*. 2015;10(8):e0136258.
663. Wang W, Zhang XH, Zhu L, Liu YX. Investigation of Allergic Sensitization Pattern in 4,203 Children in Northern China. *Int Arch Allergy Immunol*. 2021;182(5):455-458.
664. Hao GD, Zheng YW, Gjesing B, et al. Prevalence of sensitization to weed pollens of *Humulus scandens*, *Artemisia vulgaris*, and *Ambrosia artemisiifolia* in northern China. *J Zhejiang Univ Sci B*. 2013;14(3):240-246.
665. Sung M, Kim SW, Kim JH, Lim DH. Regional Difference of Causative Pollen in Children with Allergic Rhinitis. *J Korean Med Sci*. 2017;32(6):926-932.
666. Stemeseder T, Klinglmayr E, Moser S, et al. Cross-sectional study on allergic sensitization of Austrian adolescents using molecule-based IgE profiling. *Allergy*. 2017;72(5):754-763.
667. Barber D, Diaz-Perales A, Villalba M, Chivato T. Challenges for allergy diagnosis in regions with complex pollen exposures. *Curr Allergy Asthma Rep*. 2015;15(2):496.
668. Pablos I, Egger M, Vejvar E, et al. Similar Allergenecity to Different *Artemisia* Species Is a Consequence of Highly Cross-Reactive Art v 1-Like Molecules. *Medicina (Kaunas)*. 2019;55(8).
669. Gao ZS, Yang ZW, Wu SD, et al. Peach allergy in China: a dominant role for mugwort pollen LTP as primary sensitizier. *J Allergy Clin Immunol*. 2013;Jan;131(131):224-136.
670. Zhao L, Fu W, Gao B, et al. Variation in IgE binding potencies of seven *Artemisia* species depending on content of major allergens. *Clin Transl Allergy*. 2020;10(1):50.
671. Atis S, Tutluoglu B, Sahin K, Yaman M, Kucukusta AR, Oktay I. Sensitization to sunflower pollen and lung functions in sunflower processing workers. *Allergy*. 2002;57(1):35-39.
672. Ghosh N, Sircar G, Saha B, Pandey N, Gupta Bhattacharya S. Search for Allergens from the Pollen Proteome of Sunflower (*Helianthus annuus* L.): A Major Sensitizer for Respiratory Allergy Patients. *PLoS One*. 2015;10(9):e0138992.
673. Gruber P, Gadermaier G, Bauer R, et al. Role of the polypeptide backbone and post-translational modifications in cross-reactivity of Art v 1, the major mugwort pollen allergen. *Biol Chem*. 2009;390(5-6):445-451.
674. Kumar S, Khandpu S, Rao DN, Wahaab S, Khanna N. Immunological response to *Parthenium hysterophorus* in Indian Patients with *Parthenium* sensitive atopic dermatitis. *Immunol Invest*. 2012;41(1):75-86.
675. Pablos I, Eichhorn S, Briza P, et al. Proteomic profiling of the weed feverfew, a neglected pollen allergen source. *Sci Rep*. 2017;7(1):6049.
676. Liccardi G, Baldi G, Berra A, et al. Allergy in urban elderly population living in Campania region (Southern Italy). A multicenter study. *Eur Ann Allergy Clin Immunol*. 2016;48(4):156-160.
677. Liccardi G, Calzetta L, Apicella G, et al. Allergy in adolescent population (14-18 years) living in Campania region (Southern Italy). A multicenter study. *Eur Ann Allergy Clin Immunol*. 2019;51(1).
678. Gadermaier G, Eichhorn S, Vejvar E, et al. *Plantago lanceolata*: an important trigger of summer pollinosis with limited IgE cross-reactivity. *J Allergy Clin Immunol*. 2014;134(2):472-475.
679. Stemeseder T, Metz-Favre C, de Blay F, Pauli G, Gadermaier G. Do *Plantago lanceolata* Skin Prick Test-Positive Patients Display IgE to Genuine *Plantain* Pollen Allergens? Investigation of Pollen Allergic Patients from the North-East of France. *Int Arch Allergy Immunol*. 2018;177(2):97-106.
680. Gadermaier G, Hauser M, Ferreira F. Allergens of weed pollen: an overview on recombinant and natural molecules. *Methods*. 2014;66(1):55-66.
681. Villalba M, Barderas R, Mas S, Colas C, Batanero E, Rodriguez R. *Amaranthaceae* pollens: review of an emerging allergy in the mediterranean area. *J Investig Allergol Clin Immunol*. 2014;24(6):371-381. quiz 372 p preceding 382.
682. Assarehzadegan MA, Amini A, Sankian M, Tehrani M, Jabbari F, Varasteh A. Sal k 4, a new allergen of *Salsola kali*, is profilin: a predictive value of conserved conformational regions in cross-reactivity with other plant-derived profilins. *Biosci Biotechnol Biochem*. 2010;74(7):1441-1446.
683. Assarehzadegan MA, Sankian M, Jabbari F, Tehrani M, Falak R, Varasteh A. Identification of methionine synthase (Sal k 3), as a novel allergen of *Salsola kali* pollen. *Mol Biol Rep*. 2011;38(1):65-73.
684. Castro L, Mas S, Barderas R, et al. Sal k 5, a member of the widespread Ole e 1-like protein family, is a new allergen of Russian thistle (*Salsola kali*) pollen. *Int Arch Allergy Immunol*. 2014;163(2):142-153.
685. Mas S, Oeo-Santos C, Cuesta-Herranz J, et al. A relevant IgE-reactive 28kDa protein identified from *Salsola kali* pollen extract by proteomics is a natural degradation product of an integral 47kDa polygalacturonase. *Biochim Biophys Acta Proteins Proteomics*. 2017;1865(8):1067-1076.
686. Asero R, Bellotto E, Ghiani A, Aina R, Villalta D, Citterio S. Concomitant sensitization to ragweed and mugwort pollen: who is who in clinical allergy? *Ann Allergy Asthma Immunol*. 2014;113(3):307-313.
687. Jahn-Schmid B, Hauser M, Wopfner N, et al. Humoral and cellular cross-reactivity between Amb a 1, the major ragweed pollen allergen, and its mugwort homolog Art v 6. *J Immunol*. 2012;188(3):1559-1567.
688. Pablos I, Eichhorn S, Machado Y, et al. Distinct epitope structures of defensin-like proteins linked to proline-rich regions give rise to differences in their allergenic activity. *Allergy*. 2018;73(2):431-441.
689. Wangorsch A, Lidholm J, Mattsson LA, et al. Identification of a defensin as novel allergen in celery root: Api g 7 as a missing link in the diagnosis of celery allergy? *Allergy*. 2021.
690. Egger M, Mutschlechner S, Wopfner N, Gadermaier G, Briza P, Ferreira F. Pollen-food syndromes associated with weed pollinosis: an update from the molecular point of view. *Allergy*. 2006;61(4):461-476.

691. Tordesillas L, Sirvent S, Diaz-Perales A, et al. Plant lipid transfer protein allergens: no cross-reactivity between those from foods and olive and Parietaria pollen. *Int Arch Allergy Immunol*. 2011;156(3):291-296.
692. Gao Z, Fu WY, Sun Y, et al. Artemisia pollen allergy in China: Component-resolved diagnosis reveals allergic asthma patients have significant multiple allergen sensitization. *Allergy*. 2019;74(2):284-293.
693. Rodriguez Del Rio P, Diaz-Perales A, Sanchez-Garcia S, et al. Profilin, a Change in the Paradigm. *J Investig Allergol Clin Immunol*. 2018;28(1):1-12.
694. Asero R, Monsalve R, Barber D. Profilin sensitization detected in the office by skin prick test: a study of prevalence and clinical relevance of profilin as a plant food allergen. *Clin Exp Allergy*. 2008;38(6):1033-1037.
695. Kratzer B, Kohler C, Hofer S, et al. Prevention of allergy by virus-like nanoparticles (VNP) delivering shielded versions of major allergens in a humanized murine allergy model. *Allergy*. 2019;74(2):246-260.
696. Di Muzio M, Wildner S, Huber S, et al. Hydrogen/deuterium exchange memory NMR reveals structural epitopes involved in IgE cross-reactivity of allergenic lipid transfer proteins. *J Biol Chem*. 2020;295(51):17398-17410.
697. de Blay F, Heymann PW, Chapman MD, Platts-Mills TA. Airborne dust mite allergens: comparison of group II allergens with group I mite allergen and cat-allergen Fel d 1. *J Allergy Clin Immunol*. 1991;88(6):919-926.
698. Tovey ER, Chapman MD, Platts-Mills TA. Mite faeces are a major source of house dust allergens. *Nature*. 1981;289(5798):592-593.
699. Tovey ER, Chapman MD, Wells CW, Platts-Mills TA. The distribution of dust mite allergen in the houses of patients with asthma. *Am Rev Respir Dis*. 1981;124(5):630-635.
700. Darquenne C. Aerosol deposition in health and disease. *J Aerosol Med Pulm Drug Deliv*. 2012;25(3):140-147.
701. Caraballo L, Puerta L, Martínez B, Moreno L. Identification of allergens from the mite *Blomia tropicalis*. *Clin Exp Allergy*. 1994;24(11):1056-1060.
702. Arruda LK, Fernandez-Caldas E, Naspitz CK, Montealegre F, Vailes LD, Chapman MD. Identification of *Blomia tropicalis* allergen Blo t 5 by cDNA cloning. *Int Arch Allergy Immunol*. 1995;107(1-3):456-457.
703. Heymann PW, Chapman MD, Aalberse RC, Fox JW, Platts-Mills TA. Antigenic and structural analysis of group II allergens (Der f II and Der p II) from house dust mites (*Dermatophagoides* spp). *J Allergy Clin Immunol*. 1989;83(6):1055-1067.
704. Derewenda U, Li J, Derewenda Z, et al. The crystal structure of a major dust mite allergen Der p 2, and its biological implications. *J Mol Biol*. 2002;318(1):189-197.
705. de Halleux S, Stura E, VanderElst L, Carlier V, Jacquemin M, Saint-Remy JM. Three-dimensional structure and IgE-binding properties of mature fully active Der p 1, a clinically relevant major allergen. *J Allergy Clin Immunol*. 2006;117(3):571-576.
706. Mueller GA, Edwards LL, Aloor JJ, et al. The structure of the dust mite allergen Der p 7 reveals similarities to innate immune proteins. *J Allergy Clin Immunol*. 2010;125(4):909-917.e904.
707. Mueller GA, Gosavi RA, Krahn JM, et al. Der p 5 crystal structure provides insight into the group 5 dust mite allergens. *J Biol Chem*. 2010;285(33):25394-25401.
708. Mueller GA, Pedersen LC, Glesner J, et al. Analysis of glutathione S-transferase allergen cross-reactivity in a North American population: Relevance for molecular diagnosis. *J Allergy Clin Immunol*. 2015;136(5):1369-1377.
709. Waldron R, McGowan J, Gordon N, McCarthy C, Mitchell EB, Fitzpatrick DA. Proteome and allergenome of the European house dust mite *Dermatophagoides pteronyssinus*. *PLoS One*. 2019;14(5):e0216171.
710. Sporik R, Holgate ST, Platts-Mills TA, Cogswell JJ. Exposure to house-dust mite allergen (Der p I) and the development of asthma in childhood. A prospective study. *N Engl J Med*. 1990;323(8):502-507.
711. Resch Y, Michel S, Kabesch M, Lupinek C, Valenta R, Vrtala S. Different IgE recognition of mite allergen components in asthmatic and nonasthmatic children. *J Allergy Clin Immunol*. 2015;136(4):1083-1091.
712. Muddaluru V, Valenta R, Vrtala S, et al. Comparison of house dust mite sensitization profiles in allergic adults from Canada, Europe, South Africa and USA. *Allergy*. 2021;76(7):2177-2188.
713. Batard T, Baron-Bodo V, Martelet A, et al. Patterns of IgE sensitization in house dust mite-allergic patients: implications for allergen immunotherapy. *Allergy*. 2016;71(2):220-229.
714. Pinheiro CS, Silva ES, de Andrade Belitardo EMM, et al. En route to personalized medicine: uncovering distinct IgE reactivity pattern to house dust mite components in Brazilian and Austrian allergic patients. *Clin Transl Allergy*. 2021;11:e12004.
715. Carvalho Kdos A, de Melo-Neto OP, Magalhães FB, et al. *Blomia tropicalis* Blo t 5 and Blo t 21 recombinant allergens might confer higher specificity to serodiagnostic assays than whole mite extract. *BMC Immunol*. 2013;14:11.
716. Platts-Mills TA, Tovey ER, Mitchell EB, Moszoro H, Nock P, Wilkins SR. Reduction of bronchial hyperreactivity during prolonged allergen avoidance. *Lancet*. 1982;2(8300):675-678.
717. Huang HJ, Resch-Marat Y, Casset A, et al. IgE recognition of the house dust mite allergen Der p 37 is associated with asthma. *J Allergy Clin Immunol*. 2022;149(3):1031-1043.
718. Abu Khweek A, Kim E, Joldrichsen MR, Amer AO, Boyaka PN. Insights Into Mucosal Innate Immune Responses in House Dust Mite-Mediated Allergic Asthma. *Front Immunol*. 2020;11:534501.
719. Wan H, Winton HL, Soeller C, et al. Der p 1 facilitates transepithelial allergen delivery by disruption of tight junctions. *J Clin Invest*. 1999;104(1):123-133.
720. Zhang J, Chen J, Robinson C. Cellular and Molecular Events in the Airway Epithelium Defining the Interaction Between House Dust Mite Group 1 Allergens and Innate Defences. *Int J Mol Sci*. 2018;19(11).
721. Schulz O, Sewell HF, Shakib F. Proteolytic cleavage of CD25, the alpha subunit of the human T cell interleukin 2 receptor, by Der p 1, a major mite allergen with cysteine protease activity. *J Exp Med*. 1998;187(2):271-275.
722. Chevigné A, Jacquet A. Emerging roles of the protease allergen Der p 1 in house dust mite-induced airway inflammation. *J Allergy Clin Immunol*. 2018;142(2):398-400.
723. Hewitt CR, Brown AP, Hart BJ, Pritchard DI. A major house dust mite allergen disrupts the immunoglobulin E network by selectively cleaving CD23: innate protection by antiproteases. *J Exp Med*. 1995;182(5):1537-1544.
724. Serhan N, Basso L, Sibilano R, et al. House dust mites activate nociceptor-mast cell clusters to drive type 2 skin inflammation. *Nat Immunol*. 2019;20(11):1435-1443.
725. Hammad H, Chieppa M, Perros F, Willart MA, Germain RN, Lambrecht BN. House dust mite allergen induces asthma via Toll-like receptor 4 triggering of airway structural cells. *Nat Med*. 2009;15(4):410-416.
726. Pulsawat P, Theeraapisakkun M, Nony E, et al. Characterization of the house dust mite allergen Der p 21 produced in *Pichia pastoris*. *Protein Expr Purif*. 2014;101:8-13.
727. Soongrung T, Mongkorntanyatip K, Peepim T, et al. The *Blomia tropicalis* allergen Blo t 7 stimulates innate immune signalling pathways through TLR2. *Clin Exp Allergy*. 2018;48(4):464-474.
728. Pulsawat P, Soongrung T, Satitsuksanoa P, et al. The house dust mite allergen Der p 5 binds lipid ligands and stimulates airway epithelial cells through a TLR2-dependent pathway. *Clin Exp Allergy*. 2019;49(3):378-390.

729. Zakzuk J, Benedetti I, Fernández-Caldas E, Caraballo L. The influence of chitin on the immune response to the house dust mite allergen Blo T 12. *Int Arch Allergy Immunol.* 2014;163(2):119-129.
730. Gour N, Lajoie S, Smole U, et al. Dysregulated invertebrate tropomyosin-dectin-1 interaction confers susceptibility to allergic diseases. *Sci Immunol.* 2018;3(20).
731. Kim G, Hong M, Kashif A, et al. Der f 38 Is a Novel TLR4-Binding Allergen Related to Allergy Pathogenesis from Dermatophagoides farinae. *Int J Mol Sci.* 2021;22(16).
732. Casset A, Mari A, Purohit A, et al. Varying allergen composition and content affects the *in vivo* allergenic activity of commercial Dermatophagoides pteronyssinus extracts. *Int Arch Allergy Immunol.* 2012;159(3):253-262.
733. Huang HJ, Resch-Marat Y, Rodriguez-Dominguez A, et al. Underestimation of house dust mite-specific IgE with extract-based ImmunoCAPs compared with molecular ImmunoCAPs. *J Allergy Clin Immunol.* 2018;142(5):1656-1659.e1659.
734. Soto-Quiros M, Avila L, Platts-Mills TA, et al. High titers of IgE antibody to dust mite allergen and risk for wheezing among asthmatic children infected with rhinovirus. *J Allergy Clin Immunol.* 2012;129(6):1499-1505.e1495.
735. Mourao EMM, Rosario NA. Conjunctival Provocation Test With Blomia tropicalis. *Front Allergy.* 2021;2:673462.
736. Zakzuk J, Lozano A, Caraballo L. Allergological Importance of Invertebrate Glutathione Transferases in Tropical Environments. *Front Allergy.* 2021;2:695262.
737. Platts-Mills TA, Thomas WR, Aalberse RC, Vervloet D, Chapman MD. Dust mite allergens and asthma: report of a second international workshop. *J Allergy Clin Immunol.* 1992;89:1046-1060.
738. Kerrebijn K. Endogenous factors in childhood CNSLD. In: NGM O, van der Lende R, eds. *Bronchitis III, The Netherlands: Royal Vangorcum Assen*; 1970:38-48.
739. Charpin D, Kleisbauer JP, Lanteaume A, et al. Asthma and allergy to house-dust mites in populations living in high altitudes. *Chest.* 1988;93(4):758-761.
740. Piacentini GL, Del Giudice MJ, Bodini A, et al. Exhaled NO reduced on allergen avoidance. *Allergy.* 2001;56(3):251-252.
741. Glesner J, Vailes LD, Schlachter C, et al. Antigenic Determinants of Der p 1: Specificity and Cross-Reactivity Associated with IgE Antibody Recognition. *J Immunol.* 2017;198(3):1334-1344.
742. Smith AM, Benjamin DC, Hozic N, et al. The molecular basis of antigenic cross-reactivity between the group 2 mite allergens. *J Allergy Clin Immunol.* 2001;107(6):977-984.
743. Cochran DG Cockroaches their biology, distribution and control. In: Geneva, World Health Organization (document number: WHO/CDS/CPC/WHOPES/99.3); 1999.
744. Sporik R, Squillace SP, Ingram JM, Rakes G, Honsinger RW, Platts-Mills TA. Mite, cat, and cockroach exposure, allergen sensitization, and asthma in children: a case-control study of three schools. *Thorax.* 1999;54(8):675-680.
745. Pomés A, Melén E, Vailes LD, Retief JD, Arruda LK, Chapman MD. Novel allergen structures with tandem amino acid repeats derived from German and American cockroach. *J Biol Chem.* 1998;273(46):30801-30807.
746. Satinover SM, Reefer AJ, Pomés A, Chapman MD, Platts-Mills TA, Woodfolk JA. Specific IgE and IgG antibody-binding patterns to recombinant cockroach allergens. *J Allergy Clin Immunol.* 2005;115(4):803-809.
747. Gustchina A, Li M, Wünschmann S, Chapman MD, Pomés A, Wlodawer A. Crystal structure of cockroach allergen Bla g 2, an unusual zinc binding aspartic protease with a novel mode of self-inhibition. *J Mol Biol.* 2005;348(2):433-444.
748. Glesner J, Wünschmann S, Li M, et al. Mechanisms of allergen-antibody interaction of cockroach allergen Bla g 2 with monoclonal antibodies that inhibit IgE antibody binding. *PLoS One.* 2011;6(7):e22223.
749. Li M, Gustchina A, Alexandratos J, et al. Crystal structure of a dimerized cockroach allergen Bla g 2 complexed with a monoclonal antibody. *J Biol Chem.* 2008;283(33):22806-22814.
750. Do DC, Yang S, Yao X, Hamilton RG, Schroeder JT, Gao P. N-glycan in cockroach allergen regulates human basophil function. *Immun Inflamm Dis.* 2017;5(4):386-399.
751. Jeng KC, Liu MT, Wu CH, Wong DW, Lan JL. American cockroach Cr-PI allergen induces lymphocyte proliferation and cytokine production in atopic patients. *Clin Exp Allergy.* 1996;26(3):349-356.
752. Hindley J, Wünschmann S, Satinover SM, et al. Bla g 6: a troponin C allergen from *Blattella germanica* with IgE binding calcium dependence. *J Allergy Clin Immunol.* 2006;117(6):1389-1395.
753. Sookrung N, Chaicumpa W, Tungtrongchitr A, et al. *Periplaneta americana* arginine kinase as a major cockroach allergen among Thai patients with major cockroach allergies. *Environ Health Perspect.* 2006;114(6):875-880.
754. Glesner J, Filep S, Vailes LD, et al. Allergen content in German cockroach extracts and sensitization profiles to a new expanded set of cockroach allergens determine *in vitro* extract potency for IgE reactivity. *J Allergy Clin Immunol.* 2019;143(4):1474-1481.e1478.
755. Binder M, Mahler V, Hayek B, et al. Molecular and immunological characterization of arginine kinase from the Indianmeal moth, *Plodia interpunctella*, a novel cross-reactive invertebrate pan-allergen. *J Immunol.* 2001;167(9):5470-5477.
756. Sudha VT, Arora N, Gaur SN, Pasha S, Singh BP. Identification of a serine protease as a major allergen (Per a 10) of *Periplaneta americana*. *Allergy.* 2008;63(6):768-776.
757. Jeong KY, Kim CR, Park J, Han IS, Park JW, Yong TS. Identification of novel allergenic components from German cockroach fecal extract by a proteomic approach. *Int Arch Allergy Immunol.* 2013;161(4):315-324.
758. Fang Y, Long C, Bai X, et al. Two new types of allergens from the cockroach, *Periplaneta americana*. *Allergy.* 2015;70(12):1674-1678.
759. Pomés A, Schulten V, Glesner J, et al. IgE and T Cell reactivity to a comprehensive panel of cockroach allergens in relation to disease. *Front Immunol.* 2020;11:621700.
760. Bernton HS, Brown H. Insect allergy - Preliminary studies of the cockroach. *J Allergy.* 1964;35:506-513.
761. Kang B, Vellody D, Homburger H, Yunginger JW. Cockroach cause of allergic asthma. Its specificity and immunologic profile. *J Allergy Clin Immunol.* 1979;63(2):80-86.
762. Pomés A, Glesner J, Calatroni A, et al. Cockroach allergen component analysis of children with or without asthma and rhinitis in an inner-city birth cohort. *J Allergy Clin Immunol.* 2019;144(4):935-944.
763. Lee MF, Song PP, Hwang GY, Lin SJ, Chen YH. Sensitization to Per a 2 of the American cockroach correlates with more clinical severity among airway allergic patients in Taiwan. *Ann Allergy Asthma Immunol.* 2012;108(4):243-248.
764. Hulett AC, Dockhorn RJ. House dust, mite (*D. farinae*) and cockroach allergy in a midwestern population. *Ann Allergy.* 1979;42(3):160-165.
765. Call RS, Smith TF, Morris E, Chapman MD, Platts-Mills TA. Risk factors for asthma in inner city children. *J Pediatr.* 1992;121(6):862-866.
766. Gelber LE, Seltzer LH, Bouzoukis JK, Pollart SM, Chapman MD, Platts-Mills TA. Sensitization and exposure to indoor allergens as risk factors for asthma among patients presenting to hospital. *Am Rev Respir Dis.* 1993;147(3):573-578.
767. Gruchalla RS, Pongracic J, Plaut M, et al. Inner City Asthma Study: relationships among sensitivity, allergen exposure, and asthma morbidity. *J Allergy Clin Immunol.* 2005;115(3):478-485.
768. Rosenstreich DL, Eggleston P, Kattan M, et al. The role of cockroach allergy and exposure to cockroach allergen in causing

- morbidity among inner-city children with asthma. *N Engl J Med*. 1997;336(19):1356-1363.
769. Liao C, Hu H, Huang Z, et al. Shrimp and cockroach co-sensitization in Southern China: Association with moth sensitization. *Allergy Asthma Proc*. 2020;41(3):e54-e60.
770. Acevedo N, Mohr J, Zakzuk J, et al. Proteomic and immunochemical characterization of glutathione transferase as a new allergen of the nematode *Ascaris lumbricoides*. *PLoS One*. 2013;8(11):e78353.
771. Westritschnig K, Sibanda E, Thomas W, et al. Analysis of the sensitization profile towards allergens in central Africa. *Clin Exp Allergy*. 2003;33(1):22-27.
772. Barbosa MC, Santos AB, Ferriani VP, Pomés A, Chapman MD, Arruda LK. Efficacy of recombinant allergens for diagnosis of cockroach allergy in patients with asthma and/or rhinitis. *Int Arch Allergy Immunol*. 2013;161(3):213-219.
773. Acevedo N, Erler A, Briza P, Puccio F, Ferreira F, Caraballo L. Allergenicity of *Ascaris lumbricoides* tropomyosin and IgE sensitization among asthmatic patients in a tropical environment. *Int Arch Allergy Immunol*. 2011;154(3):195-206.
774. Pomés A, Arruda LK. Investigating cockroach allergens: aiming to improve diagnosis and treatment of cockroach allergic patients. *Methods*. 2014;66(1):75-85.
775. Ahumada V, García E, Dennis R, et al. IgE responses to *Ascaris* and mite tropomyosins are risk factors for asthma. *Clin Exp Allergy*. 2015;45(7):1189-1200.
776. Birrueta G, Frazier A, Pomés A, et al. Variability in German Cockroach Extract Composition Greatly Impacts T Cell Potency in Cockroach-Allergic Donors. *Front Immunol*. 2019;10:313.
777. Mindaye ST, David NA, Zarkesh Esfahani SA, et al. Measurement of German cockroach allergens and their isoforms in allergen extracts with mass spectrometry. *Clin Exp Allergy*. 2020;50(6):741-751.
778. Chuang JG, Su SN, Chiang BL, Lee HJ, Chow LP. Proteome mining for novel IgE-binding proteins from the German cockroach (*Blattella germanica*) and allergen profiling of patients. *Proteomics*. 2010;10(21):3854-3867.
779. Finn PW, Boudreau JO, He H, et al. Children at risk for asthma: home allergen levels, lymphocyte proliferation, and wheeze. *J Allergy Clin Immunol*. 2000;105(5):933-942.
780. Pomés A, Schal C. *Cockroach and Other Inhalant Insect Allergens, in Allergens and Allergen Immunotherapy for Allergic Diseases, Subcutaneous, Sublingual and Oral*, L.D. Lockey R, Editor. CRC Press/Taylor & Francis Group; 2020.
781. Srivastava D, Gaur SN, Arora N, Singh BP. Clinico-immunological changes post-immunotherapy with *Periplaneta americana*. *Eur J Clin Invest*. 2011;41(8):879-888.
782. Meechan P, Tungtrongchitr A, Chairsi U, et al. Intranasal, liposome-adjuvanted cockroach allergy vaccines made of refined major allergen and whole-body extract of *Periplaneta americana*. *Int Arch Allergy Immunol*. 2013;161(4):351-362.
783. Konradsen JR, Fujisawa T, van Hage M, et al. Allergy to furry animals: New insights, diagnostic approaches, and challenges. *J Allergy Clin Immunol*. 2015;135(3):616-625.
784. Polovic N, Wadén K, Binmyr J, et al. Dog saliva - an important source of dog allergens. *Allergy*. 2013;68(5):585-592.
785. Zahradnik E, Raulf M. Respiratory Allergens from Furred Mammals: Environmental and Occupational Exposure. *Vet Sci*. 2017;4(3).
786. Almqvist C, Wickman M, Perfetti L, et al. Worsening of asthma in children allergic to cats, after indirect exposure to cat at school. *Am J Respir Crit Care Med*. 2001;163(3 Pt 1):694-698.
787. Ritz BR, Hoelscher B, Frye C, Meyer I, Heinrich J. Allergic sensitization owing to 'second-hand' cat exposure in schools. *Allergy*. 2002;57(4):357-361.
788. Pecquet C. New pets and allergies. *Eur J Dermatol*. 2012;22(1):14-22.
789. Maeda Y, Akiyama K. Anaphylaxis after a cat bite. *Allergol Int*. 2012;61:511-512.
790. Guida G, Nebiolo F, Heffler E, Bergia R, Rolla G. Anaphylaxis after a horse bite. *Allergy*. 2005;60(8):1088-1089.
791. Torres JA, Sastre J, Vivanco F, Sanz Maroto A, de Las HM, Pastor-Vargas C. Clinical Characteristics of Patients Sensitized to Siberian Hamster. *J Investig Allergol Clin Immunol*. 2016;26(2):113-115.
792. Butt A, Rashid D, Lockey RF. Do hypoallergenic cats and dogs exist? *Ann Allergy Asthma Immunol*. 2012;108(2):74-76.
793. Zahradnik E, Sander I, Brüning T, Raulf M. Allergen Levels in the Hair of Different Cattle Breeds. *Int Arch Allergy Immunol*. 2015;167(1):9-15.
794. Zahradnik E, Janssen-Weets B, Sander I, et al. Lower allergen levels in hypoallergenic Curly Horses? A comparison among breeds by measurements of horse allergens in hair and air samples. *PLoS One*. 2018;13(12):e0207871.
795. Hilger C, Kohnen M, Grigioni F, Lehnert C, Hentges F. Allergic cross-reactions between cat and pig serum albumin. Study at the protein and DNA levels. *Allergy*. 1997;52(2):179-187.
796. Martini M, Swiontek K, Antonicelli L, et al. Lysozyme, a new allergen in donkey's milk. *Clin Exp Allergy*. 2018;48(11):1521-1523.
797. Khurana T, Newman-Lindsay S, Young PR, Slater JE. The NPC2 protein: A novel dog allergen. *Ann Allergy Asthma Immunol*. 2016;116(5):440-446.e442.
798. Schmitz R, Ellert U, Kalcklösch M, Dahm S, Thamm M. Patterns of sensitization to inhalant and food allergens - findings from the German Health Interview and Examination Survey for Children and Adolescents. *Int Arch Allergy Immunol*. 2013;162(3):263-270.
799. Melén E, Bergström A, Kull I, et al. Male sex is strongly associated with IgE-sensitization to airborne but not food allergens: results up to age 24 years from the BAMSE birth cohort. *Clin Transl Allergy*. 2020;10:15.
800. Warm K, Lindberg A, Lundbäck B, Rönmark E. Increase in sensitization to common airborne allergens among adults - two population-based studies 15 years apart. *Allergy Asthma Clin Immunol*. 2013;9(1):20.
801. Heinzerling LM, Burbach GJ, Edenharter G, et al. GA(2)LEN skin test study I: GA(2)LEN harmonization of skin prick testing: novel sensitization patterns for inhalant allergens in Europe. *Allergy*. 2009;64(10):1498-1506.
802. Dávila I, Domínguez-Ortega J, Navarro-Pulido A, et al. Consensus document on dog and cat allergy. *Allergy*. 2018;73(6):1206-1222.
803. Schoos AM, Nwaru BI, Borres MP. Component-resolved diagnostics in pet allergy: Current perspectives and future directions. *J Allergy Clin Immunol*. 2021;147(4):1164-1173.
804. Grönlund H, Adéyoyin J, Reininger R, et al. Higher immunoglobulin E antibody levels to recombinant Fel d 1 in cat-allergic children with asthma compared with rhinoconjunctivitis. *Clin Exp Allergy*. 2008;38(8):1275-1281.
805. Suzuki S, Nwaru BI, Ekerljung L, et al. Characterization of sensitization to furry animal allergen components in an adult population. *Clin Exp Allergy*. 2019;49(4):495-505.
806. Bjerg A, Winberg A, Berthold M, Mattsson L, Borres MP, Rönmark E. A population-based study of animal component sensitization, asthma, and rhinitis in schoolchildren. *Pediatr Allergy Immunol*. 2015;26(6):557-563.
807. Tsolakis N, Malinovschi A, Nordvall L, et al. Sensitization to minor cat allergen components is associated with type-2 biomarkers in young asthmatics. *Clin Exp Allergy*. 2018;48(9):1186-1194.
808. Patelis A, Gunnbjörnsdóttir M, Alving K, et al. Allergen extract vs. component sensitization and airway inflammation, responsiveness and new-onset respiratory disease. *Clin Exp Allergy*. 2016;46(5):730-740.
809. Wisniewski JA, Agrawal R, Minnicozzi S, et al. Sensitization to food and inhalant allergens in relation to age and wheeze among children with atopic dermatitis. *Clin Exp Allergy*. 2013;43(10):1160-1170.

810. Casale TB, Cruz C. Anaphylaxis to cat in a child with exclusive sensitivity to Fel d 1. *J Allergy Clin Immunol Pract.* 2013;1(4):416-417.
811. Käck U, Asarnej A, Grönlund H, et al. Molecular allergy diagnostics refine characterization of children sensitized to dog dander. *J Allergy Clin Immunol.* 2018;142(4):1113-1120.e1119.
812. Schoos AM, Bønnelykke K, Chawes BL, Stokholm J, Bisgaard H, Kristensen B. Precision allergy: Separate allergies to male and female dogs. *J Allergy Clin Immunol Pract.* 2017;5(6):1754-1756.
813. Schoos AM, Chawes BL, Bloch J, et al. Children Monosensitized to Can f 5 Show Different Reactions to Male and Female Dog Allergen Extract Provocation: A Randomized Controlled Trial. *J Allergy Clin Immunol Pract.* 2020;8(5):1592-1597.e1592.
814. Saarelainen S, Rytönen-Nissinen M, Rouvinen J, et al. Animal-derived lipocalin allergens exhibit immunoglobulin E cross-reactivity. *Clin Exp Allergy.* 2008;38(2):374-381.
815. Schoos AM, Kattan JD, Gimenez G, Sampson HA. Sensitization phenotypes based on protein groups and associations to allergic diseases in children. *J Allergy Clin Immunol.* 2016;137(4):1277-1280.
816. Nordlund B, Konradsen JR, Kull I, et al. IgE antibodies to animal-derived lipocalin, kallikrein and secretoglobulin are markers of bronchial inflammation in severe childhood asthma. *Allergy.* 2012;67(5):661-669.
817. Konradsen JR, Nordlund B, Onell A, Borres MP, Grönlund H, Hedlin G. Severe childhood asthma and allergy to furry animals: refined assessment using molecular-based allergy diagnostics. *Pediatr Allergy Immunol.* 2014;25(2):187-192.
818. Nwaru BI, Suzuki S, Ekerljung L, et al. Furry Animal Allergen Component Sensitization and Clinical Outcomes in Adult Asthma and Rhinitis. *J Allergy Clin Immunol Pract.* 2019;7(4):1230-1238.e1234.
819. Burnett M, Wegienka G, Havstad S, et al. Relationship of dog- and cat-specific IgE and IgG4 levels to allergic symptoms on pet exposure. *J Allergy Clin Immunol Pract.* 2013;1(4):350-353.
820. Zahradnik E, Sander I, Kleinmüller O, et al. Animal Allergens, Endotoxin, and β -(1,3)-Glucan in Small Animal Practices: Exposure Levels at Work and in Homes of Veterinary Staff. *Ann Work Expo Health.* 2022;66(1):27-40.
821. Nilsson OB, Binnmyr J, Zoltowska A, Saarne T, van Hage M, Grönlund H. Characterization of the dog lipocalin allergen Can f 6: the role in cross-reactivity with cat and horse. *Allergy.* 2012;67(6):751-757.
822. Swiontek K, Kler S, Lehnert C, Ollert M, Hentges F, Hilger C. Component-resolved diagnosis using guinea-pig allergens elucidates allergen sensitization profiles in allergy to furry animals. *Clin Exp Allergy.* 2021;51(6):829-835.
823. Hilger C, Kler S, Arumugam K, et al. Identification and isolation of a Fel d 1-like molecule as a major rabbit allergen. *J Allergy Clin Immunol.* 2014;133(3):759-766.
824. Zahradnik E, Sander I, Bruckmaier L, et al. Development of a sandwich ELISA to measure exposure to occupational cow hair allergens. *Int Arch Allergy Immunol.* 2011;155(3):225-233.
825. Uriarte SA, Grönlund H, Wintersand A, Bronge J, Sastre J. Clinical and Immunologic Changes due to Subcutaneous Immunotherapy With Cat and Dog Extracts Using an Ultrarush Up-Dosing Phase: A Real-Life Study. *J Investig Allergol Clin Immunol.* 2022;32(2):133-140.
826. Uriarte SA, Sastre J. Subcutaneous Immunotherapy With High-Dose Cat and Dog Extracts: A Real-life Study. *J Investig Allergol Clin Immunol.* 2020;30(3):169-174.
827. Satyaraj E, Wedner HJ, Bousquet J. Keep the cat, change the care pathway: A transformational approach to managing Fel d 1, the major cat allergen. *Allergy.* 2019;74 Suppl 107(Suppl 107):5-17.
828. Mora C, Tittensor DP, Adl S, Simpson AG, Worm B. How many species are there on Earth and in the ocean? *PLoS Biol.* 2011;9(8):e1001127.
829. Canova C, Heinrich J, Anto JM, et al. The influence of sensitization to pollens and moulds on seasonal variations in asthma attacks. *Eur Respir J.* 2013;42(4):935-945.
830. D'Amato G, Chong-Neto HJ, Monge Ortega OP, et al. The effects of climate change on respiratory allergy and asthma induced by pollen and mold allergens. *Allergy.* 2020;75(9):2219-2228.
831. Holme JA, Øya E, Afanou AKJ, Øvrevik J, Eduard W. Characterization and pro-inflammatory potential of indoor mold particles. *Indoor Air.* 2020;30(4):662-681.
832. Low SY, Dannemiller K, Yao M, Yamamoto N, Peccia J. The allergenicity of *Aspergillus fumigatus* conidia is influenced by growth temperature. *Fungal Biol.* 2011;115(7):625-632.
833. Grewling Ł, Bogawski P, Szymańska A, Nowak M, Kostecki Ł, Smith M. Particle size distribution of the major *Alternaria alternata* allergen, Alt a 1, derived from airborne spores and subspore fragments. *Fungal Biol.* 2020;124(3-4):219-227.
834. Twaroch TE, Arcalís E, Sterflinger K, Stöger E, Swoboda I, Valenta R. Predominant localization of the major *Alternaria* allergen Alt a 1 in the cell wall of airborne spores. *J Allergy Clin Immunol.* 2012;129:1148-1149.
835. O'Driscoll BR, Powell G, Chew F, et al. Comparison of skin prick tests with specific serum immunoglobulin E in the diagnosis of fungal sensitization in patients with severe asthma. *Clin Exp Allergy.* 2009;39(11):1677-1683.
836. Kespohl S, Raulf M. Mold allergens and their importance in molecular allergy diagnosis. In: Kleine-Tebbe J, Jakob T, eds. *Molecular Allergy Diagnostics.* Springer International Publishing Switzerland; 2017:445-458.
837. Chou H, Tam MF, Lee SS, et al. A vacuolar serine protease (Rho m 2) is a major allergen of *Rhodotorula mucilaginosa* and belongs to a class of highly conserved pan-fungal allergens. *Int Arch Allergy Immunol.* 2005;138(2):134-141.
838. Gupta R, Sharma V, Sridhara S, Singh BP, Arora N. Identification of serine protease as a major allergen of *Curvularia lunata*. *Allergy.* 2004;59(4):421-427.
839. Shen HD, Chou H, Tam MF, Chang CY, Lai HY, Wang SR. Molecular and immunological characterization of Pen ch 18, the vacuolar serine protease major allergen of *Penicillium chrysogenum*. *Allergy.* 2003;58(10):993-1002.
840. Simon-Nobbe B, Denk U, Pöll V, Rid R, Breitenbach M. The spectrum of fungal allergy. *Int Arch Allergy Immunol.* 2008;145(1):58-86.
841. Twaroch TE, Curin M, Valenta R, Swoboda I. Mold allergens in respiratory allergy: from structure to therapy. *Allergy Asthma Immunol Res.* 2015;7(3):205-220.
842. Hoff M, Trüeb RM, Ballmer-Weber BK, Vieths S, Wuethrich B. Immediate-type hypersensitivity reaction to ingestion of mycoprotein (Quorn) in a patient allergic to molds caused by acidic ribosomal protein P2. *J Allergy Clin Immunol.* 2003;111(5):1106-1110.
843. Karmakar B, Saha B, Jana K, Gupta BS. Identification and biochemical characterization of Asp t 36, a new fungal allergen from *Aspergillus terreus*. *J Biol Chem.* 2020;295(51):17852-17864.
844. Simon-Nobbe B, Probst G, Kajava AV, et al. IgE-binding epitopes of enolases, a class of highly conserved fungal allergens. *J Allergy Clin Immunol.* 2000;106(5):887-895.
845. Simon-Nobbe B, Denk U, Schneider PB, et al. NADP-dependent mannitol dehydrogenase, a major allergen of *Cladosporium herbarum*. *J Biol Chem.* 2006;281(24):16354-16360.
846. Schneider PB, Denk U, Breitenbach M, et al. *Alternaria alternata* NADP-dependent mannitol dehydrogenase is an important fungal allergen. *Clin Exp Allergy.* 2006;36(12):1513-1524.
847. Hemmann S, Blaser K, Cramer R. Allergens of *Aspergillus fumigatus* and *Candida boidinii* share IgE-binding epitopes. *Am J Respir Crit Care Med.* 1997;156(6):1956-1962.
848. Chou H, Tam MF, Chiang CH, Chou CT, Tai HY, Shen HD. Transaldolases are novel and immunoglobulin E cross-reacting fungal allergens. *Clin Exp Allergy.* 2011;41(5):739-749.

849. Chou H, Wu KG, Yeh CC, et al. The transaldolase, a novel allergen of *Fusarium proliferatum*, demonstrates IgE cross-reactivity with its human analogue. *PLoS One*. 2014;9(7):e103488.
850. Asturias JA II, Ferrer A, et al. Diagnosis of *Alternaria alternata* sensitization with natural and recombinant Alt a 1 allergens. *J Allergy Clin Immunol*. 2005;115:1210-1217. doi:10.1016/j.jaci.2005.02.012
851. Hernandez-Ramirez G, Barber D, Tome-Amat J, Garrido-Arandia M, Diaz-Perales A. *Alternaria* as an Inducer of Allergic Sensitization. *J Fungi (Basel)*. 2021;7(10).
852. Chruszcz M, Chapman MD, Osinski T, et al. *Alternaria alternata* allergen Alt a 1: a unique β -barrel protein dimer found exclusively in fungi. *J Allergy Clin Immunol*. 2012;130(1):241-247.e249.
853. Cramer R. Recombinant *Aspergillus fumigatus* allergens: from the nucleotide sequences to clinical applications. *Int Arch Allergy Immunol*. 1998;115(2):99-114.
854. Cramer R, Hemmann S, Ismail C, Menz G, Blaser K. Disease-specific recombinant allergens for the diagnosis of allergic bronchopulmonary aspergillosis. *Int Immunol*. 1998;10(8):1211-1216.
855. Agarwal R, Chakrabarti A, Shah A, et al. Allergic bronchopulmonary aspergillosis: review of literature and proposal of new diagnostic and classification criteria. *Clin Exp Allergy*. 2013;43(8):850-873.
856. Muthu V, Singh P, Choudhary H, et al. Diagnostic Cutoffs and Clinical Utility of Recombinant *Aspergillus fumigatus* Antigens in the Diagnosis of Allergic Bronchopulmonary Aspergillosis. *J Allergy Clin Immunol Pract*. 2020;8(2):579-587.
857. Esch RE, Codina R. Fungal raw materials used to produce allergen extracts. *Ann Allergy Asthma Immunol*. 2017;118(4):399-405.
858. Kespohl S, Maryska S, Zahradnik E, Sander I, Brüning T, Raulf-Heimsoth M. Biochemical and immunological analysis of mould skin prick test solution: current status of standardization. *Clin Exp Allergy*. 2013;43(11):1286-1296.
859. Vailes LD, Perzanowski MS, Wheatley LM, Platts-Mills TA, Chapman MD. IgE and IgG antibody responses to recombinant Alt a 1 as a marker of sensitization to *Alternaria* in asthma and atopic dermatitis. *Clin Exp Allergy*. 2001;31(12):1891-1895.
860. López Couso VP, Tortajada-Girbés M, Rodríguez Gil D, Martínez Quesada J, Palacios PR. Fungi Sensitization in Spain: Importance of the *Alternaria alternata* Species and Its Major Allergen Alt a 1 in the Allergenicity. *J Fungi (Basel)*. 2021;7(8).
861. Tabar AI, Prieto L, Alba P, et al. Double-blind, randomized, placebo-controlled trial of allergen-specific immunotherapy with the major allergen Alt a 1. *J Allergy Clin Immunol*. 2019;144(1):216-223.e213.
862. Morales-Amparano MB, Huerta-Ocampo J, Pastor-Palacios G, Teran LM. The Role of Enolases in Allergic Disease. *J Allergy Clin Immunol Pract*. 2021;9(8):3026-3032.
863. Muthu V, Sehgal IS, Dhooria S, Aggarwal AN, Agarwal R. Utility of recombinant *Aspergillus fumigatus* antigens in the diagnosis of allergic bronchopulmonary aspergillosis: A systematic review and diagnostic test accuracy meta-analysis. *Clin Exp Allergy*. 2018;48(9):1107-1136.
864. Joest M. Allergic bronchopulmonary aspergillosis (ABPA) in an atopic patient with difficult-to-expectorate airway secretions. *Allergol Select*. 2021;5:157-161.
865. Rosenberg M, Patterson R, Mintzer R, Cooper BJ, Roberts M, Harris KE. Clinical and immunologic criteria for the diagnosis of allergic bronchopulmonary aspergillosis. *Ann Intern Med*. 1977;86(4):405-414.
866. Kurup VP, Banerjee B, Hemmann S, Greenberger PA, Blaser K, Cramer R. Selected recombinant *Aspergillus fumigatus* allergens bind specifically to IgE in ABPA. *Clin Exp Allergy*. 2000;30(7):988-993.
867. Klimek L, Werfel T, Vogelberg C, Jung K. Authorised allergen products for intracutaneous testing may no longer be available in Germany: Allergy textbooks have to be re-written. *Allergo J Int*. 2015;24(3):84-93.
868. Kespohl S, Liebers V, Maryska S, et al. What should be tested in patients with suspected mold exposure? Usefulness of serological markers for the diagnosis. *Allergol Select*. 2022;6:118-132.
869. Kespohl S, Raulf M. Mold Sensitization in Asthmatic and Non-asthmatic Subjects Diagnosed with Extract-Based Versus Component-Based Allergens. *Adv Exp Med Biol*. 2019;1153:79-89.
870. Oh J, Byrd AL, Deming C, et al. Biogeography and individuality shape function in the human skin metagenome. *Nature*. 2014;514(7520):59-64.
871. De Benedetto A, Kubo A, Beck LA. Skin barrier disruption: a requirement for allergen sensitisation? *J Invest Dermatol*. 2012;132(3 Pt 2):949-963.
872. Kong HH, Oh J, Deming C, et al. Temporal shifts in the skin microbiome associated with disease flares and treatment in children with atopic dermatitis. *Genome Res*. 2012;22(5):850-859.
873. Langan SM, Irvine AD, Weidinger S. Atopic dermatitis. *Lancet*. 2020;396(10247):345-360.
874. Laughter MR, Maymone MBC, Mashayekhi S, et al. The global burden of atopic dermatitis: lessons from the Global Burden of Disease Study 1990-2017. *Br J Dermatol*. 2021;184(2):304-309.
875. Patrick GJ, Archer NK, Miller LS. Which Way Do We Go? Complex Interactions in Atopic Dermatitis Pathogenesis. *J Invest Dermatol*. 2021;141(2):274-284.
876. Brodská P, Panzner P, Pizinger K, Schmid-Grendelmeier P. IgE-mediated sensitization to malassezia in atopic dermatitis: more common in male patients and in head and neck type. *Dermatitis*. 2014;25(3):120-126.
877. Glatz M, Buchner M, von Bartenwerffer W, et al. Malassezia spp.-specific immunoglobulin E level is a marker for severity of atopic dermatitis in adults. *Acta Derm Venereol*. 2015;95(2):191-196.
878. Kaffenberger BH, Mathis J, Zirwas MJ. A retrospective descriptive study of oral azole antifungal agents in patients with patch test-negative head and neck predominant atopic dermatitis. *J Am Acad Dermatol*. 2014;71(3):480-483.
879. Cabañes FJ. Malassezia yeasts: how many species infect humans and animals? *PLoS Pathog*. 2014;10(2):e1003892.
880. Saunders CW, Scheynius A, Heitman J. Malassezia fungi are specialized to live on skin and associated with dandruff, eczema, and other skin diseases. *PLoS Pathog*. 2012;8(6):e1002701.
881. Findley K, Oh J, Yang J, et al. Topographic diversity of fungal and bacterial communities in human skin. *Nature*. 2013;498(7454):367-370.
882. Gaitanis G, Magiatis P, Hantschke M, Bassukas ID, Velegriaki A. The Malassezia genus in skin and systemic diseases. *Clin Microbiol Rev*. 2012;25(1):106-141.
883. Glatz M, Bosshard PP, Hoetzenecker W, Schmid-Grendelmeier P. The Role of Malassezia spp. in Atopic Dermatitis. *J Clin Med*. 2015;4(6):1217-1228.
884. Lang CCV, Masenga J, Semango G, et al. Evidence for different immune signatures and sensitization patterns in sub-Saharan African vs. Central European atopic dermatitis patients. *J Eur Acad Dermatol Venereol*. 2021;35(2):e140-e142.
885. Glaser AG, Limacher A, Flückiger S, Scheynius A, Scapozza L, Cramer R. Analysis of the cross-reactivity and of the 1.5 A crystal structure of the Malassezia sympodialis Mala s 6 allergen, a member of the cyclophilin pan-allergen family. *Biochem J*. 2006;396(1):41-49.
886. Limacher A, Glaser AG, Meier C, et al. Cross-reactivity and 1.4-A crystal structure of Malassezia sympodialis thioredoxin (Mala s 13), a member of a new pan-allergen family. *J Immunol*. 2007;178(1):389-396.
887. Vilhelmsson M, Glaser AG, Martinez DB, et al. Mutational analysis of amino acid residues involved in IgE-binding to the Malassezia sympodialis allergen Mala s 11. *Mol Immunol*. 2008;46(2):294-303.

888. Schmid-Grendelmeier P, Flückiger S, Disch R, et al. IgE-mediated and T cell-mediated autoimmunity against manganese superoxide dismutase in atopic dermatitis. *J Allergy Clin Immunol*. 2005;115(5):1068-1075.
889. Altrichter S, Schumacher P, Araboni O, et al. Sensitization against skin resident fungi is associated with atopy in cholinergic urticaria patients. *Clin Transl Allergy*. 2020;10:18.
890. Johansson C, Sandström MH, Bartosik J, et al. Atopy patch test reactions to Malassezia allergens differentiate subgroups of atopic dermatitis patients. *Br J Dermatol*. 2003;148(3):479-488.
891. Sehna D, Bittrich S, Deshpande M, et al. Mol* Viewer: modern web app for 3D visualization and analysis of large biomolecular structures. *Nucleic Acids Res*. 2021;49:W431-W437. doi:10.1093/nar/gkab314
892. Scheynius A, Johansson C, Buentke E, Zargari A, Linder MT. Atopic eczema/dermatitis syndrome and Malassezia. *Int Arch Allergy Immunol*. 2002;127(3):161-169.
893. Darabi K, Hostetler SG, Bechtel MA, Zirwas M. The role of Malassezia in atopic dermatitis affecting the head and neck of adults. *J Am Acad Dermatol*. 2009;60(1):125-136.
894. Selander C, Zargari A, Möllby R, Rasool O, Scheynius A. Higher pH level, corresponding to that on the skin of patients with atopic eczema, stimulates the release of Malassezia sympodialis allergens. *Allergy*. 2006;61(8):1002-1008.
895. Ramirez de Knott HM, McCormick TS, Kalka K, et al. Cutaneous hypersensitivity to Malassezia sympodialis and dust mite in adult atopic dermatitis with a textile pattern. *Contact Dermatitis*. 2006;54(2):92-99.
896. Svejgaard E, Larsen P, Deleuran M, Ternowitz T, Roed-Petersen J, Nilsson J. Treatment of head and neck dermatitis comparing itraconazole 200 mg and 400 mg daily for 1 week with placebo. *J Eur Acad Dermatol Venereol*. 2004;18(4):445-449.
897. Lintu P, Savolainen J, Kortekangas-Savolainen O, Kalimo K. Systemic ketoconazole is an effective treatment of atopic dermatitis with IgE-mediated hypersensitivity to yeasts. *Allergy*. 2001;56(6):512-517.
898. Buttafuoco A, Schmid-Grendelmeier P, Glatz M. *Ther Umsch*. 2016;73:463-468.
899. Sparber F, De Gregorio C, Steckholzer S, et al. The skin commensal yeast malassezia triggers a type 17 response that coordinates anti-fungal immunity and exacerbates skin inflammation. *Cell Host Microbe*. 2019;25(3):389-403.
900. Balaji H, Heratizadeh A, Wichmann K, et al. Malassezia sympodialis thioredoxin-specific T cells are highly cross-reactive to human thioredoxin in atopic dermatitis. *J Allergy Clin Immunol*. 2011;128(1):92-99.e94.
901. Bjerre RD, Bandier J, Skov L, Engstrand L, Johansen JD. The role of the skin microbiome in atopic dermatitis: a systematic review. *Br J Dermatol*. 2017;177(5):1272-1278.
902. Nordengrün MMS, Völker U, Bröker BM, Gómez-Gascón L. The quest for bacterial allergens. *Int J Med Microbiol*. 2018;308(6):738-750.
903. Rachid RS-VE, Chatila TA. The microbial origins of food allergy. *J Allergy Clin Immunol*. 2021;147(3):808-813. doi:10.1016/j.jaci.2020.12.624
904. Hoh RAJS, Lee J-Y, Martin BA, et al. Origins and clonal convergence of gastrointestinal IgE⁺ B cells in human peanut allergy. *Sci Immunol*. 2020;5(45):eaay4209.
905. Petersen J, Ciacchi L, Tran MT, et al. T cell receptor cross-reactivity between gliadin and bacterial peptides in celiac disease. *Nat Struct Mol Biol*. 2020;27(1):49-61.
906. Hua XGJ, Pu A, Yu G, Shi J. Allergy associations with the adult fecal microbiota: analysis of the American Gut Project. *EBioMedicine*.
907. FAO/WHO. *Edible Insects. Future Prospects for Food and Feed Security*. Food and Agriculture Organization of the United Nations; 2013:171.
908. Jongema Y. World list of edible insects. 2017. https://www.wur.nl/upload_mm/8/a/6/0fdcf700-3929-4a74-8b69-f02fd35a1696-Worldwide%20list%20of%20edible%20insects%202017.pdf
909. Czolk R, Klueber J, Sørensen M, et al. IgE-mediated peanut allergy: current and novel predictive biomarkers for clinical phenotypes using multi-omics approaches. *Front Immunol*. 2021;11(3653):594350.
910. FDA. *Food Defect Levels Handbook*. FDA; 2018.
911. EFSA Panel on Dietetic Products NaANP, Nutrition, Nda A et al. Guidance on the preparation and submission of an application for authorisation of a novel food in the context of Regulation (EU) 2015/2283 (Revision 1)2. *EFSA J*. 2021;19(3):e06555. doi:10.2903/j.efsa.2021.6555
912. EFSA Panel on Nutrition NFAFAN, Turck D, Castenmiller J, et al. Safety of dried yellow mealworm (*Tenebrio molitor* larva) as a novel food pursuant to Regulation (EU) 2015/2283. *EFSA J*. 2021;19(1):e06343. doi:10.2903/j.efsa.2021.6343
913. Barennes H, Phimmassane M, Rajaonarivo C. Insect Consumption to Address Undernutrition, a National Survey on the Prevalence of Insect Consumption among Adults and Vendors in Laos. *PLoS One*. 2015;10(8):e0136458.
914. Ji K, Chen J, Li M, et al. Anaphylactic shock and lethal anaphylaxis caused by food consumption in China. *Trends Food Sci Technol*. 2009;20(5):227-231.
915. Lee SC, Kim SR, Park KH, Lee JH, Park JW. Clinical Features and Culprit Food Allergens of Korean Adult Food Allergy Patients: A Cross-Sectional Single-Institute Study. *Allergy Asthma Immunol Res*. 2019;11(5):723-735.
916. Jeong KY, Hong CS, Yong TS. Domestic arthropods and their allergens. *Protein Pept Lett*. 2007;14(10):934-942.
917. De Marchi L, Wangorsch A, Zoccatelli G. Allergens from Edible Insects: Cross-reactivity and Effects of Processing. *Curr Allergy Asthma Rep*. 2021;21(5):35.
918. Broekman H, Knulst AC, den Hartog Jager CF, et al. Primary respiratory and food allergy to mealworm. *J Allergy Clin Immunol*. 2017;140(2):600-603.e607.
919. Verhoecx K, Broekman H, Knulst A, Houben G. Allergenicity assessment strategy for novel food proteins and protein sources. *Regul Toxicol Pharmacol*. 2016;79:118-124.
920. Phiriyangkul P et al. Effect of food thermal processing on allergenicity proteins in Bombay locust (*Patanga Succincta*). *Int J Food Eng*. 2015;1:23-28. doi:10.18178/ijfe.1.1.23-28
921. Kamemura N, Sugimoto M, Tamehiro N, et al. Cross-allergenicity of crustacean and the edible insect *Gryllus bimaculatus* in patients with shrimp allergy. *Mol Immunol*. 2019;106:127-134.
922. de Las Marinas MD, Cerdá JC, López-Matas MA, et al. Hexamerin-like protein 2, a cricket allergen involved in occupational and food allergy. *Clin Exp Allergy*. 2021;51(6):858-860.
923. De Marchi L, Mainente F, Leonardi M, et al. Allergenicity assessment of the edible cricket *Acheta domesticus* in terms of thermal and gastrointestinal processing and IgE cross-reactivity with shrimp. *Food Chem*. 2021;359:129878.
924. Srinroch C, Srisomsap C, Chokchaichamnankit D, Punyarit P, Phiriyangkul P. Identification of novel allergen in edible insect, *Gryllus bimaculatus* and its cross-reactivity with *Macrobrachium* spp. allergens. *Food Chem*. 2015;184:160-166.
925. Azzi A, Clark SA, Ellington WR, Chapman MS. The role of phosphagen specificity loops in arginine kinase. *Protein Sci*. 2004;13(3):575-585.
926. Zhao X, Li L, Kuang Z, Luo G, Li B. Proteomic and immunological identification of two new allergens from silkworm (*Bombyx mori* L.) pupae. *Cent Eur J Immunol*. 2015;40(1):30-34.
927. Jeong KY, Son M, Lee JY, Park KH, Lee JH, Park JW. Allergenic characterization of 27-kDa glycoprotein, a novel heat stable allergen, from the pupa of silkworm, *Bombyx mori*. *J Korean Med Sci*. 2016;31(1):18-24.

928. Leoni C, Volpicella M, Dileo M, Gattulli BAR, Ceci LR. Chitinases as Food Allergens. *Molecules*. 2019;24(11).
929. Li MX, Hwang PM. Structure and function of cardiac troponin C (TNNC1): Implications for heart failure, cardiomyopathies, and troponin modulating drugs. *Gene*. 2015;571(2):153-166.
930. Burmester T. Evolution and function of the insect hexamerins. *EJE*. 1999;96(3):213-225.
931. Rane AS, Joshi RS, Giri AP. Molecular determinant for specificity: Differential interaction of α -amylases with their proteinaceous inhibitors. *Biochim Biophys Acta Gen Subj*. 1864;2020(12):129703.
932. Barre A, Pichereaux C, Simplicien M, Burllet-Schiltz O, Benoist H, Rougé P. A Proteomic- and Bioinformatic-Based Identification of Specific Allergens from Edible Insects: Probes for Future Detection as Food Ingredients. *Foods*. 2021;10(2).
933. de Gier S, Verhoeckx K. Insect (food) allergy and allergens. *Mol Immunol*. 2018;100:82-106.
934. Broekman H, Verhoeckx KC, den Hartog Jager CF, et al. Majority of shrimp-allergic patients are allergic to mealworm. *J Allergy Clin Immunol*. 2016;137(4):1261-1263.
935. Broekman H, Knulst AC, de Jong G, et al. Is mealworm or shrimp allergy indicative for food allergy to insects? *Mol Nutr Food Res*. 2017;61(9).
936. Nebbia S, Lamberti C, Giorgis V, et al. The cockroach allergen-like protein is involved in primary respiratory and food allergy to yellow mealworm (*Tenebrio molitor*). *Clin Exp Allergy*. 2019;49(10):1379-1382.
937. Bose U, Broadbent JA, Juhász A, et al. Protein extraction protocols for optimal proteome measurement and arginine kinase quantitation from cricket *Acheta domestica* for food safety assessment. *Food Chem*. 2021;348:129110.
938. Broekman H, Knulst A, den Hartog JS, et al. Effect of thermal processing on mealworm allergenicity. *Mol Nutr Food Res*. 2015;59(9):1855-1864.
939. Pali-Schöll I, Meinschmidt P, Larenas-Linnemann D, et al. Edible insects: Cross-recognition of IgE from crustacean- and house dust mite allergic patients, and reduction of allergenicity by food processing. *World Allergy Organ J*. 2019;12(1):100006.
940. Mankouri F, Sereme Y, Michel M, et al. Immediate Hypersensitivity to Mealworm and Cricket: Beyond Shrimp and House Dust Mite Cross-Reactivity. *J Investig Allergol Clin Immunol*. 2021;32(1):64-66.
941. Kung SJ, Fenemore B, Potter PC. Anaphylaxis to Mopane worms (*Imbrasia belina*). *Ann Allergy Asthma Immunol*. 2011;106:538-540.
942. Hustinx-Broekman HCHP, *Allergenic risks of mealworm and other insects*, in *Universiteit Utrecht*. doctoral thesis 201. *Allergenic risks of mealworm and other insects*, in *Universiteit Utrecht*. doctoral thesis 2017, Utrecht. <https://dspace.library.uu.nl/handle/1874/349295>.
943. Boyce JA, Assa'ad A, Burks AW, et al. Guidelines for the Diagnosis and Management of Food Allergy in the United States: Summary of the NIAID-Sponsored Expert Panel Report. *J Allergy Clin Immunol*. 2010;126(6):1105-1118.
944. Schoemaker AA, Sprikkelman AB, Grimshaw KE, et al. Incidence and natural history of challenge-proven cow's milk allergy in European children—EuroPrevall birth cohort. *Allergy*. 2015;70(8):963-972.
945. Restani P, Beretta B, Fiocchi A, Ballabio C, Galli CL. Cross-reactivity between mammalian proteins. *Ann Allergy Asthma Immunol*. 2002;89(6 Suppl 1):11-15.
946. Tsabouri S, Douros K, Priftis KN. Cow's milk allergenicity. *Endocr Metab Immune Disord Drug Targets*. 2014;14(1):16-26.
947. Fiocchi A, Dahdah L, Albarini M, Martelli A. Cow's milk allergy in children and adults. *Chem Immunol Allergy*. 2015;101:114-123.
948. Bloom KA, Huang FR, Bencharitiwong R, et al. Effect of heat treatment on milk and egg proteins allergenicity. *Pediatr Allergy Immunol*. 2014;25(8):740-746.
949. Bijl E, van Valenberg HJ, Huppertz T, van Hooijdonk AC. Protein, casein, and micellar salts in milk: current content and historical perspectives. *J Dairy Sci*. 2013;96(9):5455-5464.
950. de Kruijf CG, Huppertz T, Urban VS, Petukhov AV. Casein micelles and their internal structure. *Adv Colloid Interface Sci*. 2012;171-172:36-52.
951. Werfel SJ, Cooke SK, Sampson HA. Clinical reactivity to beef in children allergic to cow's milk. *J Allergy Clin Immunol*. 1997;99(3):293-300.
952. Restani P, Ballabio C, Tripodi S, Fiocchi A. Meat allergy. *Curr Opin Allergy Clin Immunol*. 2009;9(3):265-269.
953. Restani P, Ballabio C, Di Lorenzo C, Tripodi S, Fiocchi A. Molecular aspects of milk allergens and their role in clinical events. *Anal Bioanal Chem*. 2009;395(1):47-56.
954. Vicente-Serrano J, Caballero ML, Rodríguez-Pérez R, et al. Sensitization to serum albumins in children allergic to cow's milk and epithelia. *Pediatr Allergy Immunol*. 2007;18(6):503-507.
955. Chatchatee P, Järvinen KM, Bardina L, Vila L, Beyer K, Sampson HA. Identification of IgE and IgG binding epitopes on beta- and kappa-casein in cow's milk allergic patients. *Clin Exp Allergy*. 2001;31(8):1256-1262.
956. Chatchatee P, Järvinen KM, Bardina L, Beyer K, Sampson HA. Identification of IgE- and IgG-binding epitopes on alpha(s1)-casein: differences in patients with persistent and transient cow's milk allergy. *J Allergy Clin Immunol*. 2001;107(2):379-383.
957. Lorenz AR, Scheurer S, Vieths S. Food allergens: molecular and immunological aspects, allergen databases and cross-reactivity. *Chem Immunol Allergy*. 2015;101:18-29.
958. Kim JS, Nowak-Węgrzyn A, Sicherer SH, Noone S, Moshier EL, Sampson HA. Dietary baked milk accelerates the resolution of cow's milk allergy in children. *J Allergy Clin Immunol*. 2011;128(1):125-131.e122.
959. Ford LS, Bloom KA, Nowak-Węgrzyn AH, Shreffler WG, Masilamani M, Sampson HA. Basophil reactivity, wheal size, and immunoglobulin levels distinguish degrees of cow's milk tolerance. *J Allergy Clin Immunol*. 2013;131(1):180-186.e181-183.
960. Caubet JC, Nowak-Węgrzyn A, Moshier E, Godbold J, Wang J, Sampson HA. Utility of casein-specific IgE levels in predicting reactivity to baked milk. *J Allergy Clin Immunol*. 2013;131(1):222-224.e221-224.
961. Wang J, Lin J, Bardina L, et al. Correlation of IgE/IgG4 milk epitopes and affinity of milk-specific IgE antibodies with different phenotypes of clinical milk allergy. *J Allergy Clin Immunol*. 2010;125(3):695-702. 702.e691-702.e696.
962. Wanich N, Nowak-Węgrzyn A, Sampson HA, Shreffler WG. Allergen-specific basophil suppression associated with clinical tolerance in patients with milk allergy. *J Allergy Clin Immunol*. 2009;123(4):789-794.e720.
963. Mack DP, Chan ES, Shaker M, et al. Novel Approaches to Food Allergy Management During COVID-19 Inspire Long-Term Change. *J Allergy Clin Immunol Pract*. 2020;8(9):2851-2857.
964. Ball HB, Luyt D. Home-based cow's milk reintroduction using a milk ladder in children less than 3 years old with IgE-mediated cow's milk allergy. *Clin Exp Allergy*. 2019;49(6):911-920.
965. Mac Mahon J, Hourihane JO, Byrne A. A virtual management approach to infant egg allergy developed in response to pandemic-imposed restrictions. *Clin Exp Allergy*. 2021;51:360-363.
966. Yonkof JR, Mikhail IJ, Prince BT, Stukus D. Delayed and Severe Reactions to Baked Egg and Baked Milk Challenges. *J Allergy Clin Immunol Pract*. 2021;9(1):283-289.e282.
967. Nowak-Węgrzyn A, Lawson K, Masilamani M, Kattan J, Bahnson HT, Sampson HA. Increased Tolerance to Less Extensively Heat-Denatured (Baked) Milk Products in Milk-Allergic Children. *J Allergy Clin Immunol Pract*. 2018;6(2):486-495.e485.
968. D'Auria E, Salvatore S, Pozzi E, et al. Cow's Milk Allergy: Immunomodulation by Dietary Intervention. *Nutrients*. 2019;11(6).

969. Groetch M, Nowak-Węgrzyn A. Practical approach to nutrition and dietary intervention in pediatric food allergy. *Pediatr Allergy Immunol*. 2013;24(3):212-221.
970. Dupont C, Kalach N, Soullains P, Legoué-Morillon S, Piloquet H, Benhamou PH. Cow's milk epicutaneous immunotherapy in children: a pilot trial of safety, acceptability, and impact on allergic reactivity. *J Allergy Clin Immunol*. 2010;125:1165-1167.
971. Shek LP, Soderstrom L, Ahlstedt S, Beyer K, Sampson HA. Determination of food specific IgE levels over time can predict the development of tolerance in cow's milk and hen's egg allergy. *J Allergy Clin Immunol*. 2004;114(2):387-391.
972. Skripak JM, Matsui EC, Mudd K, Wood RA. The natural history of IgE-mediated cow's milk allergy. *J Allergy Clin Immunol*. 2007;120(5):1172-1177.
973. Leung J, Hundal NV, Katz AJ, et al. Tolerance of baked milk in patients with cow's milk-mediated eosinophilic esophagitis. *J Allergy Clin Immunol*. 2013;132(5):1215-1216.e1211.
974. Martelli A, De Chiara A, Corvo M, Restani P, Fiocchi A. Beef allergy in children with cow's milk allergy; cow's milk allergy in children with beef allergy. *Ann Allergy Asthma Immunol*. 2002;89(6 Suppl 1):38-43.
975. Commins SP, Satinover SM, Hosen J, et al. Delayed anaphylaxis, angioedema, or urticaria after consumption of red meat in patients with IgE antibodies specific for galactose-alpha-1,3-galactose. *J Allergy Clin Immunol*. 2009;123(2):426-433. doi:10.1016/j.jaci.2008.10.052
976. Savage J, Johns CB. Food allergy: epidemiology and natural history. *Immunol Allergy Clin North Am*. 2015;35(1):45-59.
977. Savage J, Sicherer S, Wood R. The Natural History of Food Allergy. *J Allergy Clin Immunol Pract*. 2016;4(2):196-203. quiz 204.
978. Abrams EM, Sicherer SH. Cow's milk allergy prevention. *Ann Allergy Asthma Immunol*. 2021;127(1):36-41.
979. Wood RA, Sicherer SH, Vickery BP, et al. The natural history of milk allergy in an observational cohort. *J Allergy Clin Immunol*. 2013;131(3):805-812.
980. Høst A, Halcken S, Jacobsen HP, Christensen AE, Herskind AM, Plesner K. Clinical course of cow's milk protein allergy/intolerance and atopic diseases in childhood. *Pediatr Allergy Immunol*. 2002;13(s15):23-28.
981. Lam HY, van Hoffen E, Michelsen A, et al. Cow's milk allergy in adults is rare but severe: both casein and whey proteins are involved. *Clin Exp Allergy*. 2008;38(6):995-1002.
982. Halcken S, Muraro A, de Silva D, et al. EAACI guideline: Preventing the development of food allergy in infants and young children (2020 update). *Pediatr Allergy Immunol*. 2021;32(5):843-858.
983. Sakihara T, Otsuji K, Arakaki Y, Hamada K, Sugiura S, Ito K. Randomized trial of early infant formula introduction to prevent cow's milk allergy. *J Allergy Clin Immunol*. 2021;147(1):224-232.e228.
984. Albin S, Nowak-Węgrzyn A. Potential treatments for food allergy. *Immunol Allergy Clin North Am*. 2015;35(1):77-100.
985. Pajno GBF-RM, Arasi S, et al. EAACI Allergen Immunotherapy Guidelines Group. EAACI Guidelines on allergen immunotherapy: IgE-mediated food allergy. *Allergy*. 2018;73(4):799-815. doi:10.1111/all.13319
986. Escudero C, Quirce S, Fernández-Nieto M, Miguel J, Cuesta J, Sastre J. Egg white proteins as inhalant allergens associated with baker's asthma. *Allergy*. 2003;58(7):616-620.
987. Brough HA, Santos AF, Makinson K, et al. Peanut protein in household dust is related to household peanut consumption and is biologically active. *J Allergy Clin Immunol*. 2013;132(3):630-638.
988. Ballmer-Weber BK, Fernandez-Rivas M, Beyer K, et al. How much is too much? Threshold dose distributions for 5 food allergens. *J Allergy Clin Immunol*. 2015;135(4):964-971.
989. Logan K, Du Toit G, Giovannini M, Turcanu V, Lack G. Pediatric Allergic Diseases, Food Allergy, and Oral Tolerance. *Annu Rev Cell Dev Biol*. 2020;36:511-528.
990. Martorell Aragonés A, Boné Calvo J, CGA M, Nevot Falcó S, MPM A. Allergy to egg proteins. *Allergol Immunopathol (Madr)*. 2001;29(2):84-95.
991. Cooke SK, Sampson HA. Allergenic properties of ovomucoid in man. *J Immunol*. 1997;159(4):2026-2032.
992. Mine Y, Yang M. Recent advances in the understanding of egg allergens: basic, industrial, and clinical perspectives. *J Agric Food Chem*. 2008;56(13):4874-4900.
993. Urisu A, Ando H, Morita Y, et al. Allergenic activity of heated and ovomucoid-depleted egg white. *J Allergy Clin Immunol*. 1997;100(2):171-176.
994. Eigenmann PA. Anaphylactic reactions to raw eggs after negative challenges with cooked eggs. *J Allergy Clin Immunol*. 2000;105(3):587-588.
995. Calvani M, Arasi S, Bianchi A, et al. Is it possible to make a diagnosis of raw, heated, and baked egg allergy in children using cutoffs? A systematic review. *Pediatr Allergy Immunol*. 2015;26(6):509-521.
996. Benhamou AH, Caubet JC, Eigenmann PA, et al. State of the art and new horizons in the diagnosis and management of egg allergy. *Allergy*. 2010;65(3):283-289.
997. Eigenmann PA. Are specific immunoglobulin E titres reliable for prediction of food allergy? *Clin Exp Allergy*. 2005;35:247-249.
998. Sampson HA. Utility of food-specific IgE concentrations in predicting symptomatic food allergy. *J Allergy Clin Immunol*. 2001;107(5):891-896.
999. Boyano Martínez T, García-Ara C, Díaz-Pena JM, Muñoz FM, García Sánchez G, Esteban MM. Validity of specific IgE antibodies in children with egg allergy. *Clin Exp Allergy*. 2001;31(9):1464-1469.
1000. Celik-Bilgili S, Mehl A, Verstege A, et al. The predictive value of specific immunoglobulin E levels in serum for the outcome of oral food challenges. *Clin Exp Allergy*. 2005;35(3):268-273.
1001. Benhamou AH, Zamora SA, Eigenmann PA. Correlation between specific immunoglobulin E levels and the severity of reactions in egg allergic patients. *Pediatr Allergy Immunol*. 2008;19(2):173-179.
1002. Ando H, Movérare R, Kondo Y, et al. Utility of ovomucoid-specific IgE concentrations in predicting symptomatic egg allergy. *J Allergy Clin Immunol*. 2008;122(3):583-588.
1003. Benhamou Senouf AH, Borres MP, Eigenmann PA. Native and denatured egg white protein IgE tests discriminate hen's egg allergic from egg-tolerant children. *Pediatr Allergy Immunol*. 2015;26(1):12-17.
1004. Sirin Kose S, Asilsoy S, Uzuner N, Karaman O, Anal O. Outcomes of Baked Milk and Egg Challenge in Cow's Milk and Hen's Egg Allergy: Can Tolerance Be Predicted with Allergen-Specific IgE and Prick-to-Prick Test? *Int Arch Allergy Immunol*. 2019;180(4):264-273.
1005. Dang TD, Peters RL, Koplin JJ, et al. Egg allergen specific IgE diversity predicts resolution of egg allergy in the population cohort HealthNuts. *Allergy*. 2019;74(2):318-326.
1006. Gradman J, Mortz CG, Eller E, Bindslev-Jensen C. Relationship between specific IgE to egg components and natural history of egg allergy in Danish children. *Pediatr Allergy Immunol*. 2016;27(8):825-830.
1007. Sicherer SH, Wood RA, Vickery BP, et al. The natural history of egg allergy in an observational cohort. *J Allergy Clin Immunol*. 2014;133(2):492-499.
1008. Pérez-Quintero O, Martínez-Azcona O, Balboa V, Vila L. Daily baked egg intake may accelerate the development of tolerance to raw egg in egg-allergic children. *Eur J Pediatr*. 2020;179(4):679-682.
1009. Kuehn A, Scheuermann T, Hilger C, Hentges F. Important variations in parvalbumin content in common fish species: a factor possibly contributing to variable allergenicity. *Int Arch Allergy Immunol*. 2010;153(4):359-366.
1010. Ruethers T, Taki AC, Karnaneedi S, et al. Expanding the allergen repertoire of salmon and catfish. *Allergy*. 2021;76(5):1443-1453.

1011. Hanaoka K, Takahagi S, Ishii K, et al. Type-I-hypersensitivity to 15 kDa, 28 kDa and 54 kDa proteins in vitellogenin specific to *Gadus chalcogrammus* roe. *Allergol Int*. 2020;69(2):253-260.
1012. Kalic T, Kamath SD, Ruethers T, et al. Collagen-An Important Fish Allergen for Improved Diagnosis. *J Allergy Clin Immunol Pract*. 2020;8(9):3084-3092.e3010.
1013. Douglas JD, McSharry C, Blaikie L, Morrow T, Miles S, Franklin D. Occupational asthma caused by automated salmon processing. *Lancet*. 1995;346(8977):737-740.
1014. Mason HJ, Carder M, Money A, et al. Occupational Asthma and Its Causation in the UK Seafood Processing Industry. *Ann Work Expo Health*. 2020;64(8):817-825.
1015. Ruethers T, Taki AC, Johnston EB, et al. Seafood allergy: A comprehensive review of fish and shellfish allergens. *Mol Immunol*. 2018;100:28-57.
1016. Peixoto S, Monteiro T, Carvalho M, et al. Vertebrate Tropomyosin as an Allergen. *J Investig Allergol Clin Immunol*. 2018;28(1):51-53.
1017. Aibinu IE, Smooker PM, Lopata AL. Anisakis Nematodes in Fish and Shellfish- from infection to allergies. *Int J Parasitol Parasites Wildl*. 2019;9:384-393.
1018. Davis CM, Gupta RS, Aktas ON, Diaz V, Kamath SD, Lopata AL. Clinical Management of Seafood Allergy. *J Allergy Clin Immunol Pract*. 2020;8(1):37-44.
1019. Debenedetti ÁL, Madrid E, Trelis M, et al. Prevalence and risk of anisakid larvae in fresh fish frequently consumed in Spain: an overview. *Fishes*. 2019;4:1-16.
1020. Lanfranchi AL, Sardella NH. Anisakids survival after microwaving, freezing and salting fish from Argentina. *Food Sci Technol Res*. 2010;16:499-504.
1021. Audicana MT, Ansotegui IJ, de Corres LF, Kennedy MW. Anisakis simplex: dangerous-dead and alive? *Trends Parasitol*. 2002;18(1):20-25.
1022. Dickel H, Kuehn A, Dickel B, et al. Assessment of the effects of a work-related allergy to seafood on the reduction of earning capacity in the context of BK No. 5101. *Allergol Select*. 2021;5:33-44.
1023. Bonlokke JH, Bang B, Aasmoe L, et al. Exposures and Health Effects of Bioaerosols in Seafood Processing Workers - a Position Statement. *J Agromedicine*. 2019;24(4):441-448.
1024. Kuehn A, Hilger C, Lehnert-Weber C, et al. Identification of enolases and aldolases as important fish allergens in cod, salmon and tuna: component resolved diagnosis using parvalbumin and the new allergens. *Clin Exp Allergy*. 2013;43(7):811-822.
1025. Kuehn A, Hilger C, Hentges F. Anaphylaxis provoked by ingestion of marshmallows containing fish gelatin. *J Allergy Clin Immunol*. 2009;123:708-709.
1026. Ueno R, Takaoka Y, Shimojo N, et al. A case of pediatric anaphylaxis caused by gummy tablets containing fish collagen. *Asia Pac Allergy*. 2020;10:e35.
1027. Fæste CK, Jonscher KR, Dooper MM, et al. Characterisation of potential novel allergens in the fish parasite *Anisakis simplex*. *EuPA Open Proteom*. 2014;4:140-155.
1028. Armentia A, Santos J, Serrano Z, et al. Molecular diagnosis of allergy to *Anisakis simplex* and *Gymnorhynchus gigas* fish parasites. *Allergol Immunopathol (Madr)*. 2017;45(5):463-472.
1029. González-Fernández J, Rivas L, Luque-Ortega JR, et al. Recombinant vs native *Anisakis* haemoglobin (Ani s 13): Its appraisal as a new gold standard for the diagnosis of allergy. *Exp Parasitol*. 2017;181:119-129.
1030. de Las Vecillas L, Bartolomé-Zavala B, Asensio E, et al. Hypersensitivity to Chironomid Larvae in a Nonatopic Patient: Safe Diagnosis Tools to Identify a Potent Allergen. *J Investig Allergol Clin Immunol*. 2018;28(4):259-260.
1031. Radauer C, Bublín M, Wagner S, Mari A, Breiteneder H. Allergens are distributed into few protein families and possess a restricted number of biochemical functions. *J Allergy Clin Immunol*. 2008;121(4):847-852.e847.
1032. Moonesinghe H, Mackenzie H, Venter C, et al. Prevalence of fish and shellfish allergy: A systematic review. *Ann Allergy Asthma Immunol*. 2016;117(3):264-272.e264.
1033. Lyons SA, Clausen M, Knulst AC, et al. Prevalence of Food Sensitization and Food Allergy in Children Across Europe. *J Allergy Clin Immunol Pract*. 2020;8(8):2736-2746.e2739.
1034. Lyons SA, Burney PGJ, Ballmer-Weber BK, et al. Food Allergy in Adults: Substantial Variation in Prevalence and Causative Foods Across Europe. *J Allergy Clin Immunol Pract*. 2019;7(6):1920-1928.e1911.
1035. Xepapadaki P, Christopoulou G, Stavroulakis G, et al. Natural History of IgE-Mediated Fish Allergy in Children. *J Allergy Clin Immunol Pract*. 2021;9(8):3147-3156.e3145.
1036. Sørensen M, Kuehn A, Mills ENC, et al. Cross-reactivity in fish allergy: A double-blind, placebo-controlled food-challenge trial. *J Allergy Clin Immunol*. 2017;140(4):1170-1172.
1037. Kuehn A, Fischer J, Hilger C, Sparla C, Biedermann T, Hentges F. Correlation of clinical monosensitivity to cod with specific IgE to enolase and aldolase. *Ann Allergy Asthma Immunol*. 2014;113(6):670-671.e672.
1038. Brusca I, Graci S, Barrale M, et al. Use of a comprehensive diagnostic algorithm for *Anisakis* allergy in a high seroprevalence Mediterranean setting. *Eur Ann Allergy Clin Immunol*. 2020;52(3):131-141.
1039. de las Vecillas L, Muñoz-Cacho P, López-Hoyos M, et al. Analysis of Ani s 7 and Ani s 1 allergens as biomarkers of sensitization and allergy severity in human anisakiasis. *Sci Rep*. 2020;10(1):11275.
1040. Cuéllar C, Daschner A, Valls A, et al. Ani s 1 and Ani s 7 recombinant allergens are able to differentiate distinct *Anisakis* simplex-associated allergic clinical disorders. *Arch Dermatol Res*. 2012;304(4):283-288.
1041. Daschner A, Fernández-Figueras V, Rodero M, et al. Specific IgG4: possible role in the pathogenesis and a new marker in the diagnosis of *Anisakis*-associated allergic disease. *Scand J Immunol*. 2014;79(2):120-126.
1042. Sampson HA, Ho DG. Relationship between food-specific IgE concentrations and the risk of positive food challenges in children and adolescents. *J Allergy Clin Immunol*. 1997;100(4):444-451.
1043. Infante S, Pérez-Pallisé E, Skrabski F, et al. Poor prognosis of food protein-induced enterocolitis syndrome to fish. *Pediatr Allergy Immunol*. 2021;32(3):560-565.
1044. Mazzucco W, Raia DD, Marotta C, et al. *Anisakis* sensitisation in different population groups and public health impact: A systematic review. *PLoS One*. 2018;13(9):e0203671. Published 2018 Sep 20.
1045. Kuehn A, Codreanu-Morel F, Lehnert-Weber C, et al. Cross-reactivity to fish and chicken meat - a new clinical syndrome. *Allergy*. 2016;71(12):1772-1781.
1046. Turner P, Ng I, Kemp A, Campbell D. Seafood allergy in children: a descriptive study. *Ann Allergy Asthma Immunol*. 2011;106(6):494-501.
1047. Chokshi NY, Maskatia Z, Miller S, Guffey D, Minard CG, Davis CM. Risk factors in pediatric shrimp allergy. *Allergy Asthma Proc*. 2015;36(4):65-71.
1048. Kamath SD, Rahman AM, Voskamp A, et al. Effect of heat processing on antibody reactivity to allergen variants and fragments of black tiger prawn: A comprehensive allergenomic approach. *Mol Nutr Food Res*. 2014;58(5):1144-1155.
1049. Koeberl M, Clarke D, Lopata AL. Next generation of food allergen quantification using mass spectrometric systems. *J Proteome Res*. 2014;13(8):3499-3509.
1050. Kamath SD, Thomassen MR, Saptarshi SR, et al. Molecular and immunological approaches in quantifying the air-borne food allergen tropomyosin in crab processing facilities. *Int J Hyg Environ Health*. 2014;217(7):740-750.
1051. Baynova K, Leguísamo S, Bartolomé B, Prados M. Occupational allergic contact urticaria caused by the crustaceans *Palaemon*

- serratus and *Procambarus clarkii*. *Contact Dermatitis*. 2015;73(1):53-54.
1052. Lopata AL, Jeebhay MF. Airborne seafood allergens as a cause of occupational allergy and asthma. *Curr Allergy Asthma Rep*. 2013;13(3):288-297.
1053. Calleja Algarra A, Aragón Miguel R, Ortiz de Frutos FJ, Tous Romero F. Hand Lesions After Contact With Shellfish: Beyond Patch Testing. *Actas Dermosifiliogr (Engl Ed)*. 2021;112(3):274-275.
1054. Jeebhay MF, Moscato G, Bang BE, et al. Food processing and occupational respiratory allergy- An EAACI position paper. *Allergy*. 2019;74(10):1852-1871.
1055. Nieuwenhuizen NE, Lopata AL. Anisakis—a food-borne parasite that triggers allergic host defences. *Int J Parasitol*. 2013;43(12-13):1047-1057.
1056. Shanti KN, Martin BM, Nagpal S, Metcalfe DD, Rao PV. Identification of tropomyosin as the major shrimp allergen and characterization of its IgE-binding epitopes. *J Immunol*. 1993;151(10):5354-5363.
1057. Kamath SD, Scheibelhofer S, Johnson CM, et al. Effect of structural stability on endolysosomal degradation and T-cell reactivity of major shrimp allergen tropomyosin. *Allergy*. 2020;75(11):2909-2919.
1058. Guillen D, Fiandor A, Del Pozo V, et al. Anaphylaxis caused by hemocyanin contained in shrimp cephalothorax. *Ann Allergy Asthma Immunol*. 2014;113(6):674-675.e672.
1059. Yang S, Huang H, Wang F, Aweya JJ, Zheng Z, Zhang Y. Prediction and characterization of a novel hemocyanin-derived antimicrobial peptide from shrimp *Litopenaeus vannamei*. *Amino Acids*. 2018;50(8):995-1005.
1060. Mendoza-Porrás O, Kamath S, Harris JO, et al. Resolving hemocyanin isoform complexity in haemolymph of black tiger shrimp *Penaeus monodon* - implications in aquaculture, medicine and food safety. *J Proteomics*. 2020;218:103689.
1061. Nugraha R, Kamath SD, Johnston E, et al. Rapid and comprehensive discovery of unreported shellfish allergens using large-scale transcriptomic and proteomic resources. *J Allergy Clin Immunol*. 2018;141(4):1501-1504.e1508.
1062. Rona RJ, Keil T, Summers C, et al. The prevalence of food allergy: a meta-analysis. *J Allergy Clin Immunol*. 2007;120(3):638-646.
1063. Wang HT, Warren CM, Gupta RS, Davis CM. Prevalence and Characteristics of Shellfish Allergy in the Pediatric Population of the United States. *J Allergy Clin Immunol Pract*. 2020;8(4):1359-1370.e1352.
1064. Gámez C, Sánchez-García S, Ibáñez MD, et al. Tropomyosin IgE-positive results are a good predictor of shrimp allergy. *Allergy*. 2011;66(10):1375-1383.
1065. Yang AC, Arruda LK, Santos AB, et al. Measurement of IgE antibodies to shrimp tropomyosin is superior to skin prick testing with commercial extract and measurement of IgE to shrimp for predicting clinically relevant allergic reactions after shrimp ingestion. *J Allergy Clin Immunol*. 2010;125(4):872-878.
1066. Pascal MKS, Faber M. Diagnosis and management of shellfish allergy: current approach and future needs. *Curr Treat Options Allergy*. 2018;1-17. doi:10.1007/s40521-018-0186-0
1067. Wai CY, Leung NYH, Leung ASY, Wong GWK, Leung TF. Seafood Allergy in Asia: Geographical Specificity and Beyond. *Front Allergy*. 2021;2:676903.
1068. Abramovitch JB, Kamath S, Varese N, et al. IgE Reactivity of Blue Swimmer Crab (*Portunus pelagicus*) Tropomyosin, Por p 1, and Other Allergens; Cross-Reactivity with Black Tiger Prawn and Effects of Heating. *PLoS One*. 2013;8(6):e67487.
1069. Vidal C, Bartolomé B, Rodríguez V, Armisen M, Linneberg A, González-Quintela A. Sensitization pattern of crustacean-allergic individuals can indicate allergy to molluscs. *Allergy*. 2015;70(11):1493-1496.
1070. Giuffrida MG, Villalta D, Mistrello G, Amato S, Asero R. Shrimp allergy beyond Tropomyosin in Italy: clinical relevance of Arginine Kinase, Sarcoplasmic calcium binding protein and Hemocyanin. *Eur Ann Allergy Clin Immunol*. 2014;46(5):172-177.
1071. Thomassen MR, Kamath SD, Bang BE, et al. Occupational Allergic Sensitization Among Workers Processing King Crab (*Paralithodes camtschaticus*) and Edible Crab (*Cancer pagurus*) in Norway and Identification of Novel Putative Allergenic Proteins. *Front Allergy*. 2021;2:718824.
1072. Cox AL, Eigenmann PA, Sicherer SH. Clinical Relevance of Cross-Reactivity in Food Allergy. *J Allergy Clin Immunol Pract*. 2021;9(1):82-99.
1073. Wang J, Calatroni A, Visness CM, Sampson HA. Correlation of specific IgE to shrimp with cockroach and dust mite exposure and sensitization in an inner-city population. *J Allergy Clin Immunol*. 2011;128(4):834-837.
1074. Nowak-Węgrzyn A, Berin MC, Mehr S. Food Protein-Induced Enterocolitis Syndrome. *J Allergy Clin Immunol Pract*. 2020;8(1):24-35.
1075. Asaumi T, Yanagida N, Sato S, Shukuya A, Nishino M, Ebisawa M. Provocation tests for the diagnosis of food-dependent exercise-induced anaphylaxis. *Pediatr Allergy Immunol*. 2016;27(1):44-49.
1076. Caubet JC, Cianferoni A, Groetch M, Nowak-Węgrzyn A. Food protein-induced enterocolitis syndrome. *Clin Exp Allergy*. 2019;49(9):1178-1190.
1077. Warren CM, Aktas ON, Gupta RS, Davis CM. Prevalence and characteristics of adult shellfish allergy in the United States. *J Allergy Clin Immunol*. 2019;144(5):1435-1438.e1435.
1078. Morgan JE, O'Neil CE, Daul CB, Lehrer SB. Species-specific shrimp allergens: RAST and RAST-inhibition studies. *J Allergy Clin Immunol*. 1989;83(6):1112-1117.
1079. Jirapongsananuruk O, Sripramong C, Pacharn P, et al. Specific allergy to *Penaeus monodon* (seawater shrimp) or *Macrobrachium rosenbergii* (freshwater shrimp) in shrimp-allergic children. *Clin Exp Allergy*. 2008;38(6):1038-1047.
1080. Liu GY, Mei XJ, Hu MJ, et al. Analysis of the Allergenic Epitopes of Tropomyosin from Mud Crab Using Phage Display and Site-Directed Mutagenesis. *J Agric Food Chem*. 2018;66(34):9127-9137.
1081. Wong L, Tham EH, Lee BW. An update on shellfish allergy. *Curr Opin Allergy Clin Immunol*. 2019;19(3):236-242.
1082. Nugraha R, Kamath SD, Johnston E, Karnaneedi S, Ruethers T, Lopata AL. Conservation Analysis of B-Cell Allergen Epitopes to Predict Clinical Cross-Reactivity Between Shellfish and Inhaled Invertebrate Allergens. *Front Immunol*. 2019;10:2676.
1083. Ayuso R, Lehrer SB, Lopez M, et al. Identification of bovine IgG as a major cross-reactive vertebrate meat allergen. *Allergy*. 2000;55(4):348-354.
1084. Mahdavinia M, Tobin MC, Fierstein JL, et al. African American Children Are More Likely to Be Allergic to Shellfish and Finfish: Findings from FORWARD, a Multisite Cohort Study. *J Allergy Clin Immunol Pract*. 2021;9(7):2867-2873.e2861.
1085. Ayuso RS-GS, Lin J, et al. Greater epitope recognition of shrimp allergens by children than by adults suggests that shrimp sensitization decreases with age. *J Allergy Clin Immunol*. 2010;125(6):1286-1293.e3. doi:10.1016/j.jaci.2010.03.010
1086. Thalayasingam M, Gerezi IF, Yap GC, et al. Clinical and immunochemical profiles of food challenge proven or anaphylactic shrimp allergy in tropical Singapore. *Clin Exp Allergy*. 2015;45(3):687-697.
1087. Teo SL, Gerezi IF, Ang EY, Shek LP. Food-dependent exercise-induced anaphylaxis - a review of 5 cases. *Ann Acad Med Singapore*. 2009;38(10):905-909.
1088. Kandyil RM, Davis CM. Shellfish allergy in children. *Pediatr Allergy Immunol*. 2009;20(5):408-414. quiz 414.
1089. Fiocchi A, Restani P, Riva E. Beef allergy in children. *Nutrition*. 2000;16(6):454-457.

1090. Restani P, Fiocchi A, Beretta B, Velonà T, Giovannini M, Galli CL. Meat allergy: III-Proteins involved and cross-reactivity between different animal species. *J Am Coll Nutr*. 1997;16(4):383-389.
1091. Chandra RK, Puri S, Suraiya C, Cheema PS. Influence of maternal food antigen avoidance during pregnancy and lactation on incidence of atopic eczema in infants. *Clin Allergy*. 1986;16(6):563-569.
1092. Spitzauer S. Allergy to mammalian proteins: at the borderline between foreign and self? *Int Arch Allergy Immunol*. 1999;120(4):259-269.
1093. Posthumus J, James HR, Lane CJ, Matos LA, Platts-Mills TA, Commins SP. Initial description of pork-cat syndrome in the United States. *J Allergy Clin Immunol*. 2013;131(3):923-925.
1094. Chung CH, Mirakhor B, Chan E, et al. Cetuximab-induced anaphylaxis and IgE specific for galactose- α -1,3-galactose. *N Engl J Med*. 2008;358(11):1109-1117.
1095. Takahashi H, Chinuki Y, Tanaka A, Morita E. Laminin γ -1 and collagen α -1 (VI) chain are galactose- α -1,3-galactose-bound allergens in beef. *Allergy*. 2014;69(2):199-207.
1096. Fischer J, Hebsaker J, Caponetto P, Platts-Mills TA, Biedermann T. Galactose- α -1,3-galactose sensitization is a prerequisite for pork-kidney allergy and cofactor-related mammalian meat anaphylaxis. *J Allergy Clin Immunol*. 2014;134(3):755-759.e751.
1097. Mullins RJ, James H, Platts-Mills TA, Commins S. Relationship between red meat allergy and sensitization to gelatin and galactose- α -1,3-galactose. *J Allergy Clin Immunol*. 2012;129(5):1334-1342.e1331.
1098. Grönlund H, Adéyoyin J, Commins SP, Platts-Mills TA, van Hage M. The carbohydrate galactose- α -1,3-galactose is a major IgE-binding epitope on cat IgA. *J Allergy Clin Immunol*. 2009;123:1189-1191.
1099. Hilger C, Fischer J, Wölbinger F, Biedermann T. Role and Mechanism of Galactose- α -1,3-Galactose in the Elicitation of Delayed Anaphylactic Reactions to Red Meat. *Curr Allergy Asthma Rep*. 2019;19(1):3.
1100. Platts-Mills TAECS, Biedermann T, et al. On the cause and consequences of IgE to galactose- α -1,3-galactose: A report from the National Institute of Allergy and Infectious Diseases Workshop on Understanding IgE-Mediated Mammalian Meat Allergy. *J Allergy Clin Immunol*. 2020;145(4):1061-1071. doi:10.1016/j.jaci.2020.01.047
1101. Apostolovic D, Tran TA, Starkhammar M, Sánchez-Vidaurre S, Hamsten C, Van Hage M. The red meat allergy syndrome in Sweden. *Allergo J Int*. 2016;25(2):49-54.
1102. Mabelane T, Basera W, Botha M, Thomas HF, Ramjith J, Levin ME. Predictive values of alpha-gal IgE levels and alpha-gal IgE: Total IgE ratio and oral food challenge-proven meat allergy in a population with a high prevalence of reported red meat allergy. *Pediatr Allergy Immunol*. 2018;29(8):841-849.
1103. Wilson JM, Schuyler AJ, Workman L, et al. Investigation into the α -Gal Syndrome: Characteristics of 261 Children and Adults Reporting Red Meat Allergy. *J Allergy Clin Immunol Pract*. 2019;7(7):2348-2358.e2344.
1104. Kiewiet MBG, Apostolovic D, Starkhammar M, Grundström J, Hamsten C, van Hage M. Clinical and Serological Characterization of the α -Gal Syndrome-Importance of Atopy for Symptom Severity in a European Cohort. *J Allergy Clin Immunol Pract*. 2020;8(6):2027-2034.e2022.
1105. Hamsten C, Starkhammar M, Tran TA, et al. Identification of galactose- α -1,3-galactose in the gastrointestinal tract of the tick *Ixodes ricinus*; possible relationship with red meat allergy. *Allergy*. 2013;68(4):549-552.
1106. Fischer J, Riel S, Fehrenbacher B, et al. Spatial distribution of alpha-gal in *Ixodes ricinus* - A histological study. *Ticks Tick Borne Dis*. 2020;11(5):101506.
1107. Mateos-Hernández L, Villar M, Moral A, et al. Tick-host conflict: immunoglobulin E antibodies to tick proteins in patients with anaphylaxis to tick bite. *Oncotarget*. 2017;8(13):20630-20644.
1108. Apostolovic D, Mihailovic J, Commins SP, et al. Allergenomics of the tick *Ixodes ricinus* reveals important α -Gal-carrying IgE-binding proteins in red meat allergy. *Allergy*. 2020;75(1):217-220.
1109. Commins SP, James HR, Kelly LA, et al. The relevance of tick bites to the production of IgE antibodies to the mammalian oligosaccharide galactose- α -1,3-galactose. *J Allergy Clin Immunol*. 2011;127(5):1286-1293.e1286.
1110. Stoltz LPCL, Dowling APG, et al. Could chiggers be contributing to the prevalence of galactose- α -1,3-galactose sensitization and mammalian meat allergy? *J Allergy Clin Immunol Pract*. 2019;7(2):664-666. doi:10.1016/j.jaip.2018.07.014
1111. Van Nunen SA, O'Connor KS, Clarke LR, Boyle RX, Fernando SL. An association between tick bite reactions and red meat allergy in humans. *Med J Aust*. 2009;190(9):510-511.
1112. Hamsten C, Tran TAT, Starkhammar M, et al. Red meat allergy in Sweden: association with tick sensitization and B-negative blood groups. *J Allergy Clin Immunol*. 2013;132:1431-1434.
1113. Jappe U, Minge S, Kreft B, et al. Meat allergy associated with galactosyl- α -(1,3)-galactose (α -Gal)-Closing diagnostic gaps by anti- α -Gal IgE immune profiling. *Allergy*. 2018;73(1):93-105.
1114. Kiewiet MBG, Grundström J, Apostolovic D, et al. Elucidating the α -Gal syndrome at the molecular allergen level. *Allergy*. 2021;76:1576-1578.
1115. Apostolovic D, Rodrigues R, Thomas P, Starkhammar M, Hamsten C, van Hage M. Immunoprofile of α -Gal- and B-antigen-specific responses differentiates red meat-allergic patients from healthy individuals. *Allergy*. 2018;73(7):1525-1531.
1116. Wilson JM, Nguyen AT, Schuyler AJ, et al. IgE to the Mammalian Oligosaccharide Galactose- α -1,3-Galactose Is Associated With Increased Atheroma Volume and Plaques With Unstable Characteristics-Brief Report. *Arterioscler Thromb Vasc Biol*. 2018;38(7):1665-1669.
1117. Anemüller WMM, Brans R, et al. Alpha-Gal-assoziierte verzögerte Anaphylaxie gegen rotes Fleisch als Berufskrankheit [Alpha-Gal-associated delayed red meat anaphylaxis as an occupational disease]. *Hautarzt*. 2018;69(10):848-852. doi:10.1007/s00105-018-4224-4
1118. Perusko M, Apostolovic D, Kiewiet MBG, et al. Bovine γ -globulin, lactoferrin, and lactoperoxidase are relevant bovine milk allergens in patients with α -Gal syndrome. *Allergy*. 2021;76(12):3766-3775.
1119. Swiontek K, Morisset M, Codreanu-Morel F, et al. Drugs of porcine origin-A risk for patients with α -gal syndrome? *J Allergy Clin Immunol Pract*. 2019;7(5):1687-1690.e1683.
1120. Hashizume H, Fujiyama T, Umayahara T, Kageyama R, Walls AF, Satoh T. Repeated *Amblyomma testudinarium* tick bites are associated with increased galactose- α -1,3-galactose carbohydrate IgE antibody levels: A retrospective cohort study in a single institution. *J Am Acad Dermatol*. 2018;78(6):1135-1141.e1133.
1121. Kim MS, Straesser MD, Keshavarz B, et al. IgE to galactose- α -1,3-galactose wanes over time in patients who avoid tick bites. *J Allergy Clin Immunol Pract*. 2020;8(1):364-367.e362.
1122. Bolhaar ST, van de Weg WE, van Ree R, et al. *In vivo* assessment with prick-to-prick testing and double-blind, placebo-controlled food challenge of allergenicity of apple cultivars. *J Allergy Clin Immunol*. 2005;116(5):1080-1086.
1123. Sancho AI, van Ree R, van Leeuwen A, et al. Measurement of lipid transfer protein in 88 apple cultivars. *Int Arch Allergy Immunol*. 2008;146(1):19-26.
1124. Sancho AIFR, Browne T, et al. Effect of postharvest storage on the expression of the apple allergen Mal d 1. *J Agric Food Chem*. 2006;54(16):5917-5923. doi:10.1021/jf060880m
1125. Bässler OY, Weiss J, Wienkoop S, et al. Evidence for novel tomato seed allergens: IgE-reactive legumin and vicilin proteins identified by multidimensional protein fractionation-mass spectrometry and in silico epitope modeling. *J Proteome Res*. 2009;8(3):1111-1122.

1126. Kschonsek J, Wiegand C, Hipler UC, Böhm V. Influence of polyphenolic content on the *in vitro* allergenicity of old and new apple cultivars: A pilot study. *Nutrition*. 2019;58:30-35.
1127. Gaier S, Marsh J, Oberhuber C, et al. Purification and structural stability of the peach allergens Pru p 1 and Pru p 3. *Mol Nutr Food Res*. 2008;52(Suppl 2):S220-S229.
1128. Bogas G, Muñoz-Cano R, Mayorga C, et al. Phenotyping peach-allergic patients sensitized to lipid transfer protein and analysing severity biomarkers. *Allergy*. 2020;75(12):3228-3236.
1129. Fernández-Rivas M, González-Mancebo E, Rodríguez-Pérez R, et al. Clinically relevant peach allergy is related to peach lipid transfer protein, Pru p 3, in the Spanish population. *J Allergy Clin Immunol*. 2003;112(4):789-795.
1130. Inomata N. Gibberellin-regulated protein allergy: Clinical features and cross-reactivity. *Allergol Int*. 2020;69(1):11-18.
1131. Karamloo F, Wangorsch A, Kasahara H, et al. Phenylcoumaran benzylic ether and isoflavonoid reductases are a new class of cross-reactive allergens in birch pollen, fruits and vegetables. *Eur J Biochem*. 2001;268(20):5310-5320.
1132. Sirvent S, Cantó B, Gómez F, et al. Detailed characterization of Act d 12 and Act d 13 from kiwi seeds: implication in IgE cross-reactivity with peanut and tree nuts. *Allergy*. 2014;69(11):1481-1488.
1133. Bublin M, Mari A, Ebner C, et al. IgE sensitization profiles toward green and gold kiwifruits differ among patients allergic to kiwifruit from 3 European countries. *J Allergy Clin Immunol*. 2004;114(5):1169-1175.
1134. Le TM, Fritsche P, Bublin M, et al. Differences in the allergenicity of 6 different kiwifruit cultivars analyzed by prick-to-prick testing, open food challenges, and ELISA. *J Allergy Clin Immunol*. 2011;127:677-679.
1135. Asero R, Mistrello G, Roncarolo D, et al. Detection of clinical markers of sensitization to profilin in patients allergic to plant-derived foods. *J Allergy Clin Immunol*. 2003;112(2):427-432.
1136. Sankian M, Varasteh A, Pazouki N, Mahmoudi M. Sequence homology: a poor predictive value for profilins cross-reactivity. *Clin Mol Allergy*. 2005;3:13.
1137. Cuesta-Herranz J, Pastor C, Figueredo E, et al. Identification of Cucumis (Cuc m 1), a subtilisin-like endopeptidase, as the major allergen of melon fruit. *Clin Exp Allergy*. 2003;33(6):827-833.
1138. Asensio T, Crespo JF, Sanchez-Monge R, et al. Novel plant pathogenesis-related protein family involved in food allergy. *J Allergy Clin Immunol*. 2004;114(4):896-899.
1139. Sarkar MB, Sircar G, Ghosh N, et al. Cari p 1, a Novel Polygalacturonase Allergen From Papaya Acting as Respiratory and Food Sensitizer. *Front Plant Sci*. 2018;9:823.
1140. Bhowmik M, Biswas Sarkar M, Kanti Sarkar R, et al. Cloning and immunobiochemical analyses on recombinant chymopapain allergen Cari p 2 showing pollen-fruit cross-reaction. *Mol Immunol*. 2021;137:42-51.
1141. Bublin M, Radauer C, Wilson IB, et al. Cross-reactive N-glycans of Api g 5, a high molecular weight glycoprotein allergen from celery, are required for immunoglobulin E binding and activation of effector cells from allergic patients. *FASEB J*. 2003;17(12):1697-1699.
1142. Gadermaier G, Hauser M, Egger M, et al. Sensitization prevalence, antibody cross-reactivity and immunogenic peptide profile of Api g 2, the non-specific lipid transfer protein 1 of celery. *PLoS One*. 2011;6(8):e24150.
1143. Vejvar E, Himly M, Briza P, et al. Allergenic relevance of non-specific lipid transfer proteins 2: Identification and characterization of Api g 6 from celery tuber as representative of a novel IgE-binding protein family. *Mol Nutr Food Res*. 2013;57(11):2061-2070.
1144. Wangorsch A, Lidholm J, Mattsson LA, et al. Identification of a defensin as novel allergen in celery root: Api g 7 as a missing link in the diagnosis of celery allergy? *Allergy*. 2022;77(4):1294-1296.
1145. Zuidmeer L, Goldhahn K, Rona RJ, et al. The prevalence of plant food allergies: a systematic review. *J Allergy Clin Immunol*. 2008;121(5):1210-1218.e1214.
1146. Burney PG, Potts J, Kummeling I, et al. The prevalence and distribution of food sensitization in European adults. *Allergy*. 2014;69(3):365-371.
1147. Boyano-Martínez T, Pedrosa M, Belver T, Quirce S, García-Ara C. Peach allergy in Spanish children: tolerance to the pulp and molecular sensitization profile. *Pediatr Allergy Immunol*. 2013;24(2):168-172.
1148. Pastorello EA, Farioli L, Stafylaraki C, et al. Anti-rPru p 3 IgE levels are inversely related to the age at onset of peach-induced severe symptoms reported by peach-allergic adults. *Int Arch Allergy Immunol*. 2013;162(1):45-49.
1149. Le TM, Bublin M, Breiteneder H, et al. Kiwifruit allergy across Europe: clinical manifestation and IgE recognition patterns to kiwifruit allergens. *J Allergy Clin Immunol*. 2013;131(1):164-171.
1150. Bublin M, Pfister M, Radauer C, et al. Component-resolved diagnosis of kiwifruit allergy with purified natural and recombinant kiwifruit allergens. *J Allergy Clin Immunol*. 2010;125(3):687-694. 694.e681.
1151. Burney P, Summers C, Chinn S, Hooper R, van Ree R, Lidholm J. Prevalence and distribution of sensitization to foods in the European Community Respiratory Health Survey: a EuroPrevall analysis. *Allergy*. 2010;65(9):1182-1188.
1152. Bauermeister K, Ballmer-Weber BK, Bublin M, et al. Assessment of component-resolved *in vitro* diagnosis of celeriac allergy. *J Allergy Clin Immunol*. 2009;124(6):1273-1281.e1272.
1153. Ballmer-Weber BK, Skamstrup Hansen K, Sastre J, et al. Component-resolved *in vitro* diagnosis of carrot allergy in three different regions of Europe. *Allergy*. 2012;67(6):758-766.
1154. Ballmer-Weber BK, Hoffmann-Sommergruber K. Molecular diagnosis of fruit and vegetable allergy. *Curr Opin Allergy Clin Immunol*. 2011;11(3):229-235.
1155. Vera-Berrios RN, Freundt-Serpa NP, Fernández-Rivas M. Medical algorithm: Diagnosis of plant food allergy. *Allergy*. 2022;77(2):698-704.
1156. Ballmer-Weber BK, Scheurer S, Fritsche P, et al. Component-resolved diagnosis with recombinant allergens in patients with cherry allergy. *J Allergy Clin Immunol*. 2002;110(1):167-173.
1157. Ehrenberg AE, Klingebiel C, Östling J, et al. Characterization of a 7 kDa pollen allergen belonging to the gibberellin-regulated protein family from three Cupressaceae species. *Clin Exp Allergy*. 2020;50(8):964-972.
1158. Lidholm J, Ballmer-Weber BK, Mari A, Vieths S. Component-resolved diagnostics in food allergy. *Curr Opin Allergy Clin Immunol*. 2006;6(3):234-240.
1159. González-Mancebo E, González-de-Olano D, Trujillo MJ, et al. Prevalence of sensitization to lipid transfer proteins and profilins in a population of 430 patients in the south of Madrid. *J Investig Allergol Clin Immunol*. 2011;21(4):278-282.
1160. Le TM, van Hoffen E, Lebens AF, Bruijnzeel-Koomen CA, Knulst AC. Anaphylactic versus mild reactions to hazelnut and apple in a birch-endemic area: different sensitization profiles? *Int Arch Allergy Immunol*. 2013;160(1):56-62.
1161. Schulten V, Lauer I, Scheurer S, Thalhammer T, Bohle B. A food matrix reduces digestion and absorption of food allergens *in vivo*. *Mol Nutr Food Res*. 2011;55(10):1484-1491.
1162. Romano A, Scala E, Rumi G, et al. Lipid transfer proteins: the most frequent sensitizer in Italian subjects with food-dependent exercise-induced anaphylaxis. *Clin Exp Allergy*. 2012;42(11):1643-1653.
1163. Oberhuber C, Bulley SM, Ballmer-Weber BK, et al. Characterization of Bet v 1-related allergens from kiwifruit relevant for patients with combined kiwifruit and birch pollen allergy. *Mol Nutr Food Res*. 2008;52(Suppl 2):S230-S240.

1164. Palacin A, Rodriguez J, Blanco C, et al. Immunoglobulin E recognition patterns to purified Kiwifruit (*Actinidia deliciosa*) allergens in patients sensitized to Kiwi with different clinical symptoms. *Clin Exp Allergy*. 2008;38(7):1220-1228.
1165. Ballmer-Weber BK, Vieths S, Lüttkopf D, Heuschmann P, Wüthrich B. Celery allergy confirmed by double-blind, placebo-controlled food challenge: a clinical study in 32 subjects with a history of adverse reactions to celery root. *J Allergy Clin Immunol*. 2000;106(2):373-378.
1166. Ballmer-Weber BK, Hoffmann A, Wüthrich B, et al. Influence of food processing on the allergenicity of celery: DBPCFC with celery spice and cooked celery in patients with celery allergy. *Allergy*. 2002;57(3):228-235.
1167. Brehler R, Theissen U, Mohr C, Luger T. "Latex-fruit syndrome": frequency of cross-reacting IgE antibodies. *Allergy*. 1997;52(4):404-410.
1168. Garcia Ortiz JC, Moyano JC, Alvarez M, Bellido J. Latex allergy in fruit-allergic patients. *Allergy*. 1998;53(5):532-536.
1169. Radauer C, Adhami F, Fürtler I, et al. Latex-allergic patients sensitized to the major allergen hevein and hevein-like domains of class I chitinases show no increased frequency of latex-associated plant food allergy. *Mol Immunol*. 2011;48(4):600-609.
1170. Decuyper II, Van Gasse AL, Faber MA, et al. Exploring the Diagnosis and Profile of Cannabis Allergy. *J Allergy Clin Immunol Pract*. 2019;7(3):983-989.e985.
1171. Alkhamash S, Tsui H, Thomson DMP. Cannabis and hemp seed allergy. *J Allergy Clin Immunol Pract*. 2019;7(7):2429-2430.e2421.
1172. Decuyper II, Armentia A, Martín-Armentia B, Almuzara AC, Ebo DG, Brucker HA. Adverse Reactions to Illicit Drugs (Marijuana, Opioids, Cocaine) and Alcohol. *J Allergy Clin Immunol Pract*. 2021;9(8):3006-3014.
1173. Decuyper II, Green BJ, Sussman GL, et al. Occupational Allergies to Cannabis. *J Allergy Clin Immunol Pract*. 2020;8(10):3331-3338.
1174. Gamboa P, Sanchez-Monge R, Sanz ML, Palacin A, Salcedo G, Diaz-Perales A. Sensitization to *Cannabis sativa* caused by a novel allergenic lipid transfer protein, Can s 3. *J Allergy Clin Immunol*. 2007;120:1459-1460.
1175. Ebo DG, Decuyper II, Rihs HP, et al. IgE-binding and mast cell-activating capacity of the homologue of the major birch pollen allergen and profilin from *Cannabis sativa*. *J Allergy Clin Immunol Pract*. 2021;9(6):2509-2512.e2503.
1176. Decuyper II, Rihs HP, Mertens CH, et al. A new cannabis allergen in Northwestern Europe: The oxygen-evolving enhancer protein 2 (OEEP2). *J Allergy Clin Immunol Pract*. 2020;8(7):2421-2424.e2422.
1177. Bolhaar ST, Tiemessen MM, Zuidmeer L, et al. Efficacy of birch-pollen immunotherapy on cross-reactive food allergy confirmed by skin tests and double-blind food challenges. *Clin Exp Allergy*. 2004;34(5):761-769.
1178. Hansen KS, Khinchi MS, Skov PS, Bindslev-Jensen C, Poulsen LK, Malling HJ. Food allergy to apple and specific immunotherapy with birch pollen. *Mol Nutr Food Res*. 2004;48(6):441-448.
1179. Gevaert P, De Craemer J, De Ruyck N, et al. Novel antibody cocktail targeting Bet v 1 rapidly and sustainably treats birch allergy symptoms in a phase 1 study. *J Allergy Clin Immunol*. 2022;149(1):189-199.
1180. Kopac P, Rudin M, Gentinetta T, et al. Continuous apple consumption induces oral tolerance in birch-pollen-associated apple allergy. *Allergy*. 2012;67(2):280-285.
1181. Gomez F, Bogas G, Gonzalez M, et al. The clinical and immunological effects of Pru p 3 sublingual immunotherapy on peach and peanut allergy in patients with systemic reactions. *Clin Exp Allergy*. 2017;47(3):339-350.
1182. Sapone A, Bai JC, Ciacci C, et al. Spectrum of gluten-related disorders: consensus on new nomenclature and classification. *BMC Med*. 2012;10:13.
1183. Longo G, Berti I, Burks AW, Krauss B, Barbi E. IgE-mediated food allergy in children. *Lancet*. 2013;382(9905):1656-1664.
1184. Ostblom E, Lilja G, Pershagen G, van Hage M, Wickman M. Phenotypes of food hypersensitivity and development of allergic diseases during the first 8 years of life. *Clin Exp Allergy*. 2008;38(8):1325-1332.
1185. Constantin C, Quirce S, Poorafshar M, et al. Micro-arrayed wheat seed and grass pollen allergens for component-resolved diagnosis. *Allergy*. 2009;64(7):1030-1037.
1186. Mäkelä MJ, Eriksson C, Kotaniemi-Syrjänen A, et al. Wheat allergy in children - new tools for diagnostics. *Clin Exp Allergy*. 2014;44(11):1420-1430.
1187. Venter C, Pereira B, Grundy J, Clayton CB, Arshad SH, Dean T. Prevalence of sensitization reported and objectively assessed food hypersensitivity amongst six-year-old children: a population-based study. *Pediatr Allergy Immunol*. 2006;17(5):356-363.
1188. Burman J, Palosuo K, Kukkonen K, Pelkonen A, Mäkelä MJ. Children with wheat allergy usually tolerate oats. *Pediatr Allergy Immunol*. 2019;30(8):855-857.
1189. Palosuo K, Alenius H, Varjonen E, Kalkkinen N, Reunala T. Rye gamma-70 and gamma-35 secalins and barley gamma-3 hordein cross-react with omega-5 gliadin, a major allergen in wheat-dependent, exercise-induced anaphylaxis. *Clin Exp Allergy*. 2001;31(3):466-473.
1190. Pahr S, Constantin C, Papadopoulos NG, et al. α -Purothionin, a new wheat allergen associated with severe allergy. *J Allergy Clin Immunol*. 2013;132(4):1000-1003.e1001-1004.
1191. Sander I, Rihs HP, Doekes G, et al. Component-resolved diagnosis of baker's allergy based on specific IgE to recombinant wheat flour proteins. *J Allergy Clin Immunol*. 2015;135(6):1529-1537.
1192. Palosuo K, Varjonen E, Kekki OM, et al. Wheat omega-5 gliadin is a major allergen in children with immediate allergy to ingested wheat. *J Allergy Clin Immunol*. 2001;108(4):634-638.
1193. Ito K, Futamura M, Borres MP, et al. IgE antibodies to omega-5 gliadin associate with immediate symptoms on oral wheat challenge in Japanese children. *Allergy*. 2008;63(11):1536-1542.
1194. Nilsson N, Sjölander S, Baar A, et al. Wheat allergy in children evaluated with challenge and IgE antibodies to wheat components. *Pediatr Allergy Immunol*. 2015;26(2):119-125.
1195. Palacin A, Quirce S, Armentia A, et al. Wheat lipid transfer protein is a major allergen associated with baker's asthma. *J Allergy Clin Immunol*. 2007;120(5):1132-1138.
1196. Pastorello EA, Farioli L, Conti A, et al. Wheat IgE-mediated food allergy in European patients: alpha-amylase inhibitors, lipid transfer proteins and low-molecular-weight glutenins. Allergenic molecules recognized by double-blind, placebo-controlled food challenge. *Int Arch Allergy Immunol*. 2007;144(1):10-22.
1197. Scibilia J, Pastorello EA, Zisa G, et al. Wheat allergy: a double-blind, placebo-controlled study in adults. *J Allergy Clin Immunol*. 2006;117(2):433-439.
1198. Brockow K, Kneissl D, Valentini L, et al. Using a gluten oral food challenge protocol to improve diagnosis of wheat-dependent exercise-induced anaphylaxis. *J Allergy Clin Immunol*. 2015;135(4):977-984.e974.
1199. Tomsitz D, Biedermann T, Brockow K. Sublingual immunotherapy reduces reaction threshold in three patients with wheat-dependent exercise-induced anaphylaxis. *Allergy*. 2021;76(12):3804-3806.
1200. Kotaniemi-Syrjänen A, Palosuo K, Jarhti T, Kuitunen M, Pelkonen AS, Mäkelä MJ. The prognosis of wheat hypersensitivity in children. *Pediatr Allergy Immunol*. 2010;21(2 Pt 2):e421-e428.
1201. Koike Y, Yanagida N, Sato S, et al. Predictors of Persistent Wheat Allergy in Children: A Retrospective Cohort Study. *Int Arch Allergy Immunol*. 2018;176(3-4):249-254.
1202. Giménez-Bastida JA, Zieliński H. Buckwheat as a Functional Food and Its Effects on Health. *J Agric Food Chem*. 2015;63(36):7896-7913.
1203. Heffler E, Nebiolo F, Asero R, et al. Clinical manifestations, co-sensitizations, and immunoblotting profiles of buckwheat-allergic patients. *Allergy*. 2011;66(2):264-270.

1204. Norbäck D, Wieslander G. A Review on Epidemiological and Clinical Studies on Buckwheat Allergy. *Plants (Basel)*. 2021;10(3).
1205. Jungewelter S, Airaksinen L, Pesonen M. Occupational buckwheat allergy as a cause of allergic rhinitis, asthma, contact urticaria and anaphylaxis-An emerging problem in food-handling occupations? *Am J Ind Med*. 2020;63(11):1047-1053.
1206. Breiteneder H, Radauer C. A classification of plant food allergens. *J Allergy Clin Immunol*. 2004;113(5):821-830. quiz 831.
1207. Maruyama N, Sato S, Yanagida N, et al. Clinical utility of recombinant allergen components in diagnosing buckwheat allergy. *J Allergy Clin Immunol Pract*. 2016;4(2):322-323.e323.
1208. Imamura T, Kanagawa Y, Ebisawa M. A survey of patients with self-reported severe food allergies in Japan. *Pediatr Allergy Immunol*. 2008;19(3):270-274.
1209. Yanagida N, Sato S, Takahashi K, et al. Reactions of Buckwheat-Hypersensitive Patients during Oral Food Challenge Are Rare, but Often Anaphylactic. *Int Arch Allergy Immunol*. 2017;172(2):116-122.
1210. Badiu I, Olivieri E, Montagni M, et al. Italian study on buckwheat allergy: prevalence and clinical features of buckwheat-sensitized patients in Italy. *Int J Immunopathol Pharmacol*. 2013;26:801-806.
1211. Urisu AKY, Morita Y, et al. Identification of a major allergen of buckwheat seeds by immunoblotting methods. *Allergy Clin Immunol News*. 1994;6:151-155. doi:10.1034/j.1398-9995.2000.00763.x
1212. Geiselhart S, Nagl C, Dubiela P, et al. Concomitant sensitization to legumin, Fag e 2 and Fag e 5 predicts buckwheat allergy. *Clin Exp Allergy*. 2018;48(2):217-224.
1213. Tanaka K, Matsumoto K, Akasawa A, et al. Pepsin-resistant 16-kD buckwheat protein is associated with immediate hypersensitivity reaction in patients with buckwheat allergy. *Int Arch Allergy Immunol*. 2002;129(1):49-56.
1214. Tohgi K, Kohno K, Takahashi H, Matsuo H, Nakayama S, Morita E. Usability of Fag e 2 ImmunoCAP in the diagnosis of buckwheat allergy. *Arch Dermatol Res*. 2011;303(9):635-642.
1215. Fok JS, Kette F, Smith WB, et al. Buckwheat allergy in Australia. *Intern Med J*. 2019;49(12):1552-1553.
1216. L'Hocine L, Boye JI. Allergenicity of soybean: new developments in identification of allergenic proteins, cross-reactivities and hypoallergenization technologies. *Crit Rev Food Sci Nutr*. 2007;47(2):127-143.
1217. Besler M, Helm RM, Ogawa T. Allergen data collection - update: soybean (*Glycine max*). *Int Symp Food Allergy*. 2000;2:1-35.
1218. Mittag D, Vieths S, Vogel L, et al. Soybean allergy in patients allergic to birch pollen: clinical investigation and molecular characterization of allergens. *J Allergy Clin Immunol*. 2004;113(1):148-154.
1219. Ballmer-Weber BK, Vieths S. Soy allergy in perspective. *Curr Opin Allergy Clin Immunol*. 2008;8(3):270-275.
1220. Katz Y, Gutierrez-Castrellon P, Gonzalez MG, Rivas R, Lee BW, Alarcon P. A comprehensive review of sensitization and allergy to soy-based products. *Clin Rev Allergy Immunol*. 2014;46(3):272-281.
1221. Sato M, Shukuya A, Sato S, et al. Oral challenge tests for soybean allergies in Japan: A summary of 142 cases. *Allergol Int*. 2016;65(1):68-73.
1222. Kleine-Tebbe J, Vogel L, Crowell DN, Hausteil UF, Vieths S. Severe oral allergy syndrome and anaphylactic reactions caused by a Bet v 1-related PR-10 protein in soybean, SAM22. *J Allergy Clin Immunol*. 2002;110(5):797-804.
1223. Ballmer-Weber BK, Holzhauser T, Scibilia J, et al. Clinical characteristics of soybean allergy in Europe: a double-blind, placebo-controlled food challenge study. *J Allergy Clin Immunol*. 2007;119(6):1489-1496.
1224. Holzhauser T, Wackermann O, Ballmer-Weber BK, et al. Soybean (*Glycine max*) allergy in Europe: Gly m 5 (beta-conglycinin) and Gly m 6 (glycinin) are potential diagnostic markers for severe allergic reactions to soy. *J Allergy Clin Immunol*. 2009;123(2):452-458.
1225. Yagami A, Inaba Y, Kuno Y, et al. Two cases of pollen-food allergy syndrome to soy milk diagnosed by skin prick test, specific serum immunoglobulin E and microarray analysis. *J Dermatol*. 2009;36(1):50-55.
1226. Fukutomi Y, Sjolander S, Nakazawa T, et al. Clinical relevance of IgE to recombinant Gly m 4 in the diagnosis of adult soybean allergy. *J Allergy Clin Immunol*. 2012;129(3):860-863. e863.
1227. Anto JM, Sunyer J, Rodriguez-Roisin R, Suarez-Cervera M, Vazquez L. Community outbreaks of asthma associated with inhalation of soybean dust. *N Engl J Med*. 1989;320(17):1097-1102.
1228. Rodrigo MJ, Morell F, Helm RM, et al. Identification and partial characterization of the soybean-dust allergens involved in the Barcelona asthma epidemic. *J Allergy Clin Immunol*. 1990;85(4):778-784.
1229. Codina R, Lockey RF, Fernandez-Caldas E, Rama R. Identification of the soybean hull allergens responsible for the Barcelona asthma outbreaks. *Int Arch Allergy Immunol*. 1999;119(1):69-71.
1230. Thom de Souza CC, Rosario Filho NA, Camargo JF, RHM G. Levels of Airborne Soybean Allergen (Gly m 1) in a Brazilian Soybean Production City: A Pilot Study. *Int J Environ Res Public Health*. 2020;17(15).
1231. Haftenberger M, Laussmann D, Ellert U, et al. Prevalence of sensitization to aeroallergens and food allergens: results of the German Health Interview and Examination Survey for Adults (DEGS1). *Bundesgesundheitsblatt Gesundheitsforschung Gesundheitsschutz*. 2013;56(5-6):687-697.
1232. Ito K, Sjolander S, Sato S, et al. IgE to Gly m 5 and Gly m 6 is associated with severe allergic reactions to soybean in Japanese children. *J Allergy Clin Immunol*. 2011;128(3):673-675.
1233. Matricardi PM, Bockelbrink A, Beyer K, et al. Primary versus secondary immunoglobulin E sensitization to soy and wheat in the Multi-Centre Allergy Study cohort. *Clin Exp Allergy*. 2008;38(3):493-500.
1234. Ebisawa M, Brostedt P, Sjolander S, Sato S, Borres MP, Ito K. Gly m 2S albumin is a major allergen with a high diagnostic value in soybean-allergic children. *J Allergy Clin Immunol*. 2013;132(4):976-978. e971-975.
1235. Ruiz Segura LT, Figueroa Perez E, Nowak-Wegrzyn A, Siepmann T, Larenas-Linnemann D. Food allergen sensitization patterns in a large allergic population in Mexico. *Allergol Immunopathol (Madr)*. 2020;48(6):553-559.
1236. Yamamoto-Hanada K, Borres MP, Aberg MK, et al. IgE responses to multiple allergen components among school-aged children in a general population birth cohort in Tokyo. *World Allergy Organ J*. 2020;13(2):100105.
1237. Klemans RJ, Knol EF, Michelsen-Huisman A, et al. Components in soy allergy diagnostics: Gly m 2S albumin has the best diagnostic value in adults. *Allergy*. 2013;68(11):1396-1402.
1238. Anto JM, Soriano JB, Sunyer J, et al. Long term outcome of soybean epidemic asthma after an allergen reduction intervention. *Thorax*. 1999;54(8):670-674.
1239. Maruyama N, Sato S, Cabanos C, Tanaka A, Ito K, Ebisawa M. Gly m 5/Gly m 8 fusion component as a potential novel candidate molecule for diagnosing soya bean allergy in Japanese children. *Clin Exp Allergy*. 2018;48(12):1726-1734.
1240. Ballmer-Weber BK, Lidholm J, Fernández-Rivas M, et al. IgE recognition patterns in peanut allergy are age dependent: perspectives of the EuroPrevall study. *Allergy*. 2015;70(4):391-407.
1241. Schwager C, Kull S, Behrends J, et al. Peanut oleosins associated with severe peanut allergy-importance of lipophilic allergens for comprehensive allergy diagnostics. *J Allergy Clin Immunol*. 2017;140(5):1331-1338. e1338.
1242. Lauer I, Dueringer N, Pokoj S, et al. The non-specific lipid transfer protein, Ara h 9, is an important allergen in peanut. *Clin Exp Allergy*. 2009;39(9):1427-1437.
1243. Greenhawt M, Shaker M, Wang J, et al. Peanut allergy diagnosis: A 2020 practice parameter update, systematic review, and GRADE analysis. *J Allergy Clin Immunol*. 2020;146(6):1302-1334.

1244. Uotila R, Kukkonen AK, Blom WM, et al. Component-resolved diagnostics demonstrates that most peanut-allergic individuals could potentially introduce tree nuts to their diet. *Clin Exp Allergy*. 2018;48(6):712-721.
1245. Vickery BP, Vereda A, Nilsson C, et al. Continuous and Daily Oral Immunotherapy for Peanut Allergy: Results from a 2-Year Open-Label Follow-On Study. *J Allergy Clin Immunol Pract*. 2021;9(5):1879-1889. e1814.
1246. Chen G, Shrock EL, Li MZ, et al. High-resolution epitope mapping by AllerScan reveals relationships between IgE and IgG repertoires during peanut oral immunotherapy. *Cell Rep Med*. 2021;2(10):100410.
1247. Turner PJ, Jerschow E, Umasunthar T, Lin R, Campbell DE, Boyle RJ. Fatal Anaphylaxis: Mortality Rate and Risk Factors. *J Allergy Clin Immunol Pract*. 2017;5(5):1169-1178.
1248. Umasunthar T, Leonardi-Bee J, Hodes M, et al. Incidence of fatal food anaphylaxis in people with food allergy: a systematic review and meta-analysis. *Clin Exp Allergy*. 2013;43(12):1333-1341.
1249. Bueno-Díaz C, Biserni C, Martín-Pedraza L, et al. Seed storage proteins, 2S albumin and 11S globulin, associated to severe allergic reactions after flaxseed intake. *J Investig Allergol Clin Immunol*. 2022;32:375-382.
1250. García Jiménez S, Pastor Vargas C, de las Heras M, Sanz Maroto A, Vivanco F, Sastre J. Allergen characterization of chia seeds (*Salvia hispanica*), a new allergenic food. *J Investig Allergol Clin Immunol*. 2015;25(1):55-56.
1251. American College of Asthma AI. *Tree nut*. 2021 20-10-2021]. <https://acaai.org/allergies/allergic-conditions/food/tree-nut/>
1252. Blom WM, van Dijk LM, Michelsen-Huisman A, et al. Allergen labelling: Current practice and improvement from a communication perspective. *Clin Exp Allergy*. 2021;51(4):574-584.
1253. Crevel RW, Kerkhoff MA, Koning MM. Allergenicity of refined vegetable oils. *Food Chem Toxicol*. 2000;38(4):385-393.
1254. Caffarelli C, Mastrorilli C, Santoro A, Criscione M, Procaccianti M. Component-Resolved Diagnosis of Hazelnut Allergy in Children. *Nutrients*. 2021;13(2).
1255. Scheurer S, van Ree R, Vieths S. The Role of Lipid Transfer Proteins as Food and Pollen Allergens Outside the Mediterranean Area. *Curr Allergy Asthma Rep*. 2021;21(2):7.
1256. Li J, Ogorodova LM, Mahesh PA, et al. Comparative Study of Food Allergies in Children from China, India, and Russia: The EuroPrevall-INCO Surveys. *J Allergy Clin Immunol Pract*. 2020;8(4):1349-1358. e1316.
1257. Sasaki M, Koplin JJ, Dharmage SC, et al. Prevalence of clinic-defined food allergy in early adolescence: The SchoolNuts study. *J Allergy Clin Immunol*. 2018;141(1):391-398.e394.
1258. McWilliam V, Peters R, Tang MLK, et al. Patterns of tree nut sensitization and allergy in the first 6 years of life in a population-based cohort. *J Allergy Clin Immunol*. 2019;143(2):644-650.e645.
1259. Sirvent S, Akotenou M, Cuesta-Herranz J, et al. The 11S globulin Sin a 2 from yellow mustard seeds shows IgE cross-reactivity with homologous counterparts from tree nuts and peanut. *Clin Transl Allergy*. 2012;2(1):23.
1260. van der Valk JP, Dubois AE, Gerth van Wijk R, Wichers HJ, de Jong NW. Systematic review on cashew nut allergy. *Allergy*. 2014;69(6):692-698.
1261. Vetander M, Helander D, Flodström C, et al. Anaphylaxis and reactions to foods in children—a population-based case study of emergency department visits. *Clin Exp Allergy*. 2012;42(4):568-577.
1262. Andersson K, Ballmer-Weber BK, Cistero-Bahima A, et al. Enhancement of hazelnut extract for IgE testing by recombinant allergen spiking. *Allergy*. 2007;62(8):897-904.
1263. Blankestijn MA, Blom WM, Otten HG, et al. Specific IgE to Jug r 1 has no additional value compared with extract-based testing in diagnosing walnut allergy in adults. *J Allergy Clin Immunol*. 2017;139(2):688-690.e684.
1264. Maruyama N, Nakagawa T, Ito K, et al. Measurement of specific IgE antibodies to Ses i 1 improves the diagnosis of sesame allergy. *Clin Exp Allergy*. 2016;46(1):163-171.
1265. Elizur A, Appel MY, Nachshon L, et al. NUT Co Reactivity - ACquiring Knowledge for Elimination Recommendations (NUT CRACKER) study. *Allergy*. 2018;73(3):593-601.
1266. Brough HA, Caubet JC, Mazon A, et al. Defining challenge-proven coexistent nut and sesame seed allergy: A prospective multicenter European study. *J Allergy Clin Immunol*. 2020;145(4):1231-1239.
1267. Varga EM, Kollmann D, Zach M, Bohle B. Anaphylaxis to buckwheat in an atopic child: a risk factor for severe allergy to nuts and seeds? *Int Arch Allergy Immunol*. 2011;156(1):112-116.
1268. De Maat-Bleeker F, Stapel SO. Cross-reactivity between buckwheat and latex. *Allergy*. 1998;53(5):538-539.
1269. Masthoff L, Pasmans S, van Doorn H, et al. Major hazelnut and peanut allergens are potent in basophil activation and cross-react at T-cell level. *Allergy*. 2018;73(10):2080-2082.
1270. Sampson HA, Gerth van Wijk R, Bindslev-Jensen C, et al. Standardizing double-blind, placebo-controlled oral food challenges: American Academy of Allergy, Asthma & Immunology-European Academy of Allergy and Clinical Immunology PRACTALL consensus report. *J Allergy Clin Immunol*. 2012;130(6):1260-1274.
1271. Muraro A, Worm M, Alviani C, et al. EAACI guidelines: Anaphylaxis (2021 update). *Allergy*. 2022;77(2):357-377.
1272. van Hoffen E, Peeters KA, van Neerven RJ, et al. Effect of birch pollen-specific immunotherapy on birch pollen-related hazelnut allergy. *J Allergy Clin Immunol*. 2011;127:100-101.
1273. Worm M, Moneret-Vautrin A, Scherer K, et al. First European data from the network of severe allergic reactions (NORA). *Allergy*. 2014;69(10):1397-1404.
1274. Bucher C, Korner P, Wüthrich B. Allergy to bumblebee venom. *Curr Opin Allergy Clin Immunol*. 2001;1(4):361-365.
1275. Bilò B, Mosbech H, et al; EAACI Interest Group on Insect Venom Hypersensitivity. Diagnosis of Hymenoptera venom allergy. *Allergy*. 2005;60(11):1339-1349. doi:10.1111/j.1398-9995.2005.00963.x
1276. Arzt L, Bokanovic D, Schrautzer C, et al. Immunological differences between insect venom-allergic patients with and without immunotherapy and asymptotically sensitized subjects. *Allergy*. 2018;73(6):1223-1231.
1277. Golden DB. Insect sting allergy and venom immunotherapy: a model and a mystery. *J Allergy Clin Immunol*. 2005;115(3):439-447. quiz 448.
1278. Antonicelli L, Bilò MB, Bonifazi F. Epidemiology of Hymenoptera allergy. *Curr Opin Allergy Clin Immunol*. 2002;2(4):341-346.
1279. Blank S, Bilò MB, Ollert M. Component-resolved diagnostics to direct in venom immunotherapy: Important steps towards precision medicine. *Clin Exp Allergy*. 2018;48(4):354-364.
1280. Blank SBM, Grosch J, et al. Marker allergens in Hymenoptera venom allergy — Characteristics and potential use in precision medicine. *Allergo J Int*. 2021;30(1):26-38. doi:10.1007/s40629-020-00151-5
1281. Ruiz B, Serrano P, Verdú M, Moreno C. Sensitization to Api m 1, Api m 2, and Api m 4: association with safety of bee venom immunotherapy. *Ann Allergy Asthma Immunol*. 2015;114(4):350-352.
1282. Hamilton RG, Williams PB. Human IgE antibody serology: a primer for the practicing North American allergist/immunologist. *J Allergy Clin Immunol*. 2010;126(1):33-38.
1283. Cifuentes L, Vosseler S, Blank S, et al. Identification of Hymenoptera venom-allergic patients with negative specific IgE to venom extract by using recombinant allergens. *J Allergy Clin Immunol*. 2014;133(3):909-910.
1284. Rafei-Shamsabadi D, Müller S, Pfützner W, Spillner E, Ruëff F, Jakob T. Recombinant allergens rarely allow identification of Hymenoptera venom-allergic patients with negative

- specific IgE to whole venom preparations. *J Allergy Clin Immunol*. 2014;134(2):493-494.
1285. Sturm GJ, Varga EM, Roberts G, et al. EAACI guidelines on allergen immunotherapy: Hymenoptera venom allergy. *Allergy*. 2018;73(4):744-764.
1286. Bilò MB, Pravettoni V, Bignardi D, et al. Hymenoptera Venom Allergy: Management of Children and Adults in Clinical Practice. *J Investig Allergol Clin Immunol*. 2019;29(3):180-205.
1287. Chugo S, Lizaso MT, Alvarez MJ, Arroabaren E, Lizarza S, Tabar AI. *Vespa velutina nigritorax*: A New Causative Agent in Anaphylaxis. *J Investig Allergol Clin Immunol*. 2015;25(3):231-232.
1288. Hoffman DR. Allergens in Hymenoptera venom. XVI: Studies of the structures and cross-reactivities of vespid venom phospholipases. *J Allergy Clin Immunol*. 1986;78(2):337-343.
1289. Monsalve RI, Vega A, Marqués L, et al. Component-resolved diagnosis of vespid venom-allergic individuals: phospholipases and antigen 5s are necessary to identify *Vespula* or *Polistes* sensitization. *Allergy*. 2012;67(4):528-536.
1290. Severino MG, Caruso B, Bonadonna P, et al. Cross reactivity between European hornet and yellow jacket venoms. *Eur Ann Allergy Clin Immunol*. 2010;42(4):141-145.
1291. Kolarich D, Léonard R, Hemmer W, Altmann F. The N-glycans of yellow jacket venom hyaluronidases and the protein sequence of its major isoform in *Vespula vulgaris*. *FEBS J*. 2005;272(20):5182-5190.
1292. Lee VS, Tu WC, Jinn TR, Peng CC, Lin LJ, Tzen JT. Molecular cloning of the precursor polypeptide of mastoparan B and its putative processing enzyme, dipeptidyl peptidase IV, from the black-bellied hornet, *Vespa basalis*. *Insect Mol Biol*. 2007;16(2):231-237.
1293. Blank S, Seismann H, McIntyre M, et al. Vitellogenins are new high molecular weight components and allergens (Api m 12 and Ves v 6) of *Apis mellifera* and *Vespula vulgaris* venom. *PLoS One*. 2013;8(4):e62009.
1294. Winningham KM, Fitch CD, Schmidt M, Hoffman DR. Hymenoptera venom protease allergens. *J Allergy Clin Immunol*. 2004;114(4):928-933.
1295. Grosch J, Hilger C, Bilò MB, et al. Shedding Light on the Venom Proteomes of the Allergy-Relevant Hymenoptera *Polistes dominula* (European Paper Wasp) and *Vespula* spp. (Yellow Jacket). *Toxins (Basel)*. 2020;12(5).
1296. Ebo DG, Faber M, Sabato V, Leysen J, Bridts CH, De Clerck LS. Component-resolved diagnosis of wasp (yellow jacket) venom allergy. *Clin Exp Allergy*. 2013;43(2):255-261.
1297. Michel J, Brockow K, Darsow U, et al. Added sensitivity of component-resolved diagnosis in hymenoptera venom-allergic patients with elevated serum tryptase and/or mastocytosis. *Allergy*. 2016;71(5):651-660.
1298. Vos B, Köhler J, Müller S, Stretz E, Ruëff F, Jakob T. Spiking venom with rVes v 5 improves sensitivity of IgE detection in patients with allergy to *Vespula* venom. *J Allergy Clin Immunol*. 2013;131(4):1225-1227. 1227.e1221.
1299. Sturm GJ, Bilò MB, Bonadonna P, et al. Ves v 5 can establish the diagnosis in patients without detectable specific IgE to wasp venom and a possible north-south difference in Api m 1 sensitization in Europe. *J Allergy Clin Immunol*. 2012;130:817.
1300. Korošec P, Valenta R, Mittermann I, et al. High sensitivity of CAP-FEIA rVes v 5 and rVes v 1 for diagnosis of *Vespula* venom allergy. *J Allergy Clin Immunol*. 2012;129:1406-1408.
1301. Hofmann SC, Pfender N, Weckesser S, Huss-Marp J, Jakob T. Added value of IgE detection to rApi m 1 and rVes v 5 in patients with Hymenoptera venom allergy. *J Allergy Clin Immunol*. 2011;127:265-267.
1302. Šelb J, Kogovšek R, Šilar M, Košnik M, Korošec P. Improved recombinant Api m 1- and Ves v 5-based IgE testing to dissect bee and yellow jacket allergy and their correlation with the severity of the stinging reaction. *Clin Exp Allergy*. 2016;46(4):621-630.
1303. Seismann H, Blank S, Braren I, et al. Dissecting cross-reactivity in hymenoptera venom allergy by circumvention of alpha-1,3-core fucosylation. *Mol Immunol*. 2010;47(4):799-808.
1304. Schrautzer C, Bokanovic D, Hemmer W, et al. Sensitivity and specificity of Hymenoptera allergen components depend on the diagnostic assay employed. *J Allergy Clin Immunol*. 2016;137(5):1603-1605.
1305. Bilò MB, Martini M, Bonadonna P, et al. Prevalence of Pol d 1 Sensitization in *Polistes dominula* Allergy and Its Diagnostic Role in Vespid Double-Positivity. *J Allergy Clin Immunol Pract*. 2021;9(10):3781-3787.
1306. Blank S, Bazon ML, Grosch J, et al. Antigen 5 Allergens of Hymenoptera Venoms and Their Role in Diagnosis and Therapy of Venom Allergy. *Curr Allergy Asthma Rep*. 2020;20(10):58.
1307. Blanca M, Garcia F, Miranda A, et al. Determination of IgE antibodies to *Polistes dominulus*, *Vespula germanica* and *Vespa crabro* in sera of patients allergic to vespids. *Allergy*. 1991;46(2):109-114.
1308. Severino MG, Campi P, Macchia D, et al. European *Polistes* venom allergy. *Allergy*. 2006;61(7):860-863.
1309. Blank S, Neu C, Hasche D, Bantleon FI, Jakob T, Spillner E. *Polistes* species venom is devoid of carbohydrate-based cross-reactivity and allows interference-free diagnostics. *J Allergy Clin Immunol*. 2013;131(4):1239-1242.
1310. Golden DB, Demain J, Freeman T, et al. Stinging insect hypersensitivity: A practice parameter update 2016. *Ann Allergy Asthma Immunol*. 2017;118(1):28-54.
1311. Golden DB, Kelly D, Hamilton RG, Wang NY, Kagey-Sobotka A. Dialyzed venom skin tests for identifying yellow jacket-allergic patients not detected using standard venom. *Ann Allergy Asthma Immunol*. 2009;102(1):47-50.
1312. Pantera B, Hoffman DR, Carresi L, et al. Characterization of the major allergens purified from the venom of the paper wasp *Polistes gallicus*. *Biochim Biophys Acta*. 2003;1623(2-3):72-81.
1313. Macchia D, Cortellini G, Mauro M, et al. *Vespa crabro* immunotherapy versus *Vespula*-venom immunotherapy in *Vespa crabro* allergy: a comparison study in field re-stings. *World Allergy Organ J*. 2018;11(1):3.
1314. Gattinger P, Lupinek C, Kalogiros L, et al. The culprit insect but not severity of allergic reactions to bee and wasp venom can be determined by molecular diagnosis. *PLoS One*. 2018;13(6):e0199250.
1315. Alvarez-Twose I, González de Olano D, Sánchez-Muñoz L, et al. Clinical, biological, and molecular characteristics of clonal mast cell disorders presenting with systemic mast cell activation symptoms. *J Allergy Clin Immunol*. 2010;125(6):1269-1278.e1262.
1316. Vos B, van Anrooij B, van Doormaal JJ, Dubois AEJ, Oude Elberink JNG. Fatal Anaphylaxis to Yellow Jacket Stings in Mastocytosis: Options for Identification and Treatment of At-Risk Patients. *J Allergy Clin Immunol Pract*. 2017;5(5):1264-1271.
1317. Galindo-Bonilla PA, Galán-Nieto A, Alfaya-Arias T, García-Rodríguez C, de la Roca-Pinzón F, Feo-Brito F. Component-resolved diagnosis in vespid venom-allergic individuals. *Allergol Immunopathol (Madr)*. 2015;43(4):398-402.
1318. Jakob T, Müller U, Helbling A, Spillner E. Component resolved diagnostics for hymenoptera venom allergy. *Curr Opin Allergy Clin Immunol*. 2017;17(5):363-372.
1319. Caruso B, Bonadonna P, Severino MG, et al. Evaluation of the IgE cross-reactions among vespid venoms. A possible approach for the choice of immunotherapy. *Allergy*. 2007;62(5):561-564.
1320. Savi E, Peveri S, Makri E, Pravettoni V, Incorvaia C. Comparing the ability of molecular diagnosis and CAP-inhibition in identifying the really causative venom in patients with positive tests to *Vespula* and *Polistes* species. *Clin Mol Allergy*. 2016;14:3.
1321. Quercia O, Cova V, Martini M, et al. CAP-Inhibition, Molecular Diagnostics, and Total IgE in the Evaluation of *Polistes* and

- Vespula Double Sensitization. *Int Arch Allergy Immunol*. 2018;177(4):365-369.
1322. Dalmau Duch G, Gázquez García V, Gaig Jané P, Galán Nieto A, Monsalve Clemente RI. Importance of controlled sting challenge and component-resolved diagnosis in the success of venom immunotherapy. *J Investig Allergol Clin Immunol*. 2012;22(2):135-136.
1323. Korošec P, Šilar M, Erzen R, et al. Clinical routine utility of basophil activation testing for diagnosis of hymenoptera-allergic patients with emphasis on individuals with negative venom-specific IgE antibodies. *Int Arch Allergy Immunol*. 2013;161(4):363-368.
1324. Eberlein B, Krischan L, Darsow U, Ollert M, Ring J. Double positivity to bee and wasp venom: improved diagnostic procedure by recombinant allergen-based IgE testing and basophil activation test including data about cross-reactive carbohydrate determinants. *J Allergy Clin Immunol*. 2012;130(1):155-161.
1325. Peternelj A, Silar M, Erzen R, Kosnik M, Korosec P. Basophil sensitivity in patients not responding to venom immunotherapy. *Int Arch Allergy Immunol*. 2008;146(3):248-254.
1326. Ruëff F, Przybilla B, Müller U, Mosbech H. The sting challenge test in Hymenoptera venom allergy. Position paper of the Subcommittee on Insect Venom Allergy of the European Academy of Allergology and Clinical Immunology. *Allergy*. 1996;51(4):216-225.
1327. Sturm GJ, Herzog SA, Aberer W, et al. β -blockers and ACE inhibitors are not a risk factor for severe systemic sting reactions and adverse events during venom immunotherapy. *Allergy*. 2021;76(7):2166-2176.
1328. Bilò MB, Cichocka-Jarosz E, Pumphrey R, et al. Self-medication of anaphylactic reactions due to Hymenoptera stings—an EAACI Task Force Consensus Statement. *Allergy*. 2016;71(7):931-943.
1329. Kranert P, Forchhammer S, Volc S, Stenger F, Schaller M, Fischer J. Safety and Effectiveness of a 3-Day Rush Insect Venom Immunotherapy Protocol. *Int Arch Allergy Immunol*. 2020;181(2):111-118.
1330. Bonadonna P, Gonzalez-de-Olano D, Zanotti R, et al. Venom immunotherapy in patients with clonal mast cell disorders: efficacy, safety, and practical considerations. *J Allergy Clin Immunol Pract*. 2013;1(5):474-478.
1331. Quirce S, Bernstein JA. Old and new causes of occupational asthma. *Immunol Allergy Clin North Am*. 2011;31(4):677-698. v.
1332. Cartier A. New causes of immunologic occupational asthma, 2012-2014. *Curr Opin Allergy Clin Immunol*. 2015;15(2):117-123.
1333. Tarlo SM, Malo JL, de Blay F, et al. An Official American Thoracic Society Workshop Report: Presentations and Discussion of the Sixth Jack Pepys Workshop on Asthma in the Workplace. *Ann Am Thorac Soc*. 2017;14(9):1361-1372.
1334. Raulf M. Allergen component analysis as a tool in the diagnosis of occupational allergy. *Curr Opin Allergy Clin Immunol*. 2016;16(2):93-100.
1335. Raulf M, Quirce S, Vandenplas O. Addressing Molecular Diagnosis of Occupational Allergies. *Curr Allergy Asthma Rep*. 2018;18(1):6.
1336. Raulf M. Allergen component analysis as a tool in the diagnosis and management of occupational allergy. *Mol Immunol*. 2018;100:21-27.
1337. Raulf M. The latex story. *Chem Immunol Allergy*. 2014;100:248-255.
1338. Vandenplas O, Raulf M. Occupational Latex Allergy: the Current State of Affairs. *Curr Allergy Asthma Rep*. 2017;17(3):14.
1339. Raulf M. Current state of occupational latex allergy. *Curr Opin Allergy Clin Immunol*. 2020;20(2):112-116.
1340. Parisi CAS, Kelly KJ, Ansotegui IJ, et al. Update on latex allergy: New insights into an old problem. *World Allergy Organ J*. 2021;14(8):100569.
1341. Slater JE, Vedvick T, Arthur-Smith A, Trybul DE, Kekwick RG. Identification, cloning, and sequence of a major allergen (Hev b 5) from natural rubber latex (*Hevea brasiliensis*). *J Biol Chem*. 1996;271(41):25394-25399.
1342. Posch A, Chen Z, Raulf-Heimsoth M, Baur X. Latex allergens. *Clin Exp Allergy*. 1998;28(2):134-140.
1343. Raulf-Heimsoth M, Rihs HP, Rozynek P, et al. Quantitative analysis of immunoglobulin E reactivity profiles in patients allergic or sensitized to natural rubber latex (*Hevea brasiliensis*). *Clin Exp Allergy*. 2007;37(11):1657-1667.
1344. Vandenplas O, Froidure A, Meurer U, et al. The role of allergen components for the diagnosis of latex-induced occupational asthma. *Allergy*. 2016;71(6):840-849.
1345. Ebo DG, Hagendorens MM, De Knop KJ, et al. Component-resolved diagnosis from latex allergy by microarray. *Clin Exp Allergy*. 2010;40(2):348-358.
1346. Peixinho C, Tavares-Ratado P, Tomás MR, Taborda-Barata L, Tomaz CT. Latex allergy: new insights to explain different sensitization profiles in different risk groups. *Br J Dermatol*. 2008;159(1):132-136.
1347. Wagner S, Breiteneder H. The latex-fruit syndrome. *Biochem Soc Trans*. 2002;30(Pt 6):935-940.
1348. Barre A, Culerrier R, Granier C, et al. Mapping of IgE-binding epitopes on the major latex allergen Hev b 2 and the cross-reacting 1,3beta-glucanase fruit allergens as a molecular basis for the latex-fruit syndrome. *Mol Immunol*. 2009;46(8-9):1595-1604.
1349. Chen Z, Posch A, Cremer R, Raulf-Heimsoth M, Baur X. Identification of hevein (Hev b 6.02) in *Hevea* latex as a major cross-reacting allergen with avocado fruit in patients with latex allergy. *J Allergy Clin Immunol*. 1998;102(3):476-481.
1350. Posch A, Wheeler CH, Chen Z, et al. Class I endochitinase containing a hevein domain is the causative allergen in latex-associated avocado allergy. *Clin Exp Allergy*. 1999;29(5):667-672.
1351. Raulf-Heimsoth M, Stark R, Sander I, et al. Anaphylactic reaction to apple juice containing acerola: cross-reactivity to latex due to prohevein. *J Allergy Clin Immunol*. 2002;109:715-716.
1352. Schmidt MHH, Raulf-Heimsoth M, Posch A. Evaluation of patatin as a major cross-reactive allergen in latex-induced potato allergy. *Ann Allergy Asthma Immunol*. 2002;89(6):613-618.
1353. Brandi SL, Poulsen LK, Garvey LH. The Clinical Relevance of Natural Rubber Latex-Specific IgE in Patients Sensitized to Timothy Grass Pollen. *Int Arch Allergy Immunol*. 2019;178(4):345-354.
1354. Raulf-Heimsoth M, Kespohl S, Crespo JF, et al. Natural rubber latex and chestnut allergy: cross-reactivity or co-sensitization? *Allergy*. 2007;62(11):1277-1281.
1355. Rihs HP, Ruëff F, Lundberg M, et al. Relevance of the recombinant lipid transfer protein of *Hevea brasiliensis*: IgE-binding reactivity in fruit-allergic adults. *Ann Allergy Asthma Immunol*. 2006;97(5):643-649.
1356. Kespohl S, Schlünssen V, Jacobsen G, et al. Impact of cross-reactive carbohydrate determinants on wood dust sensitization. *Clin Exp Allergy*. 2010;40(7):1099-1106.
1357. Hemmer W, Altmann F, Holzweber F, Gruber C, Wantke F, Wöhrl S. ImmunoCAP cellulose displays cross-reactive carbohydrate determinant (CCD) epitopes and can cause false-positive test results in patients with high anti-CCD IgE antibody levels. *J Allergy Clin Immunol*. 2018;141(1):372-381.e373.
1358. Huss-Marp J, Raulf M, Jakob T. Spiking with recombinant allergens to improve allergen extracts: benefits and limitations for the use in routine diagnostics: Part 19 of the Series Molecular Allergology. *Allergo J Int*. 2015;24:236-243.
1359. Quirce S, Diaz-Perales A. Diagnosis and management of grain-induced asthma. *Allergy Asthma Immunol Res*. 2013;5(6):348-356.
1360. Brisman J. Baker's asthma. *Occup Environ Med*. 2002;59(7):498-502. quiz 502, 426.
1361. Sander I, Flagge A, Merget R, Halder TM, Meyer HE, Baur X. Identification of wheat flour allergens by means of 2-dimensional immunoblotting. *J Allergy Clin Immunol*. 2001;107(5):907-913.

1362. van Kampen V, de Blay F, Folletti I, et al. Evaluation of commercial skin prick test solutions for selected occupational allergens. *Allergy*. 2013;68(5):651-658.
1363. van Kampen V, de Blay F, Folletti I, et al. EAACI position paper: skin prick testing in the diagnosis of occupational type I allergies. *Allergy*. 2013;68(5):580-584.
1364. Olivieri M, Biscardo CA, Palazzo P, et al. Wheat IgE profiling and wheat IgE levels in bakers with allergic occupational phenotypes. *Occup Environ Med*. 2013;70(9):617-622.
1365. Gómez-Casado C, Garrido-Arandia M, Pereira C, et al. Component-resolved diagnosis of wheat flour allergy in baker's asthma. *J Allergy Clin Immunol*. 2014;134(2):480-483.
1366. Sander I, Rihs HP, Brüning T, Raulf M. A further wheat allergen for baker's asthma: Tri a 40. *J Allergy Clin Immunol*. 2016;137(4):1286.
1367. Sussman GL, Beezhold DH, Cohn JR, Silvers WS, Zeiger JS, Nayak AP. Cannabis: An Emerging Occupational Allergen? *Ann Work Expo Health*. 2020;64(7):679-682.
1368. Decuyper II, Van Gasse A, Faber MA, et al. Occupational cannabis exposure and allergy risks. *Occup Environ Med*. 2019;76(2):78-82.
1369. Decuyper II, Faber MA, Lapeere H, et al. Cannabis allergy: A diagnostic challenge. *Allergy*. 2018;73(9):1911-1914.
1370. Quirce S, Polo F, Figueredo E, González R, Sastre J. Occupational asthma caused by soybean flour in bakers—differences with soybean-induced epidemic asthma. *Clin Exp Allergy*. 2000;30(6):839-846.
1371. Peters U, Frenzel K, Brettschneider R, Oldenburg M, Bittner C. Identification of two metallothioneins as novel inhalative coffee allergens cof a 2 and cof a 3. *PLoS One*. 2015;10(5):e0126455.
1372. Kespohl S, Kotschy-Lang N, Tomm JM, et al. Occupational IgE-mediated softwood allergy: characterization of the causative allergen. *Int Arch Allergy Immunol*. 2012;157(2):202-208.
1373. Kespohl S, Sander I, Merget R, et al. Identification of an obeche (*Triplochiton scleroxylon*) wood allergen as a class I chitinase. *Allergy*. 2005;60(6):808-814.
1374. Hannu T, Lindström I, Palmroos P, Kuuliala O, Sauni R. Prediction of obeche wood-induced asthma by specific skin prick testing. *Occup Med (Lond)*. 2013;63(6):429-431.
1375. Aranda A, Campo P, Palacin A, et al. Antigenic proteins involved in occupational rhinitis and asthma caused by obeche wood (*Triplochiton scleroxylon*). *PLoS One*. 2013;8(1):e53926.
1376. Zahradnik E, Raulf M. Animal allergens and their presence in the environment. *Front Immunol*. 2014;5:76.
1377. Caballero ML, Ordaz E, Bermejo M, et al. Characterization of occupational sensitization by multiallergen immunoblotting in workers exposed to laboratory animals. *Ann Allergy Asthma Immunol*. 2012;108(3):178-181.
1378. Choi GS, Kim JH, Lee HN, Sung JM, Lee JW, Park HS. Occupational asthma caused by inhalation of bovine serum albumin powder. *Allergy Asthma Immunol Res*. 2009;1(1):45-47.
1379. Toskala E, Piipari R, Aalto-Korte K, Tuppurainen M, Kuuliala O, Keskinen H. Occupational asthma and rhinitis caused by milk proteins. *J Occup Environ Med*. 2004;46:1100-1101.
1380. Bernaola G, Echechipia S, Urrutia I, Fernández E, Audicana M, Fernández de Corres L. Occupational asthma and rhinoconjunctivitis from inhalation of dried cow's milk caused by sensitization to alpha-lactalbumin. *Allergy*. 1994;49(3):189-191.
1381. Olaguibel JM, Hernandez D, Morales P, Peris A, Basomba A. Occupational asthma caused by inhalation of casein. *Allergy*. 1990;45(4):306-308.
1382. Lopata AL, Kleine-Tebbe J, Kamath SD. Allergens and molecular diagnostics of shellfish allergy: Part 22 of the Series Molecular Allergology. *Allergo J Int*. 2016;25(7):210-218.
1383. Wilfinger D, Kuehn A, Takacs S, Galli-Novak E, Machan B, Aberer W. Occupational allergic contact urticaria to tropomyosin from squid. *Allergol Select*. 2020;4:129-134.
1384. Siracusa A, Folletti I, Gerth van Wijk R, et al. Occupational anaphylaxis—an EAACI task force consensus statement. *Allergy*. 2015;70(2):141-152.
1385. Larsen AI, Cederkvist L, Lykke AM, Wagner P, Johnsen CR, Poulsen LK. Allergy Development in Adulthood: An Occupational Cohort Study of the Manufacturing of Industrial Enzymes. *J Allergy Clin Immunol Pract*. 2020;8(1):210-218.e215.
1386. Kespohl S, Raulf M. Mould allergens: Where do we stand with molecular allergy diagnostics?: Part 13 of the series Molecular Allergology. *Allergo J Int*. 2014;23(4):120-125.
1387. Kespohl S, Maryska S, Bünger J, et al. How to diagnose mould allergy? Comparison of skin prick tests with specific IgE results. *Clin Exp Allergy*. 2016;46(7):981-991.
1388. Allmers H, Huber H, Baur X. Two year follow-up of a garbage collector with allergic bronchopulmonary aspergillosis (ABPA). *Am J Ind Med*. 2000;37(4):438-442.
1389. Poole CJ, Wong M. Allergic bronchopulmonary aspergillosis in garden waste (compost) collectors—occupational implications. *Occup Med (Lond)*. 2013;63(7):517-519.
1390. Preisser AM, Koschel D, Merget R, Nowak D, Raulf M, Heidrich J. Workplace-related inhalation test - Specific inhalation challenge: S2k Guideline of the German Society for Occupational and Environmental Medicine e.V. (DGAUM), the German Society for Pneumology and Respiratory Medicine e.V. (DGP) and the German Society for Allergology and Clinical Immunology e.V. (DGAKI). *Allergol Select*. 2021;5:315-334.
1391. Raulf M. Occupational Respiratory Allergy: Risk Factors, Diagnosis, and Management. *Handb Exp Pharmacol*. 2022;268:213-225.
1392. van Kampen V, Rabstein S, Sander I, et al. Prediction of challenge test results by flour-specific IgE and skin prick test in symptomatic bakers. *Allergy*. 2008;63(7):897-902.
1393. Witke W. The role of profilin complexes in cell motility and other cellular processes. *Trends Cell Biol*. 2004;14(8):461-469.
1394. Valenta R, Duchene M, Ebner C, et al. Profilins constitute a novel family of functional plant pan-allergens. *J Exp Med*. 1992;175(2):377-385.
1395. Mari A. Multiple pollen sensitization: a molecular approach to the diagnosis. *Int Arch Allergy Immunol*. 2001;125(1):57-65.
1396. Núñez R, Carballeda F, Lombardero M, Jimeno L, Boquete M. Profilin as an aeroallergen by means of conjunctival allergen challenge with purified date palm profilin. *Int Arch Allergy Immunol*. 2012;158(2):115-119.
1397. Ruiz-García M, García Del Potro M, Fernández-Nieto M, Barber D, Jimeno-Nogales L, Sastre J. Profilin: a relevant aeroallergen? *J Allergy Clin Immunol*. 2011;128:416-418.
1398. Asero R, Villalta D. Profilin may be a primary airborne sensitizer: a case report. *J Investig Allergol Clin Immunol*. 2013;23(2):134-135.
1399. Ruiz-Hornillos J, López-Matas MA, Berges Jimeno P, et al. Profilin is a marker of severity in allergic respiratory diseases. *Allergy*. 2020;75(4):853-861.
1400. Wensing M, Akkerdaas JH, van Leeuwen WA, et al. IgE to Bet v 1 and profilin: cross-reactivity patterns and clinical relevance. *J Allergy Clin Immunol*. 2002;110(3):435-442.
1401. Reindl J, Rihs HP, Scheurer S, Wangorsch A, Hausteiner D, Vieths S. IgE reactivity to profilin in pollen-sensitized subjects with adverse reactions to banana and pineapple. *Int Arch Allergy Immunol*. 2002;128(2):105-114.
1402. Rodríguez-Perez R, Crespo JF, Rodríguez J, Salcedo G. Profilin is a relevant melon allergen susceptible to pepsin digestion in patients with oral allergy syndrome. *J Allergy Clin Immunol*. 2003;111(3):634-639.
1403. Westphal S, Kempf W, Foetisch K, Retzek M, Vieths S, Scheurer S. Tomato profilin Lyc e 1: IgE cross-reactivity and allergenic potency. *Allergy*. 2004;59(5):526-532.
1404. Anliker MD, Reindl J, Vieths S, Wüthrich B. Allergy caused by ingestion of persimmon (*Diospyros kaki*): detection of specific IgE

- and cross-reactivity to profilin and carbohydrate determinants. *J Allergy Clin Immunol*. 2001;107(4):718-723.
1405. Reindl J, Anliker MD, Karamloo F, Vieths S, Wüthrich B. Allergy caused by ingestion of zucchini (Cucurbita pepo): characterization of allergens and cross-reactivity to pollen and other foods. *J Allergy Clin Immunol*. 2000;106(2):379-385.
1406. Asero R, Mistrello G, Amato S. The nature of melon allergy in ragweed-allergic subjects: A study of 1000 patients. *Allergy Asthma Proc*. 2011;32(1):64-67.
1407. Palacin A, Quirce S, Sanchez-Monge R, et al. Sensitization profiles to purified plant food allergens among pediatric patients with allergy to banana. *Pediatr Allergy Immunol*. 2011;22(2):186-195.
1408. Alvarado MI, Jimeno L, De La Torre F, et al. Profilin as a severe food allergen in allergic patients overexposed to grass pollen. *Allergy*. 2014;69(12):1610-1616.
1409. Kapingidza AB, Pye SE, Hyduke N, et al. Comparative structural and thermal stability studies of Cuc m 2.0101, Art v 4.0101 and other allergenic profilins. *Mol Immunol*. 2019;114:19-29.
1410. Quercia O, Stefanini GF, Scardovi A, Asero R. Patients monosensitized to Hev b 8 (Hevea brasiliensis latex profilin) may safely undergo major surgery in a normal (non-latex safe) environment. *Eur Ann Allergy Clin Immunol*. 2009;41(4):112-116.
1411. Schuler S, Ferrari G, Schmid-Grendelmeier P, Harr T. Microarray-based component-resolved diagnosis of latex allergy: isolated IgE-mediated sensitization to latexprofilin Hev b8 may act as confounder. *Clin Transl Allergy*. 2013;3(1):11.
1412. Asero R. Hypersensitivity to pollen panallergens (profilin and polcalcin) detected *in vitro* and *in vivo*: a comparative analysis. *J Investig Allergol Clin Immunol*. 2011;21(4):323-324.
1413. Villalta D, Asero R. Sensitization to the pollen pan-allergen profilin. Is the detection of immunoglobulin E to multiple homologous proteins from different sources clinically useful? *J Investig Allergol Clin Immunol*. 2010;20(7):591-595.
1414. Asero R, Villalta D. Are anti-Phl p 12 IgE levels predictive of oral allergy syndrome in profilin hypersensitive patients? *Eur Ann Allergy Clin Immunol*. 2011;43(6):184-187.
1415. Ganglberger E, Radauer C, Wagner S, et al. Hev b 8, the Hevea brasiliensis latex profilin, is a cross-reactive allergen of latex, plant foods and pollen. *Int Arch Allergy Immunol*. 2001;125(3):216-227.
1416. Sirvent S, Tordesillas L, Villalba M, et al. Pollen and plant food profilin allergens show equivalent IgE reactivity. *Ann Allergy Asthma Immunol*. 2011;106(5):429-435.
1417. Asero R, Mistrello G, Roncarolo D, Amato S. Parietaria profilin shows only limited cross-reactivity with birch and grass profilins. *Int Arch Allergy Immunol*. 2004;133(2):121-124.
1418. Bonura A, Trapani A, Gulino L, et al. Cloning, expression in *E. coli* and immunological characterization of Par j 3.0201, a Parietaria pollen profilin variant. *Mol Immunol*. 2014;57(2):220-225.
1419. Scala E, Abeni D, Guerra EC, et al. Cosensitization to profilin is associated with less severe reactions to foods in nsLTPs and storage proteins reactors and with less severe respiratory allergy. *Allergy*. 2018;73(9):1921-1923.
1420. Kelso JM, Jones RT, Tellez R, Yunginger JW. Oral allergy syndrome successfully treated with pollen immunotherapy. *Ann Allergy Asthma Immunol*. 1995;74(5):391-396.
1421. Asero R, Mistrello G, Amato S. Detection of pan-allergens in commercial pollen extracts for allergen immunotherapy. *Ann Allergy Asthma Immunol*. 2016;117(2):180-185.
1422. Obeso D, Mera-Berriatua L, Rodríguez-Coira J, et al. Multi-omics analysis points to altered platelet functions in severe food-associated respiratory allergy. *Allergy*. 2018;73(11):2137-2149.
1423. Lund G, Brand S, Ramos T, et al. Strong and frequent T-cell responses to the minor allergen Phl p 12 in Spanish patients IgE-sensitized to Profilins. *Allergy*. 2018;73(5):1013-1021.
1424. Barber D, Villaseñor A, Escobese MM. Metabolomics strategies to discover new biomarkers associated to severe allergic phenotypes. *Asia Pac Allergy*. 2019;9(4):e37.
1425. Breiteneder H, Pettenburger K, Bito A, et al. The gene coding for the major birch pollen allergen Betv1, is highly homologous to a pea disease resistance response gene. *EMBO J*. 1989;8(7):1935-1938.
1426. Gajhede M, Osmark P, Poulsen FM, et al. X-ray and NMR structure of Bet v 1, the origin of birch pollen allergy. *Nat Struct Biol*. 1996;3(12):1040-1045.
1427. Jahn-Schmid B, Radakovics A, Lüttkopf D, et al. Bet v 1142-156 is the dominant T-cell epitope of the major birch pollen allergen and important for cross-reactivity with Bet v 1-related food allergens. *J Allergy Clin Immunol*. 2005;116(1):213-219.
1428. Kitzmüller C, Zulehner N, Roulias A, et al. Correlation of sensitizing capacity and T-cell recognition within the Bet v 1 family. *J Allergy Clin Immunol*. 2015;136(1):151-158.
1429. Gepp B, Lengger N, Bublin M, Hemmer W, Breiteneder H, Radauer C. Chimeras of Bet v 1 and Api g 1 reveal heterogeneous IgE responses in patients with birch pollen allergy. *J Allergy Clin Immunol*. 2014;134(1):188-194.
1430. Antoniw JFRC, Pierpoints WS, et al. Comparison of three pathogenesis-related proteins from plants of two cultivars of tobacco infected with TMV. *J Gen Virol*. 1980;47:79-87. doi:10.1099/0022-1317-47-1-79
1431. Ali S, Ganai BA, Kamili AN, et al. Pathogenesis-related proteins and peptides as promising tools for engineering plants with multiple stress tolerance. *Microbiol Res*. 2018;212-213:29-37.
1432. Geroldinger-Simic M, Zelniker T, Aberer W, et al. Birch pollen-related food allergy: clinical aspects and the role of allergen-specific IgE and IgG4 antibodies. *J Allergy Clin Immunol*. 2011;127(3):616-622.
1433. Hauser M, Asam C, Himly M, et al. Bet v 1-like pollen allergens of multiple Fagales species can sensitize atopic individuals. *Clin Exp Allergy*. 2011;41(12):1804-1814.
1434. Breiteneder H, Ebner C. Molecular and biochemical classification of plant-derived food allergens. *J Allergy Clin Immunol*. 2000;106(1 Pt 1):27-36.
1435. Moneo I, Gómez M, Sánchez-Monge R, et al. Lack of crossreaction with Bet v 1 in patients sensitized to Dau c 1, a carrot allergen. *Ann Allergy Asthma Immunol*. 1999;83(1):71-75.
1436. Ballmer-Weber BK, Wüthrich B, Wangorsch A, Fötisch K, Altmann F, Vieths S. Carrot allergy: double-blinded, placebo-controlled food challenge and identification of allergens. *J Allergy Clin Immunol*. 2001;108(2):301-307.
1437. Moreno-Ancillo A, Gil-Adrados AC, Domínguez-Noche C, Cosmes PM, Pineda F. Occupational asthma due to carrot in a cook. *Allergol Immunopathol (Madr)*. 2005;33(5):288-290.
1438. Flinterman AE, Akkerdaas JH, den Hartog Jager CF, et al. Lipid transfer protein-linked hazelnut allergy in children from a non-Mediterranean birch-endemic area. *J Allergy Clin Immunol*. 2008;121(2):423-428.
1439. Aglas L, Soh WT, Kraiem A, Wenger M, Brandstetter H, Ferreira F. Ligand binding of PR-10 proteins with a particular focus on the Bet v 1 allergen family. *Curr Allergy Asthma Rep*. 2020;20(7):25.
1440. Jacob T, von Loetzen CS, Reuter A, et al. Identification of a natural ligand of the hazel allergen Cor a 1. *Sci Rep*. 2019;9(1):8714.
1441. Seutter von Loetzen C, Jacob T, Hartl-Spiegelhauer O, et al. Ligand recognition of the major birch pollen allergen bet v 1 is isoform dependent. *PLoS One*. 2015;10(6):e0128677.
1442. Casañal A, Zander U, Muñoz C, et al. The strawberry pathogenesis-related 10 (PR-10) Fra proteins control flavonoid biosynthesis by binding to metabolic intermediates. *J Biol Chem*. 2013;288(49):35322-35332.
1443. Mogensen JE, Wimmer R, Larsen JN, Spangfort MD, Otzen DE. The major birch allergen, Bet v 1, shows

- affinity for a broad spectrum of physiological ligands. *J Biol Chem.* 2002;277(26):23684-23692.
1444. Muñoz C, Hoffmann T, Escobar NM, et al. The strawberry fruit Fra a allergen functions in flavonoid biosynthesis. *Mol Plant.* 2010;3(1):113-124.
1445. Seutter von Loetzen C, Hoffmann T, Hartl MJ, et al. Secret of the major birch pollen allergen Bet v 1: identification of the physiological ligand. *Biochem J.* 2014;457(3):379-390.
1446. Lee KS, Kim K, Choi YJ, et al. Increased sensitization rates to tree pollens in allergic children and adolescents and a change in the pollen season in the metropolitan area of Seoul, Korea. *Pediatr Allergy Immunol.* 2021;32(5):872-879.
1447. Villalta D, Asero R. Is the detection of IgE to multiple Bet v 1-homologous food allergens by means of allergen microarray clinically useful? *J Allergy Clin Immunol.* 2010;125:1158-1161.
1448. Cochrane SA, Salt LJ, Wantling E, et al. Development of a standardized low-dose double-blind placebo-controlled challenge vehicle for the EuroPrevall project. *Allergy.* 2012;67(1):107-113.
1449. Nothegger B, Reider N, Covaciu CE, et al. Oral birch pollen immunotherapy with apples: Results of a phase II clinical pilot study. *Immun Inflamm Dis.* 2021;9(2):503-511.
1450. Salcedo G, Sánchez-Monge R, Barber D, Díaz-Perales A. Plant non-specific lipid transfer proteins: an interface between plant defence and human allergy. *Biochim Biophys Acta.* 2007;1771(6):781-791.
1451. Pastorello EA, Monza M, Pravettoni V, et al. Characterization of the T-cell epitopes of the major peach allergen Pru p 3. *Int Arch Allergy Immunol.* 2010;153(1):1-12.
1452. Cavatorta V, Sforza S, Aquino G, et al. *In vitro* gastrointestinal digestion of the major peach allergen Pru p 3, a lipid transfer protein: molecular characterization of the products and assessment of their IgE binding abilities. *Mol Nutr Food Res.* 2010;54(10):1452-1457.
1453. Barber D, Díaz-Perales A, Escribese MM, et al. Molecular allergology and its impact in specific allergy diagnosis and therapy. *Allergy.* 2021;76(12):3642-3658.
1454. Skypala IJ, Bartra J, Ebo DG, et al. The diagnosis and management of allergic reactions in patients sensitized to non-specific lipid transfer proteins. *Allergy.* 2021;76(8):2433-2446.
1455. Dubiela P, Dölle-Bierke S, Aurich S, Worm M, Hoffmann-Sommergruber K. Component-resolved diagnosis in adult patients with food-dependent anaphylaxis. *World Allergy Organ J.* 2021;14(3):100530.
1456. Oeo-Santos C, Navas A, Benedé S, et al. New insights into the sensitization to nonspecific lipid transfer proteins from pollen and food: New role of allergen Ole e 7. *Allergy.* 2020;75(4):798-807.
1457. Palacín A, Gómez-Casado C, Rivas LA, et al. Graph based study of allergen cross-reactivity of plant lipid transfer proteins (LTPs) using microarray in a multicenter study. *PLoS One.* 2012;7(12):e50799.
1458. Díaz-Perales A, Tabar AI, Sánchez-Monge R, et al. Characterization of asparagus allergens: a relevant role of lipid transfer proteins. *J Allergy Clin Immunol.* 2002;110(5):790-796.
1459. Tordesillas L, Pacios LF, Palacín A, et al. Molecular basis of allergen cross-reactivity: non-specific lipid transfer proteins from wheat flour and peach fruit as models. *Mol Immunol.* 2009;47(2-3):534-540.
1460. Pastorello EA, Farioli L, Pravettoni V, et al. Pru p 3-sensitized Italian peach-allergic patients are less likely to develop severe symptoms when also presenting IgE antibodies to Pru p 1 and Pru p 4. *Int Arch Allergy Immunol.* 2011;156(4):362-372.
1461. Ruano-Zaragoza M, Somoza ML, Jiménez-Rodríguez TW, et al. Lipid transfer protein sensitization: risk of anaphylaxis and molecular sensitization profile in Pru p 3-sensitized patients. *Int Arch Allergy Immunol.* 2021;182(5):425-432.
1462. Mota I, Gaspar Â, Benito-García F, et al. Anaphylaxis caused by lipid transfer proteins: an unpredictable clinical syndrome. *Allergol Immunopathol (Madr).* 2018;46(6):565-570.
1463. Pastorello EA, Farioli L, Stafylaraki C, et al. Wheat-dependent exercise-induced anaphylaxis caused by a lipid transfer protein and not by ω -5 gliadin. *Ann Allergy Asthma Immunol.* 2014;112(4):386-387.e381.
1464. Palomares F, Gomez F, Bogas G, et al. Immunological changes induced in peach allergy patients with systemic reactions by Pru p 3 sublingual immunotherapy. *Mol Nutr Food Res.* 2018;62(3).
1465. Majorek KA, Porebski PJ, Dayal A, et al. Structural and immunologic characterization of bovine, horse, and rabbit serum albumins. *Mol Immunol.* 2012;52(3-4):174-182.
1466. Fiocchi A, Restani P, Riva E, et al. Heat treatment modifies the allergenicity of beef and bovine serum albumin. *Allergy.* 1998;53(8):798-802.
1467. Chruszcz M, Mikolajczak K, Mank N, Majorek KA, Porebski PJ, Minor W. Serum albumins-unusual allergens. *Biochim Biophys Acta.* 2013;1830(12):5375-5381.
1468. Jenkins JA, Breiteneder H, Mills EN. Evolutionary distance from human homologs reflects allergenicity of animal food proteins. *J Allergy Clin Immunol.* 2007;120(6):1399-1405.
1469. Fanta C, Ebner C. Allergy to mare's milk. *Allergy.* 1998;53(5):539-540.
1470. Drouet M, Sabbah A, Le Sellin J, Bonneau JC, Gay G, Dubois-Gosnet C. Fatal anaphylaxis after eating wild boar meat in a patient with pork-cat syndrome. *Allerg Immunol (Paris).* 2001;33(4):163-165.
1471. Morisset M, Arumugam K, Ollert M, Hilger C. Horse-meat allergy mediated by dog-allergy: a case report and review of the literature. *Allergo J.* 2016;25(3):30-35.
1472. Alvarez-Perea A, Caralli ME, Zubeldia JM, Baeza ML. Pork-cat syndrome as a cause of occupational asthma. *J Investig Allergol Clin Immunol.* 2014;24(3):209-211.
1473. Quirce S, Maranon F, Umpierrez A. de las Heras M, Fernandez-Caldas E, Sastre J. Chicken serum albumin (Gal d 5*) is a partially heat-labile inhalant and food allergen implicated in the bird-egg syndrome. *Allergy.* 2001;56(8):754-762.
1474. WHO. WHO expert committee on biological standardization. World Health Organ Tech Rep Ser; 2007;(941):1-340
1475. de Silva R, Dasanayake W, Wickramasinha GD, et al. Sensitization to bovine serum albumin as a possible cause of allergic reactions to vaccines. *Vaccine.* 2017;35(11):1494-1500.
1476. Dewachter P, Jacquenet S, Beloucif S, Goarin JP, Koskas F, Mouton-Faivre C. Pork-cat syndrome revealed after surgery: Anaphylaxis to bovine serum albumin tissue adhesive. *J Allergy Clin Immunol Pract.* 2019;7(7):2450-2452.
1477. Hilger C, Clark E, Swiontek K, et al. Anaphylaxis to bovine serum albumin tissue adhesive in a non-meat-allergic patient. *J Investig Allergol Clin Immunol.* 2020;30(5):369-371.
1478. Kasahara A, Kita K, Tomita E, Toyota J, Imai Y, Kumada H. Repeated administration of recombinant human serum albumin caused no serious allergic reactions in patients with liver cirrhosis: a multicenter clinical study. *J Gastroenterol.* 2008;43(6):464-472.
1479. Moreno Lozano L, Galindo Bonilla P, Borja Segade J, Extremera Ortega A, Gomez Torrijos E, Garcia Rodriguez R. Human serum albumin induced anaphylaxis in a patient with good tolerance to human plasma. *J Investig Allergol Clin Immunol.* 2019;29(1):51-53.
1480. Wang M, Zhu D, Zhu J, Nussinov R, Ma B. Local and global anatomy of antibody-protein antigen recognition. *J Mol Recognit.* 2018;31(5):e2693.
1481. Wisnewski AV, Liu J, Redlich CA. Antigenic changes in human albumin caused by reactivity with the occupational allergen diphenylmethane diisocyanate. *Anal Biochem.* 2010;400(2):251-258.
1482. Wisnewski AV, Stowe MH, Cartier A, et al. Isocyanate vapor-induced antigenicity of human albumin. *J Allergy Clin Immunol.* 2004;113(6):1178-1184.
1483. Reese G, Schickantz S, Lauer I, et al. Structural, immunological and functional properties of natural recombinant Pen a 1, the major allergen of Brown Shrimp, *Penaeus aztecus*. *Clin Exp Allergy.* 2006;36(4):517-524.

1484. Daul CB, Slattery M, Reese G, Lehrer SB. Identification of the major brown shrimp (*Penaeus aztecus*) allergen as the muscle protein tropomyosin. *Int Arch Allergy Immunol*. 1994;105(1):49-55.
1485. Reese G, Jeoung BJ, Daul CB, Lehrer SB. Characterization of recombinant shrimp allergen Pen a 1 (tropomyosin). *Int Arch Allergy Immunol*. 1997;113(1-3):240-242.
1486. James JK, Pike DH, Khan IJ, Nanda V. Structural and dynamic properties of allergen and non-allergen forms of tropomyosin. *Structure*. 2018;26(7):997-1006.
1487. Hoffman DR, Day ED Jr, Miller JS. The major heat stable allergen of shrimp. *Ann Allergy*. 1981;47(1):17-22.
1488. Naqqal S, Rajappa L, Metcalfe DD, Rao PV. Isolation and characterization of heat-stable allergens from shrimp (*Penaeus indicus*). *J Allergy Clin Immunol*. 1989;83(1):26-36.
1489. Leung PS, Chu KH, Chow WK, et al. Cloning, expression, and primary structure of *Metapenaeus ensis* tropomyosin, the major heat-stable shrimp allergen. *J Allergy Clin Immunol*. 1994;94(5):882-890.
1490. Ayuso R, Reese G, Leong-Kee S, Plante M, Lehrer SB. Molecular basis of arthropod cross-reactivity: IgE-binding cross-reactive epitopes of shrimp, house dust mite and cockroach tropomyosins. *Int Arch Allergy Immunol*. 2002;129(1):38-48.
1491. Leung NY, Wai CY, Shu S, et al. Current immunological and molecular biological perspectives on seafood allergy: a comprehensive review. *Clin Rev Allergy Immunol*. 2014;46(3):180-197.
1492. Yi FC, Cheong N, Shek LP, Wang DY, Chua KY, Lee BW. Identification of shared and unique immunoglobulin E epitopes of the highly conserved tropomyosins in *Blomia tropicalis* and *Dermatophagoides pteronyssinus*. *Clin Exp Allergy*. 2002;32(8):1203-1210.
1493. Leung PS, Chow WK, Duffey S, Kwan HS, Gershwin ME, Chu KH. IgE reactivity against a cross-reactive allergen in crustacea and mollusca: evidence for tropomyosin as the common allergen. *J Allergy Clin Immunol*. 1996;98(5 Pt 1):954-961.
1494. Cantillo JF, Puerta L, Fernandez-Caldas E, et al. Tropomyosins in mosquito and house dust mite cross-react at the humoral and cellular level. *Clin Exp Allergy*. 2018;48(10):1354-1363.
1495. Sokol WN. Grasshopper sensitization in patients allergic to crustaceans, mites, and cockroaches: should grasshopper-containing products carry a warning? *Ann Allergy Asthma Immunol*. 2020;124(5):518-520.
1496. Palmer LK, Marsh JT, Lu M, Goodman RE, Zeece MG, Johnson PE. Shellfish tropomyosin IgE cross-reactivity differs among edible insect species. *Mol Nutr Food Res*. 2020;64(8):e1900923.
1497. Santos AB, Rocha GM, Oliver C, et al. Cross-reactive IgE antibody responses to tropomyosins from *Ascaris lumbricoides* and cockroach. *J Allergy Clin Immunol*. 2008;121(4):1040-1046.
1498. Acevedo N, Sánchez J, Erler A, et al. IgE cross-reactivity between *Ascaris* and domestic mite allergens: the role of tropomyosin and the nematode polyprotein ABA-1. *Allergy*. 2009;64(11):1635-1643.
1499. Kamath SD, Johnston EB, Iyer S, et al. IgE reactivity to shrimp allergens in infants and their cross-reactivity to house dust mite. *Pediatr Allergy Immunol*. 2017;28(7):703-707.
1500. Zakzuk J, Mercado D, Bornacelly A, et al. Hygienic conditions influence sensitization to *Blomia tropicalis* allergenic components: Results from the FRAAT birth cohort. *Pediatr Allergy Immunol*. 2019;30(2):172-178.
1501. Buendía E, Zakzuk J, Mercado D, Alvarez A, Caraballo L. The IgE response to *Ascaris* molecular components is associated with clinical indicators of asthma severity. *World Allergy Organ J*. 2015;8(1):8.
1502. Sousa-Santos A, Moreno AS, Santos ABR, et al. Parasite infections, allergy and asthma: a role for tropomyosin in promoting type 2 immune responses. *Int Arch Allergy Immunol*. 2020;181(3):221-227.
1503. Asero R, Pravettoni V, Scala E, Villalta D. House dust mite-shrimp allergen interrelationships. *Curr Allergy Asthma Rep*. 2020;20(4):9.
1504. Fernandes J, Reshef A, Patton L, Ayuso R, Reese G, Lehrer SB. Immunoglobulin E antibody reactivity to the major shrimp allergen, tropomyosin, in unexposed Orthodox Jews. *Clin Exp Allergy*. 2003;33(7):956-961.
1505. Liu R, Holck AL, Yang E, Liu C, Xue W. Tropomyosin from tilapia (*Oreochromis mossambicus*) as an allergen. *Clin Exp Allergy*. 2013;43(3):365-377.
1506. Weghofer M, Thomas WR, Kronqvist M, et al. Variability of IgE reactivity profiles among European mite allergic patients. *Eur J Clin Invest*. 2008;38(12):959-965.
1507. Cantillo JF, Fernández-Caldas E, Puerta L. Immunological aspects of the immune response induced by mosquito allergens. *Int Arch Allergy Immunol*. 2014;165(4):271-282.
1508. Celi G, Brusca I, Scala E, et al. House dust mite allergy and shrimp allergy: a complex interaction. *Eur Ann Allergy Clin Immunol*. 2020;52(5):205-209.
1509. Iparraguirre A, Rodríguez-Pérez R, Juste S, Ledesma A, Moneo I, Caballero ML. Selective allergy to lobster in a case of primary sensitization to house dust mites. *J Investig Allergol Clin Immunol*. 2009;19(5):409-413.
1510. Niederberger V, Hayek B, Vrtala S, et al. Calcium-dependent immunoglobulin E recognition of the apo- and calcium-bound form of a cross-reactive two EF-hand timothy grass pollen allergen, Phl p 7. *FASEB J*. 1999;13(8):843-856.
1511. Henzl MT, Davis ME, Tan A. Polcalcin divalent ion-binding behavior and thermal stability: comparison of Bet v 4, Bra n 1, and Bra n 2 to Phl p 7. *Biochemistry*. 2010;49(10):2256-2268.
1512. Barderas R, Villalba M, Pascual CY, Batanero E, Rodríguez R. Profilin (Che a 2) and polcalcin (Che a 3) are relevant allergens of *Chenopodium album* pollen: isolation, amino acid sequences, and immunologic properties. *J Allergy Clin Immunol*. 2004;113(6):1192-1198.
1513. Movérare R, Larsson H, Carlsson R, Holmquist I. Mugwort-sensitized individuals from North Europe, South Europe and North America show different IgE reactivity patterns. *Int Arch Allergy Immunol*. 2011;154(2):164-172.
1514. Orovitg A, Guardia P, Barber D, et al. Enhanced diagnosis of pollen allergy using specific immunoglobulin E determination to detect major allergens and panallergens. *J Investig Allergol Clin Immunol*. 2011;21(4):253-259.
1515. San Nicolás M, Braun T, Eder K, Berghaus A, Gröger M. Clinical relevance of IgE to profilin and/or polcalcin in pollen-sensitized patients. *Int Arch Allergy Immunol*. 2016;169(2):101-107.
1516. Compés E, Hernández E, Quirce S, et al. Hypersensitivity to black locust (*Robinia pseudoacacia*) pollen: "allergy mirages". *Ann Allergy Asthma Immunol*. 2006;96(4):586-592.
1517. Moya R, González-Ruiz A, Beitia JM, Carnés J, López-Matas M. Ole e 3, a candidate for *in vivo* diagnosis of polcalcin sensitization. *Int Arch Allergy Immunol*. 2021;182(6):465-473.
1518. Engel E, Richter K, Obermeyer G, et al. Immunological and biological properties of Bet v 4, a novel birch pollen allergen with two EF-hand calcium-binding domains. *J Biol Chem*. 1997;272(45):28630-28637.
1519. Gregoire C, Rosinski-Chupin I, Rabillon J, Alzari PM, David B, Dandeu JP. cDNA cloning and sequencing reveal the major horse allergen Equ c1 to be a glycoprotein member of the lipocalin superfamily. *J Biol Chem*. 1996;271(51):32951-32959.
1520. Lascombe MB, Grégoire C, Poncet P, et al. Crystal structure of the allergen Equ c 1. A dimeric lipocalin with restricted IgE-reactive epitopes. *J Biol Chem*. 2000;275(28):21572-21577.
1521. Goubran Botros H, Poncet P, Rabillon J, Fontaine T, Laval JM, David B. Biochemical characterization and surfactant properties of horse allergens. *Eur J Biochem*. 2001;268(10):3126-3136.
1522. Llicardi G, Emenius G, Merritt AS, Salzillo A, D'Amato M, D'Amato G. Direct and indirect exposure to horse: risk for sensitization and asthma. *Curr Allergy Asthma Rep*. 2012;12(5):429-437.
1523. Merritt AS, Emenius G, Elfman L, Smedje G. Measurement of horse allergen (Equ cx) in schools. *ISRN Allergy*. 2011;2011:574258.

1524. Immonen A, Kinnunen T, Sirven P, et al. The major horse allergen Equ c 1 contains one immunodominant region of T cell epitopes. *Clin Exp Allergy*. 2007;37(6):939-947.
1525. Haka J, Niemi MH, Mattila P, Jänis J, Takkinen K, Rouvinen J. Development of hypoallergenic variants of the major horse allergen Equ c 1 for immunotherapy by rational structure based engineering. *Sci Rep*. 2019;9(1):20148.
1526. Wintersand A, Alsveld M, Jakobsson J, et al. Individual airborne characteristics of dog allergens. *Clin Exp Allergy*. 2021.
1527. Custovic A, Green R, Fletcher A, et al. Aerodynamic properties of the major dog allergen Can f 1: distribution in homes, concentration, and particle size of allergen in the air. *Am J Respir Crit Care Med*. 1997;155(1):94-98.
1528. Chruszcz M, Kapingidza AB, Dolamore C, Kowal K. A robust method for the estimation and visualization of IgE cross-reactivity likelihood between allergens belonging to the same protein family. *PLoS One*. 2018;13(11):e0208276.
1529. Hilger C, Swiontek K, Arumugam K, Lehnert C, Hentges F. Identification of a new major dog allergen highly cross-reactive with Fel d 4 in a population of cat- and dog-sensitized patients. *J Allergy Clin Immunol*. 2012;129(4):1149-1151.
1530. Apostolovic D, Sánchez-Vidaurre S, Waden K, et al. The cat lipocalin Fel d 7 and its cross-reactivity with the dog lipocalin Can f 1. *Allergy*. 2016;71(10):1490-1495.
1531. Hemmer W, Sestak-Greinecker G, Braunsteiner T, Wantke F, Wöhrl S. Molecular sensitization patterns in animal allergy: Relationship with clinical relevance and pet ownership. *Allergy*. 2021;76:3687-3696.
1532. Madhurantakam C, Nilsson OB, Uchtenhagen H, et al. Crystal structure of the dog lipocalin allergen Can f 2: implications for cross-reactivity to the cat allergen Fel d 4. *J Mol Biol*. 2010;401(1):68-83.
1533. Mattsson L, Lundgren T, Olsson P, Sundberg M, Lidholm J. Molecular and immunological characterization of Can f 4: a dog dander allergen cross-reactive with a 23 kDa odorant-binding protein in cow dander. *Clin Exp Allergy*. 2010;40(8):1276-1287.
1534. Jakob T, Hilger C, Hentges F. Clinical relevance of sensitization to cross-reactive lipocalin Can f 6. *Allergy*. 2013;68(5):690-691.
1535. Shewry PR, Napier JA, Tatham AS. Seed storage proteins: structures and biosynthesis. *Plant Cell*. 1995;7(7):945-956.
1536. Slavokhotova AA, Rogozhin EA. Defense peptides from the α -hairpinin family are components of plant innate immunity. *Front Plant Sci*. 2020;11:465.
1537. Aalberse RC, Mueller GA, Derksen NIL, et al. Identification of the amino-terminal fragment of Ara h 1 as a major target of the IgE-binding activity in the basic peanut protein fraction. *Clin Exp Allergy*. 2020;50(3):401-405.
1538. Peeters KA, Koppelman SJ, Penninks AH, et al. Clinical relevance of sensitization to lupine in peanut-sensitized adults. *Allergy*. 2009;64(4):549-555.
1539. Verhoeckx KCM, Vissers YM, Baumert JL, et al. Food processing and allergenicity. *Food Chem Toxicol*. 2015;80:223-240.
1540. Klemans RJ, van Os-Medendorp H, Blankestijn M, Bruijnzeel-Koomen CA, Knol EF, Knulst AC. Diagnostic accuracy of specific IgE to components in diagnosing peanut allergy: a systematic review. *Clin Exp Allergy*. 2015;45(4):720-730.
1541. Lange L, Lasota L, Finger A, et al. Ana o 3-specific IgE is a good predictor for clinically relevant cashew allergy in children. *Allergy*. 2017;72(4):598-603.
1542. Sato S, Yamamoto M, Yanagida N, et al. Jug r 1 sensitization is important in walnut-allergic children and youth. *J Allergy Clin Immunol Pract*. 2017;5(6):1784-1786.
1543. Cabanillas B, Jappe U, Novak N. Allergy to peanut, soybean, and other legumes: recent advances in allergen characterization, stability to processing and IgE cross-reactivity. *Mol Nutr Food Res*. 2018;62(1).
1544. Geiselhart S, Hoffmann-Sommergruber K, Bublin M. Tree nut allergens. *Mol Immunol*. 2018;100:71-81.
1545. López-Torrejón G, Salcedo G, Martín-Esteban M, Díaz-Perales A, Pascual CY, Sánchez-Monge R. Len c 1, a major allergen and vicilin from lentil seeds: protein isolation and cDNA cloning. *J Allergy Clin Immunol*. 2003;112(6):1208-1215.
1546. Blankestijn MA, den Hartog Jager CF, Blom WM, et al. A subset of walnut allergic adults is sensitized to walnut 11S globulin Jug r 4. *Clin Exp Allergy*. 2018;48(9):1206-1213.
1547. Kabasser S, Hafner C, Chinthrajah S, et al. Identification of Pru du 6 as a potential marker allergen for almond allergy. *Allergy*. 2021;76(5):1463-1472.
1548. Magni C, Ballabio C, Restani P, et al. Molecular insight into IgE-mediated reactions to sesame (*Sesamum indicum* L.) seed proteins. *Ann Allergy Asthma Immunol*. 2010;105(6):458-464.
1549. Klemans RJ, Otte D, Knol M, et al. The diagnostic value of specific IgE to Ara h 2 to predict peanut allergy in children is comparable to a validated and updated diagnostic prediction model. *J Allergy Clin Immunol*. 2013;131(1):157-163.
1550. Ballmer-Weber BK, Lidholm J, Lange L, et al. Allergen recognition patterns in walnut allergy are age dependent and correlate with the severity of allergic reactions. *J Allergy Clin Immunol Pract*. 2019;7(5):1560-1567.
1551. Garcia-Blanca A, Aranda A, Blanca-Lopez N, et al. Influence of age on IgE response in peanut-allergic children and adolescents from the Mediterranean area. *Pediatr Allergy Immunol*. 2015;26(6):497-502.
1552. Villalta D, Scala E, Mistrello G, Amato S, Asero R. Evidence of cross-reactivity between different seed storage proteins from hazelnut (*Corylus avellana*) and Walnut (*Juglans regia*) using recombinant allergen proteins. *Int Arch Allergy Immunol*. 2019;178(1):89-92.
1553. Bublin M, Breiteneder H. Cross-reactivities of non-homologous allergens. *Allergy*. 2020;75(5):1019-1022.
1554. Bublin M, Kostadinova M, Radauer C, et al. IgE cross-reactivity between the major peanut allergen Ara h 2 and the nonhomologous allergens Ara h 1 and Ara h 3. *J Allergy Clin Immunol*. 2013;132(1):118-124.
1555. Croote D, Darmanis S, Nadeau KC, Quake SR. High-affinity allergen-specific human antibodies cloned from single IgE B cell transcriptomes. *Science*. 2018;362(6420):1306-1309.
1556. Stiefel G, Anagnostou K, Boyle RJ, et al. BSACI guideline for the diagnosis and management of peanut and tree nut allergy. *Clin Exp Allergy*. 2017;47(6):719-739.
1557. Chan ES, Greenhawt MJ, Fleischer DM, Caubet JC. Managing cross-reactivity in those with peanut allergy. *J Allergy Clin Immunol Pract*. 2019;7(2):381-386.
1558. Martínez San Ireneo M, Ibáñez MD, Fernández-Caldas E, Carnés J. *In vitro* and *in vivo* cross-reactivity studies of legume allergy in a Mediterranean population. *Int Arch Allergy Immunol*. 2008;147(3):222-230.
1559. Masthoff LJ, van Hoffen E, Mattsson L, et al. Peanut allergy is common among hazelnut-sensitized subjects but is not primarily the result of IgE cross-reactivity. *Allergy*. 2015;70(3):265-274.
1560. Valcour A, Lidholm J, Borres MP, Hamilton RG. Sensitization profiles to hazelnut allergens across the United States. *Ann Allergy Asthma Immunol*. 2019;122(1):111-116.e111.
1561. Inomata N, Okazaki F, Moriyama T, et al. Identification of peamaclein as a marker allergen related to systemic reactions in peach allergy. *Ann Allergy Asthma Immunol*. 2014;112(2):175-177.
1562. Su T, Han M, Cao D, Xu M. Molecular and biological properties of snakins: the foremost cysteine-rich plant host defense peptides. *J Fungi (Basel)*. 2020;6(4).
1563. Tanaka N, Konishi H, Khan MM, Komatsu S. Proteome analysis of rice tissues by two-dimensional electrophoresis: an approach to the investigation of gibberellin regulated proteins. *Mol Genet Genomics*. 2004;270(6):485-496.

1564. Hedden P, Sponsel V. A century of gibberellin research. *J Plant Growth Regul.* 2015;34(4):740-760.
1565. Almasia NI, Nahirnak V, Hopp HE, Vazquez-Rovere C. Potato Snakin-1: an antimicrobial player of the trade-off between host defense and development. *Plant Cell Rep.* 2020;39(7):839-849.
1566. Gao S, Chu C. Gibberellin metabolism and signaling: targets for improving agronomic performance of crops. *Plant Cell Physiol.* 2020;61(11):1902-1911.
1567. Yeung H, Squire CJ, Yosaatmadja Y, et al. Radiation damage and racemic protein crystallography reveal the unique structure of the GASA/snakin protein superfamily. *Angew Chem Int Ed Engl.* 2016;55(28):7930-7933.
1568. Tuppo L, Alessandri C, Pasquariello MS, et al. Pomegranate cultivars: identification of the new IgE-binding protein pommaclein and analysis of anti-oxidant variability. *J Agric Food Chem.* 2017;65(13):2702-2710.
1569. Inomata N, Miyagawa M, Aihara M. Gibberellin-regulated protein in Japanese apricot is an allergen cross-reactive to Pru p 7. *Immun Inflamm Dis.* 2017;5:469-479.
1570. Inomata N, Miyakawa M, Ikeda N, Oda K, Aihara M. Identification of gibberellin-regulated protein as a new allergen in orange allergy. *Clin Exp Allergy.* 2018;48(11):1509-1520.
1571. Shahali Y, Nicaise P, Brazdova A, et al. Complementarity between microarray and immunoblot for the comparative evaluation of IgE repertoire of french and italian cypress pollen allergic patients. *Folia Biol (Praha).* 2014;60(4):192-201.
1572. Sénéchal H, Santrucek J, Melcova M, et al. A new allergen family involved in pollen food associated syndrome: snakin/gibberellin regulated proteins. *J Allergy Clin Immunol.* 2018;141(1):411-414.
1573. Hugues B, Didierlaurent A, Charpin D. Cross-reactivity between cypress pollen and peach: a report of seven cases. *Allergy.* 2006;61(10):1241-1243.
1574. Martinez S, Gouitaa M, Tummino C, Chanez P, Charpin D. The cypress/citrus syndrome. *Rev Fr Allergol.* 2015;55(4):305-307.
1575. Sénéchal H, Charpin D, Couderc R, Poncet P. Gibberellin-regulated proteins and the enigma of the « missing link ». *Rev Fr Allergol.* 2018;58:63-67.
1576. Poncet P, Aizawa T, Senechal H. The subtype of Cupressaceae pollinosis associated with Pru p 7 sensitization is characterized by a sensitization to a cross-reactive gibberellin-regulated protein in cypress pollen: BP14. *Clin Exp Allergy.* 2019;49(8):1163-1166.
1577. Iizuka T, Takei M, Saito Y, et al. Gibberellin-regulated protein sensitization in Japanese cedar (*Cryptomeria japonica*) pollen allergic Japanese cohorts. *Allergy.* 2021;76:2297-2302.
1578. Poncet P, Senechal H, Charpin D. Update on pollen-food allergy syndrome. *Expert Rev Clin Immunol.* 2020;16(6):561-578.
1579. Saitou N, Nei M. The neighbor-joining method: a new method for reconstructing phylogenetic trees. *Mol Biol Evol.* 1987;4:406-425.
1580. Kumar S, Stecher G, Li M, et al. MEGA X: molecular evolutionary genetics analysis across computing platforms. *Mol Biol Evol.* 2018;35:1547-1549.
1581. Hotta A, Inomata N, Tanegasima T, Oda K, Inoue Y, Aihara M. Case of food-dependent exercise-induced anaphylaxis due to peach with Pru p 7 sensitization. *J Dermatol.* 2016;43(2):222-223.
1582. Asero R, Celi G, Scala E. Labile plant food allergens: really so harmless? Case series and literature review. *Allergy.* 2020;75:1517-1518.
1583. Asero R, Aruanno A, Bresciani M, et al. Evaluation of two commercial peach extracts for skin prick testing in the diagnosis of hypersensitivity to lipid transfer protein. A multicenter study. *Eur Ann Allergy Clin Immunol.* 2020.
1584. Olszewski A, Pons L, Moutété F, et al. Isolation and characterization of proteic allergens in refined peanut oil. *Clin Exp Allergy.* 1998;28(7):850-859.
1585. Pons L, Olszewski A, Guéant JL. Characterization of the oligomeric behavior of a 16.5 kDa peanut oleosin by chromatography and electrophoresis of the iodinated form. *J Chromatogr B Biomed Sci Appl.* 1998;706(1):131-140.
1586. Pons L, Chery C, Romano A, Namour F, Artesani MC, Guéant JL. The 18 kDa peanut oleosin is a candidate allergen for IgE-mediated reactions to peanuts. *Allergy.* 2002;57(Suppl 72):88-93.
1587. Li M, Smith LJ, Clark DC, Wilson R, Murphy DJ. Secondary structures of a new class of lipid body proteins from oilseeds. *J Biol Chem.* 1992;267(12):8245-8253.
1588. Jappe U, Schwager C. Relevance of lipophilic allergens in food allergy diagnosis. *Curr Allergy Asthma Rep.* 2017;17(9):61.
1589. Lin LJ, Tzen JT. Two distinct steroleosins are present in seed oil bodies. *Plant Physiol Biochem.* 2004;42(7-8):601-608.
1590. Tzen J, Wang M, Chen J, Lin L, Chen M. Seed oil body proteins: oleosin, caleosin, and steroleosin. *Curr Topics Biochem Res.* 2003;5:133-139.
1591. Frandsen GI, Mundy J, Tzen JT. Oil bodies and their associated proteins, oleosin and caleosin. *Physiologia Plantarum.* 2001;112(3):301-307.
1592. Murphy DJ, Keen JN, Osullivan JN, et al. A class of amphipathic proteins associated with lipid storage bodies in plants. Possible similarities with animal serum apolipoproteins. *Biochim Biophys Acta.* 1991;1088(1):86-94.
1593. Leprince OVAA, Pritchard H, et al. Oleosins prevent oil-body coalescence during seed imbibition as suggested by a low-temperature scanning electron microscope study of desiccation-tolerant and-sensitive oilseeds. *Planta.* 1997;204(1):109-119. doi:10.1007/s004250050236
1594. Tzen JT, Lai YK, Chan KL, Huang AH. Oleosin isoforms of high and low molecular weights are present in the oil bodies of diverse seed species. *Plant Physiol.* 1990;94(3):1282-1289.
1595. www.allergen.org.
1596. Akkerdaas JH, Schocker F, Vieths S, et al. Cloning of oleosin, a putative new hazelnut allergen, using a hazelnut cDNA library. *Mol Nutr Food Res.* 2006;50(1):18-23.
1597. Nebbia S, Lamberti C, Cirrincione S, et al. Oleosin Cor a 15 is a novel allergen for Italian hazelnut allergic children. *Pediatr Allergy Immunol.* 2021;32(8):1743-1755.
1598. Schwager C, Kull S, Krause S, et al. Development of a novel strategy to isolate lipophilic allergens (oleosins) from peanuts. *PLoS One.* 2015;10(4):e0123419.
1599. Kobayashi S, Katsuyama S, Wagatsuma T, Okada S, Tanabe S. Identification of a new IgE-binding epitope of peanut oleosin that cross-reacts with buckwheat. *Biosci Biotechnol Biochem.* 2012;76(6):1182-1188.
1600. Chen F, Li H, Fan X, et al. Identification of a Novel Major Allergen in Buckwheat Seeds: Fag t 6. *J Agric Food Chem.* 2021;69(45):13315-13322.
1601. Leduc V, Moneret-Vautrin DA, Tzen JT, Morisset M, Guerin L, Kanny G. Identification of oleosins as major allergens in sesame seed allergic patients. *Allergy.* 2006;61(3):349-356.
1602. Commission Directive 2006/142/EC of 22 December 2006 amending Annex IIIa of Directive 2000/13/EC of the European Parliament and of the Council listing the ingredients which must under all circumstances appear on the labelling of foodstuffs. *Off J Eur Union.* 2006;368(110):110-111.
1603. Ehlers AM, Rossnagel M, Brix B, et al. Sesame oleosins are minor allergens. *Clin Transl Allergy.* 2019;9:32.
1604. Behrends J, Schwager C, Hein M, Scholzen T, Kull S, Jappe U. Innovative robust basophil activation test using a novel gating strategy reliably diagnosing allergy with full automation. *Allergy.* 2021;76(12):3776-3788.
1605. Della-Torre E, Pignatti P, Yacoub MR, Sabbadini MG, Colombo G. In vivo tests with "Tahini" sauce: new allergenic source to evaluate IgE-mediated hypersensitivity to sesame. *Ann Allergy Asthma Immunol.* 2013;110(3):209-210.

1606. Majsiak E, Choina M, Miśkiewicz K, Doniec Z, Kurzawa R. Oleosins: a short allergy review. *Adv Exp Med Biol*. 2021;1324:51-55.
1607. Anemüller WFY, Angün O, et al. Relevante sensibilisierung gegen risikoallergene der erndnung bei einem säugling mit atopischen. *Ekzem Allergologie*. 2013;36:397-403.
1608. Teodorowicz M, Terlouw RJ, Jansen A, Savelkoul HF, Ruinemans-Koerts J. Immunological characterization of Dutch sesame seed-allergic patients. *Int Arch Allergy Immunol*. 2016;169(1):13-22.
1609. Das Dores S, Chopin C, Villaume C, Fleurence J, Guéant JL. A new oligomeric parvalbumin allergen of Atlantic cod (Gad ml) encoded by a gene distinct from that of Gad cl. *Allergy*. 2002;57:79-83.
1610. Moraes AH, Ackerbauer D, Kostadinova M, et al. Solution and high-pressure NMR studies of the structure, dynamics, and stability of the cross-reactive allergenic cod parvalbumin Gad m 1. *Proteins*. 2014;82:3032-3042.
1611. Schwaller B. The continuing disappearance of "pure" Ca²⁺ buffers. *Cell Mol Life Sci*. 2009;66:275-300.
1612. Kobayashi A, Tanaka H, Hamada Y, Ishizaki S, Nagashima Y, Shiomi K. Comparison of allergenicity and allergens between fish white and dark muscles. *Allergy*. 2006;61:357-363.
1613. Perez-Gordo M, Lin J, Bardina L, et al. Epitope mapping of Atlantic salmon major allergen by peptide microarray immunoassay. *Int Arch Allergy Immunol*. 2011;157:31-40.
1614. Freidl R, Gstoettner A, Baranyi U, et al. Blocking antibodies induced by immunization with a hypoallergenic parvalbumin mutant reduce allergic symptoms in a mouse model of fish allergy. *J Allergy Clin Immunol*. 2017;139:1897-1905.
1615. Patriarca G, Nucera E, Pollastrini E, et al. Oral specific desensitization in food-allergic children. *Dig Dis Sci*. 2007;52:1662-1672.
1616. Hilger C, Thill L, Grigioni F, et al. IgE-antibodies of fish allergic patients cross-react with frog parvalbumin. *Allergy*. 2004;59:653-660.
1617. Imakiire R, Fujisawa T, Nagao M, et al. Basophil activation test based on CD203C expression in the diagnosis of fish allergy. *Allergy Asthma Immunol Res*. 2020;12:641-652.
1618. Kalic T, Ellinger I, Kamath SD, et al. Fish-derived low molecular weight components modify bronchial epithelial barrier properties and release of pro-inflammatory cytokines. *Mol Immunol*. 2019;112:140-150.
1619. Untersmayr E, Poulsen LK, Platzer MH, et al. The effects of gastric digestion on codfish allergenicity. *J Allergy Clin Immunol*. 2005;115:377-382.
1620. Raposo De Magalhães C, Schrama D, Fonseca F, et al. Effect of EDTA enriched diets on farmed fish allergenicity and muscle quality; a proteomics approach. *Food Chem*. 2020;305:125508.
1621. Kuehn A, Hutt-Kempf E, Hilger C, Hentges F. Clinical monosensitivity to salmonid fish linked to specific IgE-epitopes on salmon and trout beta-parvalbumins. *Allergy*. 2011;66:298-299.
1622. Haroun-Díaz E, Blanca-López N, Vázquez de la Torre M, et al. Severe anaphylaxis due to crocodile-meat allergy exhibiting wide cross-reactivity with fish allergens. *J Allergy Clin Immunol Pract*. 2018;6:669-670.
1623. Asturias JA, Ibarrola I, Eserverri JL, et al. PCR-based cloning and immunological characterization of *Parietaria judaica* pollen profilin. *J Investig Allergol Clin Immunol*. 2004;14:43-48.
1624. Szewzyk R, Becker K, Hünken A, et al. *Kinder-Umwelt-Survey (KUS) 2003/06 Sensibilisierung gegenüber Innenraum Schimmelpilzen*. Schriftreihe Umwelt & Gesundheit im Auftrag des Umweltbundesamt; 2011.
1625. Gent JF, Kezik JM, Hill ME, et al. Household mold and dust allergens: exposure, sensitisation and childhood asthma morbidity. *Environ Res*. 2012;118:86-93. doi:10.1016/j.envres.2012.07.005
1626. Forkel S, Beutner C, Schröder SS, et al. Sensitisation against fungi in patients with airway allergies over 20 years in Germany. *Int Arch Allergy Immunol*. 2021;182:515-523. doi:10.1159/000512230
1627. Toppila-Salmi S, Huhtala H, Karjalainen J, et al. Sensitisation pattern affects the asthma risk in Finnish adult population. *Allergy*. 2015;70:1112-1120. doi:10.1111/all.12670
1628. Cramer R, Zeller S, Glaser AG, et al. Cross-reactivity among fungal allergens: a clinically relevant phenomenon? *Mycoses*. 2009;52:99-106. doi:10.1111/j.1439-0507.2008.01644.x
1629. Michalska K, Fernandes H, Sikorski M, Jaskolski M. Crystal structure of Hyp-1, a St. John's wort protein implicated in the biosynthesis of hypericin. *J Struct Biol*. 2010;169(2):161-171. doi:10.1016/j.jsb.2009.10.008
1630. Sliwiak J, Dauter Z, Jaskolski M. Crystal structure of Hyp-1, a *Hypericum perforatum* PR-10 protein, in complex with melatonin. *Front Plant Sci*. 2016;7:668. doi:10.3389/fpls.2016.00668
1631. Araujo RN, Franco PF, Rodrigues H, et al. Amblyomma sculptum tick saliva: α -Gal identification, antibody response and possible association with red meat allergy in Brazil. *Int J Parasitol*. 2016;46(3):213-220. doi:10.1016/j.ijpara.2015.12.005
1632. Chinuki Y, Ishiwata K, Yamaji K, et al. Haemaphysalis longicornis tick bites are a possible cause of red meat allergy in Japan. *Allergy*. 2016;71(3):421-425.
1633. Hilger C, Fischer J, Swiontek K, et al. Two galactose- α -1,3-galactose carrying peptidases from pork kidney mediate anaphylactogenic responses in delayed meat allergy. *Allergy*. 2016;71(5):711-719. doi:10.1111/all.12835
1634. Apostolovic D, Tran TA, Hamsten C, et al. Immunoproteomics of processed beef proteins reveal novel galactose- α -1,3-galactose-containing allergens. *Allergy*. 2014;69(10):1308-1315. doi:10.1111/all.12462
1635. Schwager C, Kull S, Krause S, et al. Development of a novel strategy to isolate lipophilic allergens from peanuts. *Plos One*. 2015;10(4):e0123419. doi:10.1371/journal.pone.0123419
1636. Incorvaia C, Ridolo E, Mauro M, et al. Allergen immunotherapy for birch-apple syndrome: what do we know? *Immunotherapy*. 2017;9(15):1271-1278.
1637. Arero R. Is there a role for birch pollen immunotherapy on concomitant food allergy? *Curr Treat Options Allergy*. 2015;2(2):83-89.
1638. Vidal C, Armisen M, Monsalve R, et al. Anaphylaxis to *Vespa velutina* nigrithorax: pattern of sensitization for an emerging problem in Western Countries. *J Investig Allergol Clin Immunol*. 2021;31:228-235.
1639. Fauquet J, Rondon C, Calder V, Silva D, Kvenshagen BK. Conjunctival allergen provocation test: guidelines for daily practice. *Allergy*. 2017;72:43-54.
1640. Jiang C, Fan X, Li M, et al. Characterization of Der f 29, a new allergen from dermatophagoides farinae. *Am J Transl Res*. 2015;7:1303-1313.
1641. Gracia IE, Testera A, Rondon C. Medical algorithm: diagnosis and treatment of local allergic rhinitis. *Allergy*. 2021;2927-2930.
1642. Nouri HR, Varasteh A, Vahedi F, Chamani J, Afsharzadeh D, Sankian M. Constructing a hybrid molecule with low capacity of IgE binding from *Chenopodium album* pollen allergens. *Immunol Lett*. 2012;144:67-77.
1643. Tort MJ, Ornberg R, Lay B, Soong F, Salapatek AM. 55 Ocular signs and symptoms elicited by a naturalistic allergen challenge in an environmental exposure chamber model versus a direct allergen instillation model. *World Allergy Organ J*. 2012;5:S35.
1644. Godnic-Cvar J, Susani M, Breiteneder H, et al. Recombinant Bet v 1, the major birch pollen allergen, induces hypersensitivity reactions equal to those induced by natural Bet v 1 in the airways of patients allergic to tree pollen. *J Allergy Clin Immunol*. 1997;99:354-359.
1645. Fischl A, Eckrich J, Passlack V, et al. Comparison of bronchial and nasal allergen provocation in children and adolescents with bronchial asthma and house dust mite sensitization. *Pediatr Allergy Immunol*. 2020;31:143-149.
1646. Käck U, van Hage M, Grönlund H, Lilja G, Asarnej A, Konradsen JR. Allergic sensitization to lipocalins reflects asthma morbidity in dog

- dander sensitized children. *Clin Transl Allergy*. 2022;12(5):e12149. doi:10.1002/clt2.12149
1647. Royer PJ, Emará M, Yang C, et al. The mannose receptor mediates the uptake of diverse native allergens by dendritic cells and determines allergen-induced T cell polarization through modulation of IDO activity. *J Immunol*. 2010;185(3):1522-1531. doi:10.4049/jimmunol.10007745
1648. Hsu SC, Chen CH, Tsai SH, et al. Functional interaction of common allergens and a C-type lectin receptor, dendritic cell-specific ICAM3-grabbing non-integrin (DC-SIGN), on human dendritic cells. *J Biol Chem*. 2010;285(11):7903-7910. doi:10.1074/jbc.M109.058370
1649. Radauer C, Breiteneder H. Evolutionary biology of plant food allergens. *J Allergy Clin Immunol*. 2007;120(3):518-525. doi:10.1016/j.jaci.2007.07.024
1650. Nguyen-Kim H, San Clemente H, Laimer J, et al. The cell wall PAC (proline-rich, arabinogalactan proteins, conserved cysteines) domain-proteins are conserved in the green lineage. *Int J Mol Sci*. 2020;21(7):2488. doi:10.3390/ijms21072488
1651. Kim EH, Andrew Bird J, Kulis M, et al. Sublingual immunotherapy for peanut allergy: clinical and immunologic evidence of desensitization. *J Allergy Clin Immunol*. 2011;127(3):640-646.e1.
1652. Nelson HS, Lahr J, Rule R, Bock A, Leung D. Treatment of anaphylactic sensitivity to peanuts by immunotherapy with injections of aqueous peanut extract. *J Allergy Clin Immunol*. 1997;99(6 Pt 1):744-751.
1653. Vickery BP, Scurlock AM, Kulis M, et al. Sustained unresponsiveness to peanut in subjects who have completed peanut oral immunotherapy. *J Allergy Clin Immunol*. 2014;133(2):468-475.
1654. Foo ACY, Thompson PM, Mueller GA. Removal and replacement of endogenous ligands from lipid-bound proteins and allergens. *J Vis Exp*. 2021;168. doi:10.37971/61780
1655. Borges JP, Barre A, Culerrier R, Archimbaud N, Didier A, Rouge P. How reliable is the structural prediction of IgE-binding epitopes of allergens? The case study of plant lipid transfer proteins. *Biochimie*. 2007;89(1):83-91. doi:10.1016/j.biochi.2006.09.012
1656. Dubiela P, Del Conte R, Cantini F, et al. Impact of lipid binding on the tertiary structure and allergenic potential of Jug r 3, the non-specific lipid transfer protein from walnut. *Sci Rep*. 2019;9(1):2007. doi:10.1038/s41598-019-38563-1
1657. Ziska L, Knowlton K, Rogers C, et al. Recent warming by latitude associated with increased length of ragweed pollen season in central North America. *Proc Natl Acad Sci USA*. 2011;108(10):4248-4251. doi:10.1073/pnas.1014107108
1658. Westman M, Lupinek C, Bousquet J, et al. Early childhood IgE reactivity to pathogenesis-related class 10 proteins predicts allergic rhinitis in adolescence. *J Allergy Clin Immunol*. 2015;135:1199-1206. e1191-1111.
1659. Berneder M, Bublin M, Hoffmann-Sommergruber K, Hawranek T, Lang R. Allergen chip diagnosis for soy-allergic patients: Gly m 4 as a marker for severe food-allergic reactions to soy. *Int Arch Allergy Immunol*. 2013;161:229-233.
1660. Komata T, Soderstrom L, Borres MP, Tachimoto H, Ebisawa M. Usefulness of wheat and soybean specific IgE antibody titers for the diagnosis of food allergy. *Allergol Int*. 2009;58:599-603.
1661. Mattsson L, Valcour A, Holmqvist M, Larsson H, Lidholm J. Cyclophilin - A novel cross-reactive determinant in peanut. *Clin Exp Allergy*. 2021;51:620-622.
1662. Martin PE, Eckert JK, Koplin JJ, et al. Which infants with eczema are at risk of food allergy? Results from a population-based cohort. *Clin Exp Allergy*. 2015;45:255-264.
1663. Niggemann B, Schmitz R, Schlaud M. The high prevalence of peanut sensitization in childhood is due to cross-reactivity to pollen. *Allergy*. 2011;66:980-981.
1664. Codreanu F, Collignon O, Roitel O, et al. A novel immunoassay using recombinant allergens simplifies peanut allergy diagnosis. *Int Arch Allergy Immunol*. 2011;154:216-226.
1665. Krause S, Reese G, Randow S, et al. Lipid transfer protein (Ara h 9) as a new peanut allergen relevant for a Mediterranean allergic population. *J Allergy Clin Immunol*. 2009;124:771-778.e775.
1666. Nilsson C, Berthold M, Mascialino B, Orme ME, Sjolander S, Hamilton RG. Accuracy of component-resolved diagnostics in peanut allergy: Systematic literature review and meta-analysis. *Pediatr Allergy Immunol*. 2020;31:303-314.
1667. Spitzauer S, Pandjaitan B, Söregi G, et al. IgE cross-reactivities against albumins in patients allergic to animals. *J Allergy Clin Immunol*. 1995;96(6 Pt 1):951-959. doi:10.1016/s0091-6749(95)70233-4
1668. Voltolini S, Spigno F, Cioè A, et al. Bovine serum albumin: a double allergy risk. *Eur Ann Allergy Clin Immunol*. 2013;45(4):144-147.
1669. Hilger C, Swiontek K, Hentges F, et al. Occupational inhalant allergy to pork followed by food allergy to pork and chicken: sensitization to hemoglobin and serum albumin. *Int Arch Allergy Immunol*. 2010;151(2):173-178. doi:10.1159/000236008
1670. Cheikh Rouhou S, Bachouch I, Racil H, et al. Choc anaphylactique à la viande de poulet [Anaphylaxis due to chicken meat]. *Rev Mal Respir*. 2012;29(1):98-100. doi:10.1016/j.rmr.2011.11.009
1671. Ashkenazy H, Abadi S, Martz E, et al. ConSurf 2016: an improved methodology to estimate and visualize evolutionary conservation in macromolecules. *Nucleic Acids Res*. 2016;44(W1):W344-W350. doi:10.1093/nar/gkw408
1672. Salo PM, Sever ML, Zeldin DC. Indoor allergens in school and day care environments. *J Allergy Clin Immunol*. 2009;124(2):185-194. doi:10.1016/j.jaci.2009.05.012
1673. Ballardini N, Nopp A, Hamsten C, et al. Anaphylactic reactions to novel foods: case report of a child with severe crocodile meat allergy. *Pediatrics*. 2017;139(4):e20161404. doi:10.1542/peds.2016-1404
1674. Crespo JF, Retzek M, Foetisch K, et al. Germin-like protein Cit s 1 and profilin Cit s 2 are major allergens in orange (*Citrus sinensis*) fruits. *Mol Nutr Food Res*. 2006;50:282-290.
1675. Mahesh PA, et al. Prevalence of food sensitization and probable food allergy among adults in India: the EuroPrevall INCO study. *Allergy*. 2016;71(7):1010-1019.
1676. Yu HL, Cao MJ, Cai QF, et al. Effects of different processing methods on digestibility of *Scylla paramamosain* allergen (tropomyosin). *Food Chem Toxicol*. 2011;49(4):791-798.
1677. Ayuso R, Grishina G, Ibáñez MD, et al. Sarcoplasmic calcium-binding protein is an EF-hand-type protein identified as a new shrimp allergen. *J Allergy Clin Immunol*. 2009;124(1):114-120.
1678. Ayuso R, Lehrer SB, Reese G. Identification of continuous, allergenic regions of the major shrimp allergen Pen a 1 (tropomyosin). *Int Arch Allergy Immunol*. 2002;127(1):27-37.
1679. Bauermeister K, Wangorsch A, Garoffo LP, et al. Generation of a comprehensive panel of crustacean allergens from the North Sea Shrimp Crangon crangon. *Mol Immunol*. 2011;48(15-16):1983-1992.
1680. Akimoto S, Yokooji T, Ogino R, et al. Identification of allergens for food-dependent exercise-induced anaphylaxis to shrimp. *Sci Rep*. 2021;11(1):5400.
1681. Arzt L, Bokanovic D, Schrautzer C, et al. Questionable diagnostic benefit of the commercially available panel of bee venom components. *Allergy*. 2017;72(9):1419-1422.
1682. Frick M, Müller S, Bantleon F, et al. rApi m 3 and rApi m 10 improve detection of honey bee sensitization in Hymenoptera venom-allergic patients with double sensitization to honey bee and yellow jacket venom. *Allergy*. 2015;70(12):1665-1668.
1683. Hofmann SC, Pfender N, Weckesser S, et al. Reply: to PMID 21439627. *J Allergy Clin Immunol*. 2011;128(1):248.

1684. Jakob T, Köhler J, Blank S, et al. Comparable IgE reactivity to natural and recombinant Api m 1 in cross-reactive carbohydrate determinant-negative patients with bee venom allergy. *J Allergy Clin Immunol*. 2012;130(1):276-279.
1685. Korošec P, Valenta R, Mittermann I, et al. Low sensitivity of commercially available rApi m 1 for diagnosis of honeybee venom allergy. *J Allergy Clin Immunol*. 2011;128(3):671-673.
1686. Müller U, Schmid-Grendelmeier P, Hausmann O, et al. IgE to recombinant allergens Api m 1, Ves v 1, and Ves v 5 distinguish double sensitisation from crossreaction in venom allergy. *Allergy*. 2012;67(8):1069-1073.
1687. Müller UR, Johansen N, Petersen AB, et al. Hymenoptera venom allergy: analysis of double positivity to honey bee and *Vespa* venom by estimation of IgE antibodies to species-specific major allergens Api m1 and Ves v5. *Allergy*. 2009;64(4):543-548.
1688. Sturm GJ, Hemmer W, Hawranek T, et al. Detection of IgE to recombinant Api m 1 and rVes v 5 is valuable but not sufficient to distinguish bee from wasp venom allergy. *J Allergy Clin Immunol*. 2011;128(1):247-248.
1689. Vachová M, Panzner P, Kopač P, et al. Routine clinical utility of honeybee venom allergen components. *J Allergy Clin Immunol Pract*. 2018;6(6):2121-2123.e1.
1690. Blank S, Haemmerle S, Jaeger T, et al. Prevalence of Hymenoptera venom allergy and sensitisation in the population-representative German KORA cohort. *Allergo J Int*. 2019;28(6):183-191.
1691. Hoffman DR, Sakell RH, Schmidt M. Sol i 1, the phospholipase allergen of imported fire ant venom. *J Allergy Clin Immunol*. 2005;115(3):611-616.
1692. Perez-Riverol A, Palma MS, Jakob T. Current challenges in diagnostics of insect venom allergy. *Allergo J Int*. 2020;29:79-91.
1693. Raulf M, Rihs HP. Latex allergens: source of sensitisation and single allergens. In: Kleine-Tebbe J, Jakob T, eds. *Molecular Allergy Diagnostics - Innovation for a Better Patient Management*. Springer International Publishing; 2017:459-470.
1694. Manavski N, Peters U, Brettschneider R, et al. Cof a 1: identification, expression and immunoreactivity of the first coffee allergen. *Int Arch Allergy Immunol*. 2012;159(3):235-242.
1695. Sander I, Raulf M. Industrial enzymes as cause for occupational airway allergies - a review. *Allergologie*. 2018;41:511-528.
1696. Allergome. <http://www.allergome.com/>. Accessed September 4, 2021.
1697. Mari A. Skin test with a timothy grass (*Phleum pratense*) pollen extract vs. IgE to a timothy extract vs. IgE to rPhl p 1, rPhl p 2, nPhl p 4, rPhl p 5, rPhl p 6, rPhl p 7, rPhl p 11, and rPhl p 12: epidemiological and diagnostic data. *Clin Exp Allergy*. 2003;33(1):43-51.
1698. Diaz-Perales A, Escribese MM, Garrido Arandia M, et al. The role of spingolipids in allergic sensitisation and inflammation. *Front Allergy*. 2021;2:675557.
1699. Pastorello EA, Ortolani C, Farioli L, et al. Allergenic cross-reactivity among peach, apricot, plum, and cherry in patients with oral allergy syndrome: an in vivo and in vitro study. *J Allergy Clin Immunol*. 1994;94(4):699-707.
1700. Alevizos M, Karagkouni A, Kontou-Fili K, et al. A probable case report of stress-induced anaphylaxis. *Ann Allergy Asthma Immunol*. 2014;112(4):383-384.
1701. PALISADE Group of Clinical investigators. AR101 oral immunotherapy for Peanut allergy. *N Engl J Med*. 2018;379(21):1991-2001.
1702. Skripak JM, Nash SD, Rowley H, et al. A randomized double blind placebo -controlled study of milk oral immunotherapy for cow milk allergy. *J Allergy Clin Immunol*. 2008;122(6):1154-1160.
1703. Bonertz A, Mahler V, Vieths S. New Guidance on the regulation of allergen products: key aspects and outcomes. *Curr Opin Allergy Clin Immunol*. 2020;20(6):624-630.
1704. Lerouge P, Cabanes-Macheteu M, Rayon C, et al. N-Glycoprotein biosynthesis in plants: recent developments and future trends. *Plant Mol Bio*. 1998;38:31-48.
1705. Liu Z, Xia L. Identification and characterization of an arginine kinase as major allergen from silkworm larvae. *Int Arch Allergy Immunol*. 2009;150(1):8-14.
1706. Jeong KY, Han IS, Lee JY, Park KH, Lee JH, Park JW. Role of tropomyosin in silkworm allergy. *Mol Med Rep*. 2017;15(5):3264-3270.
1707. Bublin M, Dennstedt S, Buchegger M, et al. The performance of a component-based allergen microarray for the diagnosis of kiwifruit allergy. *Clin Exp Allergy*. 2011;41(1):129-136.
1708. Gadermaier G, Egger M, Girbl T, et al. Molecular characterization of Api g 2, a novel allergenic member of the lipid-transfer protein 1 family from celery stalks. *Mol Nutr Food Res*. 2011;55(4):568-577.
1709. Nouri HR, Sankian M, Vahedi F, et al. Diagnosis of chenopodium album allergy with a cocktail of recombinant allergens as a tool for component resolved diagnosis. *Allergy*. 2011;66:530-531.
1710. Hayek B, Vangelista L, Pastore A, et al. Molecular and immunologic characterization of a highly cross-reactive two EF-hand calcium binding alder pollen allergen Aln g 4: structural basis for calcium-modulated IgE recognition. *J Immunol*. 1998;161(1):7031-7039.
1711. Mas S, Garrido-Arandia M, Batanero E, et al. Characterization of profilin and polcalcin panallergens from ash pollen. *J Invest Allergol Clin Immunol*. 2014;24:257-266.
1712. Pico de Coaña Y, Parody N, Fuertes MÁ. Molecular cloning and characterization of Cup a 4, a new allergen from *Cupressus arizonia*. *Biochem Biophys Res Commun*. 2010;401(3):451-457.
1713. Li J, Sun B, Huang Y, et al. A multicentre study assessing the prevalence of sensitisations in patients with asthma and/or rhinitis in China. *Allergy*. 2009;64(7):1083-1092.
1714. Morakabati P, Assarehzadegan MA, Khosravi GR, et al. Cloning and expression of Ama r 1, as a novel allergen of *Amaranthus retroflexus* pollen. *J Allergy (Cairo)*. 2016;2016:4092817.

How to cite this article: Dramburg S, Hilger C, Santos A, et al. EAACI Molecular Allergy User's Guide 2.0. *Pediatr Allergy Immunol*. 2023;34:e13854. doi:[10.1111/pai.13854](https://doi.org/10.1111/pai.13854)